



Designation: **D 3398 – 9700**

## Standard Test Method for Index of Aggregate Particle Shape and Texture<sup>1</sup>

This standard is issued under the fixed designation D 3398; the number immediately following the designation indicates the year of original adoption or, in the case of revision, the year of last revision. A number in parentheses indicates the year of last reapproval. A superscript epsilon ( $\epsilon$ ) indicates an editorial change since the last revision or reapproval.

### 1. Scope\*

1.1 This test method covers the determination of the particle index of aggregate as an overall measure of particle shape and texture characteristics.

1.2 The values stated in inch-pound units are to be regarded as the standard. The SI units given in parentheses may be approximate, except with regard to sieve size and size of aggregate, the standard SI designations shown in parentheses are the standard as stated in Specification E 11.

1.3 *This standard does not purport to address all of the safety concerns, if any, associated with its use. It is the responsibility of the user of this standard to establish appropriate safety and health practices and determine the applicability of regulatory limitations prior to use.*

### 2. Referenced Documents

#### 2.1 ASTM Standards:

---

<sup>1</sup> This test method is under the jurisdiction of ASTM Committee ~~D-4~~ D04 on Roads and Paving Materials and is the direct responsibility of Subcommittee D04.51 on Aggregate Tests.

Current edition approved July 10, ~~1997~~, 2000. Published ~~April 1998~~, September 2000. Originally published as D 3398 – 75. Last previous edition D 3398 – ~~937~~.

\*A Summary of Changes section appears at the end of this standard.

- C 127 Test Method for Specific Gravity and Absorption of Coarse Aggregate<sup>2</sup>
- C 128 Test Method for Specific Gravity and Absorption of Fine Aggregate<sup>2</sup>
- C 136 Test Method for Sieve Analysis of Fine and Coarse Aggregates<sup>2</sup>
- C 702 Practice for Reducing Field Samples of Aggregate to Testing Size<sup>2</sup>
- D 75 Practice for Sampling Aggregates<sup>3</sup>
- D 1883 Test Method for Bearing Ratio of Laboratory-Compacted Soils<sup>4</sup>
- D 3665 Practice for Random Sampling of Construction Materials<sup>3</sup>
- D 4753 Specification for Evaluating, Selecting, and Specifying Balances and Scales for Use in Testing Soil, Rock, and Related Construction Materials<sup>4</sup>
- E 11 Specification for Wire-Cloth and Sieves for Testing Purposes<sup>5</sup>

### 3. Significance and Use

3.1 This test method provides an index value to the relative particle shape and texture characteristics of aggregates. This value is a quantitative measure of the aggregate shape and texture characteristics that may affect the performance of road and paving mixtures. This test method has been successfully used to indicate the effects of these characteristics on the compaction and strength characteristics of soil-aggregate and asphalt concrete mixtures.<sup>6,7,8,9</sup>

### 4. Apparatus

4.1 *Cylindrical Molds*—Cylindrical molds for determining voids in aggregate, in accordance with the procedure described in this test method, shall be machined to accurate dimensions on the inside, and sufficiently rigid to retain their forms under rough usage. The dimensions of the molds shall conform to the limits in Table 1.

4.2 *Tamping Rods*—Round, straight, steel tamping rods, having the tamping end rounded to a hemispherical tip, shall be enclosed in a loose-fitting steel sleeve as shown in Fig. 1, to control the height of drop to exactly 2 in. (50 mm). The dimensions and mass of the tamping rods shall conform to the limits in Table 2.

4.3 *Balance*—A balance having a minimum capacity of 15 kg and meeting the requirements of Specification D 4753, Class GP5.

### 5. Sampling

5.1 Sample the aggregate to be tested in accordance with Practices D 75 and D 3665, and reduce to the appropriate test sample size in accordance with Practice C 702.

<sup>2</sup> Annual Book of ASTM Standards, Vol 04.02.

<sup>3</sup> Annual Book of ASTM Standards, Vol 04.03.

<sup>4</sup> Annual Book of ASTM Standards, Vol 04.08.

<sup>5</sup> Annual Book of ASTM Standards, Vol 14.02.

<sup>6</sup> Huang, E. Y., "A Test for Evaluating the Geometric Characteristics of Coarse Aggregate Particles," *ASTM Proceedings*, Vol 62, 1962, pp. 1223–1242.

<sup>7</sup> Huang, E. Y., Auer, A., and Triffo, R. P., "Effect of Geometric Characteristics of Coarse Aggregates on Strength of Soil-Aggregate Mixtures," *ASTM Proceedings*, Vol 64, 1964, pp. 922–933.

<sup>8</sup> McLeod, Norman W., and McLean, J. A., "A Laboratory Investigation of the Compaction of Dense Graded Asphalt Concrete," paper presented at the 19th Annual Conference of the Canadian Technical Asphalt Association, Regina Saskatchewan, Canada, 1974.

<sup>9</sup> McLeod, Norman W., and Davidson, J. Keith, "Particle Index Evaluation of Aggregate Paving Mixtures," *Proceedings*, Association of Asphalt Paving Technologies, Vol 50, 1981, pp. 251–290.

**TABLE 1 Dimensions of Cylindrical Molds**

Mold Designation <sup>A,B</sup>	Inside Diameter, in. (mm)	Inside Height, in. (mm)	Min Thickness of Metal, in. (mm)		For Testing Aggregate	
			Bottom	Wall	Passing, in. (mm)	Retained, in. (mm)
A	8.00 ± 0.01 (203.2 ± 0.2)	9.33 ± 0.01 (237.0 ± 0.2)	0.24 (6.1)	0.24 (6.1)	1½ (38.1)	1 (25.4)
B <sup>C</sup>	6.00 ± 0.01 (152.40 ± 0.2)	7.00 ± 0.01 (177.8 ± 0.2)	0.24 (6.1)	0.24 (6.1)	1 (25.4) ¾ (19.0)	¾ (19.0) ½ (12.7)
C	4.00 ± 0.01 (101.6 ± 0.1)	4.6 ± 0.01 (118.5 ± 0.2)	0.20 (5.1)	0.20 (5.1)	½ (12.7) ⅜ (9.5)	⅜ (9.5) No. 4 (4.75)
D	3.00 ± 0.01 (76.2 ± 0.2)	3.50 ± 0.01 (88.9 ± 0.2)	0.16 (4.1)	0.16 (4.1)	No. 4 (4.75) No. 8 (2.36)	No. 8 (236) No. 16 (118)
E	2.00 ± 0.01 (50.8 ± 0.2)	2.33 ± 0.01 (59.3 ± 0.2)	0.15 (3.8)	0.15 (3.8)	No. 16 (1.18) No. 30 (600 µm) No. 50 (300 µm) No. 100 (150 µm)	No. 3 (600 µm) No. 50 (300 µm) No. 100 (150 µm) No. 200 (175 µm)

<sup>A</sup>A cylindrical mold with a given designation must be used with the tamping rod having the same designation.

<sup>B</sup>A mold designated for testing a given aggregates size fraction may also be used to test any smaller size fraction.

<sup>C</sup>The mold specified in Test Method D 1883 is the same size.

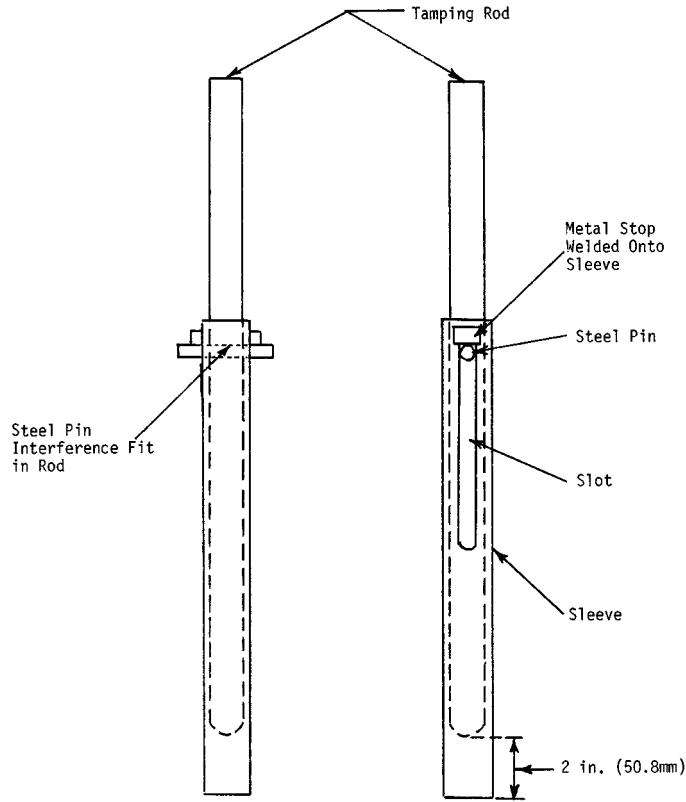

FIG. 1 Tamping Rod and Sleeve

TABLE 2 Dimensions and Mass of Tamping Rods

Rod Designation <sup>A</sup>	Diameter, in. (mm)	Length, in. (mm)	Mass, g
A	0.83 ± 0.01 (21.2 ± 0.2)	32.0 ± 0.01 (814.0 ± 0.2)	2204 ± 10
B	0.63 ± 0.1 (15.9 ± 0.2)	24.0 ± 0.01 (610.0 ± 0.2)	930 ± 10
C	0.42 ± 0.01 (10.6 ± 0.2)	16.0 ± 0.01 (406.9 ± 0.2)	276 ± 3
D	0.31 ± 0.01 (7.9 ± 0.2)	12.0 ± 0.01 (306.0 ± 0.2)	116 ± 1
E	0.21 ± 0.01 (5.3 ± 0.2)	7.9 ± 0.01 (201.7 ± 0.2)	34 ± 0.5

<sup>A</sup>A tamping rod with a given designation must be used with a mold having the same designation.

## 6. Calibration of Mold

6.1 Determine the volume of the mold in millilitres as described below at least two times, and use the average volume in the calculation of the percentage of voids in 8.2.

6.1.1 Fill the mold with water at room temperature and cover with a piece of plate glass in such a way as to eliminate bubbles and excess water.

6.1.2 Determine the mass of water in the mold to an accuracy of 4 g or less.

6.1.3 Measure the temperature of the water and determine the volume of the mold by multiplying the mass of the water by the corresponding specific volume of water given in Table 4 for the temperature involved.

## 7. Test Specimen Preparation

7.1 Obtain a sample that yields at least the mass required for the mold being used (see Table 3) for each size fraction to be tested. Test each size fraction, listed in 7.2, when present in the aggregate in amounts of 10 % or more.

7.2 Wash the sample of aggregate by decantation of the wash water through the No. 200 (75-µm) sieve or through a sieve at least one size smaller than that which is to be the lower limit of the smallest sieve-size fraction to be tested. Continue the washing and decanting operation until the wash water is clear. Then flush the residue on the sieve back into the aggregate sample. Dry the sample to constant weight at a temperature of 230 ± 9°F (110 ± 5°C) and sieve the material in accordance with Test Method C 136 into the following size fractions:

**TABLE 3 Aggregate Specimen Size for Test Using Various Molds**

Mold Designation	Aggregate Specimen Size, lb (kg)
A	30 (13.6)
B	13 ( 5.9)
C	4 ( 1.8)
D	2 ( 0.9)
E	0.6 ( 0.3)

**TABLE 4 Specific Volume of Water at Different Temperatures<sup>A</sup>**

Temperature, °F (°C)	Specific Volume, mL/g
54 (12)	1.0005
57 (14)	1.0007
61 (16)	1.0010
64 (18)	1.0014
68 (20)	1.0018
72 (22)	1.0022
75 (24)	1.0027
79 (26)	1.0032
82 (28)	1.0038
86 (30)	1.0044
90 (32)	1.0050

<sup>A</sup>Values other than those shown may be obtained from the *Handbook of Chemistry and Physics*, Chemical Rubber Publishing Co., Cleveland, Ohio.

Passing	Retained
1½ in. (37.5 mm)	1 in. (25.0 mm)
1 in. (25.0 mm)	¾ in. (19.0)
¾ in. (19.0 mm)	½ in. (12.7 mm)
½ in. (12.5 mm)	⅜ in. (9.5 mm)
⅜ in. (9.5 mm)	No. 4 (4.75 mm)
No. 4 (4.75 mm)	No. 8 (2.36 mm)
No. 8 (2.36 mm)	No. 16 (1.18 mm)
No. 16 (1.18 mm)	No. 30 (600 µm)
No. 30 (600 µm)	No. 50 (300 µm)
No. 50 (300 µm)	No. 100 (150 µm)
No. 100 (150 µm)	No. 200 (75 µm)

It is not necessary to include sieves in the sieve analysis below the smallest size which is available in an amount of more than 10 %.

7.3 After the required amount of material has been sieved for each size fraction to be tested, determine the bulk-dry specific gravity of each size fraction in accordance with Test Methods C 127 and C 128, whichever is applicable, except that when arriving at the saturated surface-dry condition for fine aggregate in Test Method C 128, hard-finished paper towels should be used to dry the particles until no more moisture is evident on the fresh towels.

NOTE 1—The standard mold procedure for the determination of the saturated surface-dry condition of fine aggregate in Test Method C 128 does not work well with these uniform size fractions. For example, rounded aggregates with small particle indexes will not retain the cone mold shape at any moisture content.

NOTE 2—Many aggregates, either from lithologic differences in the various particle size fractions or an extensive vesicular pore system that is progressively destroyed as particle size decreases, will have significant variation in bulk dry specific gravity of the different size fractions. For these aggregates, failure to determine the actual specific gravity for each size fraction (to use in the voids calculation) may cause gross errors in the particle index determination.

## 8. Determination of Voids

8.1 Using oven-dried specimens for each size fraction, run determinations of percentage of voids at each of the two levels of compaction in accordance with the procedure given in this section. First, run two tests on the specimens for each size at the compaction of 10 drops of the tamping rod per layer. Then using the same specimens for each size, fill the mold twice using 50 drops of the rod per layer as the compactive effort.

8.1.1 Place the cylindrical mold on a uniform, solid foundation. Fill the mold in three layers. Gently place the aggregate, from the lowest height possible, into the mold until it is approximately one-third full. Level the surface with the fingers, and compact the layer using 10 drops of the tamping rod evenly distributed over the surface. Apply each drop by holding the rod vertically with its rounded end 2 in. (50 mm) above the surface of the aggregate (controlled by the slot-and-pin arrangement, as shown in Fig. 1) and releasing it so that it falls freely. Place a second layer in the mold using the same procedure, filling the mold approximately two-thirds full. As before, level the surface and apply 10 drops of the rod. Fill the remaining space in the mold with a third layer and again level the surface and apply the same compactive effort, 10 drops of the rod. After the final layer has been compacted, add individual pieces of aggregate to make the surface of the aggregate mass even with the rim of the mold, with no projections above the rim. Determine the mass of the aggregate in the mold to an accuracy of at least 4 g.

8.1.2 Repeat the filling of the mold using the same specimen and compaction. Make a second determination of the mass of the aggregate in the mold as described in 8.1.1. Use the average mass of the two runs in calculating the percentage of voids at 10 drops for each size.

NOTE 3—The masses obtained in the replicate determinations should agree within approximately 0.5 %.

8.1.3 For the higher degree of compaction, follow the steps outlined in 8.1.1 and 8.1.2, except use 50 drops of the tamping rod in compacting each layer. Again average the masses from the two runs for use in computing the percentage of voids at 50 drops for each size fraction.

8.2 Calculate the percentage of voids in each size fraction of the aggregate at 10 drops per layer and at 50 drops per layer, respectively, by the following relationships:

$$V_{10} = [1 - (M_{10}/sv)] \times 100 \quad (1)$$

$$V_{50} = [1 - (M_{50}/sv)] \times 100 \quad (1)$$

$$V_{10} = [1 - (M_{10}/sv)] \times 100 \quad (2)$$

$$V_{50} = [1 - (M_{50}/sv)] \times 100 \quad (2)$$

where:

- $V_{10}$  = voids in aggregate compacted at 10 drops per layer, %,
- $V_{50}$  = voids in aggregate compacted at 50 drops per layer, %,
- $M_{10}$  = average mass of the aggregate in the mold compacted at 10 drops per layer, g,
- $M_{50}$  = average mass of the aggregate in the mold compacted at 50 drops per layer, g,
- $s$  = bulk-dry specific gravity of the aggregate size fraction, and
- $v$  = volume of the cylindrical mold, mL.

### 9. Particle Index

9.1 Determine the particle index ( $I_a$ ) for each size fraction tested by the nomograph in Fig. 2 or as follows:

$$I_a = 1.25 V_{10} - 0.25 V_{50} - 32.0 \quad (3)$$

9.2 Calculate the weighted particle index of an aggregate containing several sizes by averaging the particle index data for each size fraction, weighted on the basis of the percentage of the fractions in the original grading of the sample as received; or

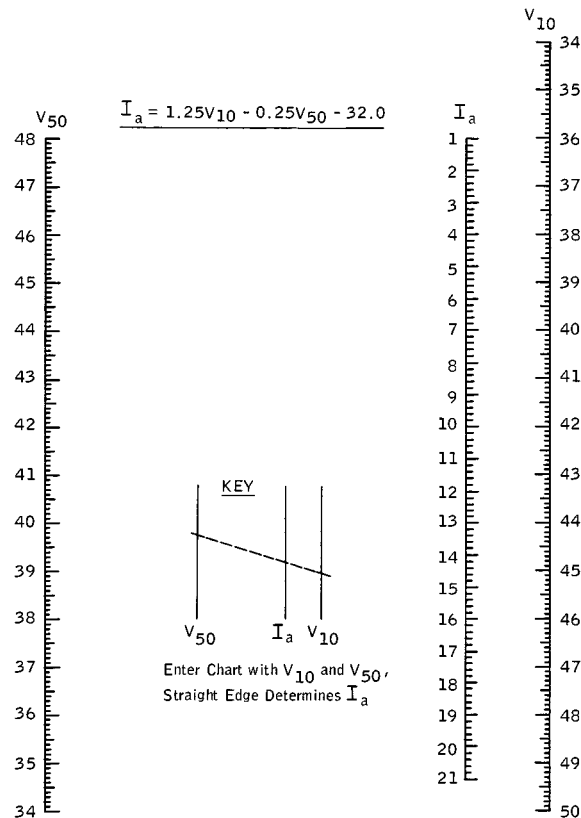

**FIG. 2 Chart for Determining Particle Index ( $I_a$ )**

preferably, on the basis of the average grading of the material proposed to be used in the work. Table 5, shown with examples of test values inserted for purposes of illustration, is a suggested form of recording and reporting the data. For sizes represented by less than 10 % in the grading, for which no particle index data were obtained, use the average particle index of the next coarser and finer sizes for which data are available or the particle index for the next coarser or finer size if a value is available only in one direction.

## 10. Precision and Bias

10.1 *Precision*—This test method is primarily used in research work and the work. A precision statement for this standard has not yet been developed at this time, therefore, this standard should not be used for acceptance or rejection of a material for purchasing purposes.

10.2 *Bias*—No information can be presented on the bias of the procedure in this test method for measuring the index of particle shape and texture, because no material having an accepted reference value is available.

## 11. Keywords

11.1 aggregate shape; aggregate texture; aggregate voids

## SUMMARY OF CHANGES

This section identifies the location of selected changes to this test method that have been incorporated since the last issue. For the convenience of the user, Committee D-4 has highlighted those changes that may impact the use of this test method. This section may also include descriptions of the changes or reasons for the changes, or both.

- (1) Note 2 was added and the existing notes renumbered, as necessary.
- (2) Section 11 was added.
- (3) Paragraph 1.3 10.1 was revised.

*ASTM International takes no position respecting the validity of any patent rights asserted in connection with any item mentioned in this standard. Users of this standard are expressly advised that determination of the validity of any such patent rights, and the risk of infringement of such rights, are entirely their own responsibility.*

*This standard is subject to revision at any time by the responsible technical committee and must be reviewed every five years and if not revised, either reapproved or withdrawn. Your comments are invited either for revision of this standard or for additional standards and should be addressed to ASTM International Headquarters. Your comments will receive careful consideration at a meeting of the responsible technical committee, which you may attend. If you feel that your comments have not received a fair hearing you should make your views known to the ASTM Committee on Standards, at the address shown below.*

*This standard is copyrighted by ASTM International, 100 Barr Harbor Drive, PO Box C700, West Conshohocken, PA 19428-2959, United States. Individual reprints (single or multiple copies) of this standard may be obtained by contacting ASTM at the above address or at 610-832-9585 (phone), 610-832-9555 (fax), or service@astm.org (e-mail); or through the ASTM website (www.astm.org).*

**TABLE 5 Example Calculation of Weighted Particle Index for an Aggregate**

Sieve Size		Aggregate Grading, %	Particle Index of each Size Group	Weighted Average (Aggregate Grading × Particle Index + 100)
Passing	Retained			
¾ in.	½ in.	3	17.2 <sup>A</sup>	0.5
½ in.	⅜ in.	42	17.2 <sup>B</sup>	7.2
⅜ in.	No. 4	36	15.8 <sup>B</sup>	5.7
No. 4	No. 8	7	15.2 <sup>C</sup>	1.1
No. 8	No. 16	10	14.6 <sup>B</sup>	1.5
No. 16	No. 30	2	14.6 <sup>A</sup>	0.3
		100		16.3

<sup>A</sup>Use particle index for next size since less than 10 %.

<sup>B</sup>Particle index measured for these sizes.

<sup>C</sup>Use average particle index for No. 8 to No. 16 and ⅜ to No. 4 sieves since quantity less than 10 %.