



Designation: D 3744 – 9703

Standard Test Method for Aggregate Durability Index¹

This standard is issued under the fixed designation D 3744; the number immediately following the designation indicates the year of original adoption or, in the case of revision, the year of last revision. A number in parentheses indicates the year of last reapproval. A superscript epsilon (ϵ) indicates an editorial change since the last revision or reapproval.

1. Scope

1.1 This test method covers the determination of a durability index of an aggregate. The calculated durability index is a value indicating the relative resistance of an aggregate to production of detrimental clay-like fines when subjected to the prescribed mechanical methods of degradation.

~~1.2 Units of Measure:~~

~~1.2.1 With regard to sieve sizes and size of aggregate as determined by the use of testing sieves, the~~

~~1.2 The values stated in inch-pound SI units are shown for the convenience of the user, but the standard sieve designation shown in parentheses is the standard value as stated in Specification E 11.~~

~~1.2.2 With regard to other units of measure, be regarded as the standard. The values shown given in parentheses are for information purposes only.~~

1.3 *This standard does not purport to address all of the safety concerns, if any, associated with its use. It is the responsibility of the user of this standard to establish appropriate safety and health practices and determine the applicability of regulatory limitations prior to use.*

2. Referenced Documents

2.1 ASTM Standards:

C 136 Test Method for Sieve Analysis of Fine and Coarse Aggregates²

¹ This test method is under the jurisdiction of ASTM Committee ~~D-4~~ D04 on Road and Paving Materials and is the direct responsibility of Subcommittee D04.51 on Aggregate Tests.

Current edition approved July 10, ~~1997~~, 2003. Published ~~February 1998~~, September 2003. Originally published as D 3744 – 79; approved in 1979. Last previous edition approved in 1997 as D 3744 – 97.

D 75 Practice for Sampling Aggregates³

D 2419 Test Method for Sand Equivalent Value of Soils and Fine Aggregate³

~~D 4753—specification 4753~~ Guide for Evaluating, Selecting, and Specifying Balances and Scales for Use in ~~Testing~~ Soil, Rock, and ~~Related Construction Materials Testing~~⁴

E 11 Specification for Wire Cloth and Sieves for Testing Purposes⁵

3. Summary of Test Method

3.1 This test method was developed to permit prequalification of aggregates proposed for use in the construction of transportation facilities. Basically, the test establishes an aggregate's resistance to generating fines when agitated in the presence of water. Separate and different test procedures are used to evaluate the coarse and the fine portions of a material.

3.2 A sample of coarse aggregate is prepared to a specific grading and then washed in a mechanical washing vessel for a 2-min agitation time. After discarding the minus ~~No. 4 (4.75-mm)~~ 4.75-mm (No. 4) material, dry the washed test sample.

3.3 The coarse aggregate test sample is then agitated in the mechanical washing vessel for a period of 10 min. A representative portion of the resulting wash water and minus ~~No. 200 (75- μ m)~~ 75- μ m (No. 200) size fines is collected and mixed with a stock calcium chloride solution and placed in a plastic cylinder. After a 20-min sedimentation time, the level of the sediment column is read. The height of the sediment value is then used to calculate the durability index of the coarse aggregate (D_c).

3.4 The fine aggregate sample is prepared by washing a specific quantity of the material in the mechanical washing vessel for a 2-min agitation period. All minus ~~No. 200 (75- μ m)~~ 75- μ m (No. 200) size material is washed from the sample through a ~~No. 200 (75- μ m)~~ 75- μ m (No. 200) sieve and discarded. The ~~plus No. 200 (75- μ m)~~ 75- μ m (No. 200) fraction is dried.

3.5 The fine aggregate test sample is tested by the Standard Sand Equivalent Test Method (Test Method D 2419) except for modifications to the test sample preparation and duration of the shaking time. The mechanical shaker method is required. A shaking time of 10 min instead of 45 s is used.

3.6 This test method includes procedures for testing aggregates exhibiting a wide range in specific gravity, including lightweight and porous coarse aggregates, and also procedures for testing small maximum size aggregate which is too fine to test as a coarse aggregate and too coarse to consider as a fine aggregate, such as a pea gravel or a very coarse sand.

3.7 The durability index for coarse aggregate (D_c) or for fine aggregate (D_f) is calculated, as applicable, by appropriate equations presented in the method. The durability index of a well-graded aggregate containing both coarse and fine fractions is defined as the lowest of the two values, D_c or D_f , obtained by the test. This value ~~should~~ is recommended to be the controlling value for specification purposes.

4. Significance and Use

4.1 This test method assigns an empirical value to the relative amount, fineness, and character of clay-like material that may be generated in an aggregate when subjected to mechanical degradation.

4.2 The procedure has been used in limited geographical areas of the United States and the results have been correlated with aggregate performance in various construction applications, including: aggregate base, permeable material for backfill, fine concrete aggregate, and riprap for rock slope protection.^{6,7}

4.3 A minimum durability index ~~may is permitted to be~~ specified to prohibit the use of an aggregate in various construction applications that is prone to degradation, resulting in generation of clay-like fines.

4.4 This test method provides a rapid test for evaluation of the quality of a new aggregate source. Research has indicated it may also be suitable for use instead of the sodium sulfate soundness test for evaluating the durability characteristics of fine aggregate for use in portland-cement concrete, thereby reducing the need for time-consuming and expensive soundness tests.⁶

4.5 Although the application of this method has been limited to aggregates for specific construction uses, the possibility exists for expanding the application of this method to control the quality of aggregates used in other areas of construction, such as aggregates for use in bituminous paving mixtures, coarse aggregate for use in portland-cement concrete, and aggregate for use as railroad ballast.

5. Apparatus

5.1 *Mechanical Washing Vessel (Pot)* —A flat-bottomed, straight-sided cylindrical vessel conforming to the specifications and dimensions shown in Fig. 1.

² Annual Book of ASTM Standards, Vol 04.02.

³ Annual Book of ASTM Standards, Vol 04.03.

⁴ Annual Book of ASTM Standards, Vol 14.02: 04.08.

⁵ Hamilton, R. D., Smith, R. E., and Sherman, G. B., "Factors Influencing the Durability

⁵ Annual Book of Aggregates," Research Report 633476, State of California, Division of Highways, Materials and Research Department, June 1971. ASTM Standards, Vol 14.02.

⁶ Hveem, F. N., and

⁶ Hamilton, R. D., Smith, R. E., and Sherman, G. B., "Factors Influencing the Durability of Aggregates," Research Report 633476, State of California, Division of Highways, Materials and Research Department, January 1964; June 1971.

⁷ Hveem, F. N., and Smith, T. N., "Durability of Aggregates," Research Report, State of California, Division of Highways, Materials and Research Department, January 1964.

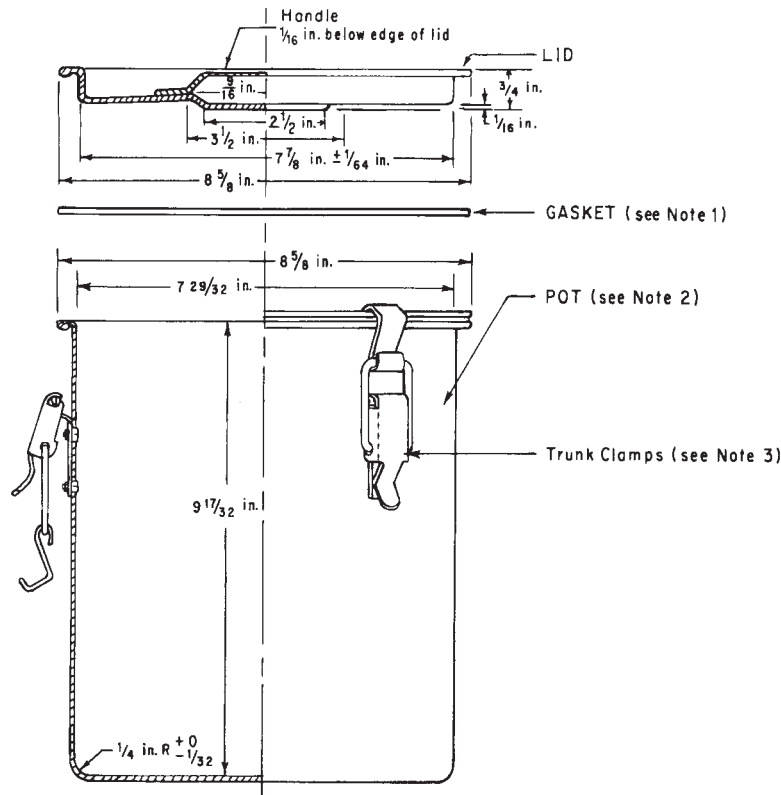

SI Equivalent

in.	mm	in.	mm	in.	mm
9 ¹⁷ / ₃₂	242.1	7 ⁷ / ₈	193.7	1/4	6.4
8 ⁵ / ₈	219.1	3 ¹ / ₂	88.9	1/16	1.6
8 ³³ / ₆₄	216.3	2 ¹ / ₂	64.8	1/32	0.79
7 ²⁹ / ₃₂	200.8	3/4	19.0	1/64	0.40
7 ²⁷ / ₃₂	199.2				

NOTE 1—The gasket shall be 1/8 in. neoprene rubber, having an inside diameter of 7 27/32 ± 1/64 in. and an outside diameter of 8 33/64 ± 1/64 in.

NOTE 2—The pot shall be a flat bottom, straight-sided, cylindrical vessel with a capacity of approximately 2 gal. The top edge shall be flared outward to form a seat for the gasket and lid.

NOTE 3—Three trunk clamps are required and shall be placed at one-third intervals. The clamps shall be attached to the pot by rivets or welds so that the pot remains watertight. When fitted with the 1/8-in. gasket and clamped in place, the lid shall form a watertight seal with the flared edge of the pot.

NOTE 4—The vessel shall be 20-gage stainless steel, unless otherwise noted. All dimensions shall be within ±1/32 in., unless otherwise noted.

FIG. 1 Mechanical Washing Vessel

5.2 *Collection Pan*—A round pan (at least 9 in. (229 mm) 230 mm (9 in.) in diameter and approximately 4 in. (102 mm) 100 mm (4 in.) deep), suitable to collect the wash water from the washed sample. The pan shall have vertical or nearly vertical sides and shall be equipped as necessary to hold the wire mesh of an 8-in. (203-mm) 203-mm (8-in.) diameter sieve at least 3 in. (76.2 mm) 75 mm (3 in.) above the bottom. An adaptor that will not allow loss of fines or wash water may be used to nest the sieve with the container, or the sieve may be nested with a blank sieve frame resting in the bottom of the pan.

5.3 *Agitator*—A mechanical device designed to hold the wash vessel in an upright position while subjecting it to a lateral reciprocating motion at a rate of 285 ± 10 complete cycles per minute. The reciprocating motion shall be produced by means of an eccentric in the base of the carrier and the length of the stroke shall be 1.75 44.5 ± 0.025 in. (44.5 ± 0.6 mm) (1.75 ± 0.025 in.). The clearance between the cam and follower of the eccentric shall be 0.001 0.25 to 0.004 in. (0.25 to 1.02 mm) (0.001 to 0.004 in.). Fig. 2 shows a Tyler portable sieve shaker modified to meet these requirements.

5.4 All equipment required to perform the Test for Sand Equivalent Value of Soils and Fine Aggregate (Test Method D 2419).

5.5 *Sieves*—The sieves shall conform to Specification E 11.

5.6 *Balance*—A balance having a minimum capacity of 500 g and meeting the requirements of Specification Guide D 4753, Class GP5.

6. Reagents and Materials

6.1 *Calcium Chloride Solutions* —Use stock and working calcium chloride solutions as specified in the Reagents and Materials section of Test Method D 2419.

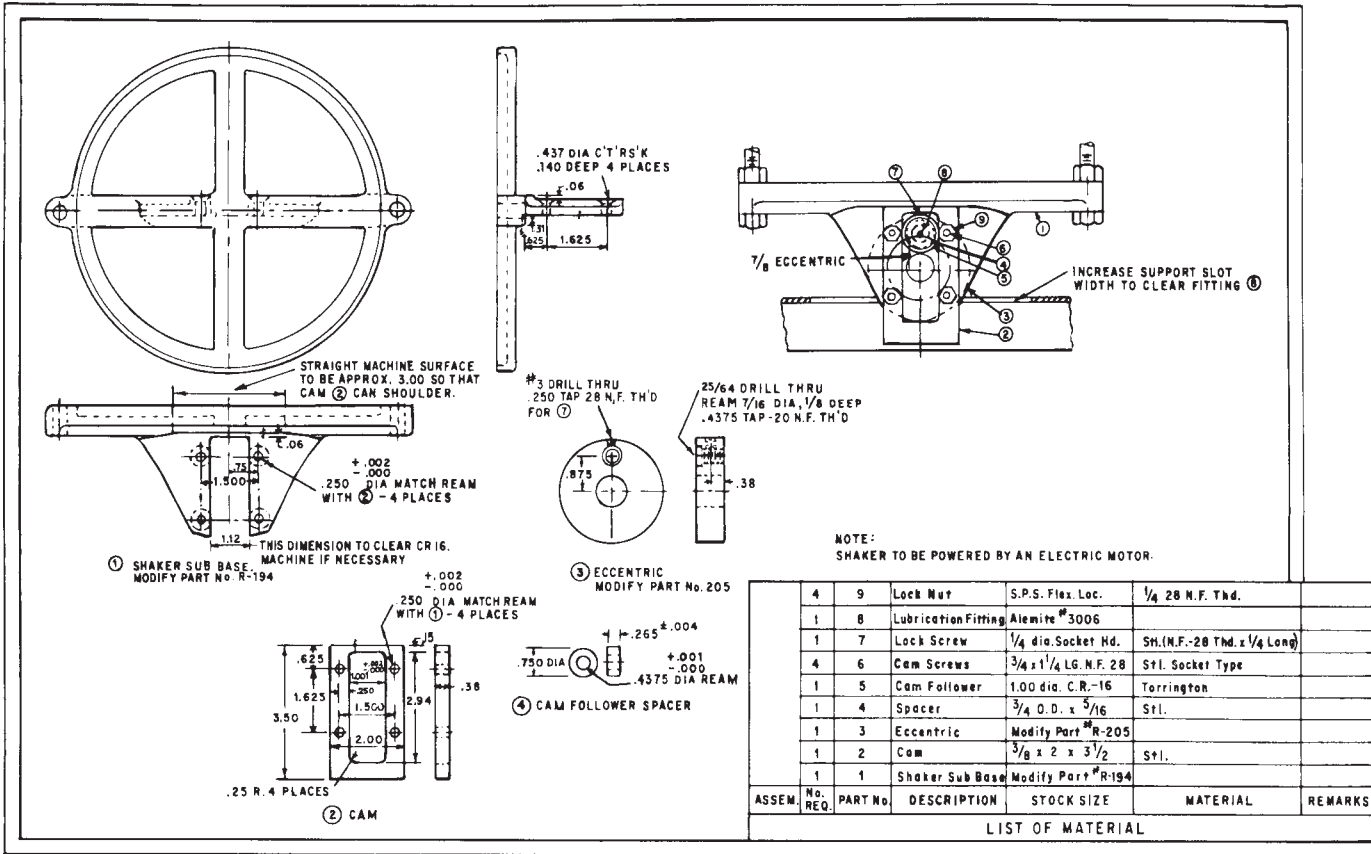

FIG. 2 Modification of Tyler Portable Sieve Shaker

6.2 ~~Water~~—Use distilled or demineralized water will be needed for the normal performance of this test method. ~~This is necessary because the~~ The test results may are likely to be affected by certain minerals dissolved in water. However, if it is determined that local tap water is of such purity that it does not affect the test results, it is permissible to use it except when otherwise specified in the procedure use of tap water is permissible in place of distilled or demineralized water. For referee purposes, distilled or demineralized water shall be used for all steps in the test.

7. Temperature Control

7.1 This test may be method is normally performed without strict temperature control; however, for referee purposes, retest the material with the temperature of the distilled or demineralized water and the working calcium chloride solution at ~~72~~ $22 \pm 5^\circ\text{F}$ ($22 \pm 3^\circ\text{C}$ ($72 \pm 3^\circ\text{C}$), 5°F).

8. Sampling

8.1 Obtain samples of the aggregate to be tested in accordance with Practice D 75.

9. Initial Sample Preparation

9.1 Dry aggregate samples sufficiently to permit a complete separation on the No. 4 (4.75-mm) 4.75-mm (No. 4) sieve and to develop a free-flowing condition in the portion passing the sieve. ~~Drying may be performed~~ Perform drying by any means method that does not heat the aggregate in excess of 140°F (60°C) 60°C (140°F) or cause degradation of the particles. The use of sunlight, ovens, or forced drafts of warm air are the most common drying methods.

9.2 If the sample contains an appreciable amount of clay, turn the aggregate frequently during the drying process to obtain even drying throughout and prevent the formation of hard clay lumps.

9.3 Break up any hard clods and remove coatings of fines from the coarse aggregate particles by any means that will not appreciably reduce the natural individual particle sizes.

9.4 Determine the sample grading by sieving in accordance with Test Method C 136 on the 19.0, 12.5, 9.5, 4.75, 2.36, and 1.18-mm ($3/4$, $1/2$, $3/8$ -in. and Nos. 4, 8, and 16 (19.0, 12.5, 9.5, 4.75, 2.36, and 1.18-mm) 16) sieves. Discard any material that is retained on the $3/4$ -in. (19.0-mm) 19.0-mm ($3/4$ -in.) sieve.

9.5 Determine the test procedures to be used for establishing the durability index of the aggregate based upon the grading of the aggregate as determined in 9.4.

9.5.1 If less than 10 % of the aggregate passes the ~~No. 4 (4.75-mm)~~ 4.75-mm (No. 4) sieve, test coarse aggregate (Procedure A) only.

9.5.2 If less than 10 % of the aggregate is coarser than the ~~No. 4 (4.75-mm)~~ 4.75-mm (No. 4) sieve, test fine aggregate (Procedure B) only.

9.5.3 When both coarse and fine aggregate fractions are each present in quantities equal to or greater than 10 % and if the percent passing the ~~No. 16 (1.18-mm)~~ 1.18-mm (No. 16) sieve is greater than 10 %, use both Procedures A and B on the appropriate aggregate sizes. If the percent passing the ~~No. 16 (1.18-mm)~~ 1.18-mm (No. 16) sieve is less than or equal to 10 %, use Procedure A or Procedure C.

9.5.4 If most of the aggregate (75 to 80 %) is retained between the 9.5 and 1.18-mm (3/8-in. and No. 16 (9.5 and 1.18-mm) 16) sieves, use Procedure C only.

PROCEDURE A—COARSE AGGREGATE

10. Test Sample Preparation

10.1 Prepare a 2550 ± 25 -g (air-dry) preliminary test sample using the grading given below:

Aggregate Size	Air Dry Mass, g
3/4 to 1/2 in. (19.0 to 12.5 mm)	1070 ± 10
<u>19.0 to 12.5 mm (3/4 to 1/2 in.)</u>	<u>1070 ± 10</u>
1/2 to 3/8 in. (12.5 to 9.5 mm)	570 ± 10
<u>12.5 to 9.5 mm (1/2 to 3/8 in.)</u>	<u>570 ± 10</u>
3/8 in. to No. 4 (9.5 to 4.75 mm)	910 ± 5
<u>9.5 to 4.75 mm (3/8 in. to No. 4)</u>	<u>910 ± 5</u>
	<u>2550 ± 25</u>

For materials with less than 10 % in any of the size fractions given in 10.1, prepare the test sample using the actual percentage for the deficient fraction and proportionally increase the mass of the remaining fractions to obtain the 2550 g test sample. Two examples follow.

Example 1—Less than 10 % in ~~3/4 to 1/2 in. (19.0 to 12.5 mm)~~ fraction
 Example 1—Less than 10 % in 19.0 to 12.5 mm (3/4 to 1/2 in.) fraction

Aggregate Size	Percent	Calculation	Air Dry Mass, g
3/4 to 1/2 in. (19.0 to 12.5 mm)	6	0.06 × 2550	153 ± 10
<u>19.0 to 12.5 mm (3/4 to 1/2 in.)</u>	<u>6</u>	<u>0.06 × 2550</u>	<u>153 ± 10</u>
1/2 to 3/8 in. (12.5 to 9.5 mm)	26	570 (2550 - 153)	923 ± 10
<u>12.5 to 9.5 mm (1/2 to 3/8 in.)</u>	<u>26</u>	<u>570 (2550 - 153)</u>	<u>923 ± 10</u>
3/8 to No. 4 (9.5 to 4.75 mm)	68	910 (2550 - 153)	1474 ± 5
<u>9.5 to 4.75 mm (3/8 to No. 4)</u>	<u>68</u>	<u>910 (2550 - 153)</u>	<u>1474 ± 5</u>
Totals	100		2550 ± 25

Example 2—Less than 10 % in two fractions

Aggregate Size	Percent	Calculation	Air Dry Mass, g
3/4 to 1/2 in. (19.0 to 12.5 mm)	4	0.04 × 2550	102 ± 10
<u>19.0 to 12.5 mm (3/4 to 1/2 in.)</u>	<u>4</u>	<u>0.04 × 2550</u>	<u>102 ± 10</u>
1/2 to 3/8 in. (12.5 to 9.5 mm)	7	0.07 × 2550	179 ± 10
<u>12.5 to 9.5 mm (1/2 to 3/8 in.)</u>	<u>7</u>	<u>0.07 × 2550</u>	<u>179 ± 10</u>
3/8 to No. 4 (9.5 to 4.75 mm)	89	2550 - (102 + 179)	2269 ± 5
<u>9.5 to 4.75 mm (3/8 to No. 4)</u>	<u>89</u>	<u>2550 - (102 + 179)</u>	<u>2269 ± 5</u>
Totals	100		2550 ± 25

10.2 Place the preliminary test sample in the mechanical washing vessel, and add 1000 ± 5 ml of distilled or demineralized water, clamp the vessel lid in place, and secure the vessel in the sieve shaker.

10.3 Because of the low specific gravity or high absorption rate, or both, of some aggregates, the proportions of aggregate to water may will not permit provide the intended interparticle abrasion. Testing of these materials will require adjustment of the test specimen mass or volume of both wash and test water, or both.

10.3.1 Wash all materials that are not completely inundated when 1000 ml of water are added to the test sample and test with adjusted sample masses and water volumes.

10.3.2 Determine the bulk, oven-dry specific gravity, and percentage of absorption of the aggregate in accordance with Test Method C 127.

10.3.3 Adjust the total mass of the test sample using the following equation:

$$A \text{ djusted sample mass, g} = \frac{\text{specific gravity of aggregate}}{2.65} \times W \quad (1)$$

$$\text{Adjusted sample mass, g} = \frac{\text{specific gravity of aggregate}}{2.65} \times W \quad (1)$$

where:

W = mass of oven-dried test sample, g.

Adjust the mass of material in each size fraction proportionally to the masses specified in 10.1.

10.3.4 Adjust the volume of test water using the following equation:

$$\text{Adjusted water} = 1000 + (A \times W) - 50 \quad (2)$$

$$\text{Adjusted water} = 1000 + (A \times W) - 50 \quad (2)$$

where:

A = absorption of aggregate, % (expressed as a decimal fraction), and

W = mass of oven-dried test sample, g.

10.4 Clamp the vessel lid in place, and secure the vessel in the sieve shaker. Begin agitation after a time of 60 ± 10 s has elapsed from the introduction of the wash water. Agitate the vessel in the sieve shaker for 120 ± 5 s.

10.5 After the 2-min agitation time is completed, remove the vessel from the shaker, unclamp the lid and pour the contents onto a ~~No. 4 (4.75-mm)~~ 4.75-mm (No. 4) sieve. Rinse any remaining fines from the vessel onto the sieve and direct water (from a flexible hose attached to a faucet) onto the aggregate until the water passing through the sieve comes out clear.

10.6 Dry the fraction retained on the ~~No. 4 (4.75-mm)~~ 4.75-mm (No. 4) sieve to constant mass at a temperature of ~~230 \pm 9°F (110 \pm 5°C)~~ 230 \pm 5°C (430 \pm 9°F) and weigh. If the loss in mass due to washing in accordance with 10.2, 10.3, 10.4, and 10.5 is equal to or less than 75 g, a test sample suitable for further testing has been prepared and the procedures in 10.7-10.12 ~~should be are~~ omitted. If the loss in mass exceeds 75 g, the preliminary test sample ~~can~~ is permitted to be retained and used if a second sample is washed by the same procedure and the two samples are combined according to the specified masses to provide the desired test sample.

10.7 Determine the grading to be used in preparing the preliminary test sample as follows:

10.7.1 If each of the aggregate sizes listed in the following table represents 10 % or more of the 19.0-mm to 4.75-mm ($\frac{3}{4}$ -in. to No. 4 (19.0-mm to 4.75-mm) 4) portion, as determined from the masses recorded in 9.4, use the oven-dry masses of material specified below for preparing the preliminary test sample.

Aggregate Size	Oven-Dry Mass, g
$\frac{3}{4}$ to $\frac{1}{2}$ in. (19.0 to 12.5 mm)	1050 \pm 10
19.0 to 12.5 mm ($\frac{3}{4}$ to $\frac{1}{2}$ in.)	1050 \pm 10
$\frac{1}{2}$ to $\frac{3}{8}$ in. (12.5 to 9.5 mm)	550 \pm 10
12.5 to 9.5 mm ($\frac{1}{2}$ to $\frac{3}{8}$ in.)	550 \pm 10
$\frac{3}{8}$ in. to No. 4 (9.5 to 4.75 mm)	900 \pm 5
9.5 to 4.75 mm ($\frac{3}{8}$ in. to No. 4)	900 \pm 5
	2500 \pm 25

10.8 Prepare a 2500-g preliminary test sample using the prescribed grading. Dry the test sample to constant mass at a temperature of ~~230 \pm 9°F (110 \pm 5°C)~~ 230 \pm 5°C (430 \pm 9°F).

10.9 Mechanically wash the preliminary sample in the same manner as prescribed in 10.2, 10.3, 10.4, and 10.5.

10.10 Repeat 10.8 and 10.9, if necessary, to obtain sufficient material to yield a washed test sample of 2500 ± 25 g and contain each size fraction in the quantity specified in 10.7.1.

10.11 After allowing the oven-dried material to cool, separate the washed coarse aggregate on the 12.5, 9.5, and 4.75-mm ($\frac{1}{2}$, $\frac{3}{8}$ -in., and No. 4 (12.5, 9.5, and 4.75-mm) 4) sieves. Discard the material passing the ~~No. 4 (4.75-mm)~~ 4.75-mm (No. 4) sieve.

10.12 Prepare the washed test sample using the masses specified in 10.7.1 from representative portions of each size of washed material. Occasionally ~~it may be necessary to wash~~ a third preliminary test sample is needed to obtain the required mass of material of a specific size.

11. Procedure for Coarse Aggregate

11.1 Place the plastic cylinder (sand equivalent test cylinder as required in Test Method D 2419) on a work table which will not be subjected to vibrations during the performance of the sedimentation phase of the test. ~~Pour 0.24 oz (7 ml) 7 ml (0.24 oz)~~ of the stock calcium chloride solution into the cylinder. Place a 4.75-mm and 75 μ m (Nos. 4 and 200 (4.75-mm and 75- μ m) 200) sieve on the pan or vessel provided to collect the wash water with the 4.75 mm (No. 4) sieve on top. The 4.75 mm (No. 4) sieve serves only to protect the 75 μ m (No. 200) sieve.

11.2 Place the washed test sample (as prepared in Section 10) in the mechanical washing vessel. Then add the amount of distilled or demineralized water as determined in 10.3, clamp the lid in place, and secure the vessel in the sieve shaker. Begin agitation after a period of 60 s has elapsed from the introduction ~~in~~ of the wash water. Agitate the vessel for 600 ± 15 s.

11.3 Immediately following the agitation period, take the vessel from the sieve shaker and remove the lid. Agitate the contents of the vessel by moving the upright vessel vigorously in a horizontal circular motion five or six times in order to bring the fines into suspension. Immediately pour the contents of the vessel into the nested 4.75-mm and 75- μ m (Nos. 4 and 200 (4.75-mm and

~~75- μ m)~~ 200) sieves placed in the pan provided to collect the wash water. Discard the material retained on the ~~No. 4 (4.75-mm)~~ 4.75-mm (No. 4) sieve. Collect all wash water and passing ~~No. 200 (75- μ m)~~ 75- μ m (No. 200) material in the collecting pan. To assure ensure that all material finer than ~~No. 200 (75- μ m)~~ 75- μ m (No. 200) sieve is washed through the sieve, take the following steps:

11.3.1 As the wash water is draining through the ~~No. 200 (75- μ m)~~ 75- μ m (No. 200) sieve, apply a jarring action to the sieve by lightly bumping the side of the sieve frame with the heel of the hand.

11.3.2 When a concentration of the material is retained on the ~~No. 200 (75- μ m)~~ 75- μ m (No. 200) sieve, rerinse the fine material by pouring the wash water through the sieve again. To rerinse the material:

11.3.2.1 Allow the wash water to stand undisturbed in the collection pan for a few moments to permit the heavier particles to settle to the bottom.

11.3.2.2 Pour the upper portion of the wash water into another container.

11.3.2.3 Pour the wash water back through the ~~No. 200 (75- μ m)~~ 75- μ m (No. 200) sieve and again collect all wash water and passing ~~No. 200 (75- μ m)~~ 75- μ m (No. 200) material in the collection pan.

11.3.2.4 Repeat the rinsing procedure as necessary until all of the ~~minus No. 200 (75- μ m)~~ 75- μ m (No. 200) material has been washed through the sieve.

11.4 Add distilled or demineralized water to bring the volume of dirty wash water to 1000 ± 5 ml. Then transfer the wash water to a vessel suitable for stirring and pouring.

11.5 Place a funnel in the graduated plastic cylinder. Stir the wash water by hand to bring the fines into suspension. While the water is still turbulent, pour enough of the wash water into the cylinder to bring the level of the liquid to the ~~15-in. (380-mm)~~ 380-mm (15-in.) mark.

11.6 Remove the funnel, place the stopper in the end of the cylinder, and prepare to mix the contents immediately.

11.7 Mix the contents of the cylinder by alternately turning the cylinder upside down and right side up, allowing the bubble to completely traverse the length of the cylinder 20 times in approximately 35 s.

11.8 At the completion of the mixing process, place the cylinder on the work table and remove the stopper. Allow the cylinder to stand undisturbed for 1200 ± 15 s. Then immediately read and record the height of the sediment column to the nearest ~~0.1 in. (2.5 mm)~~ 2.5 mm (0.1 in.).

NOTE 1—There are two unusual conditions that may be encountered in this phase of the test procedure. One is that a clearly defined line of demarcation may not form between the sediment and the liquid above it in the specified 20-min period. If this should occur in a test in which distilled or demineralized water is used, allow the cylinder to stand undisturbed until the clear demarcation line does form; then immediately read and record the height of the column of sediment and the total sedimentation time. If this should occur in a test in which tap water is used, discontinue the test and retest using an untested portion of the sample with distilled or demineralized water. The second unusual condition is that the liquid immediately above the line of demarcation may still be darkly clouded at the end of 20 min, and the demarcation line, although distinct, may appear to be in the sediment column itself. As for the first case, if tap water was used, rerun the test using a new sample with distilled or demineralized water; otherwise read and record this line of demarcation at the end of the specified 20-min sedimentation period as usual.

PROCEDURE B—FINE AGGREGATE

12. Test Sample Preparation

12.1 Split or quarter a representative portion from the material passing the ~~No. 4 (4.75-mm)~~ 4.75-mm (No. 4) sieve of sufficient mass to obtain an oven-dry mass of 500 ± 25 g.

12.2 Dry the preliminary test sample to constant mass at a temperature of ~~230 \pm 9°F (110 \pm 5°C)~~ 230 \pm 5°C (230 \pm 5°C): 9°F). Cool to room temperature.

12.3 Place the preliminary test sample in the mechanical washing vessel, add 1000 ± 5 ml of distilled or demineralized water, and clamp the vessel lid in place. Secure the vessel in the sieve shaker in sufficient time to begin agitation after 600 ± 30 s have elapsed from the introduction of the wash water. Agitate the vessel for a period of 120 ± 5 s.

12.4 After the 2-min agitation period is completed, remove the vessel from the shaker, unclamp the lid, and carefully pour the contents into the protected ~~No. 200 (75- μ m)~~ 75- μ m (No. 200) sieve described in 11.1. Rinse any remaining fines from the vessel onto the sieve. Direct the water (from flexible hose attached to a faucet) onto the aggregate until the water passing through the sieve comes out clear.

~~12.5 It may be necessary to~~

12.5 If necessary, flood clayey or silty samples prior to pouring them over the sieve to prevent clogging the ~~No. 200 (75- μ m)~~ 75- μ m (No. 200) sieve. Flood by adding water to the vessel following the agitation period. ~~R Use repeated flooding may be as necessary in extreme cases~~ before all of the contents of the vessel can be poured over the sieve.

12.6 Following the rinsing, transfer the material from the sieve to a drying pan, and dry to constant mass at a temperature of ~~230 \pm 9°F (110 \pm 5°C)~~ 230 \pm 9°F (110 \pm 5°C). It is necessary to wash the material from the ~~No. 200 (75- μ m)~~ 75- μ m (No. 200) sieve in order to transfer the retained material to a drying pan. Leave the pan in a slanting position until the free water that drains to the lower side becomes clear; then pour off this clear water. Use large shallow pans and spread the sample as thin as possible to speed drying.

12.7 Split or quarter the washed and dried material to provide a test sample of sufficient size to fill the ~~3 oz (85 mL)~~ 85 mL (3 oz) tin to level full. Predetermine the exact amount of material to be split using the following procedures.

- 12.7.1 Fill the measuring tin to overflowing with the prepared material.
 12.7.2 Consolidate the material in the tin by tapping the bottom edge with a hard object.
 12.7.3 Strike off to level full using a straight edge and determine the weight of the material.

NOTE 2—The use of a sample splitter meeting the requirements of Practice C 702 is considered preferable.

13. Procedure for Fine Aggregate

13.1 Conduct a sand equivalent test in accordance with Test Method D 2419, except use a mechanical shaker to continuously shake the cylinder and contents for 600 ± 15 s.

PROCEDURE C—AGGREGATES TOO FINE TO BE TESTED AS COARSE AGGREGATE AND TOO COARSE TO BE TESTED AS FINE AGGREGATE

14. Test Sample Preparation

14.1 Procedure C has been developed to test aggregates, such as pea gravel, and other aggregates contained primarily between the 9.5 and 1.18-mm ($\frac{3}{8}$ in. and No. ~~46~~ 16) sieves. Such aggregates are too fine to be tested as coarse aggregate and too coarse to be tested as sand.

14.2 Prepare a test sample using the procedure in Section 12, except eliminate the procedure of sieving and recombining the dry material as required in 12.7.

15. Procedure

15.1 Fill the plastic cylinder to the ~~4 102 \pm 0.1 in.~~ 102 2.5-mm (~~4 \pm 2.5-mm~~) 0.1 in. level with distilled or demineralized water. Pour the prepared test specimen into the cylinder using a funnel to avoid spillage. Tap the bottom of the cylinder sharply with the heel of the hand, as necessary, to release air bubbles and promote thorough wetting. Allow to stand undisturbed for 10 ± 1 min.

15.2 Stopper the cylinder, loosen the material from the bottom, and place the cylinder in the mechanical sand equivalent shaker. Start the timer and allow the machine to shake the cylinder and contents for 30 ± 1 min.

15.3 At the end of the shaking period, remove the cylinder from the shaker and transfer the water and passing ~~200 (75- μ m)~~ 75- μ m (No. 200) material to another cylinder containing ~~0.24 oz (7 mL)~~ 7 mL (0.24 oz) of stock calcium chloride solution, as follows:

15.3.1 Nest the 2.36-mm and 75- μ m (Nos. 8 and ~~200 (2.36-mm and 75- μ m)~~ 200) sieves into a funnel that empties into the second cylinder. Hold the mouth of the inverted cylinder over the nested sieves and remove the stopper, permitting the sample and water to pour onto the sieves. Rinse the remaining fines from the inverted cylinder onto the sieves with a small amount of fresh water. Rinse the material retained on the sieves with additional fresh water to ensure that all minus ~~No. 200 (75- μ m)~~ 75- μ m (No. 200) material passes through the sieve. Take care not to fill the cylinder above the ~~15-in. (380-mm)~~ 380-mm (15-in.) mark. Allow time for the water to drain through the sieves and then add enough fresh distilled water to bring the level of the liquid to the ~~15-in. (380-mm)~~ 380-mm (15-in.) mark. Stopper the cylinder and mix the contents by inverting 20 times in 35 s.

15.4 Allow the cylinder to stand undisturbed for 1200 ± 15 s from the time of completion of mixing, then read the top of the clay suspension to the nearest ~~0.1 in. (2.5 mm)~~ 2.5 mm (0.1 in.).

CALCULATION

16. Procedure A—Coarse Aggregate

16.1 Compute the durability index of the coarse aggregate to the nearest whole number using the following equation:

$$D_c = 30.3 + 20.8 \cot (0.29 + 0.15 H) \quad (3)$$

where:

D_c = durability index,

H = height of sediment, in., and the quantity $(0.29 + 0.15 H)$ is in radians.

16.2 Solutions of Eq 3 are given in Table 1.

17. Procedure B—Fine Aggregate

17.1 Calculate the durability index of the fine aggregate to the nearest 0.1 using the following equation:

$$D_f = \frac{\text{sand reading}}{\text{clay reading}} \times 100 \quad (4)$$

17.2 If the calculated durability index is not a whole number, report it as the next higher whole number. For example, if the clay reading was recorded as 8.0 and the sand reading was recorded as 3.3, the calculated durability index would be: $D_f = (3.3/8.0) \times 100$ or 41.2; report as 42.

17.3 If it is desired to average a series of values, average the whole number values as determined in 17.2. If the average of these values is not a whole number, round it to the next higher whole number as shown in the following example:

TABLE 1 Durability Index of Coarse Aggregate

 NOTE 1— $D_c = 30.3 + 20.8 \cot (0.29 + 0.15 H)$.

Sediment Height			Sediment Height			Sediment Height			Sediment Height			Sediment Height		
in.	mm	D_c	in.	mm	D_c	in.	mm	D_c	in.	mm	D_c	in.	mm	D_c
0.0	0.0	100	3.0	76.2	53	6.0	152.4	39	9.0	228.6	29	12.0	304.8	18
0.1	2.5	96	3.1	78.7	52	6.1	154.9	38	9.1	231.1	29	12.1	307.3	18
0.2	5.1	93	3.2	81.3	52	6.2	157.5	38	9.2	233.7	28	12.2	309.9	18
0.3	7.6	90	3.3	83.8	51	6.3	160.0	38	9.3	236.2	28	12.3	312.4	17
0.4	10.2	87	3.4	86.4	51	6.4	162.6	37	9.4	238.8	28	12.4	315.0	17
0.5	12.7	85	3.5	88.9	50	6.5	165.1	37	9.5	241.3	27	12.5	317.5	16
0.6	15.2	82	3.6	91.4	49	6.6	167.6	37	9.6	243.8	27	12.6	320.0	16
0.7	17.8	80	3.7	94.0	49	6.7	170.2	36	9.7	246.4	27	12.7	322.6	15
0.8	20.3	78	3.8	96.5	48	6.8	172.7	36	9.8	248.9	26	12.8	325.1	15
0.9	22.9	76	3.9	99.1	48	6.9	175.3	36	9.9	251.5	26	12.9	327.7	14
1.0	25.4	74	4.0	101.6	47	7.0	177.8	35	10.0	254.0	26	13.0	330.2	14
1.1	27.9	73	4.1	104.1	47	7.1	180.3	35	10.1	256.5	25	13.1	332.7	13
1.2	30.5	71	4.2	106.7	46	7.2	182.9	35	10.2	259.1	25	13.2	335.3	13
1.3	33.0	70	4.3	109.2	46	7.3	185.4	34	10.3	261.6	25	13.3	337.8	12
1.4	35.6	68	4.4	111.8	45	7.4	188.0	34	10.4	264.2	24	13.4	340.4	12
1.5	38.1	67	4.5	114.3	45	7.5	190.5	34	10.5	266.7	24	13.5	342.9	11
1.6	40.6	66	4.6	116.8	44	7.6	193.0	33	10.6	269.2	24	13.6	345.4	11
1.7	43.2	65	4.7	119.4	44	7.7	195.6	33	10.7	271.8	23	13.7	348.0	10
1.8	45.7	63	4.8	121.9	43	7.8	198.1	33	10.8	274.3	23	13.8	350.5	9
1.9	48.3	62	4.9	124.5	43	7.9	200.7	32	10.9	276.9	23	13.9	353.1	9
2.0	50.8	61	5.0	127.0	43	8.0	203.2	32	11.0	279.4	22	14.0	355.6	8
2.1	55.4	60	5.1	129.5	42	8.1	205.7	32	11.1	281.9	22	14.1	358.1	7
2.2	55.9	59	5.2	132.1	42	8.2	208.3	31	11.2	284.5	22	14.2	360.7	7
2.3	58.4	59	5.3	134.6	41	8.3	210.8	31	11.3	287.0	21	14.3	363.2	6
2.4	61.0	58	5.4	137.2	41	8.4	213.4	31	11.4	289.6	21	14.4	365.8	5
2.5	63.5	57	5.5	139.7	40	8.5	215.9	30	11.5	292.1	20	14.5	368.3	4
2.6	66.0	56	5.6	142.2	40	8.6	218.4	30	11.6	294.6	20	14.6	370.8	4
2.7	68.6	55	5.7	144.8	40	8.7	221.0	30	11.7	297.2	20	14.7	373.4	3
2.8	71.1	54	5.8	147.3	39	8.8	223.5	29	11.8	299.7	19	14.8	375.9	2
2.9	73.7	54	5.9	149.9	39	8.9	226.1	29	11.9	302.3	19	14.9	378.5	1
												15.0	381.0	0

Example—Calculated D_f values are 41.2, 43.8, and 40.9 which, when rounded to the next higher whole number, become 42, 44, and 41. The average of these values is then determined: $(42 + 44 + 41)/3 = 42.3$; and reported as 43.

18. Procedure C—Aggregates Too Fine to Be Tested as Coarse Aggregate and Too Coarse to Be Tested as Fine Aggregate

18.1 Calculate the durability index in accordance with Section 16.

PRECAUTION

19. Precautions

19.1 Perform the test in a location free of vibrations, because vibrations may cause the suspended material to settle at a greater rate than normal.

19.2 Do not expose the plastic cylinders to direct sunlight any longer than is necessary.

19.3 Frequently check the play between the cam and eccentric on the modified Tyler portable shaker by grasping one of the hanger rods and attempting to move the sieve base. If any play is noticed, replace the cam or bearing, or both.

19.4 Lubricate the sieve shaker at least each 3 months.

REPORT

20. Report

20.1 Report the “as-received” sieve analysis of the aggregate subjected to testing, the sieve analysis of the coarse sample used, and the sieve analysis of the fine sample used. Report the calculated durability index (D_c or D_f) with an indication as to whether Procedure A, B, or C was used.

~~20.2 The report should include~~

20.2 Include a statement as to whether or not strict temperature control was maintained, and whether tap, distilled, or demineralized water was used.

PRECISION AND BIAS

21. Precision and Bias

21.1 Criteria for judging the acceptability of the durability index values determined by this test method are very limited. The

data that are tabulated herein were developed by one state agency in the western United States on materials common to that geographical area. The criteria were established by performing 48 individual tests on each of six different aggregates, two of which were coarse aggregates and four of which were fine aggregates. Two tests by two operators in twelve laboratories were performed on each material.

21.2 An indication of the precision of this ~~method of test can be obtained from the data~~ method is presented in Table 2. The single-operator standard deviation and the multilaboratory standard deviation for both the durability index of coarse aggregate (D_c) and the durability index of fine aggregate (D_f) increases as the index decreases.

21.3 The maximum single-operator standard deviation has been found to be 3.58. Therefore, the results of two properly conducted tests by the same operator on the same material ~~should be not expected to~~ differ by more than 10.1.

21.4 The maximum multilaboratory standard deviation has been found to be 5.11. Therefore, the results of two properly conducted tests from two different laboratories on samples of the same aggregate ~~should be not expected to~~ differ by more than 14.4.

21.5 *Bias*—No information ~~can be~~ is presented on the bias of the procedure in this test method for measuring the durability index, because no material having an accepted reference value is available.

22. Keywords

22.1 aggregate degradation; aggregate durability

ASTM International takes no position respecting the validity of any patent rights asserted in connection with any item mentioned in this standard. Users of this standard are expressly advised that determination of the validity of any such patent rights, and the risk of infringement of such rights, are entirely their own responsibility.

This standard is subject to revision at any time by the responsible technical committee and must be reviewed every five years and if not revised, either reapproved or withdrawn. Your comments are invited either for revision of this standard or for additional standards and should be addressed to ASTM International Headquarters. Your comments will receive careful consideration at a meeting of the responsible technical committee, which you may attend. If you feel that your comments have not received a fair hearing you should make your views known to the ASTM Committee on Standards, at the address shown below.

This standard is copyrighted by ASTM International, 100 Barr Harbor Drive, PO Box C700, West Conshohocken, PA 19428-2959, United States. Individual reprints (single or multiple copies) of this standard may be obtained by contacting ASTM at the above address or at 610-832-9585 (phone), 610-832-9555 (fax), or service@astm.org (e-mail); or through the ASTM website (www.astm.org).

TABLE 2 Precision^A

Durability Index	Standard Deviation	Difference Two-Sigma Limits
<i>Coarse Aggregate.^B</i>		
Single-Operator Precision:		
60	3.58	10.1
65	3.07	8.7
70	2.56	7.2
75	2.04	5.8
80	1.53	4.3
85	1.01	2.9
Multilaboratory Precision:		
60	4.35	12.3
65	3.72	10.5
70	3.10	8.8
75	2.47	7.0
80	1.85	5.2
85	1.22	3.5
<i>Fine Aggregate.^C</i>		
Single-Operator Precision:		
50	2.40	6.8
55	2.24	6.3
60	2.08	5.9
65	1.92	5.4
70	1.76	5.0
75	1.61	4.5
Multilaboratory Precision:		
50	5.11	14.4
55	4.77	13.5
60	4.43	12.5
65	4.10	11.6
70	3.76	10.6
75	3.42	9.7

^A Preliminary analyses of data from California Transportation Laboratory study "Precision of Selected Aggregate Test Methods," 48 individual tests per material, 2 tests by 2 operators in 12 laboratories.

^B Data for two materials.

^C Data for four materials.