



# Standard Test Methods for Asphalt Content of Bituminous Mixtures by the Nuclear Method<sup>1</sup>

This standard is issued under the fixed designation D 4125; the number immediately following the designation indicates the year of original adoption or, in the case of revision, the year of last revision. A number in parentheses indicates the year of last reapproval. A superscript epsilon ( $\epsilon$ ) indicates an editorial change since the last revision or reapproval.

## 1. Scope

1.1 These test methods cover the procedures for determining the asphalt content of samples of uncompacted bituminous mixtures (Test Method A), and of laboratory compacted specimens of bituminous mixtures (Test Method B) by examining a test sample with an apparatus that utilizes neutron thermalization techniques.

1.2 The values expressed in SI units are regarded as the standard. The inch-pounds equivalents may be approximate.

1.3 *This standard does not purport to address all of the safety concerns, if any, associated with its use. It is the responsibility of the user of this standard to establish appropriate safety and health practices and determine the applicability of regulatory limitations prior to use. See Section 6 and Note 1, Note 4, and Note 6, for specific hazards.*

## 2. Referenced Documents

### 2.1 ASTM Standards:

- C 670 Practice for Preparing Precision and Bias Statements for Test Methods of Construction Materials<sup>2</sup>
- D 75 Practice for Sampling Aggregates<sup>3</sup>
- D 140 Practice for Sampling Bituminous Materials<sup>3</sup>
- D 979 Practice for Sampling Bituminous Paving Mixtures<sup>3</sup>
- D 1461 Test Method for Moisture or Volatile Distillates in Bituminous Paving Mixtures<sup>3</sup>
- D 1559 Test Method for Resistance to Plastic Flow of Bituminous Mixtures Using Marshall Apparatus<sup>3</sup>
- D 1561 Practice for Preparation of Bituminous Mixture Test Specimens by Means of California Kneading Compactor<sup>3</sup>
- D 3387 Test Method for Compaction and Shear Properties of Bituminous Mixtures by Means of the U.S. Corps of Engineers Gyrotory Testing Machine (GTM)<sup>3</sup>
- D 4013 Practice for Preparation of Test Specimens of Bituminous Mixtures by Means of Gyrotory Shear Compactor<sup>3</sup>

## 3. Significance and Use

3.1 These test methods are useful as a rapid, nondestructive

technique for determination of asphalt content of bituminous mixtures.

3.2 These test methods are suitable for quality control and acceptance testing for construction and for research and development applications. The test method is used for determination of asphalt content only as it does not provide extracted aggregate for gradation analysis.

3.3 The non-destructive nature of the test allows repetitive measurements to be made on a single test sample for statistical analysis of test data.

3.4 These test methods determine the asphalt content of a test sample by comparing the measured asphalt content with previously established calibration data.

3.4.1 The asphalt content of a material expressed as a percentage, is the ratio of the mass of asphalt in a given mass of material to the total mass of the sample or to the mass of the solid material particles.

## 4. Interferences

4.1 The fundamental assumptions inherent in this test method are that the material under test is homogeneous and that hydrogen present is in the form of asphalt or has been otherwise accounted for in the calibration process.

4.2 Accurate results will be dependent upon proper calibration of the apparatus to the material being tested.

4.3 This apparatus measures the total amount of hydrogen in the sample including hydrogen present in the form of water. Unless the test sample is free of water, such percentage must be determined in accordance with the provisions of Test Method D 1461 and the percentage determined subtracted from the asphalt percentage as measured by the apparatus.

4.3.1 Alternatively, the sample may be dried to a constant mass in an oven at  $110 \pm 5^\circ\text{C}$  ( $230 \pm 9^\circ\text{F}$ ), thereby nullifying the need for the correction.

4.4 This apparatus may be sensitive to outside influences, therefore, any other source of neutron radiation shall be kept at least 10 m (30 ft) from the apparatus during use. The area around the apparatus shall be kept free of large amounts of hydrogenous material, such as water, plastics or asphalt during use.

4.5 Moving the apparatus to a different location, even within the same laboratory, can cause a change in background radiation measurements. Also, if objects containing hydrogenous materials are moved in the area near the apparatus, the

<sup>1</sup> These test methods are under the jurisdiction of ASTM Committee D04 on Road and Paving Materials and is the direct responsibility of Subcommittee D04.25 on Analysis of Bituminous Mixtures.

Current edition approved May 15, 1994. Published July 1994. Originally published as D 4125 – 83. Last previous edition D 4125 – 92.

<sup>2</sup> *Annual Book of ASTM Standards*, Vol 04.02.

<sup>3</sup> *Annual Book of ASTM Standards*, Vol 04.03.

measurement counts may be affected. New background measurements shall be taken prior to use whenever background conditions have changed (see Section 10).

**5. Apparatus**

5.1 While exact details of construction for the apparatus may vary, the system shall consist of the following items:

5.1.1 *Neutron Source*— An encapsulated and sealed radioactive source such as americium/beryllium.

5.1.2 *Detectors*—Any type of thermal neutron detectors, such as helium-3 or boron trifluoride.

5.1.3 *Read-Out Instrument*, such as a scaler or a direct reading digital device calibrated in percent asphalt.

5.2 *Other Apparatus:*

5.2.1 *Stainless Steel Sample Pans*, of uniform size and mass.

5.2.2 *Balance*, capable of weighing to 20 kg (44 lb), readable to 1 g (0.0002 lbm).

5.2.3 *Oven*, capable of heating to  $177 \pm 3^\circ\text{C}$  ( $350 \pm 5^\circ\text{F}$ ).

5.2.4 *Straightedge*, steel, approximately 450 mm (18 in.) in length.

5.2.5 *Flat Plate*, metal or wood, having an area slightly larger than the sample pan. The metal plate shall have a minimum thickness of 10 mm ( $\frac{3}{8}$  in.). The wooden plate shall have a minimum thickness of 20 mm ( $\frac{3}{4}$  in.).

5.2.6 *Assorted Spoons and Mixing Bowls*.

5.2.7 *Thermometer* with a temperature range of 10 to  $250^\circ\text{C}$  (50 to  $482^\circ\text{F}$ ).

5.3 *Additional Apparatus for Test Method B:*

5.3.1 *Molded Laboratory Specimen Container*, (provided by instrument manufacturer) to allow for proper testing of laboratory compacted samples (see Fig. 1).

5.3.2 *Apparatus*, necessary to prepare compacted specimens as specified in Test Methods D 1559, D 1561, D 3387, or Practice D 4013.

**6. Hazards**

6.1 **Warning**—This equipment utilizes radioactive materials which may be hazardous to the health of the users unless proper precautions are taken. Users of this equipment must become completely familiar with possible safety hazards and with all applicable regulations concerning the handling and use of radioactive materials. Effective user instructions together with routine safety procedures are a recommended part of the operation of this apparatus.

**7. Sampling**

7.1 Obtain random samples of aggregates in accordance with Practice D 75.

7.2 Obtain random samples of freshly produced bituminous paving mixture in accordance with Practice D 979.

7.3 Obtain random samples of bituminous materials in accordance with Practice D 140.

**8. Calibration**

8.1 The test results obtained using this test method will be influenced by the types of aggregate, source and grade of asphalt, and by the mix gradation. Accordingly, a calibration curve must be developed for each mix type and aggregate blend to be tested under this test method.

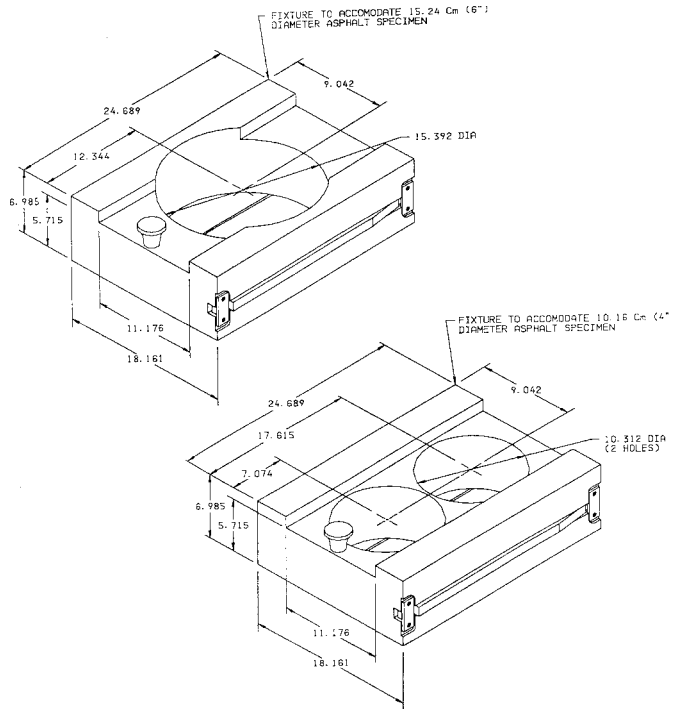

**FIG. 1 Molded Laboratory Specimen-Containers Measurement Values in SI Units (CM)—Other Values for Reference Only**

8.1.1 A new calibration curve shall be developed whenever there is a change in the source of asphalt or aggregate or a significant change in aggregate gradation.

8.1.2 A new calibration curve shall be established for new or repaired apparatus.

8.2 For Test Method A calibrate the apparatus using the following procedures:

8.2.1 Sample the aggregates in accordance with 7.1 and blend the aggregates in the proper proportions. Obtain enough aggregate for a minimum of three samples. Approximately 30 kg (65 lb) will be required, and

8.2.2 Sample the bituminous materials in accordance with 7.3. Approximately 2.5 kg (5.5 lb) will be required.

8.3 Use a minimum of three prepared samples to establish the calibration curve. The range of asphalt contents shall vary by at least two percent asphalt content from the lowest to the highest contents in the samples. The range shall encompass the asphalt content of the proposed mix design. The mass of the samples shall be within 10 g of each other.

8.3.1 Unless the apparatus makes provision for temperature corrections, all calibration samples shall be tested at a uniform temperature, within  $\pm 5^\circ\text{C}$  ( $9^\circ\text{F}$ ). Calibration samples should be prepared and tested as close as possible to the temperature of test samples of completed mixes.

8.4 Prepare a blank sample (sample of hot, dry aggregate without asphalt) to determine the mass to be used for calibration and plant mix samples. Using this mass will ensure the same average density for all test samples.

8.4.1 Thoroughly mix at least 10 kg (22 lb) of the aggregate after heating and drying it to a constant mass and temperature.

8.4.2 Fill a sample pan with the aggregate in two or three

layers, avoiding segregation. Using a scoop or spatula, distribute the aggregate to reduce voids and segregation. For each layer raise the pan approximately 20 to 50 mm (1 to 2 in.) from the working surface and tap the pan against the working surface two or three times to settle the contents. Fill the pan to a point slightly above the top edge. Slide a straightedge along the top of the pan until the aggregate is absolutely flush with the top edge of the pan.

NOTE 1—**Caution:** Do not compact the sample.

8.4.3 Determine the mass of the blank sample to the nearest gram and record data. Use this mass for all calibration and plant mix test samples. (See Note 3.)

8.4.4 Place the pan containing the blank sample in the apparatus and take a measurement in accordance with the manufacturer's instructions.

8.4.5 Record the blank sample count.

8.4.6 To detect changes in aggregate that may affect test results, a sample of aggregate may be prepared and tested each day as described herein. If a significant change in the count ( $\pm 0.5\%$ ) has occurred, then check the calibration as described in 9.3. If necessary, prepare a new calibration curve as outlined in 8.5 (see Note 2).

NOTE 2—Batch plant hot bin samples may be used to obtain the dry aggregate count. Care must be taken to ensure that the aggregate is completely dried and properly mixed before testing when using hot bin samples.

8.5 Prepare a minimum of three calibration samples using the following procedures:

8.5.1 Heat the aggregates and asphalt cement to approximately 150°C (300°F). Heat all bowls, sample pans, and tools to approximately 150°C (300°F).

8.5.2 To prevent samples from being biased by residual asphalt retained in the mixing bowl, do not clean the bowl after each mixing of the samples. Scrape it clean, leaving a coating of asphalt mix residue. This allows for a more accurate mixing of samples. Prior to mixing the first sample, a mixture of asphalt and aggregate fines may be used as a light coating on the interior of the mixing bowl.

8.5.3 Using an aggregate sample of sufficient size to fill the sample pan, add the proper amount of asphalt (within 1 g of desired percent by mass) and mix thoroughly in the mixing bowl.

8.5.4 Fill the sample pan in three layers. After placing each layer in the sample pan, using a scoop or spatula, distribute the layer of material evenly in the pan to reduce voids and segregation. Lift the pan approximately 20 to 50 mm (1 to 2 in.) and tap it on the working surface two or three times to settle the contents. The last layer should fill the pan to a point slightly above the top edge.

8.5.5 Determine the mass of the sample and add or subtract material until the mass is within 10 g of the mass of the blank sample.

NOTE 3—The mass of the blank sample may not be sufficient to completely fill the calibration and plant mix test sample pans for all mixes. The asphalt cement may act as a lubricant allowing additional consolidation of the aggregate particles. An adjusted blank sample mass may be determined by preparing a calibration sample using these procedures and

using the mass of this sample as the blank sample mass for this and all remaining samples.

8.5.6 Using a flat plate of wood or metal as a press, compress the sample until it is level with the top edge of the pan. Waxed paper may be used under the press to prevent asphalt sticking to the press.

NOTE 4—**Caution:** This is the only compactive effort the sample should receive.

8.5.7 Place the sample in the apparatus and take a timed measurement in accordance with the manufacturer's instructions.

8.5.8 Repeat this process for the remainder of the calibration samples.

8.6 For Test Method B calibrate the apparatus using the following procedures:

8.6.1 Sample the aggregates in accordance with 7.1 and prepare for blending in accordance with the laboratory compacted method to be used,

8.6.2 Sample the bituminous materials in accordance with 7.3.

8.6.3 At a minimum of four (4) known asphalt contents, prepare at least three (3) compacted specimens using Test Methods D 1559, D 1561, D 3387, or Practice D 4013. Vary the range of asphalt contents by at least 2 % from the lowest to the highest. The masses of each set of replicate specimens shall be within 10 g of each other.

NOTE 5—Specimens prepared for other purposes such as determining the laboratory mix design of bituminous mixtures may be used in this procedure, however, no other testing of the specimens should be done prior to performing this procedure.

8.6.3.1 Determine the mass of each specimen to the nearest gram,

8.6.4 For 10-cm (4-in.) specimens, select the two (2) specimens at each asphalt content having the mass nearest each other. For 15-cm (6-in.) specimens, select the one (1) specimen of each set that has a mass closest to the mass of the other specimens to be tested. The specimens not used in this process should be retained for use in other testing procedures in accordance with Note 5,

8.6.5 Place the specimens in the molded laboratory specimen container and place the container in the apparatus. Take timed measurements in accordance with the manufacturer's instructions, and

8.6.6 Repeat this process with each of the other three sets of calibration samples.

8.7 When using this procedure to prepare calibration curves for mixes containing recycled asphalt pavement (RAP) materials, the RAP material shall be of a uniform gradation, asphalt content, and asphalt type. In preparing calibration samples, the same percentage of RAP material shall be mixed in the calibration samples as the percentage being added in the mix.

8.7.1 If the RAP material is not uniform this method may be used for job control testing but should not be used for acceptance testing.

8.8 The final calibration response may be in the form of drawn curves, data tables, or equations for computer processing. Some apparatus will generate this response.

8.8.1 To be considered acceptable for use, a calibration

curve must have a correlation factor equal to or greater than 0.995 when calculated as follows:

$$\text{Correction factor} = \frac{n(\sum xy) - (\sum x)(\sum y)}{\sqrt{(n(\sum x^2) - (\sum x)^2)(n(\sum y^2) - (\sum y)^2)}} \quad (1)$$

where:

- $n$  = number of calibration samples,
- $x$  = calculated percent asphalt cement, and
- $Y$  = sample count.

## 9. Background and Stability Check

9.1 Obtain a background radiation count each day prior to taking test measurements. The measurement period for the background count shall be equal to or greater than the normal measurement period. Take the background radiation count in accordance with the manufacturer's recommended procedures.

9.2 Take a new background radiation count if the apparatus is moved, even within the same room, or if the environment around the apparatus has changed in a way that might influence the test results.

9.3 If the apparatus has not been moved since its previous usage, and the background count has changed less than 1 % from the previous background radiation count, then the apparatus shall be considered stable and acceptable for use. If the apparatus has been moved or if the surrounding conditions have changed, then a slightly larger change, 2 % to 3 %, may be considered acceptable. (See Note 6)

**NOTE 6**—The background radiation count is a necessary part of the operation of this apparatus and not a measurement of apparatus stability, however, it does give a good indication of the working condition of the apparatus.

9.4 If the background radiation counts are not within the suggested limits or if apparatus stability is suspect, then perform an apparatus statistical stability test in accordance with the manufacturer's recommended procedures prior to performing tests.

9.4.1 On new or repaired instruments, perform a statistical stability test prior to use.

9.4.2 At least once a month perform a statistical stability test to verify apparatus stability.

9.4.3 If the apparatus fails the statistical stability test, check to ensure that there is no large body of hydrogen or another source of neutron radiation in close proximity to the apparatus during the test and that the sample chamber is empty. Take another test at a longer measurement period. If it passes, then the apparatus may be considered acceptable for use. If this test fails, the apparatus shall be adjusted or repaired as recommended by the manufacturer before use.

## 10. Procedure

10.1 If recommended by the apparatus manufacturer to provide more stable and consistent results:

10.1.1 Turn on the apparatus prior to use to allow it to stabilize, and

10.1.2 Leave the power on during the day's testing.

10.2 Take a background radiation count.

10.3 Obtain a sample of freshly produced hot mix in accordance with 7.2.

10.4 For Test Method A, prepare a test sample in the following manner:

10.4.1 Fill the sample pan in three layers. After placing each layer in the sample pan, using a scoop or spatula, distribute the layer of material evenly in the pan to reduce voids and segregation. Lift the pan approximately 20 to 50 mm (1 to 2 in.) and tap it on the working surface two or three times to settle the contents. The last layer should fill the pan to a point slightly above the top edge,

10.4.2 Determine the mass of the sample and add or subtract material until the mass is within 10 g of the mass of the blank sample, and

10.4.3 Using a flat plate of wood or metal as a press, compress the sample until it is level with the top edge of the pan. Waxed paper may be used under the press to prevent asphalt sticking to the press.

**NOTE 7—Caution:** This is the only compactive effort the sample should receive.

10.5 Measure and record the sample temperature. Unless the apparatus makes provision for temperature corrections, all samples shall be tested at a temperature within  $\pm 5^\circ\text{C}$  ( $9^\circ\text{F}$ ) of the calibration samples.

10.6 Place the sample in the apparatus sample chamber and follow the manufacturer's instructions for operation of the equipment and the sequence of operation.

10.7 For Test Method B, prepare the specimens using the same procedures used in 8.6.3 to calibrate the apparatus.

10.7.1 Prepare the specimens with a mass as close as possible to the mass of the calibration specimens. For 10-cm (4-in.) specimens, make sure that the mass of the two specimens to be tested are within 10 g of each other and the average of the two within 10 g of the average of the calibration samples.

10.7.2 Place the specimens in the molded specimen container. Place the container in the apparatus and take timed measurements in accordance with the manufacturer's instructions.

10.8 Using the count of the reading and the calibration data, determine the asphalt content of the bituminous mixture (Note 8).

**NOTE 8**—Some instruments have built-in provisions to compute and display the asphalt content.

## 11. Report

11.1 Report the following information:

11.1.1 Make, model, and serial number of the apparatus,

11.1.2 Date and source of calibration,

11.1.3 Date of test,

11.1.4 Name of the operator,

11.1.5 Background radiation count for the day of the test,

11.1.6 Any adjustment data for the day of the test,

11.1.7 Mix identification,

11.1.8 Aggregate types and sources,

11.1.9 Asphalt source, type, and grade,

11.1.10 Test method used (Test Method A or B),

11.1.11 Blank sample mass (For Test Method A),

11.1.12 Blank sample count (For Test Method A),

11.1.13 Test sample mass (For Test Method A),

- 11.1.14 Test sample temperature (For Test Method A),
- 11.1.15 Mass of calibration specimens (Test Method B),
- 11.1.16 Mass of test specimens (Test Method B),
- 11.1.17 Count for each reading, if applicable, and
- 11.1.18 Asphalt content value to the nearest 0.1 % asphalt content expressed as a percentage of the total mass of the sample or to the mass of the solid material particles.

**12. Precision and Bias**

12.1 The apparatus count precision may be determined from the slope of the calibration curve and the standard deviation of the counts as follows:

$$P = \sigma/S \tag{2}$$

where:

- $P$  = apparatus precision, in % asphalt,
- $\sigma$  = standard deviation, in counts per automatically timed period, and
- $S$  = slope, in counts per % asphalt.

The standard deviation is calculated from 20 individual readings taken at the asphalt content of the mix being tested within  $\pm 1/2$  % of the mix design.

12.1.1 This precision applies only to apparatus count precision for repetitive measurements on the same sample.

12.2 A limited interlaboratory round-robin test program was conducted on Test Method A for the purpose of establishing

precision values based on the statistics for the optimum asphalt content mixture (Note 9). Table 1 lists those values.

12.3 The precision of the procedure of Test Method B has not been established yet. A precision statement for this test method is under development.

NOTE 9—The numerical data used to establish the precision of this test method was obtained from the University of Nevada-Reno Civil Engineering Department.<sup>4</sup>

12.4 *Bias*—The bias of the procedure in this test method cannot be determined because the apparatus is calibrated to the material under test and the bias is dependent upon proper calibration and sampling.

**13. Keywords**

13.1 asphalt content; bituminous mixtures; nuclear asphalt content; nuclear test procedure; quality control

<sup>4</sup> Report Number 6-331-950-1, *Precision of Methods for Determining Asphalt Content*, prepared for the National Asphalt Pavement Association, Oct. 10, 1987.

**TABLE 1 Precision**

Test and Type Index	Standard Deviation (1s) <sup>A</sup>	Acceptable Range of Two Test Results (d2s) <sup>A</sup>
Single Operator precision	0.16	0.45
Multilaboratory precision	0.23	0.65

<sup>A</sup>These numbers represent, respectively, the (1s) and (d2s) limits as described in Practice C 670.

*The American Society for Testing and Materials takes no position respecting the validity of any patent rights asserted in connection with any item mentioned in this standard. Users of this standard are expressly advised that determination of the validity of any such patent rights, and the risk of infringement of such rights, are entirely their own responsibility.*

*This standard is subject to revision at any time by the responsible technical committee and must be reviewed every five years and if not revised, either reapproved or withdrawn. Your comments are invited either for revision of this standard or for additional standards and should be addressed to ASTM Headquarters. Your comments will receive careful consideration at a meeting of the responsible technical committee, which you may attend. If you feel that your comments have not received a fair hearing you should make your views known to the ASTM Committee on Standards, at the address shown below.*

*This standard is copyrighted by ASTM, 100 Barr Harbor Drive, PO Box C700, West Conshohocken, PA 19428-2959, United States. Individual reprints (single or multiple copies) of this standard may be obtained by contacting ASTM at the above address or at 610-832-9585 (phone), 610-832-9555 (fax), or service@astm.org (e-mail); or through the ASTM website (www.astm.org).*