



# Standard Specification for Preformed Retroreflective Pavement Marking Tape for Extended Service Life<sup>1</sup>

This standard is issued under the fixed designation D 4505; the number immediately following the designation indicates the year of original adoption or, in the case of revision, the year of last revision. A number in parentheses indicates the year of last reapproval. A superscript epsilon ( $\epsilon$ ) indicates an editorial change since the last revision or reapproval.

## 1. Scope

1.1 This specification covers white or yellow preformed retroreflective pavement marking tape, that when applied to a road surface, will provide a service life normally greater than one year depending on the average daily traffic count (ADT).

1.2 The preformed retroreflective pavement tape is suitable for longitudinal markings and transverse markings including word/symbol markings. It is designed to be a pavement marking with extended service life.

1.3 The values stated in SI units are to be regarded as the standard.

## 2. Referenced Documents

### 2.1 ASTM Standards:

D 1000 Test Methods for Pressure-Sensitive Adhesive-Coated Tapes Used for Electrical and Electronic Applications<sup>2</sup>

D 1898 Practice for Sampling of Plastics<sup>3</sup>

D 4061 Test Method for Retroreflectance of Horizontal Coatings<sup>4</sup>

D 6628 Specification for Color of Pavement Marking Materials<sup>5</sup>

E 303 Test Method for Measuring Surface Frictional Properties Using the British Pendulum Tester<sup>5</sup>

E 1710 Test Method for Measurement of Retroreflective Pavement Marking Materials with CEN-Prescribed Geometry Using a Portable Retroreflectometer<sup>4</sup>

### 2.2 CIE Publications:<sup>6</sup>

No. 15.2 Colorimetry

No. 39.2 Recommendations for Surface Colours for Visual Signaling

## 3. Terminology

### 3.1 Definitions:

3.1.1 *extended service life or period, n*—a minimum service period of 12 months when placed in accordance with the manufacturers' recommended procedures on pavement surfaces having a daily traffic count not to exceed 15 000 ADT per lane.

3.1.1.1 *Discussion*—15 000 ADT per lane is typical of heavily traveled roads such as interstate highways through major urban areas. See also Section 7 for factors affecting durability.

3.1.2 *retroreflection, n*—reflection in which radiation is returned in directions close to the direction from which it came and maintained over wide variations of the direction of the incident radiation.

3.1.3 *surface pattern, n*—a pattern on the surface, in which the raised areas are a minimum of 0.8 mm (31 mils) high and occupy approximately 50 % of the surface area, presenting a substantial area of nearly vertical face to traffic from any approach.

3.1.4 *preformed tape, n*—continuous, flexible pavement marking material that is essentially complete and that may be affixed to or imbedded in the road surface without fundamentally altering its configuration.

## 4. Classification

4.1 *Preformed Retroreflective Pavement Marking Tape* shall be identified as:

4.1.1 Reflectivity Level I; Class 1, 2 or 3; Skid Resistance Level A, or B.

4.1.2 Reflectivity Level II; Class 1, 2 or 3; Skid Resistance Level A, or B.

### 4.2 Reflectivity Levels:

4.2.1 *Reflectivity Level I*—A tape that, when new, conforms to the retroreflectance requirements for Reflectivity Level I in Table 1 when measured in accordance with 6.4.

4.2.2 *Reflectivity Level II*—A tape that, when new, conforms to the retroreflectance requirements for Reflectivity Level II in Table 1 when measured in accordance with 6.4.

### 4.3 Classes:

4.3.1 *Class 1*—A tape without precoated adhesive, for application with liquid contact cement.

<sup>1</sup> This specification is under the jurisdiction of ASTM Committee D04 on Road and Paving Materials and is the direct responsibility of Subcommittee D04.38 on Highway Traffic Control Materials.

Current edition approved Dec. 10, 2001. Published February 2002. Originally published as D 4505 – 85. Last previous edition D 4505 – 01.

<sup>2</sup> *Annual Book of ASTM Standards*, Vol 10.01.

<sup>3</sup> Discontinued 1998; see *Annual Book of ASTM Standards*, Vol 08.01.

<sup>4</sup> *Annual Book of ASTM Standards*, Vol 06.01.

<sup>5</sup> *Annual Book of ASTM Standards*, Vol 04.03.

<sup>6</sup> CIE publications are available from USNC-CIE Publications Office, TLA Lighting Consultants, Inc. 7 Pond Street, Salem, MA 01970.

**TABLE 1 Retroreflectance Values for New, Dry Samples**

Entrance Angle	Observation Angle	Relativity Level	$R_L$ , mcd/m <sup>2</sup> /1×	
			White	Yellow
88.76	1.05	Reflectivity I	500	300
		Reflectivity II	250	175

4.3.2 *Class 2*—A tape with precoated pressure-sensitive adhesive, for application with or without surface preparation adhesive or primer.

4.3.3 *Class 3*—A tape with precoated pressure-sensitive adhesive protectively covered by an easily removable liner.

#### 4.4 Skid Resistance:

4.4.1 *Skid Resistance Level A*—A tape that, when new, has a skid resistance value of at least 45 BPN when tested in accordance with 6.6.

4.4.2 *Skid Resistance Level B*—A tape that, when new, has a skid resistance value of at least 55 BPN when tested in accordance with 6.6.

### 5. Ordering Information

5.1 The purchaser using this specification shall include the following information:

- 5.1.1 ASTM designation (D 4505),
- 5.1.2 Classification type for Retroreflectance (I or II; see 4.2),
- 5.1.3 Classification class for adhesive (1, 2, or 3; see 4.3),
- 5.1.4 Classification skid resistance level (A or B; see 4.4),
- 5.1.5 Daytime color (see 6.2),
- 5.1.6 Width and Length of rolls, and
- 5.1.7 Any additional information.

### 6. Requirements

#### 6.1 Physical Requirements:

6.1.1 The marking tape shall be flexible and shall conform to the typical road pavement surface.

6.1.2 The marking tape shall adhere to asphalt or portland cement concrete roadway surfaces when applied according to the manufacturer's recommended procedures on pavement surfaces having temperatures down to 10°C (50°F).

#### 6.2 Color:

6.2.1 The white and yellow marking tape shall conform to the requirements of Specification D 6628.

6.3 *Dimensions*—The marking tape as supplied shall be free of cracks, and have edges true, straight and unbroken. The actual width of rolls of preformed marking tape used for striping shall be no less than the nominal (stated) width and no more than 3 mm (1/8 in.) greater than the nominal width. The length shall be no less than the length stated.

6.4 *Retroreflection*—The marking tape shall be retroreflective, reflecting white or yellow, respectively, and shall be readily visible when viewed with automobile headlights at night and shall have minimum initial retroreflectance values as shown in Table 1 when measured in accordance with the photometric testing procedures of Test Method D 4061 or E 1710. Retroreflectance values shall be expressed as coefficient of retroreflected luminance ( $R_L$ ) in millicandelas per square metre per lux.

6.5 *Adhesion*—A sample of marking tape, 25.4 mm in width, applied according to the manufacturer's recommended

procedure and tested in accordance with Test Methods D 1000, shall have minimum adhesion values as shown in Table 2.

6.6 *Skid Resistance*—Skid resistance shall be tested in accordance with Test Method E 303.

NOTE 1—For tapes with a surface pattern, results often are quite variable. These tapes may be tested in a direction parallel to the flow of traffic and 45° from the direction of traffic, and the results averaged.

NOTE 2—Skid resistance levels of 45BPN correspond to tapes having exposed retroreflective glass beads. Higher levels of skid resistance are achievable with the addition of skid-resistance elements.

### 7. Durability and Wear Resistance

#### 7.1 Factors affecting durability and wear resistance:

7.1.1 Features of the pavement marking tape, such as thickness and wear surface material may affect durability. In general, thicker materials wear longer than thinner materials of the same composition. Wear surfaces composed of harder materials, such as urethanes, may be more durable than those made of softer materials like vinyl.

7.1.2 *Roadway characteristics affect durability*—Rough road surfaces, porous surfaces and high traffic volumes tend to decrease service life of markings. A high percentage of large vehicles tend to decrease service life. Encroachment or a lot of vehicles turning on top of the marking decreases service life. Techniques and materials used for control of ice and snow also affect durability.

7.1.3 Tapes that are inlaid into the road surface by grooving or hot rolling generally are more durable than the same tapes overlaid on the road surface.

7.2 Because no practical laboratory procedures have been determined to provide complete, reliable, predictive information on durability and wear resistance, the user is encouraged to seek information from alternate sources.

NOTE 3—The National Transportation Product Evaluation Program, administered by AASHTO, publishes data on the durability of many pavement marking tapes gathered from various annual test decks. These decks feature a wide variety of conditions, which may or may not be applicable to the user's needs.

### 8. Sampling

8.1 Statistically based sampling plans that are appropriate for each particular type or quantity may be used to obtain samples for use in determining compliance with this specification in accordance with Practice D 1898.

8.2 For purposes of developing purchase specifications, a lot size generally refers to the number of rolls in a lot. Sampling units are those rolls selected at random from the lot. A unit sample is the sample of tape taken from the roll.

### 9. Storage

9.1 *Storage*—The marking tape as supplied shall have a minimum shelf life of one year from date of purchase when

**TABLE 2 Adhesion**

Application Temperature, °C (°F)	Test Temperature, °C (°F)	Minimum Adhesion, N
10 (50)	10 (50)	4.88
24 (75)	24 (75)	4.88
46 (115)	46 (115)	4.88

stored at temperatures under 38°C (100°F).

## 10. Packaging and Marking

10.1 The marking tape shall be packaged in rolls and there shall be no more than three splices per 45.7 m (150 ft) of length.

10.2 The marking tape shall be packaged in accordance with accepted commercial standards.

## 11. Keywords

11.1 pavement marking; pavement marking tape; retroreflectance; tape

## ANNEX

### (Mandatory Information)

#### A1. DISCUSSION OF “30-METRE” GEOMETRY

A1.1 The European Committee for Standardization (CEN) originally developed the geometry used in this standard for measuring the retroreflectance of preformed tape (entrance angle 88.76° and observation angle 1.05°). The angles were derived using theoretically typical heights for headlamps and

drivers’ eyes. These heights were further simplified by assuming a single headlamp is mounted directly under the driver’s eye (see Fig. A1.1). The geometry is considered a good approximation for drivers viewing preformed tape on a flat road, 30 m ahead of a car. Practical measures of retroreflectance at distances beyond 30 m have not yet been developed.

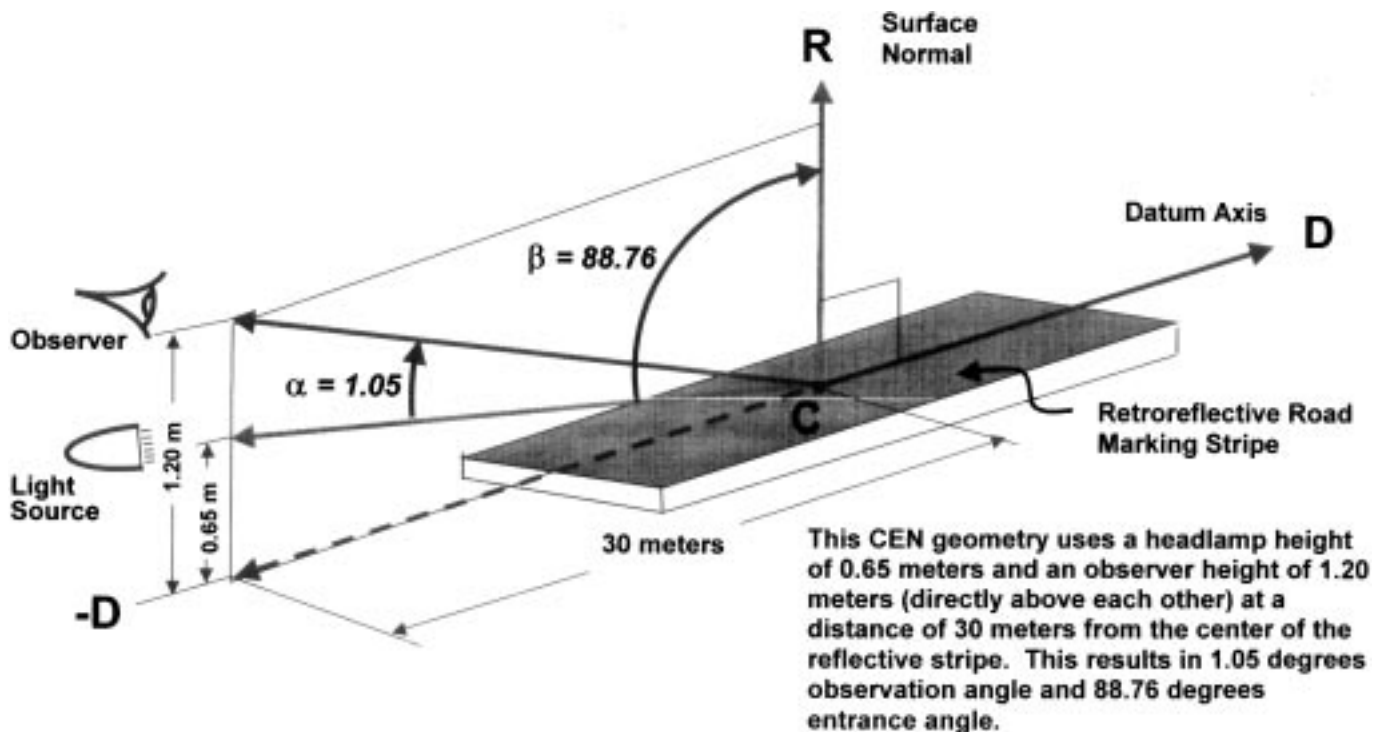

**FIG. A1.1 CEN 30 Meter Geometry—Observation and Entrance Angles for Simplified CEN Car**

*ASTM International takes no position respecting the validity of any patent rights asserted in connection with any item mentioned in this standard. Users of this standard are expressly advised that determination of the validity of any such patent rights, and the risk of infringement of such rights, are entirely their own responsibility.*

*This standard is subject to revision at any time by the responsible technical committee and must be reviewed every five years and if not revised, either reapproved or withdrawn. Your comments are invited either for revision of this standard or for additional standards and should be addressed to ASTM International Headquarters. Your comments will receive careful consideration at a meeting of the responsible technical committee, which you may attend. If you feel that your comments have not received a fair hearing you should make your views known to the ASTM Committee on Standards, at the address shown below.*

*This standard is copyrighted by ASTM International, 100 Barr Harbor Drive, PO Box C700, West Conshohocken, PA 19428-2959, United States. Individual reprints (single or multiple copies) of this standard may be obtained by contacting ASTM at the above address or at 610-832-9585 (phone), 610-832-9555 (fax), or service@astm.org (e-mail); or through the ASTM website (www.astm.org).*