

This document is not an ASTM standard and is intended only to provide the user of an ASTM standard an indication of what changes have been made to the previous version. Because it may not be technically possible to adequately depict all changes accurately, ASTM recommends that users consult prior editions as appropriate. In all cases only the current version of the standard as published by ASTM is to be considered the official document.



Designation: D 5167 – 91 (Reapproved 1997)



Designation: D 5167 – 03

Standard Practice for Melting of Hot-Applied Joint and Crack Sealant and Filler for Evaluation¹

This standard is issued under the fixed designation D 5167; the number immediately following the designation indicates the year of original adoption or, in the case of revision, the year of last revision. A number in parentheses indicates the year of last reappraisal. A superscript epsilon (ε) indicates an editorial change since the last revision or reappraisal.

¹ This practice is under the jurisdiction of ASTM Committee ~~D-4~~ D04 on Road and Paving Materials and is the direct responsibility of Subcommittee D04.33 on Formed-In-Place Sealants for Joints and Cracks in Pavements.

Current edition approved ~~Sept. 15, 1991~~; July 10, 2003. Published ~~November~~ September 2003. Originally approved in 1991. Last previous edition approved in 1997 as D 5167 – 91 (1997).

1. Scope

1.1 This ~~standard~~ practice establishes the procedure for melting or heating, or both, of hot-applied joint and crack sealants and fillers in preparation for the making of test specimens used in the laboratory evaluations of the sealants and fillers. Refer to the specific standard material specification for sampling requirements, test sample quantity, temperatures and times for melting and heating, and the number of specimens required for testing.

1.2 This ~~procedure~~ practice is applicable to the hot-applied joint and crack sealants and fillers used in both portland cement and asphaltic-concrete pavements.

1.3 The values stated in SI units are to be regarded as the standard. The values in parentheses are provided for information purposes only.

1.4 *This standard does not purport to address all of the safety concerns, if any, associated with its use. It is the responsibility of the user of this standard to establish appropriate safety and health practices and determine the applicability of regulatory limitations prior to use.* For specific precautions see Section 7.

~~1.4 The values stated in inch-pound units are to be regarded as the standard. The values in parentheses are provided for information purposes only.~~

2. Referenced Documents

2.1 *ASTM Standards:*

D 5535 Terminology Relating to Formed-in-Place Sealants for Joints and Cracks in Pavements²

E 1 Specification for ASTM Thermometers³

E 77 Test Method for the Inspection and Verification of Thermometers³

E 171 Specification for Standard Atmospheres for Conditioning and Testing Flexible Barrier Materials⁴

3. Terminology

3.1 *Definitions of Terms Specific—Refer to This Standard:*

3.1.1 ~~recommended safe heating temperature~~—~~The maximum temperature recommended by the manufacturer~~ Terminology D 5535 for definitions of the sealant or filler to which the sealant or filler can be heated and still conform to the particular specification requirements.

3.1.2 ~~recommended pouring following terms used in this specification: maximum heating temperature~~—~~The minimum temperature recommended by the manufacturer of the sealant or filler to which the sealant or filler can be heated and still conform to the particular specification requirements.~~

3.1.3 ~~recommended, minimum application temperature~~—~~any temperature between the recommended safe heating temperature and the recommended pouring temperature.~~

4. Significance and Use

4.1 It is intended that this practice be used by manufacturers, users, and testing agencies. The use of this practice establishes a uniform procedure for the melting or heating of hot-applied sealants and fillers. It is not intended to establish test procedures or conditions of test which are associated with each of the joint sealants and fillers.

² *Annual Book of ASTM Standards*, Vol T 04.03.

³ *Annual Book of ASTM Standards*, Vol ~~15.09~~; 14.03.

⁴ *Annual Book of ASTM Standards*, Vol 15.09.

5. Standard Conditions

5.1 The laboratory atmospheric conditions, hereinafter referred to as standard conditions, shall be as detailed in Specification E 171, ~~73.4~~ 23 ± 3.6°F (23.2°C (73.4 ± 2°C), 3.6°F) and 50 % relative humidity ± 5 %. The material shall be conditioned for 24 h at standard conditions before melting or heating.

6. Apparatus

6.1 Laboratory Melter:

6.1.1 The equipment for melting of the joint sealant or filler shall be an oil jacketed melter equipped with a mechanical agitator and thermometers for the oil bath and material in the melting vat.

6.1.2 The heat transfer oil shall be a high flash point oil, that is, in excess of ~~600°F (315°C)~~, 315°C (600°F).

6.1.3 The heat source shall be thermostatically controlled and capable of maintaining the heat transfer oil temperature within a tolerance of ~~± 5°F (± 3°C)~~ ± 3°C (± 5°F) and capable of heating the oil to a maximum of ~~550°F (288°C)~~, 288°C (550°F).

6.1.4 The mechanical agitator speed for the material shall be 30 ± 5 rpm when fully loaded and the agitator speed for the oil bath shall be such to allow continuous circulation of the oil.

6.1.5 Except when adding the sealant or filler sample, or checking temperature, the melter's pots shall be covered with close fitting lids.

6.1.6 Refer to Fig. 1 and Fig. 2 (bottom discharge type) and Fig. 3 (removable can type) for typical laboratory melters. Also see Note 1.

6.2 The thermometers used in this melting operation shall meet the requirements of Specification E 1 and be checked for calibration using Test Method E 77.

NOTE 1—The removable can type melter as shown in Fig. 3 is very similar in design to the melter shown in Fig. 1 and Fig. 2. Fig. 3's pots are designed to be removed so the melted material can be poured. Extra care must be taken when using this type of melter. Check the manufacturer's recommended safety procedures before use.

7. Precautions

7.1 Prior to beginning sampling and heating of sealants or fillers, a Material Safety Data Sheet must be obtained from the sealant or filler manufacturer so that proper safe handling techniques will be used.

7.2 ~~Safe~~ Maximum Heating Temperature —It is imperative that the manufacturer's ~~recommended safe~~ maximum heating temperatures be obtained for the material to be evaluated. The temperature of the material must not exceed the ~~safe~~ maximum heating temperature.

7.3 The laboratory melter unit should be located under an exhaust hood to disperse fumes.

7.4 Joint/crack sealants and fillers are manufactured from a variety of materials. To avoid compatibility problems, clean the melter so that it is free of all cleaning solvents and previously melted material.

8. Procedure

8.1 Sample Preparation:

8.1.1 Obtain the sample which is delivered to the laboratory for testing in accordance with its respective standard material specification.

8.1.2 *Solid Materials*— For sealants or fillers which are solid at ~~73.4~~ 23 ± 3.6°F (23.2°C (73.4 ± 2°C), 3.6°F), cut a complete vertical section from the material block as illustrated in Fig. 4, in order to obtain a uniform representative sample and supply enough product to pour all specimens. Also, if present, remove container liner by cutting it away. Consult the respective material specification for the required sample size and method of cutting. Cut the entire vertical section into segments of approximately 50 g and place all segments from one vertical section in the same pot and melt.

8.1.3 *Liquid Materials*— For sealants which are liquid at ~~73.4~~ 23 ± 3.6°F (23.2°C (73.4 ± 2°C), 3.6°F), stir the sealant to be sampled thoroughly by hand or mechanically using a suitable stirrer until the material consistency is uniform and homogeneous. Consult the respective material specification for the required sample size.

8.2 Heating Procedure:

8.2.1 Heat the oil bath to approximately 8 to 10°C above the ~~recommended safe~~ maximum heating temperature of the material to be tested (see 4.1 and 6.2) (refer to the respective material specification for the maximum oil bath temperature).

8.2.2 *Sample Addition*— The sample pot in the melting unit shall be clean and free of any residue from previous heated sealants or fillers as well as cleaning materials.

8.2.2.1 *Solid Materials*— Add four 50 ± 10 g portions of the sealant or filler into the melting unit's pot and, with the agitator running, bring the material to a pouring consistency not to exceed the manufacturer's ~~recommended safe~~ maximum heating temperature. Add the remaining segments at the rate of one 50 g segment/min, stopping the agitator (for not more than 10 s) while making the addition. If the sample size required by the respective material specification is too large to be melted in one pot, additional vertical samples must be obtained and melted to meet the correct sample size. All of the 50 g segments from one vertical section must be placed in the same pot and melted as part of the test. Keep the pot(s) covered at all times and the agitator running, except when adding segments of sealant or filler.

8.2.2.2 *Liquid Materials*— Immediately after stirring, add the entire sample portion at one time. If the sample size required by

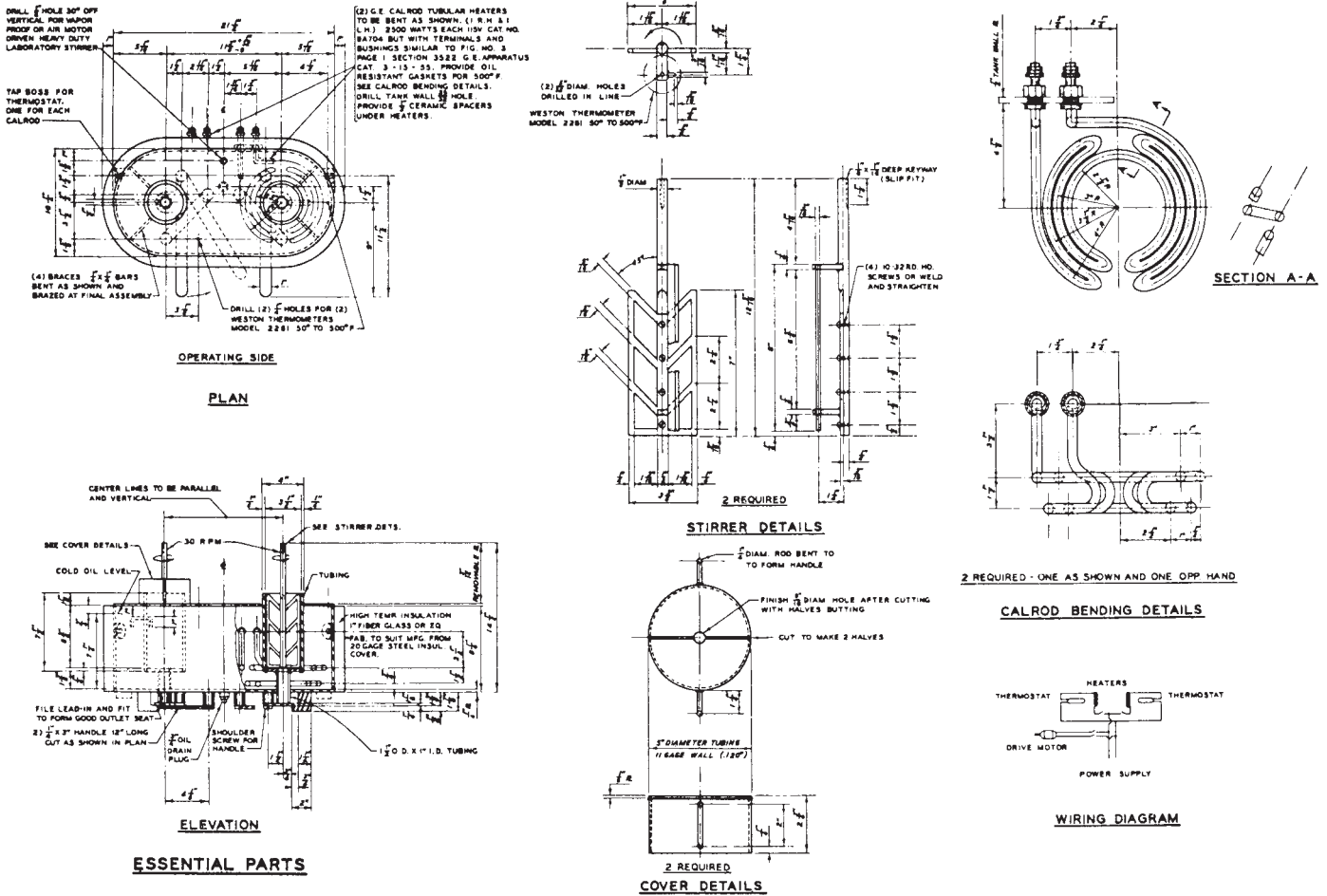

FIG. 2 Detailed Drawing of Joint Sealant Laboratory Melting Unit

8.2.4.2 When prolonged heating is required (see Note 2), the sample temperature shall be monitored at intervals not to exceed 30 min to verify conformance to temperature requirements. If material temperatures exceed the safe maximum heating temperature or drop below the pouring minimum application temperature after the pouring temperature has been reached, discard the sample and redo the heating. Maintain appropriate records of times and temperatures to verify conformance with specification requirements.

NOTE 2—Sometimes prolonged heating is required to verify that the material can meet all the requirements of the specification when prolonged heating situations happen in the field.

9. Sample Pouring

9.1 When using a melter with a bottom discharge, discard approximately the first 50 g of material and then pour all test specimens as required directly from the melter within a period of 10 min while continuing agitation.

9.2 When using a melter with a removable sample pot, stop the mechanical stirring device and then remove within one min. Immediately remove the sample pot from the melter and clean the oil residue from the outer pot surface. Pour all required specimens within 2 min following removal of the sample pot from the melter to minimize temperature loss.

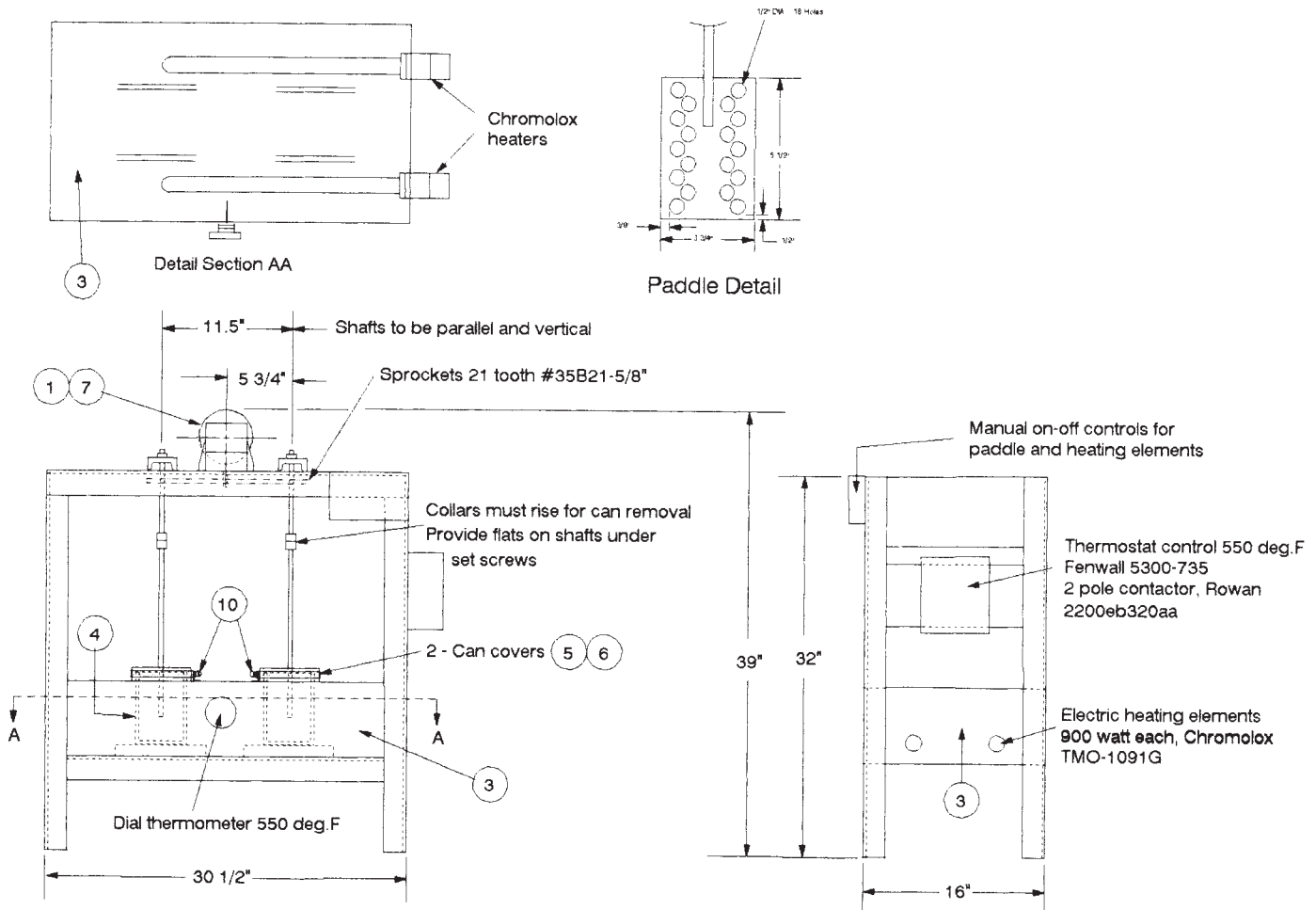

1. 1/8 hp Split phase motor 1140 r/min NEMA 56c
2. Paddles to turn 35 r/min
3. Heating bath capacity approx. 6 GPM
4. Cans submerged in oil bath
5. Use stock can No. 3600 Freud Can Co.
6. Can size 4 1/4 in. dia. by 7 in. tall
7. Gear reducer Boston No. F713-50-B5G
8. Bearing, Boston bronz No. FB101-14
9. All frame angles 2 in. by 2 in. by 3/16 in. welded at all joints
10. Clip attached to heating bath and hose clamp to keep pot from rotating

FIG. 3 Joint Sealant Laboratory Melting Unit

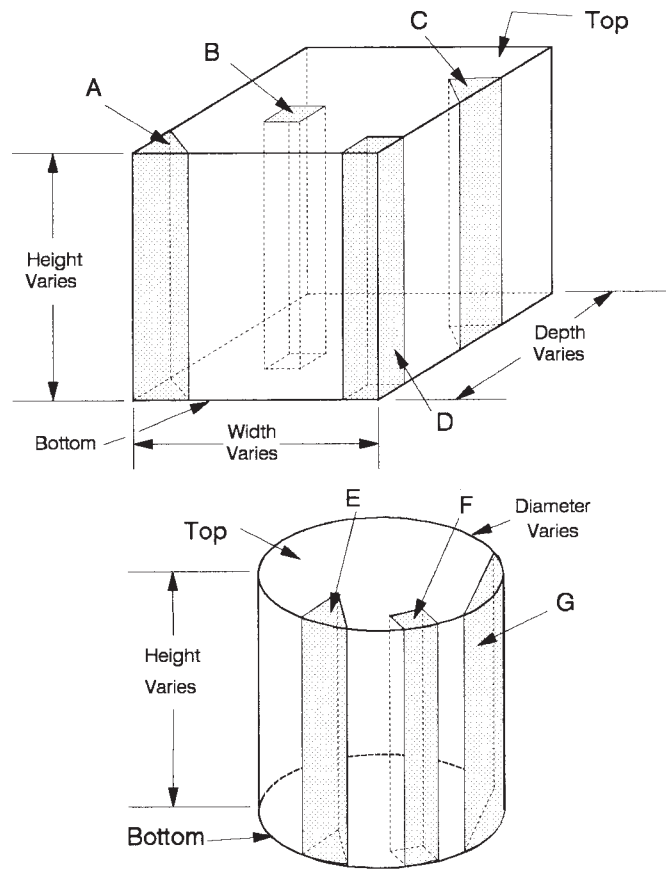

A,B,C,D,E,F & G are several typical vertical samples that can be taken from the manufacturer's original shipped sealant units.

FIG. 4 Typical Sealant Units (as supplied in manufacturer's original container)

ASTM International takes no position respecting the validity of any patent rights asserted in connection with any item mentioned in this standard. Users of this standard are expressly advised that determination of the validity of any such patent rights, and the risk of infringement of such rights, are entirely their own responsibility.

This standard is subject to revision at any time by the responsible technical committee and must be reviewed every five years and if not revised, either reapproved or withdrawn. Your comments are invited either for revision of this standard or for additional standards and should be addressed to ASTM International Headquarters. Your comments will receive careful consideration at a meeting of the responsible technical committee, which you may attend. If you feel that your comments have not received a fair hearing you should make your views known to the ASTM Committee on Standards, at the address shown below.

This standard is copyrighted by ASTM International, 100 Barr Harbor Drive, PO Box C700, West Conshohocken, PA 19428-2959, United States. Individual reprints (single or multiple copies) of this standard may be obtained by contacting ASTM at the above address or at 610-832-9585 (phone), 610-832-9555 (fax), or service@astm.org (e-mail); or through the ASTM website (www.astm.org).