



## Standard Test Method for Friction Coefficient Measurements Between Tire and Pavement Using a Variable Slip Technique<sup>1</sup>

This standard is issued under the fixed designation E 1859; the number immediately following the designation indicates the year of original adoption or, in the case of revision, the year of last revision. A number in parentheses indicates the year of last reapproval. A superscript epsilon ( $\epsilon$ ) indicates an editorial change since the last revision or reapproval.

### 1. Scope

1.1 This test method covers the measurement of the longitudinal friction coefficient with a measurement device that imposes braking-slip between a tire and a surface for the full range of braking-slip speed values.

1.2 This test method utilizes a series of incremental single measurements of friction force on a braked test wheel as it is pulled over a wetted or contaminated pavement surface. The rotational velocity of the braked wheel is feedback controlled in order to give a predetermined variable slip ratio gradient in accordance with set program parameters. The test wheel is kept under a constant static normal load and at a constant longitudinal speed of travel. Its major plane is perpendicular to the road plane and parallel to its direction of motion.

1.3 The values measured represent the friction properties obtained with the equipment and procedures stated in this test method and do not necessarily agree or correlate directly with those obtained by other pavement friction measuring methods.

1.4 The values are intended for use in:

1.4.1 Evaluating the braking friction forces on a pavement relative to that of other pavements.

1.4.2 Evaluating changes in the braking friction forces of a particular pavement with the passage of time.

1.4.3 Evaluating the changes in the braking friction force of a pavement when subjected to polishing wear and loss of macrotexture caused by traffic with passage of time.

1.4.4 Evaluating changes in the braking friction forces of a pavement contaminated with ice, moderate amounts<sup>2</sup> of slush and snow, pollen, vehicle oil spills and condensates from vehicle engine exhaust, and deposits from other pollution sources.

1.4.5 Evaluating the braking friction forces of a specimen tire on a clean or contaminated pavement.

1.5 The friction values reported by this test method are insufficient to determine the distance required to stop a vehicle on either a dry, wet, or contaminated pavement. They are also insufficient for determining the speed at which control of a vehicle would be lost.

<sup>1</sup> This test method is under the jurisdiction of ASTM Committee E-17 on Vehicle-Pavement Systems and is the direct responsibility of Subcommittee E17.21 on Field Methods for Measuring Tire Pavement Friction.

Current edition approved Jan. 10, 1997. Published May 1998.

<sup>2</sup> Slush thickness less than 25 mm (1 in.). Loose snow thickness less than 50 mm (2 in.).

1.6 The values stated in SI units are to be regarded as the standard. The inch-pound values given in parentheses are provided for information only.

1.7 *This standard does not purport to address all of the safety concerns, if any, associated with its use. It is the responsibility of the user of this standard to establish appropriate safety and health practices and determine the applicability of regulatory limitations prior to use.* Specific precautionary statements are given in Section 6 and Note 4.

### 2. Referenced Documents

#### 2.1 ASTM Standards:

E 178 Practice for Dealing with Outlying Observations<sup>3</sup>

E 274 Test Method for Skid Resistance of Paved Surfaces Using a Full-Scale Tire<sup>4</sup>

E 501 Specification for Standard Rib Tire for Pavement Skid-Resistance Tests<sup>4</sup>

E 524 Specification for Standard Smooth Tire for Pavement Skid Resistance Tests<sup>4</sup>

E 867 Terminology Relating to Traveled Surface Characteristics<sup>4</sup>

E 1136 Standard Specification for a Radial Standard Reference Test Tire<sup>4</sup>

E 1551 Specification for Special Purpose, Smooth-Tread Tire, Operated on Fixed Braking Slip Continuous Friction Measuring Equipment<sup>4</sup>

F 377 Practice for Calibration of Braking/Tractive Measuring Devices for Testing Tires<sup>5</sup>

F 457 Test Method for Speed and Distance Calibration of a Fifth Wheel Equipped With Either Analog or Digital Instrumentation<sup>5</sup>

F 559 Test Method for Measuring Length of Road Test Courses Using a Fifth Wheel<sup>5</sup>

### 3. Terminology

3.1 *Definitions:* The terminology used in this test method conforms to the terminology included in Terminology E 867.

3.2 *Definitions of Terms Specific to This Standard:*

3.2.1 *peak slip friction number, n*—the maximum value of the slip friction number.

<sup>3</sup> *Annual Book of ASTM Standards*, Vol 14.02.

<sup>4</sup> *Annual Book of ASTM Standards*, Vol 04.03.

<sup>5</sup> *Annual Book of ASTM Standards*, Vol 09.02.

3.2.1.1 *Discussion*—The peak slip friction number is written as  $SFN_{peak}(s)$  where  $s$  is the slip speed at which it occurred.

3.2.2 *slip friction number, n*—the quotient of the longitudinal friction force in the road plane over the normal load force at any instant in time and location, multiplied by 100.

3.2.2.1 *Discussion*—The slip friction number is denoted as  $sfn(t)$  for instantaneous values in time, or  $sfn(x)$  for instantaneous values in location. The notation  $SFN_{characteristic}$  specifies computed values or the slip friction number at a specified characteristic.

3.2.3 *slip speed, n*—the difference between the speed of the axis of the measuring wheel, which is equal to the traveling speed of the measuring device, and the speed of point on the perimeter of the rotating measuring wheel with undeflected radius,  $r$ .

3.2.4 *slip-to-skid friction number, n*—the value of the slip friction number at which the test wheel reaches zero rotational speed during a brake test.

3.2.4.1 *Discussion*—The slip-to-skid friction number is denoted  $SFN_{skid}(v)$  where  $v$  is the vehicle speed  $v$  at which slip-to-skid occurred.

3.2.5 *slope indicator*—the rate of change of the slip friction number expressed as an angle near the peak slip friction number.

3.2.6 *tire longitudinal stiffness indicator*—the rate of change of the slip friction number expressed as an angle near the zero value of the time or location.

#### 4. Summary of Test Method

4.1 The test apparatus consists of an automotive vehicle with one or two independently functioning test wheel systems incorporated into it. Each test wheel system contains a continuously variable brake system and a pavement wetting system. The test wheel is equipped with a standard pavement test tire, a reference tire, or a specimen tire as required for performing pavement surface measurements or tire comparisons, respectively. See 5.3 for standard tire references.

4.2 The overall system is controlled by a programmable control unit. The proper test control program is selected in the control unit for either pavement braking friction or tire comparison between a reference tire and a specimen tire.

4.3 The test apparatus is brought to the desired test speed. A controlled amount of water is optionally delivered ahead of the test tire and the braking system is actuated to control the slip ratio of the test wheel. As the brake is applied to the test wheel, the actual rotational velocity of the tire becomes less than the longitudinal component of the tire velocity. As a result of this velocity difference, commonly called the slip speed, a longitudinal force is generated called the longitudinal braking slip friction force.

NOTE 1—Water delivery is not used when testing during winter on ice or snow or at subzero temperatures.

4.4 The resulting resistive force from friction acting between the test tire and pavement surface is sampled, filtered, calculated, and recorded by suitable data acquisition routines.

The distance of travel of the test vehicle is added up over time and recorded with the aid of suitable digital fifth wheel instrumentation.

4.5 For tire comparison testing two identical test wheels, both are subjected to the same test run control logic for equal spin velocities and loads in parallel wheel paths on the same test track.

4.6 The braking slip friction coefficient of the paved road surface is calculated and reported as slip friction numbers,  $sfn(t)$ , at selected instances in time or traveled distance,  $sfn(x)$ .

4.7 The slip friction numbers are typically presented in a graphical form. See Fig. 1 for Cartesian plots of slip friction numbers versus slip speed or slip ratio with identification of:

- 4.7.1 Peak friction value,
- 4.7.2 Its corresponding critical slip ratio,
- 4.7.3 An estimated slip-to-skid friction number (similar to Test Method E 274 Skid Number, SN),
- 4.7.4 The slope of the tangent at zero slip speed of the curve, and
- 4.7.5 The slope of the logarithm curve of friction at high slip ratios.

#### 5. Apparatus

5.1 *Vehicle*—The host vehicle of the measuring system, with variable braking force applied, shall be capable of maintaining constant test speeds over the range of speed for the application. For example, speeds range up to 130 km/h at airports runways.

5.2 *Braking System*—The speed of the test wheel shall be controlled by a suitably rated brake system. For example, this may be accomplished by a hydraulic pump as a braking device. The pump can be installed in a closed hydraulic circuit such that the energy delivered by the test wheel is dissipated either by a hydraulic motor that augments the tow vehicle drive system or by a suitable pressure reduction valve and a thermal heat exchanger. See Fig. 2. The brake system shall be capable of maintaining controlled test wheel rotational velocities independent of influence by test speed and external forces acting

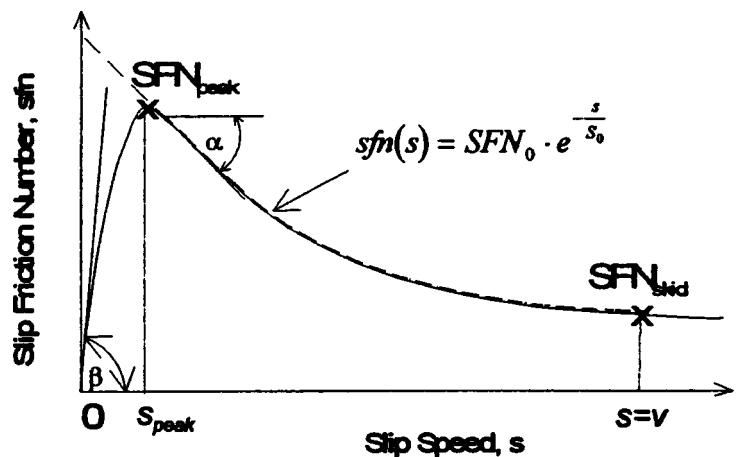
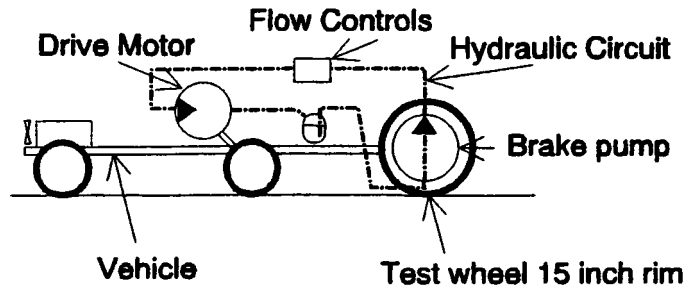

FIG. 1 Sample Slip Friction Number Trace Versus Slip Speed

For large tires:



For small tires:

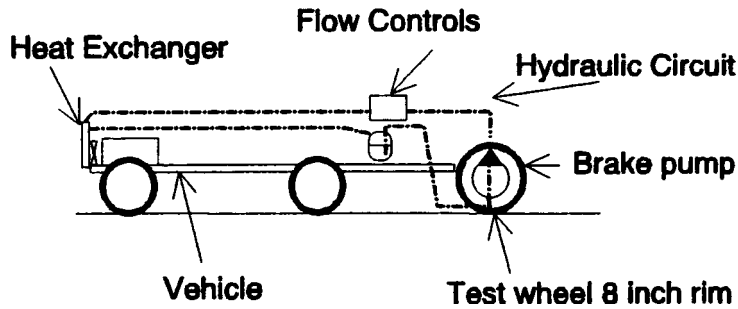

FIG. 2 Sample Brake Systems

upon the wheel. For example, it shall maintain fixed slip ratios within  $\pm 2\%$ .

5.3 Test Wheel Specifications and Loading—The load settings shall be the following for these nominal tire and rim<sup>6</sup> combinations:

5.3.1 Tire Rim 15 × 6 JJ:

5.3.1.1 Suitable test tires are given in Specifications E 501 and E 524, but note that data from the two tires are not interchangeable.

5.3.1.2 For these tires the normal load shall be  $4.8 \text{ kN} \pm 65 \text{ N}$  ( $1080 \pm 14.6 \text{ lbf}$ ). The inflation pressure shall be  $165 \pm 3 \text{ kPa}$  ( $24 \pm 0.5 \text{ psi}$ ).

5.3.2 Tire Rim 14 × 5.5 JJ—A suitable test tire is given in Specification E 1136. The normal load shall be  $4.8 \text{ kN} \pm 65 \text{ N}$  ( $1080 \pm 14.6 \text{ lbf}$ ). The inflation pressure shall be  $165 \pm 3 \text{ kPa}$  ( $24 \pm 0.5 \text{ psi}$ ).

5.3.3 Tire Rim 8 × 4—A suitable test tire is given in Specification E 1551. The normal load shall be  $1.423 \text{ kN} \pm 14 \text{ N}$  ( $320 \pm 3 \text{ lbf}$ ). The inflation pressure shall be  $207 \pm 3 \text{ kPa}$  ( $30 \pm 0.5 \text{ psi}$ ).

5.4 Instrumentation (See Fig. 3):

5.4.1 General Requirements for Measuring System—The instrumentation and control system shall conform to the

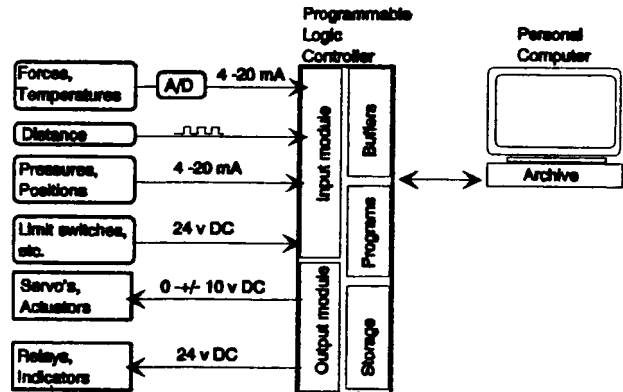

FIG. 3 Sample Instrumentation Scheme for Control and Measurements

following overall requirements at ambient temperatures between  $-20$  and  $40^\circ\text{C}$  ( $0$  and  $100^\circ\text{F}$ ):

5.4.1.1 The overall static system accuracy shall be  $\pm 2.0\%$  of the normal load for the particular test tire mounted. For the tire given in Specification E 524 with a normal load of  $4.8 \text{ kN}$  ( $1079 \text{ lbf}$ ), applied calibration force of the system output shall be within  $\pm 96 \text{ N}$  ( $21 \text{ lbf}$ ). For the tire given in Specification E 1551 with a normal load of  $1.423 \text{ kN}$  ( $320 \text{ lbf}$ ), applied calibration force of the system output shall be within  $\pm 28.5 \text{ N}$  ( $6.4 \text{ lbf}$ ).

<sup>6</sup> In accordance with Tire and Rim Association (TRA), 3200 W. Market St., Akron, OH 44313, USA.

NOTE 2—Dynamic system accuracy may be significantly poorer due to substantial inertial and gravitational effects on the test wheel and to the nature of the friction process, particularly at high friction values.

5.4.1.2 Time stability of calibration shall be one year, minimum.

5.4.1.3 The exposed portions of the system shall tolerate 100 % relative humidity (rain or spray) and all other adverse conditions, such as dust, shock, and vibrations that may be encountered in operations on paved surfaces.

5.4.1.4 A programmable logic controller, or other suitable digital computer, shall be used to monitor and control the overall instrumentation and collect, buffer, filter, smooth, calculate and put the measurements into storage in digital form. Scanning frequency for the data collection shall be 10 Hz or higher.

#### 5.4.2 Programmable Control System:

5.4.2.1 Input module shall be capable of sampling analog signal with a throughput of 50 Hz or higher. The resolution of transformation from analog to digital form shall be a minimum of 12-bits, corresponding to decimal number range 0 to 4095.

5.4.2.2 The clocking system shall have a minimum of a 10 kHz resolution.

5.4.2.3 The buffer shall have sufficient storage to contain minimum three consecutive unfiltered values of each force.

5.4.2.4 The storage area shall be sufficient to store one full test run of conditioned data.

5.4.3 *Force-Measuring Transducer*—The tire force measuring transducer shall be of such design as to measure the tire road interface force with no inertial effects. Transducers are recommended to provide an output directly proportional to force with hysteresis less than 1 % of the applied load, nonlinearity less than 1 % of the applied load up to the maximum expected loading, and sensitivity to any expected cross-axis loading or torque loading less than 1 % of the applied load. The force transducer shall be mounted in such a manner as to experience less than 1° angular rotation with respect to its measuring plane at the maximum expected loading.

5.4.4 *Additional Transducers*—Force transducers for measuring vertical load shall meet the recommendations stated in 5.4.3.

5.4.5 *Test Wheel Rotational Speed-Measuring Transducers*—Pulse encoders shall provide a distance resolution of 1.0 mm (0.04 in.) per 1 m, measured in the road plane. Speed shall be calculated at 10 Hz or higher and as the sum of distance pulses divided by the elapsed interval time.

#### 5.4.6 Vehicle Speed-Measuring Transducers:

5.4.6.1 Transducers in a separately mounted free-rolling wheel for vehicle speed measurement shall comply with the recommendations in 5.4.5.

5.4.6.2 Output shall be directly viewable for the driver.

#### 5.4.7 Signal Conditioning and Recorder System:

5.4.7.1 All signals shall be referenced to a common time base. All signal conditioning shall provide linear output and shall allow data reading resolution to meet the requirements of 5.4.1. Recording equipment shall be digital.

5.4.7.2 Raw force data shall be written to the buffer in a manner to enable first-in-first-out reading. Force data not passing the qualification routine of the program logic shall not

be used in the running calculation of  $sfn(t)$ . Qualified force data shall be filtered to remove high frequency noise. These filter-smoothed data shall be separately buffered in tables for use by the calculation routine of  $sfn(t)$ .

5.4.7.3 The measurements archive shall be organized in a file of records having specified formats. For each uniquely numbered test run there shall be a header record with general data, separate data collection records for each data sampling and a trailer record for file integrity control.

#### 5.5 Pavement Wetting System:

5.5.1 The quantity of water shall be applied such as to provide a nominal 0.5 mm (0.02 in.) thickness at any test speed and over the full width of test tire tread plus an additional 25 mm (1 in.).

5.5.2 A nozzle conforming to the dimensions in Fig. 1 of Test Method E 274 is suitable for use with the tires given in Specifications E 501, E 524, and E 1136. The nozzle configuration and position shall ensure that the water jet shall be directed toward the test tire and pointed toward the pavement at an angle of 20 to 30°. The water shall strike the pavement 250 to 450 mm (10 to 18 in.) ahead of the vertical axes through the centerline of the test wheel. The nozzle shall be 25 mm (1 in.) above the pavement or the minimum height required to clear obstacles that the test vehicle is expected to encounter, but in no case more than 100 mm (4 in.) above the pavement.

5.5.3 Water used for testing shall be reasonably clean and have no added chemicals, such as wetting agents or detergents.

## 6. Safety Precautions

6.1 The test vehicle, as well as all attachments to it, shall comply with all applicable state and federal laws. All necessary precautions shall be taken beyond those imposed by laws and regulations to ensure maximum safety of operating personnel and other traffic.

6.2 No test with water application shall be made when there is danger that the dispersed water may freeze on the pavement.

6.3 Observe all necessary precautions, particularly on contaminated pavements, to ensure a safe stopping distance of sufficient length between the friction measurement vehicle and other vehicles in traffic, as well as within road perimeters.

## 7. Calibration

7.1 *Distance and Speed*—Measure the circumference of the inflated tire mounted on the speed reference wheel and of the test tire mounted on its wheel using a flexible steel tape with markings in millimetres. Enter the measured circumference as measured to the nearest millimetre as a parameter to the control program. The control program will divide the circumference by the fixed number of encoder pulses per revolution to obtain the resolution in accordance with 5.4.5.

#### 7.2 Slip Friction Force:

7.2.1 Place the test wheel of the assembled unit, with its own instrumentation, on a suitable calibration platform, which has been calibrated in accordance with Test Method F 377, and load vertically to the test load. Measure the test wheel load within  $\pm 0.5$  % accuracy whenever the transducer is calibrated. Level the transducers both longitudinally and laterally, such that the tractive force sensitive axis is horizontal. This can be accomplished by minimizing the tractive force output for large

variation in vertical load. The system (vehicle or trailer) should be approximately level during this procedure.

7.2.2 The calibration platform shall utilize air bearings, or equivalent minimum friction bearings, and have an accuracy of  $\pm 0.5\%$  of the applied load and a hysteresis of  $\pm 0.25\%$  of the applied load up to the maximum expected loading. Take care to ensure that the applied load and the transducer sensitive axis are in the same vertical line. Perform the tractive force calibration incrementally to not less than 3.6 kN (800 lbf).

## 8. General Testing Information

### 8.1 Test Preparation:

8.1.1 Condition new tires by running them at or near their rated load and inflation pressure on the test vehicle (or on another suitable vehicle) at normal traffic speeds for at least 300 km (200 miles) or equivalent before they are used for test purposes.

8.1.2 Prior to each series of tests, warm up the tire by traveling for at least 10 km (5 miles) at normal traffic speeds and subjecting the test wheel to its test normal load without any braking action or self-wetting system on.

NOTE 3—This can be done as part of transportation from base to test site.

8.1.3 Inspect the tire for flat spots, damage, or other irregularities that may affect test results, and replace it if it has been damaged or is worn beyond the wear line.

8.1.4 Check the test wheel load and, if necessary, adjust immediately prior to each test series to within the value specified in 5.3.

8.1.5 Set the test tire inflation pressure at the value indicated in 5.3 at ambient temperature just before the 10 km (5 miles) warm-up.

### 8.2 Test Sections:

8.2.1 *General*—Test sections shall be defined as sections of pavement with uniform age and uniform composition that have been subjected to essentially uniform wear. For instance, sharp curves and steep grades shall not be included in the same test section with level tangent sections, nor shall passing lanes be included with traffic lanes.

8.2.1.1 Unless otherwise specified the length of each individual test distance shall be 150 m (500 ft).

8.2.1.2 Only take measurements on pavement sections that have the same and uniform visual contamination appearance.

8.2.1.3 Do not measure slush layers thicker than 25 mm (1 in.) and loose snow layers thicker than 50 mm (2 in.).

8.2.1.4 Test sections shall be defined within the operational limits set by the manufacturer of the variable slip device with regard to maximum grade and minimum curve radii for the proper use of the equipment.

### 8.2.2 Public Roads and Streets:

8.2.2.1 Make at least five measurements, at intervals not greater than 1 km (0.5 mile), in each test section with the test vehicle at the same lateral position in any one lane and at each specified test speed.

8.2.2.2 Consider the arithmetic average of all determinations to be the slip friction number of the test section. If statistical criteria applied to the slip friction number for a long test section indicate that it cannot be considered to be uniform,

treat the section as two or more sections. For treatment of the results of faulty test, see Section 11.

8.2.2.3 Testing shall be done in the center of the left wheel track of a traffic lane of a highway. A slip friction value for a highway surface may only be quoted without qualification if the test vehicle was so positioned during the test.

8.2.3 *Airport Runways, Stopways, and High-Speed Taxiways:*

8.2.3.1 Test sections shall be defined as each third of a runway length<sup>7</sup>. The thirds are called Section A, B, and C, where Section A is always the section associated with the lower runway designation number.

8.2.3.2 The distance between each test point shall be approximately 10 % of the usable length of the runway or such that each section shall have three tests carried out on it.

8.2.3.3 The objective of the test is to determine the mean friction values for Section A, B, and C. In addition, mean friction values can be estimated for smaller fixed sections of 150 m (500 ft) each or any length of runway.

### 8.2.4 Reference Tracks for Tire Testing:

8.2.4.1 For tire testing uniform pavement conditions throughout the test program are highly desirable. Repeated test runs along the same section of road shall therefore be performed in virgin wheel paths in parallel.

8.2.4.2 *Natural Wet Tracks*—When performing test runs during rainfall or immediately after rainfall, measurements may be performed without use of self-wetting facilities of the friction test vehicle. However, such testing conditions do not represent uniform conditions, and the measured results are not comparable with self-wetted test runs.

8.2.4.3 *Ice-Covered Tracks*—When performing test runs on ice, water film created from frictional melting, ice crystal history, ambient temperature, relative humidity, and other weather conditions influence the test results. For each pass of the test wheel over the surface, its characteristics will change. Repeated test runs along the same section of road should therefore be performed in separate and parallel wheel paths. These conditions do not represent uniform test conditions, and the measured results are not comparable.

8.2.4.4 *Hard-Packed Snow Tracks*—The information given in 8.2.4.3 applies.

### 8.3 Lateral Positioning of Test Wheel on Test Sections:

8.3.1 *Roads, Streets, and Highways*—Normally, testing shall be done in the center of the left wheel track of a traffic lane.

8.3.2 *Runways and High-Speed Taxiways*—Testing shall be done along two lines, each line parallel with the runway length. The distance of the lines from the center line should be approximately 3 m (10 ft.) or that distance from the center line at which most aircraft main gear assemblies traverse the runway.

### 8.4 Test Speeds:

8.4.1 With the variable slip technique friction forces are measured at several slip speeds during one test run with maximum slip speed being equal to the test vehicle speed.

<sup>7</sup> International Civil Aviation Organization: *Aerodromes*, Annex 14, Vol 1 and Attachments A and B.

8.4.2 Slip friction numbers at higher slip speeds may be estimated using the equation:

$$sfn(s) = SFN_0 \cdot e^{-\frac{s}{S_0}} \quad (1)$$

where:

- $sfn(s)$  = slip friction number for the test section of the pavement as measured by the test equipment,
- $SFN_0$  = slip friction number constant for the test section of the pavement as measured by the test equipment,
- $S_0$  = speed constant for the test section of the pavement as measured by the test equipment, and
- $s$  = independent variable slip speed.

NOTE 4—**Precaution:** For winter conditions during ambient air temperatures between +4 and -8°C, the test speed shall be 30 km/h (20 mph).

#### 8.4.3 Roads, Streets, and Highways:

8.4.3.1 For pavement maintenance planning objectives the standard test speed shall be 65 km/h (40 mph). Maintain test speeds within  $\pm 3$  km/h (1.5 mph).

8.4.3.2 For operational measurement objectives the test speed shall be chosen such that safe measurement operations are ensured under the given surface, meteorological, and traffic conditions during the time of measuring. A test speed of 65 km/h (40 mph) is recommended when achievable.

8.4.3.3 Where the legal maximum speed is less than 65 km/h (40 mph), the test may have to be conducted at a lower speed. Where the legal speed is considerably in excess of 65 km/h, tests may be made at the prevailing traffic speed, but it is recommended that at the same locations, additional tests be made at 65 km/h. Maintain test speeds within  $\pm 3.0$  km/h (1.5 mph).

#### 8.4.4 Runways, Stopways and High-Speed Taxiways:

8.4.4.1 The standard test speed shall be 65 km/h (40 mph). Maintain test speeds within  $\pm 3$  km/h (1.5 mph).

8.4.4.2 Optional additional test speeds for runways are 95 and 130 km/h (60 and 80 mph). Maintain test speeds within  $\pm 5$  km/h (2.5 mph).

8.4.5 *Tire Comparison*—The standard test speed shall be 65 km/h (40 mph) for all conditions. Maintain test speeds within  $\pm 3$  km/h (1.5 mph).

## 9. Procedure

9.1 Bring the apparatus to the desired speed. For testing conditions during non-freezing ambient air and ground temperatures, deliver water to the pavement ahead of the test tire in sufficient time prior to starting brake operation. Apply wheel brake gradually and incrementally in accordance with a chosen ramp-up schedule, so as to keep the wheel spinning at the predetermined initial constant slip ratio. The wheel shall remain at this slip ratio for the duration of the force data averaging interval.

9.2 After the data averaging interval is passed, increment the slip ratio to next higher value by applying sufficient amount of wheel brake. The wheel shall remain at this slip ratio for the duration of the force data averaging interval.

9.3 Repeat this incremental procedure until slip ratio has reached 90 % inclusive.

9.4 This procedure shall be prescribed in a computer

program loaded into a programmable controller for overall control of the test procedure.

9.5 Water delivery may be terminated as soon as the last data averaging interval is completed and the brake is released.

## 10. Calculation

10.1 The program shall calculate the slip fraction numbers,  $sfn(t)$ , from force-slip speed data set records in the digital controller buffer table.

### 10.2 Longitudinal Percent Slip:

10.2.1 The program shall calculate the longitudinal slip velocity and slip ratio from velocity data set records sampled at the same instant of time for the braked wheel(s) and speed reference wheel.

10.2.2 The longitudinal percent slip is defined by the following equation:

$$S = \frac{v - v_r}{v} \times 100 \% \quad (2)$$

where:

- $S$  = longitudinal percent slip,
- $v$  = longitudinal component of the true or free rolling velocity of the tire, corresponding to the velocity of the vehicle, and
- $v_r$  = longitudinal component of the braked or actual rolling velocity of the test tire.

10.2.3 The longitudinal slip velocity is defined by the following equation:

$$s = v \cdot \frac{S}{100} \quad (3)$$

where:

- $s$  = longitudinal slip velocity,
- $v$  = longitudinal component of the true or free rolling velocity of the tire, corresponding to the velocity of the vehicle, and
- $S$  = longitudinal percent slip.

### 10.3 Longitudinal Slip Friction Numbers:

10.3.1 The longitudinal slip friction numbers shall be calculated as the horizontal force,  $F_x$ , applied to the test tire at the tire-pavement contact patch, divided by the vertical force,  $F_z$ , exerted on the test wheel at the same instant of time. The dynamic value at each instant in time is called the dynamic longitudinal slip friction number,  $lsfn(t)$ .

10.3.2 The longitudinal slip friction number  $lsfn(t)$  is recorded in real time in computer registers and is available for both a data presentation program to draw various graphical result formats and data analysis programs to calculate and present quantitative result formats.

10.3.3 For the curve longitudinal slip friction number versus slip speed, which is normally subjected to log-linear regression analysis to establish a mathematical model for segments of the curve, additional curve slope calculation may be performed for the region following the peak value.

### 10.3.4 Peak Slip Friction Number and Critical Slip Ratio:

10.3.4.1 The program shall identify a sequence of maximum values for the force quotient  $F_x/F_z$  as calculated from the sampled, filtered, and smoothed data. The top three highest consecutive values in this sequence are calculated as the

arithmetic mean of three maximum values and presented as the peak slip friction number.

10.3.4.2 The slip ratio,  $S$ , for the corresponding three maximum values of force quotient is calculated as the arithmetic mean of slip at maximum friction and presented as the critical slip ratio.

10.3.5 *Slip-to-Skid Friction Number*—The slip value shall be controlled to some value less than or equal to 100 % that would be a locked wheel condition in order to avoid wear spots on the test tire. The values of the force quotient at the last five highest slip ratios in the test run are extrapolated after the test run by log - linear regression to estimate the force quotient at 100 % slip. This value is presented as the slip-to-skid friction number,  $SFN_{skid}(v)$ .

10.3.6 *Skid Number*—The skid number ( $SN$ ) shall be calculated as the slip-to-skid friction number times 100 (see Test Method E 274).

## 11. Faulty Tests

11.1 Test results that are manifestly faulty, or that differ by more than five  $SFN$  units from the average of all tests in the same test section, shall be treated in accordance with Practice E 178, as far as applicable.

## 12. Report

### 12.1 Highways:

12.1.1 *Field Report*—The field report for each test section shall contain data on the following items:

12.1.1.1 Location and identification of test section on road, street, or test track, including lane, wheel-path, direction of normal traffic travel, and direction of measurement,

12.1.1.2 Date and time of day,

12.1.1.3 *Weather Conditions*—Ambient air temperature, humidity, cloud cover, and wind, and

12.1.1.4 Peak slip friction number, critical slip speed, slip-to-skid friction number, speed of test, nominal normal load on test wheel, and ASTM tire designation.

12.1.2 *Summary Report*—The summary report shall include data for each test section on the following items insofar as they are pertinent to the variables or combinations of variables under investigation:

12.1.2.1 Location and identification of test section,

12.1.2.2 Number of lanes and presence of lane separators,

12.1.2.3 Grade and alignment,

12.1.2.4 Pavement type, mix, design of surface course, condition, and aggregate type (specific source, if available),

12.1.2.5 Age of pavement,

12.1.2.6 Annual average daily traffic,

12.1.2.7 Posted speed limit,

12.1.2.8 Date and time of day,

12.1.2.9 Weather conditions,

12.1.2.10 Lane and wheel-path tested,

12.1.2.11 Mean values for peak slip friction number and mean slip-to-skid friction number for the test section and speed at which the tests were made,

12.1.2.12 Plot of  $SFN$  versus slip ratio with markings for peak slip friction number and slip-to-skid friction number, and

12.1.2.13 Plot of  $SFN$ , test vehicle speed and slip ratio versus interval times for sampling during data acquisition.

### 12.2 Runways, Stopways, and High-Speed Taxiways:

12.2.1 *Field Report*—The field report for each runway test shall contain data on the following items:

12.2.1.1 Airport and designation of runway and location of stopway or taxiway,

12.2.1.2 Date and time of day,

12.2.1.3 *Weather Conditions*—dry and wet bulb temperatures, cloud cover, and wind,

12.2.1.4 Distance from centerline tested, and

12.2.1.5 Mean values for peak slip friction number, critical slip speed, slip-to-skid friction number in each test section, speed of test, nominal normal load on test wheel, and ASTM tire designation.

12.2.2 *Summary Report*—Test results are entered in forms specified by state civil aviation authorities.

### 12.3 Tire Comparison:

12.3.1 *Field Report*—The field report for each tire test shall contain data on the following items:

12.3.1.1 Location and description of test field and type of surface,

12.3.1.2 Date and time of day,

12.3.1.3 *Weather Conditions*—Dry and wet bulb temperatures, cloud cover, and wind,

12.3.1.4 Mean values for peak slip friction number, critical slip speed, slip-to-skid friction number in each test section, speed of test, nominal normal load on test wheel, and reference tire and their respective designations, and

12.3.1.5 Average time rate of change of the braking slip speed between the initial value and the peak.

## 13. Precision and Bias

13.1 *Precision*—Data is being collected in order to determine precision attainable with this test method. A statement regarding precision will be made in a future revision of this test method.

13.2 *Bias*—The relationship of the measured friction units to some “true” value of longitudinal friction has not been studied at this time. Bias determinations are not possible at this time due to the inability to establish a true value of friction for pavement surfaces.

**BIBLIOGRAPHY**

- (1) Kulakowski, B. T., Chi, M., and Lin, C., "Measurement and Modeling of Truck Tire Traction Characteristics," *Vehicle, Tire, Pavement Interface*, ASTM STP 1164, J. J. Henry and J. C. Wambold, Eds., ASTM, 1992, pp. 112–124.
- (2) International Civil Aviation Organization, "Aerodrome Design Manual," ICAO Doc 9157-AN/901, Part 3.
- (3) U. S. Patent No. 5 249 851, Oct. 5, 1993.
- (4) U.S. Patent No. 4 958 512, Sept. 25, 1990.
- (5) Jörnßen Reimpell, Helmut Stoll, *The Automotive Chassis: Engineering Principles*, Society of Automotive Engineers, 1996, pp. 79–96.
- (6) U. S. Patent No. 5 195 808, March 23, 1993.
- (7) National Aeronautics and Space Administration, "Mechanical Properties of Pneumatic Tires," *Technical Report R-64*, pp. 28–30.

*The American Society for Testing and Materials takes no position respecting the validity of any patent rights asserted in connection with any item mentioned in this standard. Users of this standard are expressly advised that determination of the validity of any such patent rights, and the risk of infringement of such rights, are entirely their own responsibility.*

*This standard is subject to revision at any time by the responsible technical committee and must be reviewed every five years and if not revised, either reapproved or withdrawn. Your comments are invited either for revision of this standard or for additional standards and should be addressed to ASTM Headquarters. Your comments will receive careful consideration at a meeting of the responsible technical committee, which you may attend. If you feel that your comments have not received a fair hearing you should make your views known to the ASTM Committee on Standards, 100 Barr Harbor Drive, West Conshohocken, PA 19428.*