



Designation: E 2034 – 99

Standard Practices for Simulating Truck Response to Longitudinal Profiles of Vehicular Traveled Surfaces¹

This standard is issued under the fixed designation E 2034; the number immediately following the designation indicates the year of original adoption or, in the case of revision, the year of last revision. A number in parentheses indicates the year of last reapproval. A superscript epsilon (ϵ) indicates an editorial change since the last revision or reapproval.

1. Scope

1.1 These practices cover the calculation of truck response to longitudinal profiles of traveled surface roughness.

1.2 These practices utilize computer stimulations to obtain two truck responses including: sprung and unsprung mass vertical displacement, velocity, and acceleration, sprung mass pitch angular displacement, velocity, and acceleration.

1.3 These practices present standard truck simulations (quarter truck, half-single unit truck, and half-tractor semi-trailer) for use in the calculations.

1.4 The values stated in SI units are to be regarded as the standard.

1.5 *This standard does not purport to address all of the safety concerns, if any, associated with its use. It is the responsibility of the user of this standard to establish appropriate safety and health practices and determine the applicability of regulatory limitations prior to use.*

2. Referenced Documents

2.1 ASTM Standards:

E 867 Terminology Relating to Traveled Surface Characteristics²

E 950 Test Method for Measuring the Longitudinal Profiles of Traveled Surfaces with an Accelerometer Established Inertial Profiling Reference²

2.2 ISO Standards:

2631 Guide for the Evaluation of Human Exposure to Whole-Body Vibration³

3. Terminology

3.1 See Terminology E 867.

4. Summary of Practice

4.1 These practices use a measured profile (see Test Method E 950) or a synthesized profile as a part of computer simulation to obtain truck response.

4.2 The first practice uses a standard truck simulation to obtain truck sprung mass vertical acceleration. The acceleration history can be computed as a function of time or distance. One application of this practice is to use the acceleration history in ride quality evaluation, such as the ISO Guide 2631. Another application is to use the sprung mass vertical displacement history as input to a suspended seat model in ride quality evaluation.

4.3 The second practice uses a truck simulation model to obtain tire/pavement vertical forces as a function of time or distance. One application of this practice is to use the tire/pavement history in pavement loading evaluation as described in Footnote 4.⁴

4.4 For all calculations, a truck speed is selected and maintained throughout the calculation. Pertinent information affecting the results must be noted.

5. Significance and Use

5.1 These practices provide a means for evaluating truck ride quality and pavement loading exerted by truck tires.

6. Apparatus

6.1 *Computer*—The computer is used to calculate truck response to a traveled surface profile, using a synthesized profile or a profile obtained in accordance with Test Method E 950 as the input. It is recommended that a 16 or more-bit digital computer be used.

6.2 *Data-Storage Device*—A data storage device shall be provided for the reading of profiles and the recording and long-term storage of computed data. Profile data shall be scaled to maintain resolution of 0.025 mm (0.001 in.) and to accommodate the full range of amplitudes encountered during normal profile-measuring operations. The devices shall not contribute to the recorded data any noise amplitude larger than 0.025 mm (0.001 in.)

6.3 *Simulation Input*—Digital profile recordings of road-roughness profiles shall be obtained in accordance with Test Method E 950 or synthesized. The profile must be recorded at intervals no greater than one third of the wavelength required

¹ These practices are under the jurisdiction of ASTM Committee E-17 on Pavement Technologies and are the direct responsibility of Subcommittee E17.33 on Methodology for Analyzing Pavement Roughness.

Current edition approved Sept. 10, 1999. Published October 1999.

² *Annual Book of ASTM Standards*, Vol 04.03.

³ Available from American National Standards Institute, 1430 Broadway, New York, NY 10018.

⁴ Todd, K.B., and Kulakowski, B.T., "Simple Computer Models for Predicting Ride Quality and Pavement Loading for Heavy Trucks," *Transportation Research Record* 1215, 1989, pp. 137–150.

TABLE 1 Quarter-Truck Model Parameters

Symbol	Single Unit Truck Front Axle	Single Unit Truck Rear Axle
M_s	2447.5 kg (14.0 lb•s ² /in.)	4003.5 kg (22.9036 lb•s ² /in.)
M_u	279.7 kg (1.6 lb•s ² /in.)	524.5 kg (3.0 lb•s ² /in.)
K	198251.1 N/m (1132. lb/in.)	1138367.4 N/m (6500. lb/in.)
C	2627.0 Ns/m (15. lb•s/in.)	2627.0 Ns/m (15. lb•s/in.)
K_1	788100.5 N/m (4500. lb/in.)	875667.3 N/m (5000. lb/in.)

TABLE 2 Half-Single Unit Truck Model Parameters

Symbol	Description	Numerical Value
M_s	One half vehicle sprung mass	6451.0 kg (36.9 lb•s ² /in.)
I_y	One half sprung mass pitch moment	46249.0 Nms ² (410876.4 lb•s ² /in.)
M_{u1}	One half front axle unsprung mass	279.7kg (1.6 lb•s ² /in.)
M_{u2}	One half rear axle unsprung mass	524.5kg (3.0 lb•s ² /in.)
K_1	Front suspension spring constant	198251.1 N/m (1132. lb/in.)
K_2	Rear suspension spring constant	1138367.4 N/m (6500. lb/in.)
C_1	Front suspension damping constant	2627.0 Ns/m (15. lb•s/in.)
C_2	Rear suspension damping constant	2627.0 Ns/m (15. lb•s/in.)
K_{t1}	Front tire spring constant	788100.5 N/m (4500. lb/in.)
K_{t2}	Rear tire spring constant	875667.3 N/m (5000. lb/in.)
A	Horizontal distance from front axle to sprung mass center of gravity	3.79 m (149.2 in.)
B	Horizontal distance from rear axle to sprung mass center of gravity	2.31 m (90.9 in.)

for accurate representation of the traveled surface for the intended use of the data. For most applications a sample interval of 0.15 m (0.5 ft) will give a valid representation for all types of road surfaces. When more than one path of a traveled surface is measured, the recorded profile data for the paths shall be at the same longitudinal location along the measured profiles to avoid phase shift between the paths. The recorded profile shall include all of the noted field data described in the Procedure (Data Acquisition) and Report sections of Test Method E 950. The length of the road-roughness profile must be reported with the results; however, caution must be exercised to ensure that transients in the simulation do not influence the results. It is recommended that at least 160 m (0.1 miles) of profile, preceding the test section, plus the desired test section be used as input in simulation to eliminate the effects of transients.

7. Truck Simulation Programs

7.1 These practices use one of the three truck simulation models described in Footnote 4: a quarter truck, a half-single unit truck, and a half-tractor semitrailer. To develop the mathematical models, the following was assumed:

- 7.1.1 Constant truck velocity,
- 7.1.2 No body or axle roll,
- 7.1.3 Rigid truck bodies,
- 7.1.4 Linear suspension and tire characteristics,
- 7.1.5 Point tire to road contact, and
- 7.1.6 Small truck pitch angles.

7.1.7 Although several methods for numerical solution of differential equations are available, the fourth-order Runge-Kutta method is employed in Footnote 4. The parametric models, shown in Figs. 1-3 constitute the standard practice. The analytic representations of the models and the methods of implementation need not be the same as outlined in the Appendix.

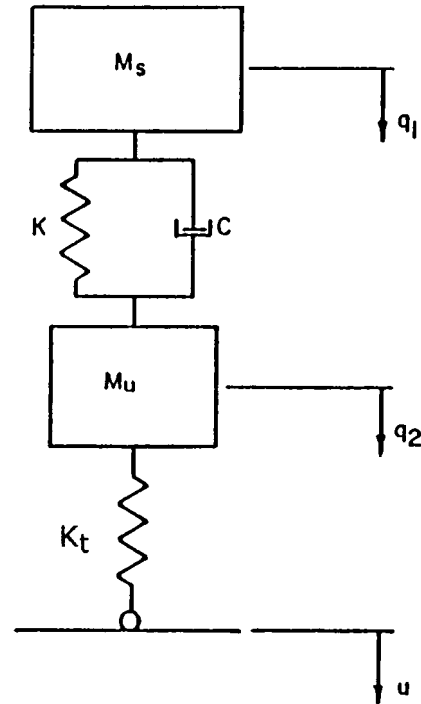

FIG. 1 Quarter-Truck Model

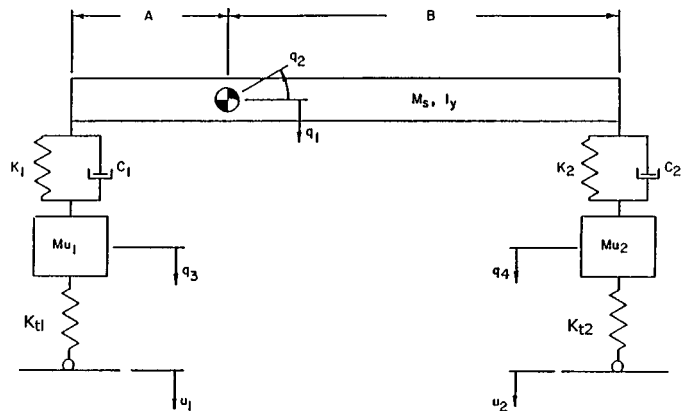

FIG. 2 Half-Single Unit Truck Model

7.2 *Quarter Truck Simulation Model*—The quarter truck model is shown in Fig. 1, with q_1 as the truck-body (sprung mass) displacement, q_2 as the tire (unsprung mass) displacement, and u as the road profile. The state variable equations of motion are given in X1.1. Two sets of model parameters, one for front axle and the other for rear axle, are given in Table 1. Front axle parameters should be used in ride comfort studies and rear axle parameters in pavement loading studies. The numerical values of the model parameters represent a fully loaded single unit, single-axle truck.

7.3 *Half-Single Unit Truck*—The half-single unit truck model is shown in Fig. 2. This model includes both front and rear axles, resulting in both a pitch and a heave mode of the truck motion being incorporated in the model. The state variable equations are given in X1.2, and the associated model parameters are listed in Table 2. The numerical values of the model parameters represent a fully loaded single unit single-axle truck.

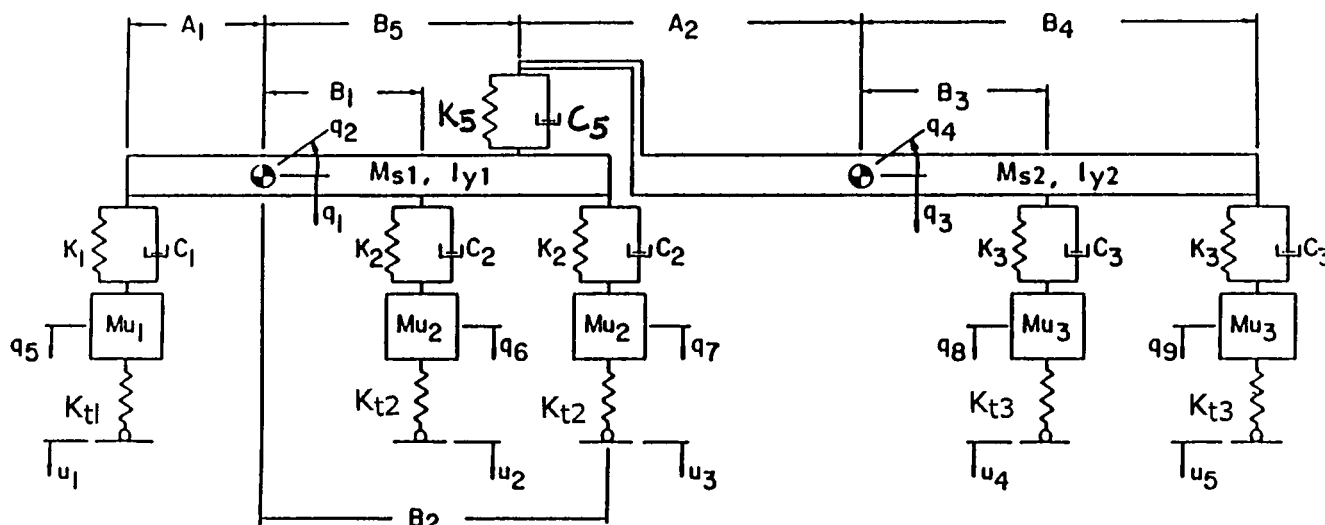

FIG. 3 Half-Tractor Trailer Model

7.4 *Half-Tractor Semitrailer Model*—The half-tractor semitrailer model is shown in Fig. 3. This model expands the half-single unit truck model to include tandem axles and a semitrailer. The fifth wheel connecting the tractor to the semitrailer is modeled with a stiff spring and damper. The state variable equations are given in X1.3, and the associated model parameters are listed in Table 3. The numerical values of the model parameters represent a fully loaded 18-wheel tractor semitrailer with the payload evenly distributed.

8. Calibration

8.1 There is no calibration involved in the use of these practices.

9. Report

9.1 Report the following information for this practice:

- 9.1.1 Description of the input profile data used in the simulation:
- 9.1.2 Truck simulation model used,
- 9.1.3 Speed of truck in simulations
- 9.1.4 Truck parameter values used if other than those specified in these practices, and
- 9.1.5 Results of the analysis.

TABLE 3 Model Parameters

Symbol	Description	Numerical Value
M_{s1}	One half tractor sprung mass	1818.2 kg (10.4 lb*s ² /in.)
I_{y1}	One half tractor sprung mass pitch moment	22655.4 Nm*s ² (200490.lb*s ² /in.)
M_{u1}	One half front axle unsprung mass	279.7 kg (1.6 lb*s ² /in.)
M_{u2}	One half tractor rear tandem axle unsprung mass (per axle)	524.5 kg (3.0 lb*s ² /in.)
K_1	Tractor front suspension spring constant	198251.1 N/m (1132. lb/in.)
K_2	Tractor rear suspension spring constant	1260960.8 N/m (7200. lb/in.)
C_1	Tractor front suspension damping constant	2627.0 Ns/m (15. lb*s/in.)
C_2	Tractor rear suspension damping constant	2627.0 Ns/m (15. lb*s/in.)
K_{t1}	Tractor front tire spring constant	788100.5 N/m (4500. lb/in.)
K_{t2}	Tractor rear tire spring constant	1576201.1 N/m (9000. lb/in.)
A_1	Horizontal distance from tractor front axle to tractor sprung mass center of gravity	1.53 m (60.1 in.)
B_1	Horizontal distance from tractor leading tandem axle to tractor sprung mass center of gravity	3.21 m (126.3 in.)
B_2	Horizontal distance from tractor trailing tandem axle to tractor sprung mass center of gravity	4.51 m (177.4 in.)
B_5	Horizontal distance from fifth wheel to tractor sprung mass center of gravity	3.01 m (188.7 in.)
M_{s2}	One half trailer sprung mass	14283.2 kg (81.7 lb*s ² /in.)
I_{y2}	One half trailer sprung mass pitch moment	10235.0 Nm*s ² (90575.5 lb*s ² /in.)
M_{u3}	One half trailer tandem axle unsprung mass (per axle)	58071.3 kg (1.9 lb*s ² /in.)
K_3	Trailer suspension spring constant	1313500.9 N/m (7500. lb/in.)
C_3	Trailer suspension damping constant	2627.0 Ns/m (15 lb*s/in.)
K_{t3}	Trailer tire spring constant	1751334.5 N/m (10000 lb/in.)
A_2	Horizontal distance from fifth wheel to trailer sprung mass center of gravity	5.98 m (235.6 in.)
B_3	Horizontal distance from trailer leading tandem axle to trailer sprung mass center of gravity	5.60 m (220.4 in.)
B_4	Horizontal distance from trailer trailing tandem axle to trailer sprung mass center of gravity	6.82 m (268.4 in.)
C_5	Fifth wheel damping constant	175133.5 Ns/m (1000 lb*s/in.)
K_5	Fifth wheel spring constant	17513345 N/m (100000. lb/in.)

APPENDIX

(Nonmandatory Information)

X1. EQUATIONS OF MOTION FOR TRUCK RESPONSES TO LONGITUDINAL PROFILES

X1.1 *Quarter Truck Model*—The state variable equations for this model are as follows:

$$\begin{aligned} \dot{q}_1 &= q_3 \\ \dot{q}_2 &= q_4 \\ \dot{q}_3 &= (1/M_s) [C(q_4 - q_3) + K(q_2 - q_1)] \\ \dot{q}_4 &= (1/M_u) [C(q_3 - q_4) + K(q_1 - q_2) + K_1(u - q_2)] \end{aligned} \tag{X1.1}$$

where:

- q_1 = vertical displacement of sprung mass,
- q_2 = vertical displacement of unsprung mass,
- q_3 = vertical velocity of sprung mass,
- q_4 = vertical velocity of unsprung mass, and
- u = road elevation profile.

X1.2 *Half-Single Unit Truck*—The state variable equations for this model are as follows:

$$\begin{aligned} \dot{q}_1 &= q_5 \\ \dot{q}_2 &= q_6 \\ \dot{q}_3 &= q_7 \\ \dot{q}_4 &= q_8 \\ \dot{q}_5 &= (1/M_s) \{C_1(q_7 - q_5 - Aq_6) + C_2(q_8 - q_5 + Bq_6) \\ &\quad + K_1(q_3 - q_1 - Aq_2) + K_2(q_4 - q_1 + Bq_2)\} \\ \dot{q}_6 &= (1/I_y) \{C_1A(q_7 - q_5 - Aq_6) + C_2B(q_8 - q_5 + Bq_6) \\ &\quad + K_1A(q_3 - q_1 - Aq_2) + K_2B(q_4 - q_1 + Bq_2)\} \\ \dot{q}_7 &= (1/M_{u1}) \{C_1(q_5 - q_7 + Aq_6) + K_1(q_1 - q_3 + Aq_2) + K_{r1}(u_1 - q_3)\} \\ \dot{q}_8 &= (1/M_{u2}) \{C_2(q_5 - q_8 - Bq_6) + K_2(q_1 - q_4 + Bq_2) + K_{r2}(u_2 - q_4)\} \end{aligned} \tag{X1.2}$$

where:

- q_1 = vertical displacement of sprung mass,
- q_2 = pitch angular displacement of sprung mass,
- q_3 = vertical displacement of front unsprung mass,
- q_4 = vertical displacement of rear unsprung mass,
- q_5 = vertical velocity of sprung mass,
- q_6 = pitch angular velocity of sprung mass,
- q_7 = vertical velocity of front unsprung mass,
- q_8 = vertical velocity of rear unsprung mass,
- u_1 = Elevation profile of road under front wheel, and
- u_2 = Elevation profile of road under rear wheel.

X1.3 *Half-Tractor Semitrailer Model*—The state variable equations for this model are as follows:

$$\begin{aligned} \dot{q}_1 &= q_{10} & \dot{q}_4 &= q_{13} & \dot{q}_7 &= q_{16} \\ \dot{q}_2 &= q_{11} & \dot{q}_5 &= q_{14} & \dot{q}_8 &= q_{17} \\ \dot{q}_3 &= q_{12} & \dot{q}_6 &= q_{15} & \dot{q}_9 &= q_{18} \end{aligned} \tag{X1.3}$$

$$\begin{aligned} \dot{q}_{10} &= (1/M_{s1}) \{C_1(q_{14} - q_{10} + A_1q_{11}) + C_2[q_{15} + q_{16} - 2q_{10} + (B_1 + B_2)q_{11}] \\ &\quad + C_5(q_{12} - q_{10} + B_5q_{11} + A_2q_{13}) + K_1(q_5 - q_1 - A_1q_2) \\ &\quad + K_2[q_6 + q_7 - 2q_1 + (B_1 + B_2)q_2] + K_5(q_3 - q_1 + B_5q_2 + A_2q_4)\} \\ \dot{q}_{11} &= (-1/I_{y1}) \{C_1A_1(q_{10} - q_{14} + A_1q_{11}) + K_1A_1(q_5 - q_1 - Aq_2) \\ &\quad + C_2[B_1q_{15} + B_2q_{16} - (B_1 + B_2)q_{10} + (B_1^2 + B_2^2)q_{11}] \\ &\quad + C_5B_5(q_{12} - q_{10} + B_5q_{11} + A_2q_{13}) + K_2[B_1q_6 + B_2q_7 - (B_1 + B_2)q_1 \\ &\quad + (B_1^2 + B_2^2)q_2] \\ &\quad + K_5B_5(q_3 - q_1 + B_5q_2 + A_2q_4)\} \\ \dot{q}_{12} &= (1/M_{s2}) \{C_3[q_{17} + q_{18} - 2q_{12} + (B_3 + B_4)q_{13}] + C_5(q_{10} - q_{12} \\ &\quad - B_5q_{11} - A_2q_{13}) \\ &\quad + K_3[q_8 + q_9 - 2q_3 + (B_3 + B_4)q_4] + K_5(q_1 - q_3 - B_5q_2 - A_2q_4)\} \\ \dot{q}_{13} &= (-1/I_{y2}) \{C_3(B_3q_{17} + B_4q_{18} - (B_3 + B_4)q_{12} + (B_3^2 + B_4^2)q_{13}) \\ &\quad + C_5A_2(q_{12} - q_{10} + B_5q_{11} + A_2q_{13}) \\ &\quad + K_3(B_3q_8 + B_4q_9 - (B_3 + B_4)q_3 + (B_3^2 + B_4^2)q_4) \\ &\quad + K_5A_2(q_1 - q_3 + B_5q_2 + A_2q_4)\} \\ \dot{q}_{14} &= (1/M_{u1}) \{C_1(q_{10} - q_{14} + A_1q_{11}) + K_1(q_1 - q_5 + A_1q_2) + K_{r1}(u_1 - q_5)\} \\ \dot{q}_{15} &= (1/M_{u2}) \{C_2(q_{10} - q_{15} - B_1q_{11}) + K_2(q_1 - q_6 - B_1q_2) + K_{r2}(u_2 - q_6)\} \\ \dot{q}_{16} &= (1/M_{u2}) \{C_2(q_{10} - q_{16} - B_2q_{11}) + K_2(q_1 - q_7 - B_2q_2) + K_{r2}(u_3 - q_7)\} \\ \dot{q}_{17} &= (1/M_{u3}) \{C_3(q_{12} - q_{17} - B_3q_{13}) + K_3(q_3 - q_8 - B_3q_4) + K_{r3}(u_4 - q_8)\} \\ \dot{q}_{18} &= (1/M_{u3}) \{C_3(q_{12} - q_{18} - B_4q_{13}) + K_3(q_3 - q_9 - B_4q_4) + K_{r3}(u_5 - q_9)\} \end{aligned}$$

where:

- q_1 = vertical displacement of tractor sprung mass,
- q_2 = pitch angular displacement of tractor sprung mass,
- q_3 = vertical displacement of trailer sprung mass,
- q_4 = pitch angular displacement of trailer sprung mass,
- q_5 = vertical displacement of tractor front unsprung mass,
- q_6 = vertical displacement of tractor leading tandem axle,
- q_7 = vertical displacement of tractor trailing tandem axle,
- q_8 = vertical displacement of trailer leading tandem axle,
- q_9 = vertical displacement of trailer trailing tandem axle,
- q_{10} = vertical velocity of tractor sprung mass,
- q_{11} = pitch angular velocity of tractor sprung mass,
- q_{12} = vertical velocity of trailer sprung mass,
- q_{13} = pitch angular velocity of trailer sprung mass,
- q_{14} = vertical velocity of tractor front unsprung mass,
- q_{15} = vertical velocity of tractor leading tandem axle,
- q_{16} = vertical velocity of tractor trailing tandem axle,
- q_{17} = vertical velocity of trailer leading tandem axle,
- q_{18} = vertical velocity of trailer trailing tandem axle,
- u_1 = elevation profile of road under tractor front wheel,



E 2034 – 99

u_2 = elevation profile of road under tractor leading rear wheel,
 u_3 = elevation profile of road under tractor trailing rear wheel,

u_4 = elevation profile of road under trailer leading wheel,
and
 u_5 = elevation profile of road under trailer trailing wheel.

ASTM International takes no position respecting the validity of any patent rights asserted in connection with any item mentioned in this standard. Users of this standard are expressly advised that determination of the validity of any such patent rights, and the risk of infringement of such rights, are entirely their own responsibility.

This standard is subject to revision at any time by the responsible technical committee and must be reviewed every five years and if not revised, either reapproved or withdrawn. Your comments are invited either for revision of this standard or for additional standards and should be addressed to ASTM International Headquarters. Your comments will receive careful consideration at a meeting of the responsible technical committee, which you may attend. If you feel that your comments have not received a fair hearing you should make your views known to the ASTM Committee on Standards, at the address shown below.

This standard is copyrighted by ASTM International, 100 Barr Harbor Drive, PO Box C700, West Conshohocken, PA 19428-2959, United States. Individual reprints (single or multiple copies) of this standard may be obtained by contacting ASTM at the above address or at 610-832-9585 (phone), 610-832-9555 (fax), or service@astm.org (e-mail); or through the ASTM website (www.astm.org).