



Standard Specification for Telecommunications and Information Exchange Between Roadside and Vehicle Systems — 5 GHz Band Dedicated Short Range Communications (DSRC) Medium Access Control (MAC) and Physical Layer (PHY) Specifications¹

This standard is issued under the fixed designation E 2213; the number immediately following the designation indicates the year of original adoption or, in the case of revision, the year of last revision. A number in parentheses indicates the year of last reapproval. A superscript epsilon (ϵ) indicates an editorial change since the last revision or reapproval.

1. Scope

1.1 This specification² describes a medium access control (MAC) and physical layer (PHY) specification for wireless connectivity using dedicated short-range communications (DSRC) services. This standard is based on and refers to IEEE Standards 802.11, *Wireless LAN Medium Access Control and Physical Layer Specifications*, and 802.11a, *Wireless LAN Medium Access Control and Physical Layer Specifications High-Speed Physical Layer in the 5 GHz Band*, with permission from the IEEE society. This specification is meant to be an extension of IEEE 802.11 technology into the high-speed vehicle environment. As presented here, this specification contains just enough information to explain the difference between IEEE 802.11 and IEEE 802.11a operating parameters required to implement a mostly high-speed data transfer service in the 5.9-GHz Intelligent Transportation Systems Radio Service (ITS-RS) Band. Potential operations within the Unlicensed National Information Infrastructure (UNII) Band are also addressed, as appropriate.

1.2 *Purpose*—The purpose of this specification is to provide wireless communications over short distances between information sources and transactions stations on the roadside and mobile radio units, between mobile units, and between portable units and mobile units. The communications generally occur over line-of-sight distances of less than 1000 m between roadside units and mostly high speed, but occasionally stopped and slow moving, vehicles or between high-speed vehicles. This specification also offers regulatory bodies a means of standardizing access to the 5.9 GHz frequency band for the purpose of interoperable communications to and between vehicles at line-of-sight distances on the roadway.

1.3 Specifically, this specification accomplishes the following:

1.3.1 Describes the functions and services required by a DSRC and IEEE 802.11 compliant device to operate in a high-speed mobile environment.

1.3.2 Refers to IEEE 802.11 MAC procedures.

1.3.3 Defines the 5.9 GHz DSRC signaling technique and interface functions that are controlled by the IEEE 802.11 MAC.

1.3.4 Permits the operation of a DSRC conformant device within a DSRC communications zone that may coexist with multiple overlapping DSRC communication zones.

1.3.5 Describes the requirements and procedures to provide privacy of user information being transferred over the wireless medium and authentication of the DSRC or IEEE 802.11 conformant devices.

2. Referenced Documents

2.1 *IEEE Standards:*

802.11 Wireless LAN Medium Access Control (MAC) and Physical Layer (PHY) Specifications³

802.11a Wireless LAN Medium Access Control (MAC) and Physical Layer (PHY) Specifications—Amendment 1: High-Speed Physical Layer in the 5 GHz Band³

2.2 *Federal Document:*

CFR 47 Title 47 on Telecommunication⁴

3. Terminology

3.1 *Definitions*—See IEEE 802.11, Clause 3, in addition to the following information:

3.1.1 *onboard unit (OBU)*—an onboard unit (OBU) is a DSRC transceiver that is normally mounted in or on a vehicle, but which in some instances may be a portable unit. An OBU can be operational while a vehicle or person is either mobile or stationary. The OBUs receive and contend for time to transmit

¹ This specification is under the jurisdiction of ASTM Committee E17 on Vehicle–Pavement Systems and is the direct responsibility of Subcommittee E17.51 on Vehicle Roadside Communication.

Current edition approved July 10, 2003. Published September 2003. Originally approved in 2002. Last previous edition approved in 2002 as E 2213 – 02¹.

² This specification is based on IEEE 802.11, 1999 Edition and IEEE 802.11a, 1999 Edition. This specification explains the DSRC parameters as an extension of the IEEE 802.11 and IEEE 802.11a documents.

³ Available from Institute of Electrical and Electronics Engineers, Inc. (IEEE), 445 Hoes Ln., P.O. Box 1331, Piscataway, NJ 08854-1331

⁴ Available from U.S. Government Printing Office Superintendent of Documents, 732 N. Capitol St., NW, Mail Stop: SDE, Washington, DC 20401.

on one or more RF channels. Except where specifically excluded, OBU operation is permitted wherever vehicle operation or human passage is permitted. The OBUs mounted in vehicles are licensed by rule and communicate with roadside units (RSUs) and other OBUs. Portable OBUs are also licensed by rule. OBU operations in the UNII Bands follow the rules in those bands.

3.1.2 *roadside unit (RSU)*—a roadside unit is a DSRC transceiver that is mounted along a road or pedestrian passage-way. An RSU may also be mounted on a vehicle or is hand-carried, but it may only operate when the vehicle or hand-carried unit is stationary. Furthermore, an RSU operating under CFR 47 Part 90 rules is restricted to the location where it is licensed to operate. However, portable or hand-held RSUs are permitted to operate on the Control Channel and Service channels where they do not interfere with a site-licensed operation. A RSU broadcasts data to OBUs or exchanges data with OBUs in its communications zone. An RSU also provides channel assignments and operating instructions to OBUs in its communications zone, when required.

3.1.3 *private (application)*—implementation of a DSRC service to transfer data to and from individual or business-owned devices to enable business or user data transactions or to improve the efficiency of business data transactions.

3.1.4 *public safety (application)*—implementation of a DSRC service by a government or government sponsored activity as defined in CFR 47 USC section 309(j).

3.2 *Acronyms*—See IEEE 802.11, Clause 4, in addition to the following information:

- 3.2.1 *BPSK*—binary phase shift keying
- 3.2.2 *C-MPDU*—coded MPDU
- 3.2.3 *DSRC*—dedicated short-range communications
- 3.2.4 *FFT*—Fast Fourier Transform
- 3.2.5 *GI*—guard interval
- 3.2.6 *IFFT*—inverse Fast Fourier Transform
- 3.2.7 *MLME*—MAC sublayer management entity
- 3.2.8 *OBU*—onboard unit
- 3.2.9 *OFDM*—orthogonal frequency division multiplexing
- 3.2.10 *PER*—packet error rate
- 3.2.11 *PLME*—PHY management entity
- 3.2.12 *QAM*—quadrature amplitude modulation
- 3.2.13 *QPSK*—quadrature phase shift keying
- 3.2.14 *RSU*—roadside unit
- 3.2.15 *U-NII*—unlicensed national information infrastructure

4. General Description

4.1 This specification defines the Open Systems Interconnection (OSI) Layer 1, physical layer, and Layer 2, medium access control layer for DSRC equipment operating in a two-way or one-way, half-duplex, active mode. The physical layer is a special case implementation of IEEE 802.11a technology and the medium access control layer is the same as the IEEE 802.11 MAC. All references in this specification to IEEE 802.11 MAC concepts are incorporated in the DSRC implementation. This specification establishes a common framework for the physical layer in the 5.850 to 5.925 GHz ITS-RS band. This band is allocated for DSRC applications by the FCC in Title 47, Code of Federal Regulations (CFR), Part

90, Subpart M and by Industry Canada in the Spectrum Management, Radio Standard Specification, Location and Monitoring Service (5.850 to 5.925 GHz), Number TBD.

4.1.1 *General Description of the DSRC and IEEE 802.11 Architecture*—See IEEE 802.11, Clause 5.1.

4.1.1.1 *How Wireless LAN Systems are Different from Wired LAN Systems*—See IEEE 802.11, Clause 5.1.1 and sub-clauses:

4.1.1.2 *How DSRC Systems are Different from IEEE 802.11 Systems*:

(1) This specification defines a medium access control and air interface that enables accurate and valid message delivery with communication units that are primarily mounted in high-speed moving vehicles. These communications may occur with other units that are: (1) fixed along the roadside or above the roadway; (2) mounted in other high-speed moving vehicles; (3) mounted in stationary vehicles; or (4) portable or hand-held. Communications may also occur between stationary or low-speed mobile units and fixed or portable units on the roadside or off-the-road, in private or public areas. However, most IEEE 802.11 systems implement communications between stationary units or mobile units moving at low speeds. High-speeds are considered those achieved by the general public and emergency vehicles on North American highways. Low-speeds are considered as walking to running paces.

(2) DSRC devices must be capable of transferring messages to and from vehicles at speeds of 85 mph with a Packet Error Rate (PER) of less than 10 % for PSDU lengths of 1000 bytes and to and from vehicles at speeds of 120 mph with a PER of less than 10 % for PSDU lengths of 64 bytes.

(3) As explained in the definitions, in-vehicle communications units are called on-board units (OBUs). Communication units fixed along the roadside, over the road on gantries or poles, or off the road in private or public areas are called roadside units (RSUs). The DSRC RSUs may function as stations or as access points (APs) and DSRC OBUs only have functions consistent with those of stations (STAs). The common function between all RSUs is that these stationary units control access to the RF medium for OBUs in their communication zone or relinquish control to broadcast data only.

(4) In order to accommodate the more dynamic environment with essentially the same radio technology and provide priority to public safety communications, DSRC uses a different channel access strategy than IEEE 802.11 units and employs additional operating rules. This additional System Management strategy is described primarily in the IEEE Control Channel and Service Channel Standard (under development) Number TBD.

(5) The essence of this strategy is the identification of a control channel and service channels, a system of priority access, and mandatory service channel data transfer time limits while in motion.

(6) DSRC uses a unique Ad Hoc mode. The DSRC Ad Hoc mode is used on all DSRC channels as the default mode of operation. However, it is the only mode of operation on the control channel. In this mode, the BSSID is all zeros and there is no distributed beaconing mechanism. An OBU nominally listens on the control channel for messages or application announcements and a data exchange channel assignment, but

does not scan. The IEEE 802.11-1999 management frames are received and acknowledged but not acted upon in the DSRC Ad Hoc mode.

(7) RF power, sensitivity, and antenna pattern are intended to be referenced to a standard location on the vehicle. This standard location is intended to be the front bumper of a passenger vehicle or the equivalent on a commercial vehicle. Annex A3 describes the power and antenna calibration factors.

4.2 *Components of the IEEE 802.11 Architecture*—See IEEE 802.11, Clause 5.2.

4.3 *Logical Service Interfaces*—See IEEE 802.11, Clause 5.3.

4.4 *Overview of the Services*—See IEEE 802.11, Clause 5.4.

4.5 *Relationships Between Services*—See IEEE 802.11, Clause 5.5.

4.6 *Difference Between ESS and IBSS LANs*—See IEEE 802.11, Clause 5.6.

4.7 *Message Information Contents that Support the Services*—See IEEE 802.11, Clause 5.7.

4.8 *Reference Model*—See IEEE 802.11, Clause 5.8.

4.9 *Implementation of DSRC Using IEEE 802.11 Architecture Components*:

4.9.1 The DSRC communications are conducted either between RSUs and OBUs, as shown in Figs. 1 and 2, or only

this standard in addition to the requirements for a DSRC Ad Hoc mode of operation.

5.2.1 *DSRC Ad Hoc Mode*—DSRC devices shall implement a DSRC Ad Hoc mode of operation. In this mode, only the Control, Data, and Management type fields described below are used. (See IEEE 802.11, Table 1). Within the Control type field, only the RTS, CTS, and ACK subtypes are used. Within the Data type field, only the basic data subtype is used. RTS and CTS shall not be used in the control channel.

5.3 *Authentication and Privacy*—See IEEE 802.11, Clause 8.

5.4 *MAC Sublayer Functional Description*—See IEEE 802.11, Clause 9. All of the specifications of IEEE 802.11, Clause 9, are incorporated in this standard in addition to the requirements for a DSRC Ad Hoc mode of operation.

5.4.1 *DSRC Ad Hoc Mode*—In the DSRC Ad Hoc mode of operation, only three Frame Exchange Sequences, “Data,” “Mgmt,” and “{RTS - CTS-}[Frag - ACK -] Last - ACK” are used (See IEEE 802.11, Table 21).

5.5 *Multirate Support*—For the 5 GHz PHY, the time required to transmit a frame for use in the Duration/ID field is determined using the PLME-TXTIME.request primitive and the PLME-TXTIME.confirm primitive. The calculation method of TXTIME duration is defined in IEEE 802.11a,

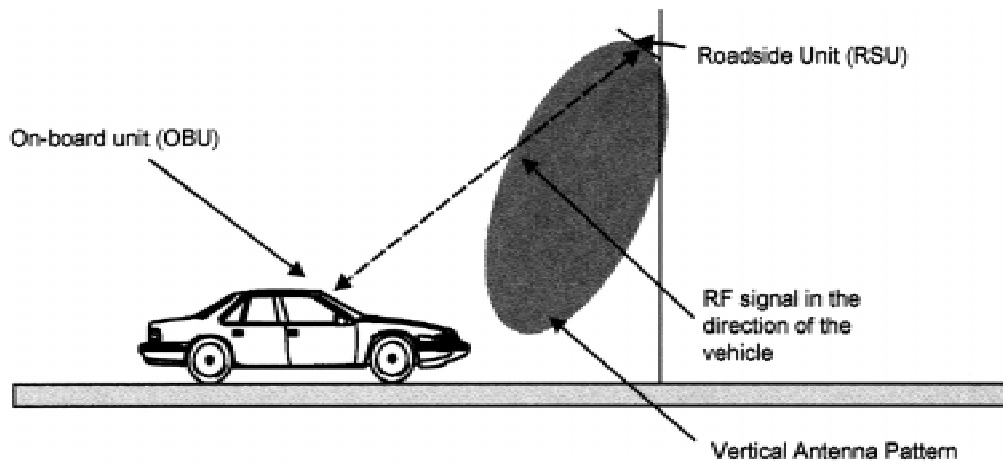

FIG. 1 RSU Communicating With an OBU

between OBUs, as shown in Fig. 3.

4.9.2 The DSRC communications may be routed from or into wide area networks by portals from RSUs, as shown in Fig. 4.

4.9.3 The DSRC communications may be routed between wide area networks and in-vehicle networks by portals from OBUs and RSUs, as shown in Figs. 5-7.

4.9.4 DSRC devices shall implement a DSRC Ad-Hoc mode and initialize to the settings defined in Annex A2 to operate in the ITS-RS band.

5. MAC Operation (IEEE 802.11 and IEEE 802.11a Referenced Paragraphs)

5.1 *MAC Service Definition*—See IEEE 802.11, Clause 6.

5.2 *Frame Formats*—See IEEE 802.11, Clause 7. All of the specifications of IEEE 802.11, Clause 7, are incorporated in

Clause 17.4.3.

6. Layer Management

6.1 See IEEE 802.11, Clause 10.

6.2 Add to IEEE 802.11, Clause 10: Remove the references to aMPDUDurationFactor from 10.4.3.1.

6.3 Add to IEEE 802.11, Clause 10:

6.3.1 *PLME-TXTIME.request*:

6.3.1.1 *Function*—This primitive is a request for the PHY to calculate the time that will be required to transmit a PPDU containing a specified length MPDU, and using a specified format, data rate, and signaling onto the wireless medium.

6.3.1.2 *Semantics of the Service Primitive*—This primitive provides the following parameters: PLME-TXTIME.request(TXVECTOR). The TXVECTOR represents a list of parameters that the MAC sublayer provides to the local

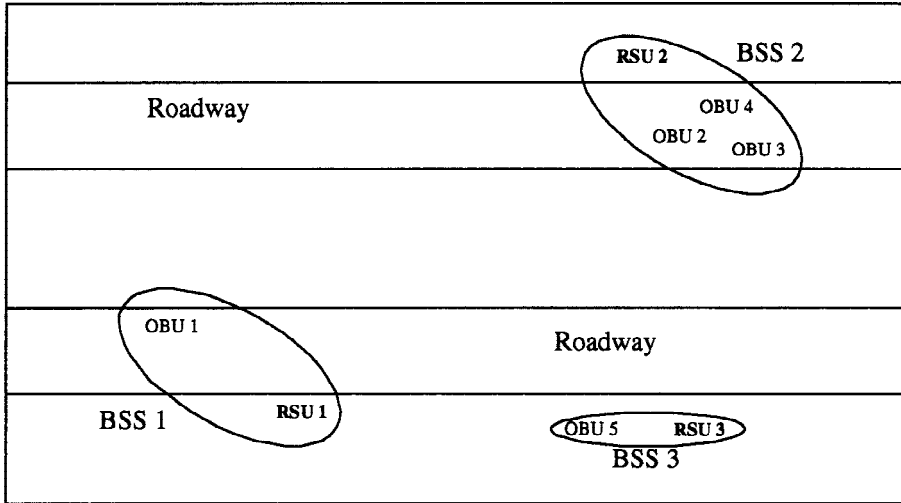

FIG. 2 Basic Service Sets With RSUs and OBUs

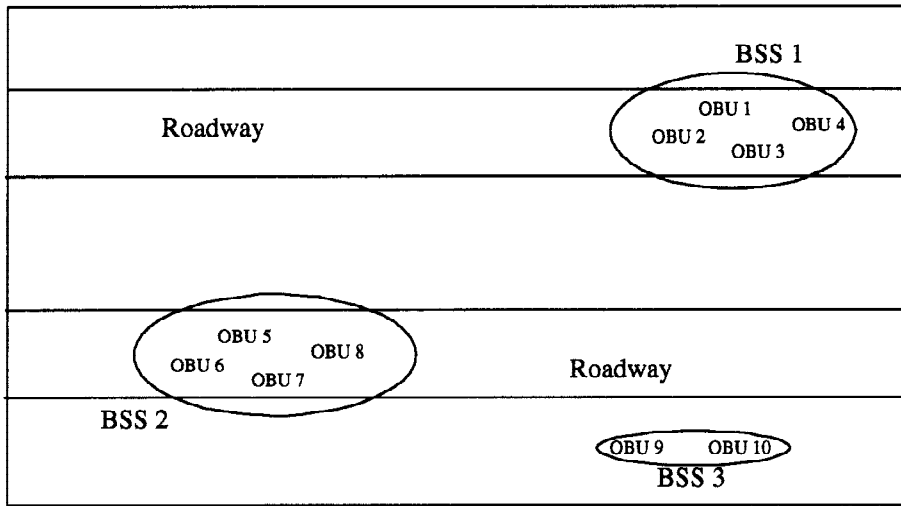

FIG. 3 Basic Service Sets With OBUs Only

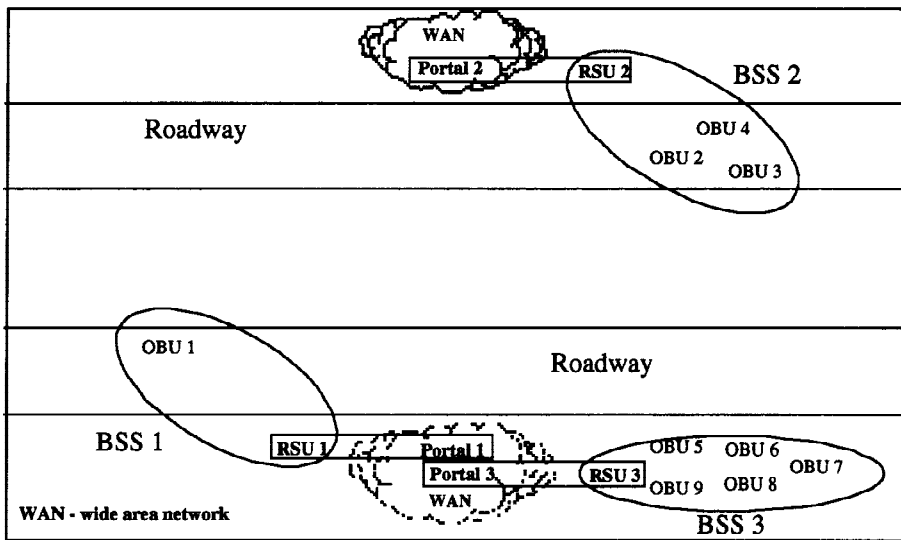

FIG. 4 Connecting OBUs to Wide-Area Networks

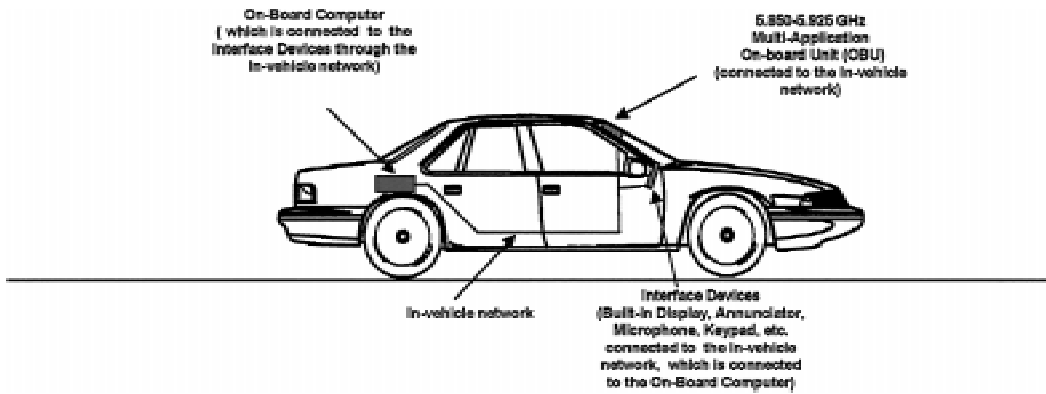

FIG. 5 Connecting an OBU to an In-vehicle Network

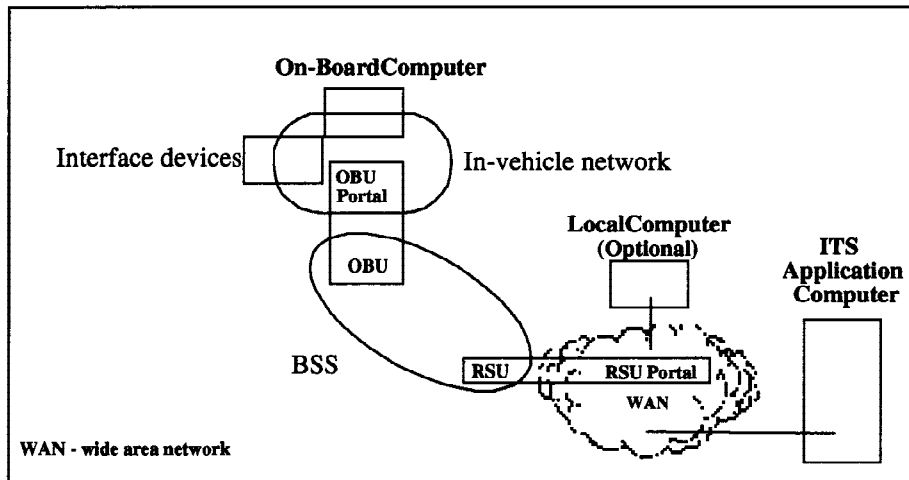

FIG. 6 BSS Connects On-board Computer Through the WAN to the ITS Application

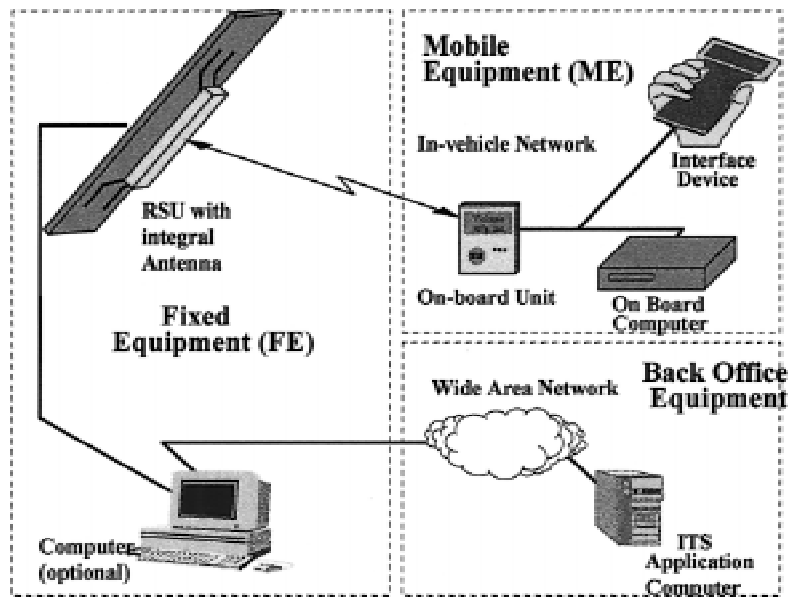

FIG. 7 Connecting a Remote ITS Application to On-board Systems

PHY entity in order to transmit an MPDU, as further described in IEEE 802.11 Clauses 12.3.4.4 and 17.4 (which defines the local PHY entity).

6.3.1.3 *When Generated*—This primitive is issued by the MAC sublayer to the PHY entity whenever the MAC sublayer needs to determine the time required to transmit a particular MPDU.

6.3.1.4 *Effect of Receipt*—The effect of receipt of this primitive by the PHY entity shall be to generate a PHY-TXTIME.confirm primitive that conveys the required transmission time.

6.3.2 *PLME-TXTIME.confirm*:

6.3.2.1 *Function*—This primitive provides the time that will be required to transmit the PPDU described in the corresponding PLME-TXTIME.request.

6.3.2.2 *Semantics of the Service Primitive*—This primitive provides the following parameters: PLME-TXTIME.confirm(TXTIME). The TXTIME represents the time in microseconds required to transmit the PPDU described in the corresponding PLME-TXTIME.request. If the calculated time includes a fractional microsecond, the TXTIME value is rounded up to the next higher integer.

6.3.2.3 *When Generated*—This primitive is issued by the local PHY entity in response to a PLME-TXTIME.request.

6.3.2.4 *Effect of Receipt*—The receipt of this primitive provides the MAC sublayer with the PPDU transmission time.

6.4 *MAC Sublayer Management Entity*—See IEEE 802.11, Clause 11. All of the specifications of IEEE 802.11, Clause 11, are incorporated in this standard in addition to the requirements for a DSRC Ad Hoc mode of operation and the capability to generate a dynamic MAC address.

6.4.1 *DSRC Ad Hoc Mode*—In the DSRC Ad Hoc mode of operation the BSSID shall be all zeros, which is a change to the function described in IEEE 802.11, Clause 11.1. There shall be no distributed beaconing mechanism, which is a change to IEEE 802.11, Clause 11.1.2. DSRC devices do not implement the 802.11 scanning function, which is a change to IEEE 802.11, Clause 11.1.3. DSRC devices use the default channel of operation as defined by the Management primitives, in IEEE 802.11, Clause 11. In addition, the management frames are received and acknowledged but not acted upon.

6.4.2 *Dynamic MAC Address*—DSRC OBU devices shall implement a mechanism to dynamically generate a random MAC address to be used to control DSRC network access and confidentiality. The MAC address shall be a randomly generated number that minimizes the probability of OBUs generating the same number, even when those OBUs are subjected to the same initial conditions. The new random MAC address shall be generated upon start-up of the device.

6.4.2.1 In the 48 bit MAC address, the individual/group bit shall be set as needed and the Global/Local bit shall be set to local. The remaining 46 bits shall receive the randomized address. The random algorithm shall generate an uncorrelated value. If an OBU ever receives a frame with its own address as the source address, the receiving OBU selects a new MAC address. Duplicate address detection is done during association. If a station that is already associated attempts to reassociate, assume it is a duplicate. A “regenerate MAC address” command shall be sent.

6.4.2.2 One of the following FIPS or ANSI random number generators shall be used: FIPS 186 (DSS) Appendix 3.1 or Appendix 3.2; ANSI X9.31 Appendix A.2.4; or ANSI X9.62-1998 Annex A.4.

7. IEEE 802.11a Section 12 Updates for DSRC

The following paragraphs define the changes and additions to Clause 12 of IEEE 802.11 to describe the standard as it applies to a DSRC device.

7.1 *DSRC Physical Layer Service Specifications*—See IEEE 802.11, Clause 12. All of the specifications of IEEE 802.11, Clause 12, are incorporated in this standard with the following requirements added for a higher resolution for RSSI measurements and the generation of a random MAC address.

7.1.1 *HRRSSI PHY-SAP Sublayer-to-Sublayer Service Primitives*—PHY-HRRSSI Request and Confirm service primitives shall be added to those identified in IEEE 802.11, Table 25.

7.1.2 *PHY-HRRSSI.request*:

7.1.2.1 *Function*—This primitive is a request by the MAC sublayer to the local PHY entity to lock the AGC and get ready for high resolution RSSI mode.

7.1.2.2 *Semantics of the Service Primitive*—The primitive provides the following parameters: PHY-HRRSSI.request (SWITCH). SWITCH is a parameter that has two values: ON and OFF. When the value is ON, the MAC sublayer requests the PHY entity to enter the high resolution RSSI mode and when the value is OFF, the MAC sublayer request the PHY entity to exit the high resolution RSSI mode.

7.1.2.3 *When Generated*—This primitive will be issued by the MAC sublayer to the PHY entity whenever the MAC sublayer needs to enter or exit the high resolution RSSI mode.

7.1.2.4 *Effect of Receipt*—The effect of receipt of this primitive by the PHY entity will be to lock the AGC and enter the high resolution RSSI mode or unlock the AGC and exit the high resolution RSSI mode.

7.1.3 *PHY-HRRSSI.confirm*:

7.1.3.1 *Function*—This primitive is issued by the PHY sublayer to the local MAC entity to confirm the entering or exiting of the high resolution RSSI mode.

7.1.3.2 *Semantics of the Service Primitive*—The semantics of the primitive are as follows: PHY-HRRSSI.confirm. There are no parameters associated with this primitive.

7.1.3.3 *When Generated*—This primitive will be issued by the PHY sublayer to the MAC entity whenever the PHY has received a PHY-HRRSSI.request from the MAC entity and is ready for high resolution RSSI measurement or out of the high resolution RSSI mode.

7.1.3.4 *Effect of Receipt*—The receipt of this primitive by the MAC entity will cause the MAC to indicate the received RSSI as a high resolution RSSI or as a normal resolution RSSI.

7.1.4 *RANDOMMAC PHY-SAP Sublayer-to-Sublayer Service Primitives*—PHY-RANDOMMAC generation of a random MAC address request service primitive shall be added to those identified in IEEE 802.11, Table 25.

7.1.5 *PHY-RANDOMMAC.request*:

7.1.5.1 *Function*—This primitive is a request by the MAC sublayer to the local PHY entity to generate a random MAC address using an FIPS or ANSI random number generator.

7.1.5.2 *Semantics of the Service Primitive*—The primitive provides the following parameters: PHY-RANDOMMAC.request.

TABLE 1 TXVECTOR Parameters^A

Parameter	Associate Primitive	Value
LENGTH	PHY- TXSTART.request (TXVECTOR)	1-4095
DATARATE	PHY- TXSTART.request (TXVECTOR)	3, 4.5, 6, 9, 12, 18, 24, and 27 (Support of 3, 6, and 12 data rates is mandatory.)
SERVICE	PHY- TXSTART.request (TXVECTOR)	scrambler initialization; 7 null bits + 9 reserved null bits
TXPWR_LEVEL	PHY- TXSTART.request (TXVECTOR)	1-64

^A From IEEE 802.11a. Copyright 1999 IEEE. All rights reserved.

7.1.5.3 *When Generated*—This primitive shall be issued by the MAC sublayer to the PHY entity during start-up or whenever the MAC sublayer requests that the PHY entity regenerate a MAC address.

7.1.5.4 *Effect of Receipt*—The effect of receipt of this primitive by the PHY entity will be to generate an uncorrelated random MAC address.

8. IEEE 802.11a Section 17 Updates for DSRC

The following paragraphs define the changes in Clause 17 of IEEE 802.11a as modified to describe DSRC device implementations. IEEE 802.11, the IEEE 802.11a Supplement, and the additions or modifications that follow fully describe the standard as it applies to a DSRC device.

8.1 *Introduction—DSRC PHY Specification for the 5 GHz Band*—This clause specifies the PHY entity for an orthogonal frequency division multiplexing (OFDM) system and additions that have to be made to the base standard in order to accommodate the OFDM PHY. This DSRC radio frequency system is initially intended for the 5.850-5.925 GHz-licensed ITS Radio Services Band, as regulated in the United States by the Code of Federal Regulations, Title 47, Part 90. The OFDM system provides DSRC with data payload communication capabilities of 3, 4.5, 6, 9, 12, 18, 24, and 27 Mbit/s. In addition data payload capabilities of 6, 9, 12, 18, 24, 36, 48, and 54 Mbit/s can be supported in optional channel combinations. The support of transmitting and receiving at data rates of 3, 6, and 12 Mbit/s is mandatory. The system uses 52 subcarriers, modulated using binary or quadrature phase shift keying (BPSK/QPSK), 16-quadrature amplitude modulation (QAM), or 64-QAM. Forward error correction coding (convolution coding) is used with a coding rate of 1/2, 2/3, or 3/4.

8.2 *TXVECTOR Parameters*—The parameters in Table 1⁵ are defined as part of the TXVECTOR parameter list in the PHY- TXSTART.request service primitive.

⁵ This table is reprinted with permission from IEEE 802.11a “IEEE Standard for Information Technology—Telecommunications and Information Exchange Between Systems—Local and Metropolitan Area Networks—Specific Requirements—Part 11: Wireless LAN Medium Access Control (MAC) and Physical Layer (PHY) Specifications—Amendment 1: High-Speed Physical Layer in the 5 GHz Band,” Copyright 1999, by IEEE. The IEEE disclaims any responsibility or liability resulting from the placement and use in the described manner.

8.2.1 *TXVECTOR DATARATE*—The DATARATE parameter describes the bit rate at which the PLCP shall transmit the PSDU. Its value can be any of the rates defined in Table 1.⁵ Data rates of 3, 6, and 12 Mbps shall be supported. Other rates may also be supported.

8.3 *RXVECTOR Parameters*—The parameters listed in Table 2⁵ are defined as part of the RXVECTOR parameter list in the PHY- RXSTART.indicate service primitive.

8.3.1 *RXVECTOR RSSI*—The allowed values for the receive signal strength indicator (RSSI) parameter are in the range from 0 to RSSI maximum. This parameter is a measure by the PHY sublayer of the energy observed at the antenna used to receive the current PPDU. The RSSI shall be measured during the reception of the PLCP preamble. The RSSI is intended to be used in a relative manner, and it shall be a monotonically increasing function of the received power. Subsequent to a period of no less than 2 ms after an alert signal, the minimum RSSI resolution should be less than or equal to 0.2 dB and must be accurate to ± 1 dB across the entire operating temperature range within -60 to -30 dBm of the receiving signal range.

8.3.2 *DATARATE*—DATARATE shall represent the data rate at which the current PPDU was received. The allowed values of the DATARATE are 3, 4.5, 6, 9, 12, 18, 24, or 27 Mbps.

8.4 *RATE-dependent Parameters*—The modulation parameters dependent on the data rate used shall be set according to Table 3.⁵

8.4.1 *Timing-Related Parameters*—Table 4⁵ is the list of timing parameters associated with the OFDM PLCP.

8.4.2 *Discrete Time Implementation Considerations*—See IEEE 802.11a, Clause 17.3.2.5.

8.5 *PLCP Preamble (SYNC)*:

8.5.1 The PLCP preamble field is used for synchronization. It consists of 10 short symbols and two long symbols that are shown in Fig. 8 and described as follows. Fig. 8 shows the OFDM training structure (PLCP preamble), where t_1 to t_{10} denote short training symbols and T_1 and T_2 denote long training symbols. The PLCP preamble is followed by the SIGNAL field and DATA. The total training length is 32 μ s. The dashed boundaries in Fig. 8 denote repetitions due to the periodicity of the inverse Fourier transform.

8.5.2 A short OFDM training symbol consists of 12 subcarriers, which are modulated by the elements of the sequence S , given as follows:

TABLE 2 RXVECTOR Parameters^A

Parameter	Associate Primitive	Value
LENGTH	PHY- RXSTART.indicate	1-4095
RSSI	PHY- RXSTART.indicate (RXVECTOR)	0-RSSI maximum
DATARATE	PHY- RXSTART.request (RXVECTOR)	3, 4.5, 6, 9, 12, 18, 24, and 27
SERVICE	PHY- RXSTART.request (RXVECTOR)	null

^A From IEEE 802.11a. Copyright 1999 IEEE. All rights reserved.

TABLE 3 Rate-dependent Parameters^A

Data Rate, Mbits/s	Modulation	Coding Rate, R	Coded Bits per Subcarrier, N _{BPSC}	Coded Bits per OFDM Symbol, N _{CBPS}	Data Bits per OFDM Symbol, N _{DBPS}
3	BPSK	1/2	1	48	24
4.5	BPSK	3/4	1	48	36
6	QPSK	1/2	2	96	48
9	QPSK	3/4	2	96	72
12	16-QAM	1/2	4	192	96
18	16-QAM	3/4	4	192	144
24	64-QAM	2/3	6	288	192
27	64-QAM	3/4	6	288	216

^A From IEEE 802.11a. Copyright 1999 IEEE. All rights reserved.

TABLE 4 Timing-related Parameters^A

Parameter	Value
N _{SD} : number of data subcarriers	48
N _{SP} : number of pilot subcarriers	4
N _{ST} : number of subcarriers, total	52 (N _{SD} + N _{SP})
Δ _F : subcarrier frequency spacing	156.25 kHz (=10 MHz/64)
T _{FFT} : IFFT/FFT period	6.4 μs (1/Δ _F)
T _{PREAMBLE} : PLCP preamble duration	32 μs (T _{SHORT} + T _{LONG})
T _{SIGNAL} : duration of the SIGNAL BPSK-OFDM symbol	8 μs (T _{GI} + T _{FFT})
T _{GI} : GI duration	1.6 μs (T _{FFT} /4)
T _{GI2} : training symbol GI duration	3.2 μs (T _{FFT} /2)
T _{SYM} : symbol interval	8 μs (T _{GI} + T _{FFT})
T _{SHORT} : short training sequence duration	16 μs (10 × T _{FFT} /4)
T _{LONG} : long training sequence duration	16 μs (T _{GI2} + 2 × T _{FFT})

^A From IEEE 802.11a. Copyright 1999 IEEE. All rights reserved.

$$L_{-26, 26} = \{1, 1, -1, -1, 1, 1, -1, 1, -1, 1, 1, 1, 1, 1, -1, -1, 1, 1, -1, 1, 1, 1, 0, 1, -1, -1, 1, 1, -1, 1, -1, -1, -1, -1, -1, 1, 1, -1, -1, 1, -1, 1, 1, 1, 1\}$$

A long OFDM training symbol shall be generated according to the following equation:

$$r_{LONG}(t) = w_{TLONG}(t) \sum_{k=N_{ST}/2}^{N_{ST}/2} L_k \exp(j2\pi k \Delta_F (t - T_{GI2}))$$

where:

$$T_{GI2} = 3.2 \mu s.$$

Two periods of the long sequence are transmitted for improved channel estimation accuracy, yielding $T_{LONG} = 3.2 + 2*6.4 = 16 \mu s$. An illustration of the long training sequence

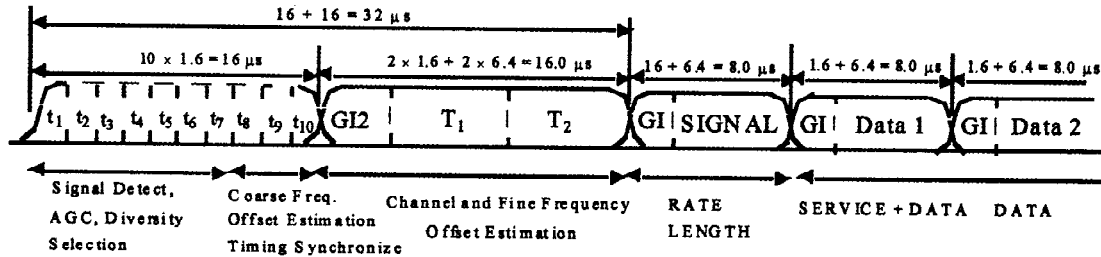

FIG. 8 OFDM Training Structure

$$S_{-26, 26} = \sqrt{(13/6)} \times \{0, 0, 1+j, 0, 0, 0, -1-j, 0, 0, 0, 1+j, 0, 0, 0, -1-j, 0, 0, 0, 0, 0, 0, 0, 0, 0, 0, -1-j, 0, 0, 0, -1-j, 0, 0, 0, 1+j, 0, 0, 0, 1+j, 0, 0, 0, 1+j, 0, 0\}$$

The multiplication by a factor of $\sqrt{(13/6)}$ is in order to normalize the average power of the resulting OFDM symbol, which utilizes 12 out of 52 subcarriers.

8.5.2.1 The signal shall be generated according to the following equation:

$$r_{SHORT}(t) = w_{TSHORT}(t) \sum_{k=N_{ST}/2}^{N_{ST}/2} S_k \exp(j2\pi k \Delta_F t)$$

The fact that only spectral lines of $S_{-26;26}$ with indices that are a multiple of 4 have nonzero amplitude results in a periodicity of $T_{FFT}/4 = 1.6 \mu s$. The interval T_{SHORT} is equal to ten 1.6 μs periods (that is, 16 μs). Generation of the short training sequence is illustrated in IEEE 802.11a, Annex G (G.3.1, Table G.2).

8.5.2.2 A long OFDM training symbol consists of 53 subcarriers (including a zero value at dc), which are modulated by the elements of the sequence L , given as follows:

generation is given in IEEE 802.11a, Annex G (G.3.2, Table G.5). The sections of short repetitions and long repetitions shall be concatenated to form the following preamble:

$$r_{PREMABLE}(t) = r_{SHORT}(t) + r_{LONG}(t - T_{SHORT})$$

8.6 *Signal Field (SIGNAL)*—The OFDM training symbols shall be followed by the SIGNAL field, which contains the RATE and the LENGTH fields of the TXVECTOR. The RATE field conveys information about the type of modulation and the coding rate as used in the rest of the packet. The encoding of the SIGNAL single OFDM symbol shall be performed with BPSK modulation of the subcarriers and using convolutional coding at $R = 1/2$. The encoding procedure, which includes convolutional encoding, interleaving, modulation mapping processes, pilot insertion, and OFDM modulation, is in accordance with IEEE 802.11a, sections 17.3.5.5, 17.3.5.6, and 17.3.5.8, as used for transmission of data at a 3-Mbit/s rate. The contents of the SIGNAL field are not scrambled.

8.6.1 The SIGNAL field shall be composed of 24 bits, as illustrated in Fig. 9. The four bits, 0 to 3, shall encode the

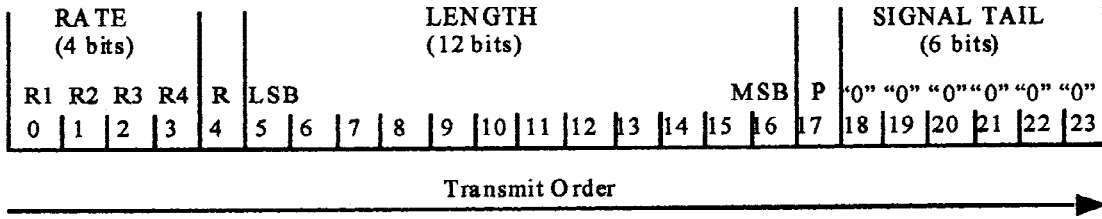

FIG. 9 SIGNAL Field Bit Assignment

RATE. Bit 4 shall be reserved for future use. Bits 5-16 shall encode the LENGTH field of the TXVECTOR, with the least significant bit (LSB) being transmitted first. The process of generating the SIGNAL OFDM symbol is illustrated in IEEE 802.11, Annex G (G.4).

8.6.1.1 *Data Rate (RATE)*—The bits R1-R4 shall be set, dependent on RATE, according to the values in Table 5.⁵

8.7 *PLCP Data Modulation and Modulation Rate Change*—The PLCP preamble shall be transmitted using an OFDM modulated fixed waveform. The SIGNAL field, BPSK-OFDM modulated at 3 Mbit/s, shall indicate the modulation and coding rate that shall be used to transmit the MPDU. The transmitter (receiver) shall initiate the modulation (demodulation) constellation and the coding rate according to the RATE indicated in the SIGNAL field. The MPDU transmission rate shall be set by the DATARATE parameter in the TXVECTOR, issued with the PHY-TXSTART.request primitive described in 8.2.

8.8 *PMD Operating Specifications (General)*—Paragraphs 8.8.1-8.8.6 provide general specifications for the BPSK OFDM, QPSK OFDM, 16-QAM OFDM, and 64-QAM OFDM PMD sublayers. These specifications apply to both the receive and transmit functions as well as the general operation of the OFDM PHY.

8.8.1 *Outline Description*—The general block diagram of the transmitter and receiver for the OFDM PHY is shown in Fig. 10. Major specifications for the OFDM PHY are listed in Table 6.⁵

8.8.2 *Regulatory Requirements:*

8.8.2.1 The DSRC operations implemented in accordance with this specification are subject to equipment certification and operating requirements established by regional and national regulatory administrations. The PMD specification establishes minimum technical requirements for interoperability, based upon established regulations at the time this specification was issued. These regulations are subject to revision or may be superseded. Requirements that are subject to local geographic regulations are annotated within the PMD specification. Regu-

latory requirements that do not affect interoperability are not addressed in this specification. Implementers are referred to the regulatory sources in Table 7⁵ for further information. Operation in countries within defined regulatory domains may be subject to additional or alternative national regulations.

8.8.2.2 The documents listed in Table 7⁵ specify the current regulatory requirements for various geographic areas at the time that this specification was developed. They are provided for information only and are subject to change or revision at any time.

8.8.3 *Operating Channel Frequencies:*

8.8.3.1 *Operating Frequency Range:*

(1) The OFDM PHY shall operate in the 5 GHz band, as allocated by a regulatory body in its operational region. Spectrum allocation in the 5 GHz band is subject to authorities responsible for geographic-specific regulatory domains (for example, global, regional, and national). The particular channelization to be used for this specification is dependent on such allocation, as well as the associated regulations for use of the allocations. These regulations are subject to revision or may be superseded. In the United States, the FCC is the agency responsible for the allocation of the 5 GHz U-NII and ITS Radio Service Bands.

(2) In some regulatory domains, several frequency bands may be available for OFDM PHY-based wireless LANs. These bands may be contiguous or not, and different regulatory limits may be applicable. A compliant OFDM PHY shall support at least one frequency band in at least one regulatory domain. The support of specific regulatory domains, and bands within the domains, shall be indicated by PLME attributes dot11 RegDomainsSupported and dot11 FrequencyBandsSupported.

8.8.3.2 *Channel Numbering*—Channel center frequencies are defined at every integral multiple of 5 MHz above 5 GHz. The relationship between center frequency and channel number is given by the following equation:

$$\text{Channel center frequency} = 5000 + 5 \times n_{ch} \text{ (MHz)}$$

where:

$$n_{ch} = 0, 1, \dots, 200.$$

This definition provides a unique numbering system for all channels with 5-MHz spacing from 5 GHz to 6 GHz, as well as the flexibility to define channelization sets for all current and future regulatory domains.

8.8.3.3 *Channelization*—The set of valid operating channel numbers by regulatory domain is defined in Table 8.⁵ Fig. 11 shows the channelization scheme for this specification, which shall be used with the FCC Intelligent Transportation Systems Radio Services (ITS-RS) allocation and the Industry Canada

TABLE 5 Contents of the SIGNAL Field⁴

Rate, Mbits/s	R1-R4
3	1101
4.5	1111
6	0101
9	0111
12	1001
18	1011
24	0001
27	0011

⁴ From IEEE 802.11a. Copyright 1999 IEEE. All rights reserved.

TABLE 6 Major Parameters of the OFDM PHY^A

Information Data Rate	3, 4.5, 6, 9, 12, 18, 24, and 27 Mbit/s (3, 6, and 12 Mbit/s are Mandatory)
Modulation	BPSK OFDM QPSK OFDM 16-QAM OFDM 64-QAM OFDM
Error correcting code	K = 7 (64 states) convolutional code
Coding rate	1/2, 2/3, 3/4
Number of subcarriers	52
OFDM symbol duration	8.0 μs
Guard interval	1.6 μs ² (T _{GI})
Occupied bandwidth	8.3 MHz

^A From IEEE 802.11a. Copyright 1999 IEEE. All rights reserved.

TABLE 7 Regulatory Requirement List^A

Geographic Area	Approval Standards	Documents	Approval Authority
United States	Federal Communications Commission (FCC)	CFR47, Part 90, Subparts I and M	FCC

^A From IEEE 802.11a. Copyright 1999 IEEE. All rights reserved.

TABLE 8 Valid Operating Channel numbers by Regulatory Domain and Band^A

Regulatory Domain	Band, GHz	Operating Channel Numbers	Channel Center Frequencies, MHz
United States and Canada	ITS-RS (5.850-5.925)	172	5860
		174	5870
		175	5875
		176	5880
		178	5890
		180	5900
		181	5905
		182	5910
		184	5920

^A From IEEE 802.11a. Copyright 1999 IEEE. All rights reserved.

MAC processing delay, and CCA detect time (<8 μs). The propagation delay shall be regarded as being included in the CCA detect time.

8.8.5 *Transmit and Receive Antenna Requirements*—The transmit and receive antenna port(s) impedance shall be 50 Ω if the port is exposed. The transmit and receive antennas shall be either right hand circularly or vertically polarized. The OFDM PHY shall operate in the 5 GHz band, as allocated by a regulatory body in its operational region. The center frequency is indicated in Fig. 11. In a multiple-cell network topology, overlapping or adjacent cells, or both, using different channels can operate simultaneously.

8.8.6 *Transmit and Receive Operating Temperature Range*—Three temperature ranges for full-operation compliance to the OFDM PHY are specified. Type 1, defined as from 0 to 40°C, is designated for office environments. Type 2, defined as from -20 to 50°C, and Type 3, defined as from -30 to 70°C, are designated for industrial environments. A fourth temperature range is added for DSRC operation. Type 4, defined as from -40 to 85°C, is designated for automotive environments.

8.9 *PMD Transmit Specifications*—Paragraphs 8.9.1-8.9.7 describe the transmit specifications associated with the PMD sublayer. In general, these are specified by primitives from the PLCP. The transmit PMD entity provides the actual means by which the signals required by the PLCP primitives are imposed onto the medium.

8.9.1 *Transmit Power Levels:*

8.9.1.1 The maximum allowable Effective Isotropic Radiated Power (EIRP) in accordance with FCC regulations is 44.8

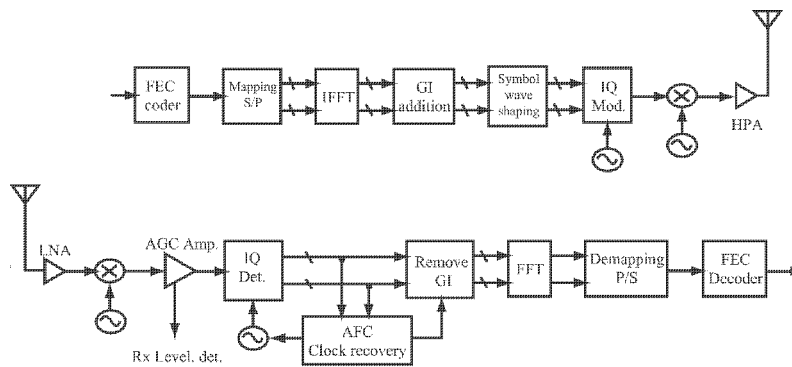

FIG. 10 Transmitter and Receiver Block Diagram for the OFDM PHY

ITS-RS allocation. The U.S. and Canadian ITS-RS Band accommodates seven channels in a total bandwidth of 75-MHz. Channels 175 and 181 are designated for DSRC equipment operating with 20-MHz bandwidth. When operating in 20 MHz channels, DSRC devices operate in compliance with the PHY layer requirements of IEEE 802.11a, except that the channel center frequencies and power limits are designated by this standard. In addition, the MAC shall continue to operate in compliance with this standard, including implementing the default DSRC Ad-hoc mode as described by this standard.

8.8.4 *Slot Time*—The slot time for the OFDM PHY shall be 16 μs, which is the sum of the RX-to-TX turnaround time,

dBm (30 W). However, most devices are expected to use much less power. The maximum output power for a device is 28.8 dBm (750 mW). A device is allowed to transmit more power to overcome cable losses to the antenna as long as the antenna input power does not exceed 28.8 dBm and the EIRP does not exceed 44.8 dBm. However, specific channels and categories of uses have additional limitations.

8.9.1.2 Public Safety and Private RSU installations operating in Channels 172, 174, 175, and 176 are used to implement small and medium range operations. RSU installation transmissions in Channels 172,174, and 176 shall not exceed 28.8 dBm antenna input power and 33 dBm EIRP. RSU installation

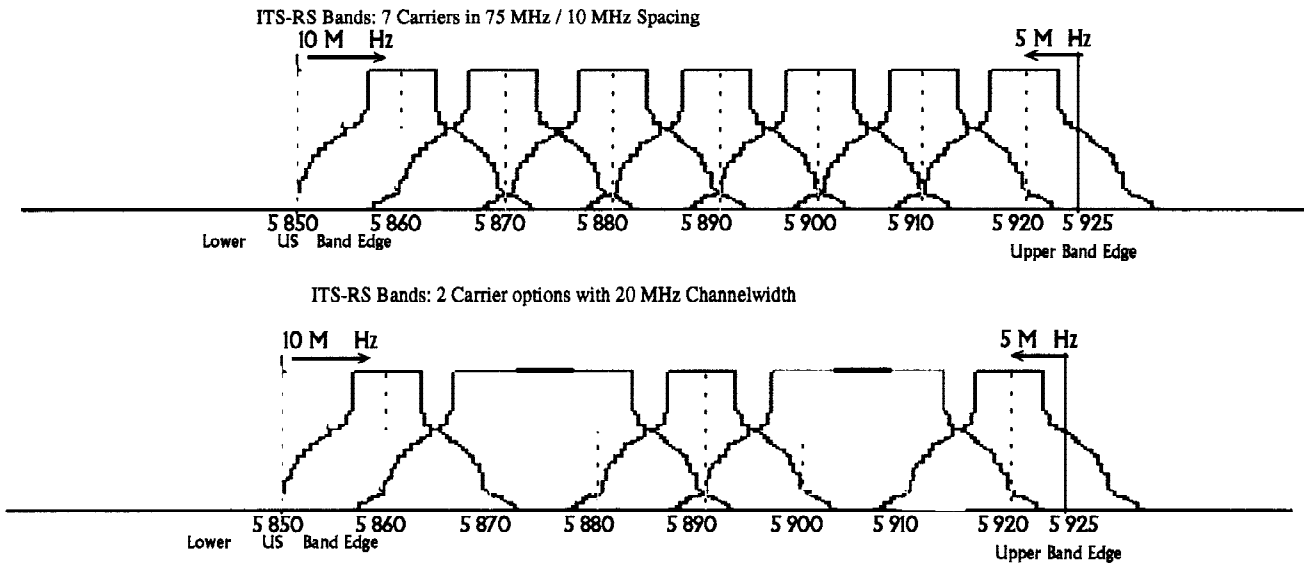

FIG. 11 OFDM PHY Frequency Channel Plan for North America

transmissions in Channel 175 shall not exceed 10 dBm antenna input power and 23 dBm EIRP.

8.9.1.3 Public Safety RSU installation transmissions in Channel 178 shall not exceed 28.8 dBm antenna input power and 44.8 dBm EIRP. Private RSU installation transmissions in Channel 178 shall not exceed 28.8 dBm antenna input power and 33 dBm EIRP.

8.9.1.4 The DSRC Channels 180, 181, and 182 are used to implement small zone operations. Public Safety and Private RSU installation in these channels shall not exceed 10 dBm antenna input power and 23 dBm EIRP. These installations shall also use an antenna with a minimum 6 dBi gain. Interfering emissions from an RSU installation in these channels shall not exceed a maximum received power level of -76 dBm at 15 m from the installation being evaluated. The received power level is measured at 1.2 m above ground level with a 0 dBi antenna.

8.9.1.5 Public Safety RSU and OBU operations in Channel 184 shall not exceed 28.8 dBm antenna input power and 40 dBm EIRP. Private RSU operations in Channel 184 shall not exceed 28.8 dBm antenna input power and 33 dBm EIRP.

8.9.1.6 Private OBU operations in Channels 172, 174, 176, 178, and 184 shall not exceed 28.8 dBm antenna input power and 33 dBm EIRP. Private OBU operations in Channel 175 shall not exceed 10 dBm antenna input power and 23 dBm EIRP. Private OBU operations in Channels 180, 181, and 182 shall not exceed 20 dBm antenna input power and 23 dBm EIRP.

8.9.1.7 Public Safety OBU operations in Channels 172, 174, and 176 shall not exceed 28.8 dBm antenna input power and 33 dBm EIRP. Public Safety OBU operations in Channel 175 shall not exceed 10 dBm antenna input power and 23 dBm EIRP.

8.9.1.8 Public Safety OBU operations in Channel 178 shall not exceed 28.8 dBm antenna input power and 44.8 dBm EIRP.

8.9.1.9 The RSUs and OBUs shall transmit only the power needed to communicate over the distance required by the application being supported.

8.9.1.10 Four classes of operation are specified for DSRC devices in the 5.850 to 5.925 GHz band and are shown in Table 9.⁵

8.9.2 Transmit Spectrum Mask:

8.9.2.1 The DSRC transmitted spectrum mask is relative to the device class of operation. The power in the transmitted spectrum for all DSRC devices shall be -25 dBm or less within 100 kHz outside all channel and band edges. This will be accomplished by attenuating the transmitted signal 100 kHz outside the channel and band edges by 55 + 10log(P) dB, where P is the total transmitted power in watts. The transmitted spectral density of the transmitted signal for all devices shall fall within the spectral mask, as detailed in Table 10.⁵ The measurements shall be made using a 100 kHz resolution bandwidth and a 30 kHz video bandwidth.

8.9.2.2 The transmitted spectral mask for class A, B, C, and D devices are shown in Figs. 12-15. In addition, all DSRC site installations shall limit the EIRP in the transmitted spectrum to -25 dBm or less in the 100 kHz at the channel edges and the band edges. Additional filtering that supplements the filtering provided by the transmitter may be needed for some antenna/transmitter combinations.

8.9.3 Spurious Transmissions—Spurious transmissions from compliant devices shall comply with national regulations.

8.9.4 Transmit Center Frequency Tolerance—The transmitted center frequency tolerance shall be ±10 ppm maximum for RSUs and ±10 ppm maximum for OBUs. The transmit center

TABLE 9 DSRC Device Classes and Transmit Power Levels^A

Device Class	Maximum Device Output Power, dBm
A	0
B	10
C	20
D	28.8 or more

^A From IEEE 802.11a. Copyright 1999 IEEE. All rights reserved.

TABLE 10 DSRC Spectrum Mask^A

NOTE—Reduction in Power Spectral Density, dB_r.

Class	± 4.5-MHz Offset	± 5.0-MHz Offset	± 5.5-MHz Offset	± 10-MHz Offset	± 15-MHz Offset
Class A	0	-10	-20	-28	-40
Class B	0	-16	-20	-28	-40
Class C	0	-26	-32	-40	-50
Class D	0	-35	-45	-55	-65

^A From IEEE 802.11a. Copyright 1999 IEEE. All rights reserved.

8.9.5 *Symbol Clock Frequency Tolerance*—The symbol clock frequency tolerance shall be ±10 ppm maximum for RSUs and ±10 ppm maximum for OBUs. The transmit center frequency and the symbol clock frequency shall be derived from the same reference oscillator.

8.9.6 *Modulation Accuracy*—Transmit modulation accuracy specifications are described as follows. The test method is described in 8.9.7.

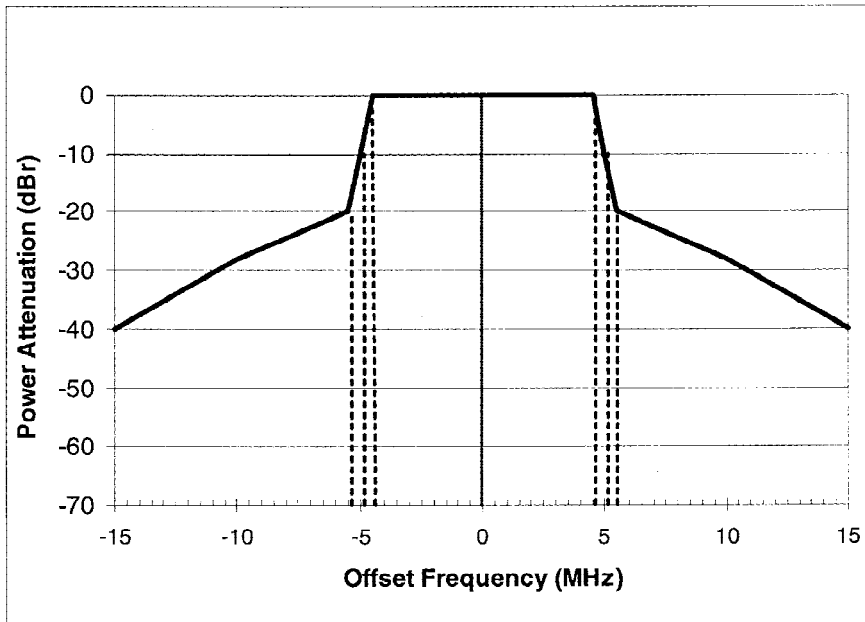

FIG. 12 Class A Transmit Spectrum Mask

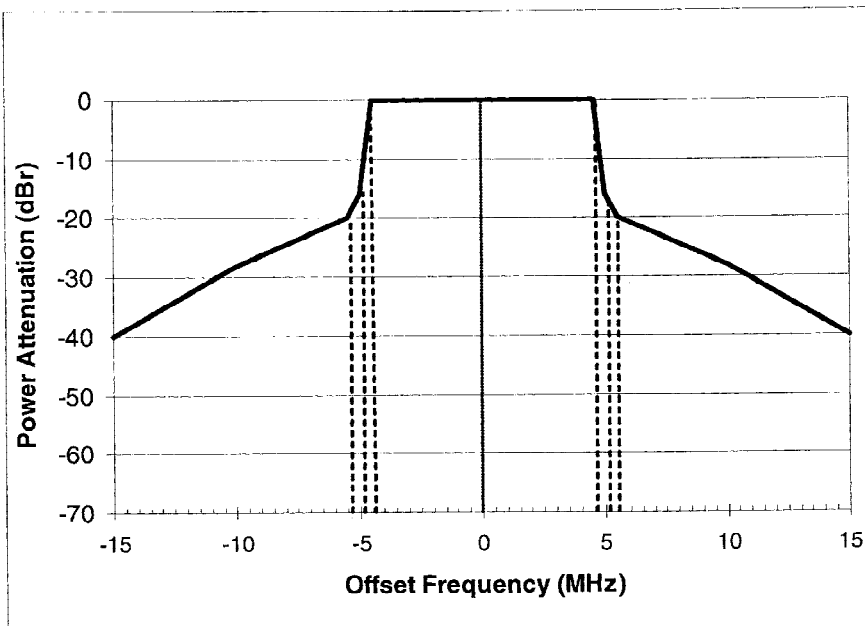

FIG. 13 Class B Transmit Spectrum Mask

frequency and the symbol clock frequency shall be derived from the same reference oscillator.

8.9.6.1 *Transmitter Center Frequency Leakage*—Certain transmitter implementations may cause leakage of the center

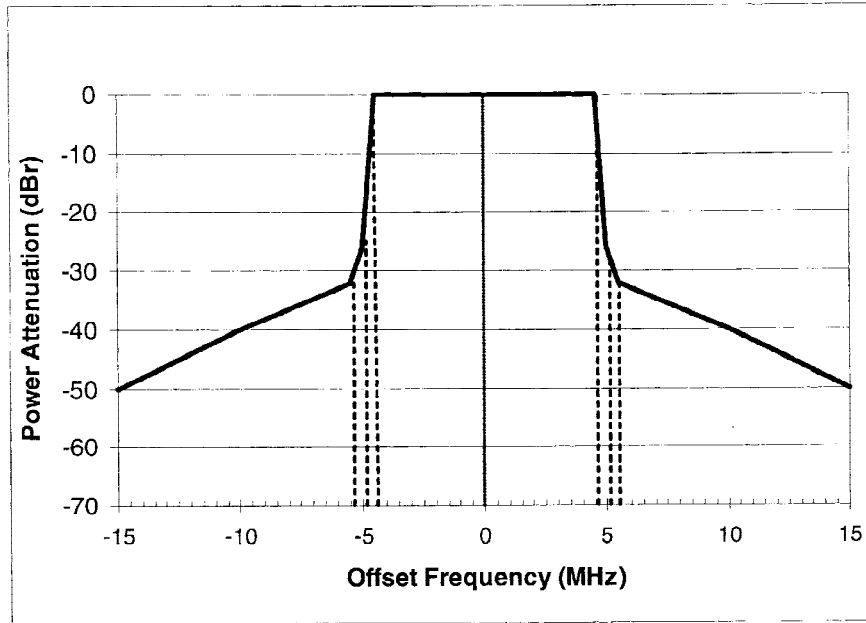

FIG. 14 Class C Transmit Spectrum Mask

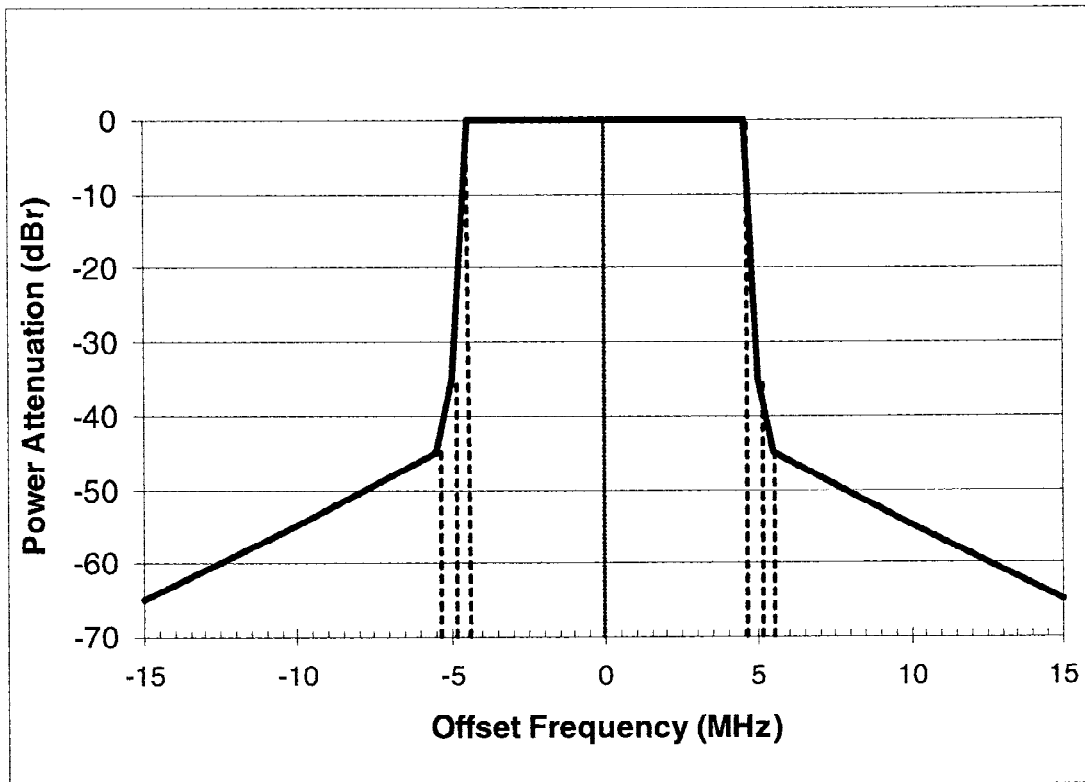

FIG. 15 Class D Transmit Spectrum Mask

frequency component. Such leakage (which manifests itself in a receiver as energy in the center frequency component) shall not exceed -15 dB relative to overall transmitted power or, equivalently, +2 dB relative to the average energy of the rest of the subcarriers. The data for this test shall be derived from the channel estimation phase.

8.9.6.2 *Transmitter Spectral Flatness*—The average energy of the constellations in each of the spectral lines -16.. -1 and +1.. +16 will deviate no more than ± 2 dB from their average energy. The average energy of the constellations in each of the spectral lines -26.. -17 and +17.. +26 will deviate no more than $\pm 2/-4$ dB from the average energy of spectral lines -16.. -1 and

+1.. +16. The data for this test shall be derived from the channel estimation step.

8.9.6.3 *Transmitter Constellation Error*—The relative constellation RMS error, averaged over subcarriers, OFDM frames, and packets, shall not exceed a data-rate dependent value according to Table 11.⁵

TABLE 11 Allowed Relative Constellation Error Versus Data Rate^A

Data Rate, Mbits/s	Relative Constellation Error, dB
3	-5
4.5	-8
6	-10
9	-13
12	-16
18	-19
24	-22
27	-25

^A From IEEE 802.11a. Copyright 1999 IEEE. All rights reserved.

8.9.7 *Transmit Modulation Accuracy Test*—The transmit modulation accuracy test shall be performed by instrumentation capable of converting the transmitted signal into a stream of complex samples at 10 Msamples/s or more, with sufficient accuracy in terms of I/Q arm amplitude and phase balance, dc offsets, phase noise, and so forth. A possible embodiment of such a setup is converting the signal to a low IF frequency with a microwave synthesizer, sampling the signal with a digital oscilloscope and decomposing it digitally into quadrature components.

8.10 *PMD Receiver Specifications:*

8.10.1 *Receiver Minimum Input Level Sensitivity*—The packet error rate (PER) shall be less than 10 % at a PSDU length of 1000 bytes for rate-dependent input levels. These levels shall be less than or equal to the numbers listed in Table 12.⁵ The minimum input levels are measured at the antenna

TABLE 12 Type 1 Receiver Performance Requirements^A

Data Rate, Mbits/s	Minimum Sensitivity, dBm	Adjacent Channel Rejection, dB	Alternate Adjacent Channel Rejection, dB
3	-85	18	34
4.5	-84	17	33
6	-82	16	32
9	-80	15	31
12	-77	13	29
18	-70	11	27
24	-69	8	24
27	-67	4	20

^A From IEEE 802.11a. Copyright 1999 IEEE. All rights reserved.

connector (NF of 10 dB and 5 dB implementation margins are assumed).

8.10.2 *Adjacent Channel Rejection*—Two categories of adjacent channel rejection capability will be allowed. They are designated as Type 1 and Type 2. The adjacent channel rejection shall be measured by setting the desired signal's strength 3 dB above the rate-dependent sensitivity specified in Table 12⁵ and Table 13⁵ and raising the power of the interfering signal, until 10 % PER is caused for a PSDU length of 1000 bytes. The power difference between the interfering and the

TABLE 13 Type 2 Receiver Performance Requirements^A

Data Rate, Mbits/s	Minimum Sensitivity, dBm	Adjacent Channel Rejection, dB	Alternate Adjacent Channel Rejection, dB
3	-85	37	44
4.5	-84	36	43
6	-82	35	42
9	-80	34	41
12	-77	32	39
18	-70	30	37
24	-69	27	34
27	-67	23	30

^A From IEEE 802.11a. Copyright 1999 IEEE. All rights reserved.

desired channel is the corresponding adjacent channel rejection. The interfering signal in the adjacent channel shall be an OFDM signal conforming to a Class A spectral mask, unsynchronized with the signal in the channel under test. For a compliant OFDM PHY, the corresponding rejection shall be no less than specified in Table 12⁵ for a Type 1 device and Table 13⁵ for a Type 2 device.

8.10.3 *Nonadjacent Channel Rejection*—The nonadjacent channel rejection shall be measured by setting the desired signal's strength 3 dB above the rate-dependent sensitivity specified in Table 12⁵ or Table 13⁵ for the type of device being tested, and raising the power of the interfering signal until a 10 % PER occurs for a PSDU length of 1000 bytes. The power difference between the interfering and the desired channel is the corresponding nonadjacent channel rejection. The interfering signal in the nonadjacent channel shall be an OFDM signal conforming to a Class A spectral mask, unsynchronized with the signal in the channel under test. For a conformed OFDM PHY, the corresponding rejection shall be no less than specified in Table 12.⁵

8.10.4 *CCA Sensitivity*—The start of a valid OFDM transmission at a receive level equal to or greater than the minimum 3 Mbit/s (−85 dBm) sensitivity shall cause CCA to indicate busy with a probability >90 % within 8 μs. If the preamble portion was missed, the receiver shall hold the carrier sense (CS) signal busy for any signal 20 dB above the minimum 3 Mbit/s sensitivity (−65 dBm).

8.10.5 *Multi-path Delay Spread*—The packet error rate (PER) shall be less than 10 % for PSDU lengths of 1000 bytes for the same signal arriving at the receiver with a time delay of 400ns rms over a period of 5 seconds for 3, 6, and 12 Mbps data rates.

8.10.6 *Doppler Spread*—The packet error rate (PER) shall be less than 10 % for PSDU length of 1000 bytes for signals arriving at the receiver with a maximum Doppler shift of ± 2100 Hz over a period of 5 seconds for 3, 6, and 12 Mbps data rates.

8.10.7 *Amplitude Variation*—The packet error rate (PER) shall be less than 10 % for PSDU length of 1000 bytes for signals arriving at the receiver with amplitude variations of 10 dB at a rate of 100 Hz over a period of 5 seconds for 3, 6, and 12 Mbps data rates. A 15 dB link margin over the minimum sensitivity shall be used for these evaluations.

8.10.8 *Rician Channel Variation*—The packet error rate (PER) shall be less than 10 % for PSDU length of 1000 bytes for signals arriving at the receiver in a simulated Rician

channel with $K = 10$ for 3, 6, and 12 Mbps data rates. A 10 dB link margin over the minimum sensitivity shall be used for these evaluations.

8.11 *OFDM PHY Management Information Base*—All OFDM PHY management information base attributes are defined in Clause 13 of IEEE 802.11, 1999 Edition, with specific values defined in Table 14.⁵ The column titled “Operational semantics” in Table 14⁵ contains two types: static and dynamic. Static MIB attributes are fixed and cannot be modified for a given PHY implementation. Dynamic MIB attributes can be modified by some management entity.

8.12 *OFDM PHY Characteristics*—The static OFDM PHY characteristics, provided through the PLME-CHARACTERISTICS service primitive, are shown in Table 15.⁵ The DSRC channel switching time (aChSwitchTime) of 2 ms has been added to Table 15. The definitions for these characteristics are given in IEEE 802.11, Clause 10.4.

8.13 *PMD_SAP Service Primitive Parameters*—Table 16⁵ shows the parameters used by one or more of the PMD_SAP service primitives.

9. DSRC Management Actions for Dynamic MAC Address

The following paragraphs define the Action field and a mechanism for specifying extended management actions for DSRC.

9.1 *DSRC Action Field*—The Action field provides a mechanism for specifying extended management actions. The format of the Action field is shown in Fig. 16. The Category field shall be set to one of the non-reserved values shown in Table 17.⁵ Action frames of a given category are referred to as <category name> Action frames. For example, frames in the “DSRC” category are called “DSRC Action frames.” If a device receives a unicast Action frame with an unrecognized Category field or some other syntactic error and the most significant bit of the Category field set to a category defined in Table 17, then the device shall return the entire Action frame to the source without change except that the most significant bit of the Category field shall be set equal to 1. The Action Details field contains the details of the action. The details of the actions allowed in each category are described in the appropriate paragraph referenced in Table 17.

9.2 *DSRC Management Actions*—Three Action frame formats are defined for DSRC Management purposes. An Action field, in the octet field immediately after the Category field, differentiates the formats. The Action field values associated with each frame format within the DSRC Category are defined in Table 18.⁵

9.2.1 *Regenerate_MAC_Address DSRC Action Frame Format*—The action body of a Regenerate_MAC_Address request DSRC Action frame may either be null, or may contain a single, 4-octet Random Value field. The values of the Activation Delay and Dialog Token fields shall be set to zero in transmitted Regenerate_MAC_Address frames and ignored in received Regenerate_MAC_Address frames. A station that

receives a unicast action frame with the DSRC Category and the Regenerate_MAC_Address action code with no action-specific octets in the action body shall invoke its random MAC address generation procedure. A station that receives a unicast action frame with the DSRC Category and the Regenerate_MAC_Address action code with the 4-octet Random Value field in the action body shall only invoke its random MAC address generation procedure if the received random value is equal to the last random value transmitted by this station in a recent Nearby_Station_response DSRC action frame. If the received random value is not equal to the most recent transmitted random value, or if the receiving station has not generated a random value for a Nearby_Station_response within the number of TU specified by the dot11AuthenticationResponseTimeout the Regenerate_MAC_Address DSRC action is ignored.

9.2.2 *Nearby_Station_request DSRC Action Frame Format*—The action body of a Nearby_Station_request DSRC Action frame format is null. No action-specific octets are required, and the value of the Activation Delay field shall be set to zero in transmitted Nearby_Station_request frames and ignored in received Nearby_Station_request frames. However, receipt of a Nearby_Station_request frame with one or more information elements in the action request body shall not be considered to constitute an invalid request, although the receiving station should ignore any such elements that may be present. The sending station shall place an arbitrary value in the Dialog Token field, and each receiving station that generates a corresponding Nearby_Station_response frame shall copy the value of the received Dialog Token into the Dialog Token field of its response. Stations should send successive Nearby_Station_request frames using distinct Dialog Token values. Nearby_Station_request frames shall be sent using a broadcast destination address. Receipt of an action frame with the DSRC Category and the Nearby_Station_request action code shall cause the receiving station to respond with a Nearby_Station_response action frame unless that station has been configured by the station management entity to ignore such requests.

9.2.3 *Nearby_Station_response DSRC Action Frame Format*—The action body of a Nearby_Station_response DSRC Action frame contains a single, 4-octet Random Value field. Each station generating a Nearby_Station_response frame shall place into this field a 32-bit pseudo-random value, generated for this frame and no other purpose from a uniform distribution over the interval [0,232-1]. The sending station shall retain this pseudo-random value, for possible matching against a subsequent Regenerate_MAC_Address frame, for at least the duration specified by the current value of dot11AuthenticationResponseTimeout. Implementers are advised that for proper operation of this protocol it is necessary for the pseudo-random sequences generated at each station to be statistically independent. The status code field shall always be transmitted as zero, and the dialog token field shall always contain the value from the Nearby_Station_request frame that caused generation of this Nearby_Station_response frame.

TABLE 14 MIB Attribute Default Values/Ranges^A

Managed Object	Default Value/Range	Operational Semantics
dot11 PHY Operation Table		
dot11 PHY type	DSRC-5. (05)	dynamic
dot11 current reg domain	implementation dependent	static
dot11 current frequency band	implementation dependent	static
dot11 temp type	implementation dependent	static
dot11 device class	implementation dependent	dynamic
dot11 ACR type	implementation dependent	dynamic
dot11 PHY Antenna Table		
dot11 current Tx antenna	implementation dependent	dynamic
dot11 diversity support	implementation dependent	static
dot11 current Rx antenna	implementation dependent	dynamic
dot11 PHY Tx Power Table		
dot11 number supported power levels	implementation dependent	static
dot11 Tx power Level 1	implementation dependent	static
dot11 Tx power Level 2	implementation dependent	static
dot11 Tx power Level 3	implementation dependent	static
dot11 Tx power Level 4	implementation dependent	static
dot11 Tx power Level 5	implementation dependent	static
dot11 Tx power Level 6	implementation dependent	static
dot11 Tx power Level 7	implementation dependent	static
dot11 Tx power Level 8	implementation dependent	static
dot11 Tx power Level 9	implementation dependent	static
dot11 Tx power Level 10	implementation dependent	static
dot11 Tx power Level 11	implementation dependent	static
dot11 Tx power Level 12	implementation dependent	static
dot11 Tx power Level 13	implementation dependent	static
dot11 Tx power Level 14	implementation dependent	static
dot11 Tx power Level 15	implementation dependent	static
dot11 Tx power Level 16	implementation dependent	static
dot11 Tx power Level 17	implementation dependent	static
dot11 Tx power Level 18	implementation dependent	static
dot11 Tx power Level 19	implementation dependent	static
dot11 Tx power Level 20	implementation dependent	static
dot11 Tx power Level 21	implementation dependent	static
dot11 Tx power Level 22	implementation dependent	static
dot11 Tx power Level 23	implementation dependent	static
dot11 Tx power Level 24	implementation dependent	static
dot11 Tx power Level 25	implementation dependent	static
dot11 Tx power Level 26	implementation dependent	static
dot11 Tx power Level 27	implementation dependent	static
dot11 Tx power Level 28	implementation dependent	static
dot11 Tx power Level 29	implementation dependent	static
dot11 Tx power Level 30	implementation dependent	static
dot11 Tx power Level 31	implementation dependent	static
dot11 Tx power Level 32	implementation dependent	static
dot11 Tx power Level 33	implementation dependent	static
dot11 Tx power Level 34	implementation dependent	static
dot11 Tx power Level 35	implementation dependent	static
dot11 Tx power Level 36	implementation dependent	static
dot11 Tx power Level 37	implementation dependent	static
dot11 Tx power Level 38	implementation dependent	static
dot11 Tx power Level 39	implementation dependent	static
dot11 Tx power Level 40	implementation dependent	static
dot11 Tx power Level 41	implementation dependent	static
dot11 Tx power Level 42	implementation dependent	static
dot11 Tx power Level 43	implementation dependent	static
dot11 Tx power Level 44	implementation dependent	static
dot11 Tx power Level 45	implementation dependent	static
dot11 Tx power Level 46	implementation dependent	static
dot11 Tx power Level 47	implementation dependent	static
dot11 Tx power Level 48	implementation dependent	static
dot11 Tx power Level 49	implementation dependent	static
dot11 Tx power Level 50	implementation dependent	static
dot11 Tx power Level 51	implementation dependent	static
dot11 Tx power Level 52	implementation dependent	static
dot11 Tx power Level 53	implementation dependent	static
dot11 Tx power Level 54	implementation dependent	static
dot11 Tx power Level 55	implementation dependent	static
dot11 Tx power Level 56	implementation dependent	static
dot11 Tx power Level 57	implementation dependent	static
dot11 Tx power Level 58	implementation dependent	static
dot11 Tx power Level 59	implementation dependent	static
dot11 Tx power Level 60	implementation dependent	static
dot11 Tx power Level 61	implementation dependent	static

TABLE 14 *Continued*

Managed Object	Default Value/Range	Operational Semantics
dot11 Tx power Level 62	implementation dependent	static
dot11 Tx power Level 63	implementation dependent	static
dot11 Tx power Level 64	implementation dependent	static
dot11 current Tx power level	implementation dependent	dynamic
dot11 reg domains supported	dot11 Reg Domains supported Table implementation dependent	static
dot11 frequency bands supported	implementation dependent dot11 PHY Antennas List Table	static
dot 11 supported Tx antenna	implementation dependent	static
dot11 supported Rx antenna	implementation dependent	static
dot 11 diversity selection Rx	implementation dependent	dynamic
dot11 supported data rates Tx value	dot11 supported Data Rates Tx Table 3, 4.5, 6, 9, 12, 18, 24, and 27 Mbit/s Mandatory Rates: 3, 6, and 12	static
dot11 supported data rates Rx value	dot11supportedDataRatesRxTable 3, 4.5, 6, 9, 12, 18, 24, and 27 Mbit/s Mandatory Rates: 3, 6, and 12 dot11 PHY OFDM Table	static
dot11 current frequency	implementation dependent	dynamic
dot11 TI threshold	implementation dependent	dynamic

^A From IEEE 802.11a. Copyright 1999 IEEE. All rights reserved.

TABLE 15 OFDM PHY Characteristics^A

Characteristics	Value
aSlotTime	16 μ s
aSIFSTime	32 μ s
aCCATime	<8 μ s
aRxTxTurnaroundTime	<2 μ s
aTxPLCPDelay	implementation dependent
aRxPLCPDelay	implementation dependent
aRxTxSwitchTime	<<1 μ s
aCHSwitchTime	<2 ms
aTxRampOnTime	implementation dependent
aTxRampOffTime	implementation dependent
aTxRFDelay	implementation dependent
aRxRFDelay	implementation dependent
aAirPropagationTime	<4 μ s
aMACProcessingDelay	<2 μ s
aPreambleLength	40 μ s
aPLCPHeaderLength	8 μ s
aMPDUMaxLength	4095
aCWmin	15
aCWmax	1023

^A From IEEE 802.11a. Copyright 1999 IEEE. All rights reserved.

TABLE 16 List of Parameters for the PMD Primitives^A

Parameter	Associate Primitive	Value
TXD_UNIT	PMD_DATA.request	one(1), zero(0): one OFDM symbol value
RXD_UNIT	PMD_DATA.indicate	one(1), zero(0): one OFDM symbol value
TXPWR_LEVEL	PMD_TXPWRLVL.request	1-64 (max of 64 levels)
RATE	PMD_RATE.request	6 Mbit/s (for BPSK) 12 Mbit/s (for QPSK) 24 Mbit/s (for 16-QAM) 36 Mbit/s (for 64-QAM)
RSSI	PMD_RSSI.indicate	0-8 bits of RSSI

^A From IEEE 802.11a. Copyright 1999 IEEE. All rights reserved.

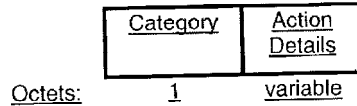

FIG. 16 Action Field

TABLE 17 Category Codes

Code	Meaning	See Paragraph
0-2	Assigned to other uses in 802.11	
3	DSRC management	9.2
4-127	Reserved	
128-255	Error	

TABLE 18 DSRC Action Codes

Code	Meaning
0	Regenerate MAC Address
1	Reserved
2	Nearby Station request
3	Nearby Station response
4- 255	Reserved

ANNEXES

(Mandatory Information)

A1. ASN.1 ENCODING OF THE MAC AND PHY MIB OF IEEE 802.11

A1.1 Add the following variables to the PHY MIB:⁵

1. In "Major sections" of Annex D, add the following text to the end of "PHY Attributes" section:

```
-- dot11PhyOFDMTable ::= {dot11phy 11}"
```

2. In "dot11PhyOperation TABLE" section of Annex D, update "dot11PHYType attribute" section as the following text:

```
"dot11PHYType OBJECT-TYPE
SYNTAX INTEGER {fhss(1), dsss(2), irbaseband(3), ofdm(4),
dsrc(5)}
MAX-ACCESS read-only
STATUS current
DESCRIPTION"
```

"This is an 8-bit integer value that identifies the PHY type supported by the attached PLCP and PMD. currently defined values and their corresponding PHY types are:

FHSS 2.4 GHz = 01, DSSS 2.4 GHz = 02, IR Baseband = 03, OFDM 5 GHz = 04, DSRC 5 GHz = 05"

```
::= {dot11PhyOperationEntry 1}
```

3. In Annex D, add the following text to the end of "dot11supportedDataRateRx TABLE" section:

```
.....
-- * dot11PhyOFDM TABLE
.....
```

```
dot11PhyOFDMTable OBJECT-TYPE
SYNTAX SEQUENCE OF Dot11PhyOFDMEntry
MAX-ACCESS not-accessible
STATUS current
DESCRIPTION
```

"Group of attributes for dot11PhyOFDMTable. Implemented as a table indexed on ifindex to allow for multiple instances on

an Agent.”

::= {dot11phy 11}

dot11PhyOFDMEntry OBJECT-TYPE

SYNTAX Dot11PhyOFDMEntry

MAX-ACCESS not-accessible

STATUS current

DESCRIPTION

“An entry in the dot11PhyOFDM Table.

ifIndex - Each IEEE 802.11 interface is represented by an ifEntry. Interface tables in this MIB module are indexed by ifIndex.”

INDEX {ifIndex}

::= {dot11PhyOFDMTable 1}

Dot11PhyOFDMEntry ::= SEQUENCE {

dot11currentFrequency INTEGER,

dot11TIThreshold INTEGER,

dot11FrequencyBandssupported}

dot11currentFrequency OBJECT-TYPE

SYNTAX INTEGER (0..200)

MAX-ACCESS read-write

STATUS current

DESCRIPTION

“The number of the current operating frequency channel of the OFDM PHY.”

::= {dot11PhyOFDMEntry 1}

dot11TIThreshold

SYNTAX INTEGER32

MAX-ACCESS read-write

STATUS current

DESCRIPTION

“The Threshold being used to detect a busy medium (frequency). CCA shall report a busy medium upon detecting the RSSI above this threshold.”

::= {dot11PhyOFDMEntry 2}

dot11FrequencyBandssupported

SYNTAX INTEGER (1..31)

MAX-ACCESS read-only

STATUS current

DESCRIPTION

“The capability of the OFDM PHY implementation to operate in the three U-NII bands. Coded as an integer value of a three bit field as follows:

bit 0 .. capable of operating in the lower (5.15-5.25 GHz) U-NII band

bit 1 .. capable of operating in the middle (5.25-5.35 GHz) U-NII band

bit 2 .. capable of operating in the upper (5.725-5.825 GHz) U-NII band

bit 3 .. capable of operating in the (5.850-5.925 GHz) ITS-RS band

For example, for an implementation capable of operating in the lower and mid bands this attribute would take the value 3.”

::= {dot11PhyOFDMEntry 3}

dot11deviceType OBJECT-TYPE

SYNTAX INTEGER (1..4)

MAX-ACCESS read-write

STATUS current

DESCRIPTION

“The device power Level: Class A=1, Class B=2, Class C=3, Class D=4.”

::= { dot11PhyOFDMEntry 4}

dot11ACRType OBJECT-TYPE

SYNTAX INTEGER (1..2)

MAX-ACCESS read-write

STATUS current

DESCRIPTION

“The Adjacent/Alternate Channel Rejection type.”

::= { dot11PhyOFDMEntry 5}

```

*****
-- * End of dot11PhyOFDM TABLE
--
*****

4. In Annex D, update "compliance statements" section as the following text:
*****
-- * compliance statements
--
*****
dot11Compliance MODULE-COMPLIANCE
STATUS current
DESCRIPTION
"The compliance statement for SNMPv2 entities
that implement the IEEE 802.11 MIB."
MODULE -- this module
MANDATORY-GROUPS {
dot11SMTbase,
dot11MACbase, dot11CountersGroup,
dot11SmtAuthenticationAlgorithms,
dot11ResourceTypeID, dot11PhyOperationComplianceGroup}

GROUP dot11PhyDSSSComplianceGroup
DESCRIPTION
"implementation of this group is required when object
dot11PHYType has the value of dsss. This group is
mutually exclusive with the groups dot11PhyIRComplianceGroup,
dot11PhyFHSSComplianceGroup and
dot11PhyOFDMComplianceGroup."

GROUP dot11PhyIRComplianceGroup
DESCRIPTION
"implementation of this group is required when object
dot11PHYType has the value of irbaseband. This group is
mutually exclusive with the groups
dot11PhyDSSSComplianceGroup,
dot11PhyFHSSComplianceGroup and
dot11PhyOFDMComplianceGroup."

GROUP dot11PhyFHSSComplianceGroup
DESCRIPTION
"implementation of this group is required when object
dot11PHYType has the value of fhss. This group is
mutually exclusive with the groups
dot11PhyDSSSComplianceGroup,
dot11PhyIRComplianceGroup and
dot11PhyOFDMComplianceGroup."

GROUP dot11OFDMComplianceGroup
DESCRIPTION
"implementation of this group is required when object
dot11PHYType has the value of ofdm. This group is
mutually exclusive with the groups
dot11PhyDSSSComplianceGroup,
dot11PhyIRComplianceGroup and
dot11PhyFHSSComplianceGroup."

-- OPTIONAL-GROUPS {dot11SMTprivacy, dot11MACStatistics,
-- dot11PhyAntennaComplianceGroup,
dot11PhyTxPowerComplianceGroup,
-- dot11PhyRegDomainsSupportGroup,
-- dot11PhyAntennasListGroup, dot11PhyRateGroup}
--

::= {dot11Compliances 1}

GROUP dot11PhyDSRCComplianceGroup
DESCRIPTION
"implementation of this group is required when object
dot11PHYType has the value of dsrc. This group is
mutually exclusive with the groups dot11PhyIRComplianceGroup
and dot11PhyFHSSComplianceGroup, but is compatible
with dot11PhyOFDMComplianceGroup and
dot11PhyDSSSComplianceGroup."

```

5. In "Groups - units of conformance" section of Annex D, add the following text to the end of "dot11CountersGroup" section:

```
"dot11PhyOFDMComplianceGroup OBJECT-GROUP
OBJECTS {
    dot11currentFrequency,
    dot11TIThreshold,
    dot11FrequencyBandssupported}
STATUS current
DESCRIPTION
"Attributes that configure the OFDM for IEEE 802.11."
::= {dot11Groups 17}"
```

```
"dot11PhyDSRCComplianceGroup OBJECT-GROUP
OBJECTS {
    dot11currentFrequency,
    dot11TIThreshold,
    dot11FrequencyBandssupported,
    dot11deviceType,
    dot11ACRType}
STATUS current
DESCRIPTION
"Attributes that configure the OFDM for DSRC."
::= {dot11Groups 18}"
```

A2. INITIAL EQUIPMENT STATE FOR DSRC OPERATIONS

TABLE A2.1 Example Registry Settings for a Typical DSRC Device

Characteristics	Value or Condition
bkScanEnable	0
bssType	3
rateCtrlEnable	1
SmeEnable	0
TransmitRate	0

A2.1 RSUs and OBUs shall implement a DSRC Ad-Hoc mode and the following settings on power-up to operate in the ITS-RS band. The RSU or OBU shall listen for incoming messages or internal commands in this state until commanded otherwise.

A2.1.1 Beacon scan shall be disabled.

A2.1.2 The channel shall be set to 178.

A2.1.3 The data rate shall be set to 6 Mbps.

A2.1.4 The unit shall be able to receive at any mandatory data rate.

A3. RSSI CALIBRATION FACTORS

A3.1 The DSRC standards make provision for accurately calibrating receiver sensitivity, vehicle RF attenuation parameters, and providing offset parameters for antenna centroids. These parameters are mandatory in order to support vehicle location by tracking of RSSI measurements. This provides an important mechanism for many applications that require knowledge of the vehicle position in close range applications. The applications that use this capability will specify the use of the RSSI, RSSI versus RF Power conversion table, calibration factors, and physical offsets. The purpose of this Annex is to establish common reference information to be used with the standard when using RSSI for RF location.

A3.2 *RSSI Conversion Table*—For any DSRC Radio it must be possible to create a calibrated RSSI versus RF Power

conversion table as part of the receiver data that permits the user to specify an exact receive power level for the device which is translated from a corresponding RSSI value for that receiver. This table should be created by the transponder manufacturer as part of the product and made it available to the applications. The RSSI versus RF Power conversion table is defined by measurements made under controlled conditions and consist of sufficient data points to provide ± 1 dBm accuracy over the receiver sensitivity specified in 8.3.1 of this document.

A3.3 *Transponder RSSI Calibration Factors*—The RSSI values that are measured by the PHY layer, may be calibrated for specific applications with additional Transponder RSSI calibration factors. It is the responsibility of the application

provider to perform this calibration and ensure that each transponder can carry this calibration factor in the application information.

A3.4 Antenna Position Calibration—Applications that depend on a specific physical location of the radio antenna on the vehicle need to know how much this location is displaced from the expected location. The expected location of the radio antenna is to be referenced to the centre of the front bumper of the vehicle, at a height of 0.25 m from the ground. Consequently, the mounted transponder, or the vehicle equipped with a transponder may be capable of providing these parameters to the RSU to enable proper correlation between antenna and

vehicle position. When provided, antenna position calibration is specified as three values:

A3.4.1 Antenna Position Axial (APA) Variation—The distance that the antenna is rearward of the front bumper. Range 0 to 12.7 m in 0.1 m increments.

A3.4.2 Antenna Position Width (APW) Variation—The distance that the antenna is left or right of the vehicle center. Range –3.1 to +3.1 m in 0.1 m increments, default value = 0.

A3.4.3 Antenna Position Height (APH) Variation—The distance that the antenna is above the nominal bumper height of 0.25 m. Value in 0.1 m increments.

APPENDIX

(Nonmandatory Information)

X1. CHANGES TO IEEE 802.11a, ANNEX A AND ANNEX D FOR DSRC UPDATE

X1.1 IUT Configuration⁵—This appendix includes only the parts of Annex A and Annex D that contain changes related to DSRC.

Item	IUT configuration	References	Status	Support
* CF1	Access point	5.2	O.1	Yes <input type="checkbox"/> No <input type="checkbox"/>
* CF2	Independent station (not an AP)	5.2	O.1	Yes <input type="checkbox"/> No <input type="checkbox"/>
* CF3	Frequency-hopping spread spectrum (FHSS) PHY for the 2.4 GHz band		O.2	Yes <input type="checkbox"/> No <input type="checkbox"/>
* CF4	Direct sequence spread spectrum (DSSS) PHY for the 2.4 GHz band		O.2	Yes <input type="checkbox"/> No <input type="checkbox"/>
* CF5	Infrared PHY		O.2	Yes <input type="checkbox"/> No <input type="checkbox"/>
* CF6	OFDM PHY for the 5 GHz band		O.2	Yes <input type="checkbox"/> No <input type="checkbox"/>
* CF7	DSRC PHY for the 5 GHz band		O.2	Yes <input type="checkbox"/> No <input type="checkbox"/>

X1.2 MAC Addressing Functions⁵—This table incorporates the OFDM PHY MAC Address Functions that have changed for DSRC implementation. The changes that apply to DSRC

are identified by the references listed in the ASTM E 2213-03 References column.

Item	MAC Address Function	IEEE 802.11a References	ASTM E 2213-03 References	Status	Support
	Are the following MAC Addressing functions supported?				
AD1	STA universal individual IEEE802 address	5.3.3, 7.1.3.3	---	M	Yes <input type="checkbox"/> No <input type="checkbox"/>
AD2	BSS identifier generation	7.1.3.3, 11.1.3, Annex C	---	M	Yes <input type="checkbox"/> No <input type="checkbox"/>
AD3	Receive address matching	7.1.3.3, 7.2.2, Annex C	---	M	Yes <input type="checkbox"/> No <input type="checkbox"/>
AD4	Random MAC Address	---	6.4.2, 7.1.4	M	Yes <input type="checkbox"/> No <input type="checkbox"/>

X1.3 Orthogonal Frequency Division Multiplex PHY Functions⁵—This table incorporates the OFDM PHY features that have changed for DSRC implementation. The changes that

apply to DSRC are identified by the references listed in the ASTM E 2213-03 References column.

Item	Feature	IEEE 802.11a References	ASTM E 2213-03 References	Status	Support
OF1: OFDM PHY Specific Service Parameters					
OF1.1	TXVECTOR parameter: LENGTH	---	8.2	M	Yes <input type="checkbox"/> No <input type="checkbox"/>
OF1.2	TXVECTOR parameter: DATARATE	---	8.2.1	M	Yes <input type="checkbox"/> No <input type="checkbox"/>
OF1.2.1	DATARATE = 3.0 Mbit/s	---	8.2.1	M	Yes <input type="checkbox"/> No <input type="checkbox"/>
*OF1.2.2	DATARATE = 4.5 Mbit/s	---	8.2.1	O	Yes <input type="checkbox"/> No <input type="checkbox"/>

Item	Feature	IEEE 802.11a References	ASTM E 2213-03 References	Status	Support
OF1.2.3	DATARATE = 6.0 Mbit/s	---	8.2.1	M	Yes <input type="checkbox"/> No <input type="checkbox"/>
*OF1.2.4	DATARATE = 9.0 Mbit/s	---	8.2.1	O	Yes <input type="checkbox"/> No <input type="checkbox"/>
OF1.2.5	DATARATE = 12.0 Mbit/s	---	8.2.1	M	Yes <input type="checkbox"/> No <input type="checkbox"/>
*OF1.2.6	DATARATE = 18.0 Mbit/s	---	8.2.1	O	Yes <input type="checkbox"/> No <input type="checkbox"/>
*OF1.2.7	DATARATE = 24.0 Mbit/s	---	8.2.1	O	Yes <input type="checkbox"/> No <input type="checkbox"/>
*OF1.2.8	DATARATE = 27.0 Mbit/s	---	8.2.1	O	Yes <input type="checkbox"/> No <input type="checkbox"/>
OF1.3	TXVECTOR parameter: SERVICE	---	8.2.1	M	Yes <input type="checkbox"/> No <input type="checkbox"/>
OF1.4	TXVECTOR parameter:TXPWR- _LEVEL	---	8.2.1	M	Yes <input type="checkbox"/> No <input type="checkbox"/>
OF1.5	RXVECTOR parameter: LENGTH	---	8.3	M	Yes <input type="checkbox"/> No <input type="checkbox"/>
OF1.6	RXVECTOR parameter: RSSI	---	8.3.1	M	Yes <input type="checkbox"/> No <input type="checkbox"/>
OF2: OFDM PLCP Sublayer					
OF2.1	RATE-dependent parameters	---	8.4	M	Yes <input type="checkbox"/> No <input type="checkbox"/>
OF2.2	Timing related parameters	---	8.4.1	M	Yes <input type="checkbox"/> No <input type="checkbox"/>
OF2.3	PLCP Preamble: SYNC	---	8.5	M	Yes <input type="checkbox"/> No <input type="checkbox"/>
OF2.4	PLCP header: SIGNAL	---	8.6	M	Yes <input type="checkbox"/> No <input type="checkbox"/>
OF2.5	PLCP header: LENGTH	---	8.6.1	M	Yes <input type="checkbox"/> No <input type="checkbox"/>
OF2.6	PLCP header: RATE	---	8.6.1.1	M	Yes <input type="checkbox"/> No <input type="checkbox"/>
OF2.7	PLCP header: parity, reserve	17.3.4.3		M	Yes <input type="checkbox"/> No <input type="checkbox"/>
OF2.8	PLCP header: SIGNAL TAIL	17.3.4.3		M	Yes <input type="checkbox"/> No <input type="checkbox"/>
OF2.9	PLCP header: SERVICE	17.3.5.1		M	Yes <input type="checkbox"/> No <input type="checkbox"/>
OF2.10	PPDU: TAIL	17.3.5.2		M	Yes <input type="checkbox"/> No <input type="checkbox"/>
OF2.11	PPDU: PAD	17.3.5.3		M	Yes <input type="checkbox"/> No <input type="checkbox"/>
OF2.12	PLCP/OFDM PHY data scrambler and descrambler	17.3.5.4		M	Yes <input type="checkbox"/> No <input type="checkbox"/>
OF2.13	Convolutional encoder	17.3.5.5		M	Yes <input type="checkbox"/> No <input type="checkbox"/>
OF2.13.1	Rate R = 1/2	17.3.5.5		M	Yes <input type="checkbox"/> No <input type="checkbox"/>
OF2.13.2	Punctured coding R = 2/3	17.3.5.5		OF1.2.7:M	Yes <input type="checkbox"/> No <input type="checkbox"/> N/A <input type="checkbox"/>
OF2.13.3	Punctured coding R = 3/4	17.3.5.5		OF1.2.2 OR OF1.2.4 OR OF1.2.6 OR OF1.2.8:M	Yes <input type="checkbox"/> No <input type="checkbox"/> N/A <input type="checkbox"/>
OF2.14	Data interleaving	17.3.5.6		M	Yes <input type="checkbox"/> No <input type="checkbox"/>
OF2.15	Subcarrier modulation mapping	17.3.5.7		M	Yes <input type="checkbox"/> No <input type="checkbox"/>
OF2.15.1	BPSK	17.3.5.7		M	Yes <input type="checkbox"/> No <input type="checkbox"/>
OF2.15.2	QPSK	17.3.5.7		M	Yes <input type="checkbox"/> No <input type="checkbox"/>
OF2.15.3	16-QAM	17.3.5.7		M	Yes <input type="checkbox"/> No <input type="checkbox"/>
OF2.15.4	64-QAM	17.3.5.7		OF1.2.7 OR OF1.2.8:M	Yes <input type="checkbox"/> No <input type="checkbox"/> N/A <input type="checkbox"/>
OF2.16	Pilot subcarriers	17.3.5.8		M	Yes <input type="checkbox"/> No <input type="checkbox"/>
OF2.17	OFDM modulation	17.3.5.9		M	Yes <input type="checkbox"/> No <input type="checkbox"/>
OF2.18	Packet duration calculation	17.3.5.10		M	Yes <input type="checkbox"/> No <input type="checkbox"/>
OF2.19	CCA				
OF2.19.1	CCA: RSSI	17.3.6	7.1.1	M	Yes <input type="checkbox"/> No <input type="checkbox"/>
OF2.19.2	CCA: indication to MAC sublayer	17.3.6		M	Yes <input type="checkbox"/> No <input type="checkbox"/>
OF2.20	PLCP data modulation and modulation rate change	---	8.7	M	Yes <input type="checkbox"/> No <input type="checkbox"/>
OF3: PDM Operating Specification General					
OF3.1	Occupied channel bandwidth	---	8.8.3	M	Yes <input type="checkbox"/> No <input type="checkbox"/>
OF3.2	Operating frequency range	---	8.8.3	M	Yes <input type="checkbox"/> No <input type="checkbox"/>
OF3.3	Channelization	---	8.8.3.3	M	Yes <input type="checkbox"/> No <input type="checkbox"/>
*OF3.3.1	Lower U-NII subband (5.15-5.25 GHz)	17.3.8.3		O.1	Yes <input type="checkbox"/> No <input type="checkbox"/>
*OF3.3.2	Middle U-NII subband (5.25-5.35 GHz)	17.3.8.3		O.1	Yes <input type="checkbox"/> No <input type="checkbox"/>
*OF3.3.3	Upper U-NII subband (5.725-5.825 GHz)	17.3.8.3		O.1	Yes <input type="checkbox"/> No <input type="checkbox"/>
*OF3.3.4	ITS-RS band (5.850-5.925 GHz)	---	8.8.3	O.1	Yes <input type="checkbox"/> No <input type="checkbox"/>
OF3.4	number of operating channels	---	8.8.3	M	Yes <input type="checkbox"/> No <input type="checkbox"/>
OF3.5	Operating channel frequencies	---	8.8.3	M	Yes <input type="checkbox"/> No <input type="checkbox"/>
OF3.6	Transmit and receive in band and out of band spurious emission	---	8.9.3	M	Yes <input type="checkbox"/> No <input type="checkbox"/>
OF3.7	TX RF delay	17.3.8.5		M	Yes <input type="checkbox"/> No <input type="checkbox"/>
OF3.8	Slot Time	---	8.8.4	M	Yes <input type="checkbox"/> No <input type="checkbox"/>

Item	Feature	IEEE 802.11a References	ASTM E 2213-03 References	Status	Support
OF3.9	Transmit and receive antenna port impedance	---	8.8.5	M	Yes <input type="checkbox"/> No <input type="checkbox"/>
OF3.10	Transmit and receive operating temperature range	---	8.8.6	M	Yes <input type="checkbox"/> No <input type="checkbox"/>
OF3.10.1	Type 1 (0 °C to 40 °C)	---	8.8.6	M	Yes <input type="checkbox"/> No <input type="checkbox"/>
OF3.10.2	Type 2 (20 °C to 50 °C)	---	8.8.6	O	Yes <input type="checkbox"/> No <input type="checkbox"/>
OF3.10.3	Type 3 (30 °C to 70 °C)	---	8.8.6	O	Yes <input type="checkbox"/> No <input type="checkbox"/>
OF3.10.4	Type 4 (40 °C to 85 °C)	---	8.8.6	O	Yes <input type="checkbox"/> No <input type="checkbox"/>
OF4: PMD Transmit Specification					
OF4.1	Transmit power Levels	---	8.9.1	M	Yes <input type="checkbox"/> No <input type="checkbox"/>
OF4.1.1	Power Level (5.15-5.25 GHz)	17.3.9.1		OF3.3.1:M	Yes <input type="checkbox"/> No <input type="checkbox"/> N/A <input type="checkbox"/>
OF4.1.2	Power Level (5.25-5.35 GHz)	17.3.9.1		OF3.3.2:M	Yes <input type="checkbox"/> No <input type="checkbox"/> N/A <input type="checkbox"/>
OF4.1.3	Power Level (5.725-5.825 GHz)	17.3.9.1		OF3.3.3:M	Yes <input type="checkbox"/> No <input type="checkbox"/> N/A <input type="checkbox"/>
OF4.1.4	Class A device Power Level (5.850-5.925 GHz)	---	8.9.1.10	OF3.3.3:M	Yes <input type="checkbox"/> No <input type="checkbox"/> N/A <input type="checkbox"/>
OF4.1.5	Class B device Power Level (5.850-5.925 GHz)	---	8.9.1.10	OF3.3.3:M	Yes <input type="checkbox"/> No <input type="checkbox"/> N/A <input type="checkbox"/>
OF4.1.6	Class C device Power Level (5.850-5.925 GHz)	---	8.9.1.10	OF3.3.3:M	Yes <input type="checkbox"/> No <input type="checkbox"/> N/A <input type="checkbox"/>
OF4.1.7	Class D device Power Level (5.850-5.925 GHz)	---	8.9.1.10	OF3.3.3:M	Yes <input type="checkbox"/> No <input type="checkbox"/> N/A <input type="checkbox"/>
OF4.2	Spectrum mask	---	8.9.2	M	Yes <input type="checkbox"/> No <input type="checkbox"/>
OF4.2.1	Class A device Spectrum Mask (5.850- 5.925 GHz)	---	8.9.2.2	OF3.3.3:M	Yes <input type="checkbox"/> No <input type="checkbox"/> N/A <input type="checkbox"/>
OF4.2.2	Class B device Spectrum Mask (5.850- 5.925 GHz)	---	8.9.2.2	OF3.3.3:M	Yes <input type="checkbox"/> No <input type="checkbox"/> N/A <input type="checkbox"/>
OF4.2.3	Class C device Spectrum Mask (5.850- 5.925 GHz)	---	8.9.2.2	OF3.3.3:M	Yes <input type="checkbox"/> No <input type="checkbox"/> N/A <input type="checkbox"/>
OF4.2.4	Class D device Spectrum Mask (5.850- 5.925 GHz)	---	8.9.2.2	OF3.3.3:M	Yes <input type="checkbox"/> No <input type="checkbox"/> N/A <input type="checkbox"/>
OF4.3	Spurious	---	8.9.3	M	Yes <input type="checkbox"/> No <input type="checkbox"/>
OF4.4	Left frequency tolerance	---	8.9.4	M	Yes <input type="checkbox"/> No <input type="checkbox"/>
OF4.5	Clock frequency tolerance	---	8.9.5	M	Yes <input type="checkbox"/> No <input type="checkbox"/>
OF4.6	Modulation accuracy	---	8.9.6	M	Yes <input type="checkbox"/> No <input type="checkbox"/>
OF4.6.1	Left frequency leakage	---	8.9.6.1	M	Yes <input type="checkbox"/> No <input type="checkbox"/>
OF4.6.2	Spectral flatness	---	8.9.6.2	M	Yes <input type="checkbox"/> No <input type="checkbox"/>
OF4.6.3	Transmitter constellation error< 5 dB	---	8.9.6.3	M	Yes <input type="checkbox"/> No <input type="checkbox"/>
OF4.6.4	Transmitter constellation error< 8 dB	---	8.9.6.3	OF1.2.2:M	Yes <input type="checkbox"/> No <input type="checkbox"/> N/A <input type="checkbox"/>
OF4.6.5	Transmitter constellation error< 10 dB	---	8.9.6.3	M	Yes <input type="checkbox"/> No <input type="checkbox"/>
OF4.6.6	Transmitter constellation error< 13 dB	---	8.9.6.3	OF1.2.4:M	Yes <input type="checkbox"/> No <input type="checkbox"/> N/A <input type="checkbox"/>
OF4.6.7	Transmitter constellation error< 16 dB	---	8.9.6.3	M	Yes <input type="checkbox"/> No <input type="checkbox"/>
OF4.6.8	Transmitter constellation error< 19 dB	---	8.9.6.3	OF1.2.6:M	Yes <input type="checkbox"/> No <input type="checkbox"/> N/A <input type="checkbox"/>
OF4.6.9	Transmitter constellation error< 22 db	---	8.9.6.3	OF1.2.7:M	Yes <input type="checkbox"/> No <input type="checkbox"/> N/A <input type="checkbox"/>
OF4.6.10	Transmitter constellation error< 25 dB	---	8.9.6.3	OF1.2.8:M	Yes <input type="checkbox"/> No <input type="checkbox"/> N/A <input type="checkbox"/>
OF5: PMD Receiver Specifications					
OF5.1	Minimum input Level sensitivity at PER = 10 % with 1000 octet frames	---	8.10.1		
OF5.1.1	-85 dBm for 3 Mbit/s	---	8.10.1	M	Yes <input type="checkbox"/> No <input type="checkbox"/>
OF5.1.2	-84 dBm for 4.5 Mbit/s	---	8.10.1	OF1.2.2:M	Yes <input type="checkbox"/> No <input type="checkbox"/> N/A <input type="checkbox"/>
OF5.1.3	-82 dBm for 6 Mbit/s	---	8.10.1	M	Yes <input type="checkbox"/> No <input type="checkbox"/>
OF5.1.4	-80 dBm for 9 Mbit/s	---	8.10.1	OF1.2.4:M	Yes <input type="checkbox"/> No <input type="checkbox"/> N/A <input type="checkbox"/>
OF5.1.5	-77 dBm for 12 Mbit/s	---	8.10.1	M	Yes <input type="checkbox"/> No <input type="checkbox"/>
OF5.1.6	-70 dBm for 18Mbit/s	---	8.10.1	OF1.2.6:M	Yes <input type="checkbox"/> No <input type="checkbox"/> N/A <input type="checkbox"/>
OF5.1.7	-69 dBm for 24 Mbit/s	---	8.10.1	OF1.2.7:M	Yes <input type="checkbox"/> No <input type="checkbox"/> N/A <input type="checkbox"/>

Item	Feature	IEEE 802.11a References	ASTM E 2213-03 References	Status	Support
OF5.1.8	-67 dBm for 27 Mbit/s	---	8.10.1	OF1.2.8:M	Yes <input type="checkbox"/> No <input type="checkbox"/> N/A <input type="checkbox"/>
OF5.2	Adjacent channel rejection	---	8.10.2	M	Yes <input type="checkbox"/> No <input type="checkbox"/>
OF5.2.1	Type 1 (802.11a compliant)	17.3.10.2		M	Yes <input type="checkbox"/> No <input type="checkbox"/>
OF5.2.2	Type 2 (DSRC enhanced)	---	8.10.2	O	Yes <input type="checkbox"/> No <input type="checkbox"/> N/A <input type="checkbox"/>
OF5.3	Non-adjacent channel rejection	---	8.10.3	M	Yes <input type="checkbox"/> No <input type="checkbox"/>
OF5.3.1	Type 1 (802.11a compliant)	17.3.10.3		M	Yes <input type="checkbox"/> No <input type="checkbox"/>
OF5.3.2	Type 2 (DSRC enhanced)	---	8.10.3	O	Yes <input type="checkbox"/> No <input type="checkbox"/> N/A <input type="checkbox"/>
OF5.4	Maximum input Level	17.3.10.4		M	Yes <input type="checkbox"/> No <input type="checkbox"/>
OF5.5	CCA sensitivity	---	8.10.4	M	Yes <input type="checkbox"/> No <input type="checkbox"/>
OF5.6	Multi-path Delay Spread	---	8.10.5	M	Yes <input type="checkbox"/> No <input type="checkbox"/>
OF5.7	Doppler Spread	---	8.10.6	M	Yes <input type="checkbox"/> No <input type="checkbox"/>
OF5.8	Amplitude Variation	---	8.10.7	M	Yes <input type="checkbox"/> No <input type="checkbox"/>
OF5.9	Rician Channel Variation	---	8.10.8	M	Yes <input type="checkbox"/> No <input type="checkbox"/>
OF6: PLCP Transmit Procedure					
OF6.1	Transmit: transmit on MAC request	17.3.13		M	Yes <input type="checkbox"/> No <input type="checkbox"/>
OF6.2	Transmit: format and data encoding	17.3.13		M	Yes <input type="checkbox"/> No <input type="checkbox"/>
OF6.3	Transmit: timing	17.3.13		M	Yes <input type="checkbox"/> No <input type="checkbox"/>
OF7: PLCP Receive Procedure					
OF7.1	Receive: receive and data decoding	17.3.14		M	Yes <input type="checkbox"/> No <input type="checkbox"/>
OF8: PHY LME					
OF8.1	PLME: support PLME_SAP management primitives	17.4.1		M	Yes <input type="checkbox"/> No <input type="checkbox"/>
OF8.2	PLME: support PHY management information base	17.4.2		M	Yes <input type="checkbox"/> No <input type="checkbox"/>
OF8.3	PLME: support PHY characteristics	17.4.3		M	Yes <input type="checkbox"/> No <input type="checkbox"/>
OF9: OFDM PMD Sublayer					
OF9.1	PMD: support PMD_SAP peer-to-peer service primitives	17.5.4.1, 17.5.5.1, 17.5.5.2		M	Yes <input type="checkbox"/> No <input type="checkbox"/>
OF9.2	PMD: support PMD_SAP sublayer-to- sublayer service primitives	---	8.13	M	Yes <input type="checkbox"/> No <input type="checkbox"/>
OF9.3	PMD_SAP service primitive parameters	---	8.13		
OF9.3.1	Parameter: TXD_UNIT	---	8.13	M	Yes <input type="checkbox"/> No <input type="checkbox"/>
OF9.3.2	Parameter: RXD_UNIT	---	8.13	M	Yes <input type="checkbox"/> No <input type="checkbox"/>
OF9.3.3	Parameter: TXPWR_LEVEL	---	8.13	M	Yes <input type="checkbox"/> No <input type="checkbox"/>
OF9.3.4	Parameter: RATE (3 Mbit/s)	---	8.13	M	Yes <input type="checkbox"/> No <input type="checkbox"/>
OF9.3.5	Parameter: RATE (6 Mbit/s)	---	8.13	M	Yes <input type="checkbox"/> No <input type="checkbox"/>
OF9.3.6	Parameter: RATE (12Mbit/s)	---	8.13	M	Yes <input type="checkbox"/> No <input type="checkbox"/>
OF9.3.7	Parameter: RATE (24 Mbit/s)	---	8.13	O	Yes <input type="checkbox"/> No <input type="checkbox"/>
OF9.3.8	Parameter: RSSI	---	8.13	M	Yes <input type="checkbox"/> No <input type="checkbox"/>
OF10: Geographic Area Specific Requirements					
*OF10.1	Geographic areas	17.3.8.2, 17.3.8.3, 17.3.8.4, 17.3.9.3		M	Yes <input type="checkbox"/> No <input type="checkbox"/>

ASTM International takes no position respecting the validity of any patent rights asserted in connection with any item mentioned in this standard. Users of this standard are expressly advised that determination of the validity of any such patent rights, and the risk of infringement of such rights, are entirely their own responsibility.

This standard is subject to revision at any time by the responsible technical committee and must be reviewed every five years and if not revised, either reapproved or withdrawn. Your comments are invited either for revision of this standard or for additional standards and should be addressed to ASTM International Headquarters. Your comments will receive careful consideration at a meeting of the responsible technical committee, which you may attend. If you feel that your comments have not received a fair hearing you should make your views known to the ASTM Committee on Standards, at the address shown below.

This standard is copyrighted by ASTM International, 100 Barr Harbor Drive, PO Box C700, West Conshohocken, PA 19428-2959, United States. Individual reprints (single or multiple copies) of this standard may be obtained by contacting ASTM at the above address or at 610-832-9585 (phone), 610-832-9555 (fax), or service@astm.org (e-mail); or through the ASTM website (www.astm.org).