



Standard Test Method for Failure End Point in Accelerated and Outdoor Weathering of Bituminous Materials¹

This standard is issued under the fixed designation D 1670; the number immediately following the designation indicates the year of original adoption or, in the case of revision, the year of last revision. A number in parentheses indicates the year of last reapproval. A superscript epsilon (ϵ) indicates an editorial change since the last revision or reapproval.

1. Scope

1.1 This test method covers the use of a spark generating apparatus for determination of failure due to cracking of bituminous materials undergoing accelerated or outdoor weathering on electrically conductive backings.

1.2 The values stated in SI units are to be regarded as the standard. The values given in parentheses are for information only.

1.3 *This standard does not purport to address all of the safety concerns, if any, associated with its use. It is the responsibility of the user of this standard to establish appropriate safety and health practices and determine the applicability of regulatory limitations prior to use.*

2. Referenced Documents

2.1 ASTM Standards:²

D 529 Practice for Enclosed Carbon-Arc Exposures of Bituminous Materials

D 1435 Practice for Outdoor Weathering of Plastics

D 1669 Practice for Preparation of Test Panels for Accelerated and Outdoor Weathering of Bituminous Materials

D 4798 Practice for Accelerated Weathering Test Conditions and Procedures for Bituminous Materials (Xenon-Arc Method)

D 4799 Practice for Accelerated Weathering Test Conditions and Procedures for Bituminous Materials (Fluorescent UV, Water Spray, and Condensation Method)

3. Summary of Test Method

3.1 Dry, weathered, bituminous-coated test panels are grounded and a feeler electrode is passed over the back of a linagraphic or ultra high sensitivity thermal fax paper placed on the bituminous surface with the emulsion side down. Photocopies are made of the front side of the paper on which the

spots caused by the sparks appear. The photographs are covered with an acrylic grid and the number of squares containing the spark records are counted and reported. Sparking in 26 or more grid squares is representative of failure.

4. Significance and Use

4.1 The extent of cracking or pitting of bituminous films is a measure of the extent of deterioration due to weathering. Failure due to cracking is more accurately determined electrically than visually.

4.2 Failure determined by this test method will depend not only on the characteristics of the bituminous material and the extent of weathering, but also on the film thickness, and the amount and type of mineral filler present.

4.3 Tests on a similar material of known weathering characteristics (a control) exposed at the same time as the test material is strongly recommended as a check on the validity of the test results.

5. Apparatus

5.1 *Any Spark-Generating Apparatus*³—Fig. 1 is an example of an acceptable configuration for the test feeler. Other configurations are not prohibited, subject to the following conditions:

5.1.1 The cross-dimension of the wire loop is to be 50 ± 5 mm ($1\frac{3}{4} \pm \frac{1}{8}$ in.).

5.1.2 The device is capable of delivering a 5-kV peak voltage and of operating at 60 Hz.

5.2 *Photographic Equipment*—A supply of sheets of matte surface, regular weight, photocopy paper⁴ or linagraphic paper cut to the dimensions of the test panel, developer, and fixing chemicals.

5.3 *Counting Grid*, as shown in Fig. 2. Photocopy the grid on a transparency film that is suitable for use with plain paper

¹ This test method is under the jurisdiction of ASTM Committee D08 on Roofing and Waterproofing and is the direct responsibility of Subcommittee D08.02 on Prepared Roofings, Shingles, and Siding Materials.

Current edition approved May 1, 2004. Published May 2004. Originally approved in 1959. Last previous edition approved in 2003 as D 1670 – 98 (2003).

² For referenced ASTM standards, visit the ASTM website, www.astm.org, or contact ASTM Customer Service at service@astm.org. For *Annual Book of ASTM Standards* volume information, refer to the standard's Document Summary page on the ASTM website.

³ The sole source of supply of the apparatus known to the committee at this time is Electrotech Model BD-40B Spark Generator, available from Electro-Technic Products Co., 4642 N. Ravenswood Ave., Chicago, IL 60642. If you are aware of alternative suppliers, please provide this information to ASTM Headquarters. Your comments will receive careful consideration at a meeting of the responsible technical committee,¹ which you may attend.

⁴ Thermal facsimile paper with ultra-high sensitivity rating has also been found satisfactory for the same purpose. This paper is available nationwide from office supply stores or catalogs.

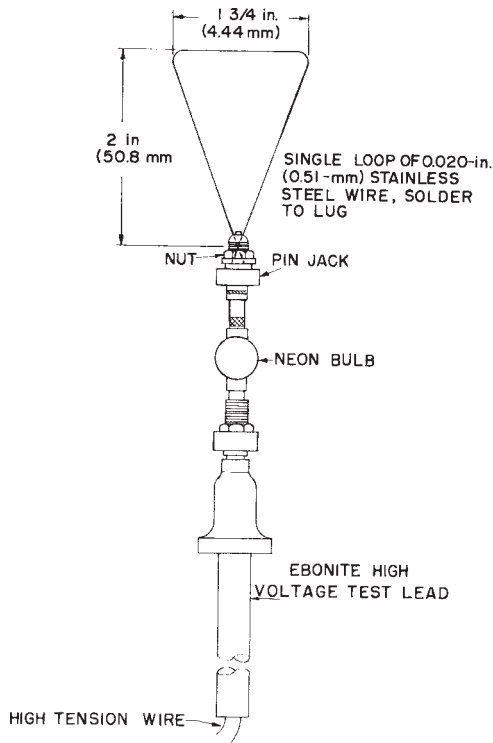

FIG. 1 Feeler

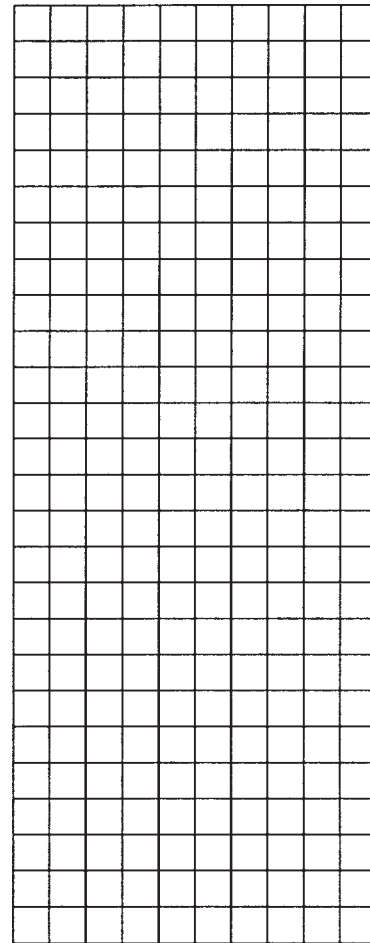

FIG. 2 Counting Grid

copiers. Trim the outside edges to the exact dimensions of the test panel making sure that the grid and the bituminous film on the test panel are aligned.

Outside dimensions, mm (in.)	69.8 by 149.1 (2¾ by 5⅞) or panel size
Grid dimensions, mm (in.)	47.6 by 123.8 (1⅞ by 4⅞)
Number of squares in grid	260 (10 by 26)
Size of squares, mm (in.)	4.76 (¾)

6. Test Specimens

6.1 Unless otherwise agreed upon, test specimens shall be prepared in accordance with Practice D 1669.

7. Calibration of the Spark-Generating Apparatus

7.1 *Voltage*—Calibrate the peak voltage of the spark generator to 5 ± 0.5 kV according to the manufacturer's instructions.

8. Procedures for Weathering

8.1 *Outdoor Weathering*—Expose specimens to outdoor weathering in accordance with requirements of Practice D 1435 at a site, rack angle and backing to be agreed on by the interested parties.

8.2 *Laboratory Accelerated Weathering*—Expose specimens to laboratory accelerated weathering in accordance with procedures described in Practice D 529, D 4798, or D 4799. The practice used and the specific test condition selected from the practice shall be by agreement between the interested parties.

8.2.1 The three laboratory Practices D 529, D 4798, and D 4799 utilize light sources with very different emission

characteristics. Therefore, the practices may be expected to produce different test results. In addition, the alternate test conditions in each of the practices may also be expected to produce different test results. Therefore, the report of time to failure must be accompanied by reference to the practice used for exposure and the specific test conditions.

9. Detection of Cracks in Weathered Film

9.1 At the end of an exposure period, remove the test panel from the weathering unit or outdoor exposure site. Allow the panels to dry thoroughly and bring them to room temperature.

9.2 Ground each panel at the back surface or the conductive edge. The test feeler (see Fig. 1) of the spark instrument should be passed over the complete surface of the bituminous film in 5 to 10 s. The number of sparks should be noted during the pass. If the number of sparkthrough points on any panel is less than 15, at least 3/16 in. apart, set the panel aside for re-exposure. Make a photographic record of the rest of the specimens showing sparking in 15 or more positions. Place one of the photocopy sheets or linagraphic paper (cut to the exact dimensions of the test panel) emulsion side down on the panel, making sure that the sheet and the panel are aligned, and pass

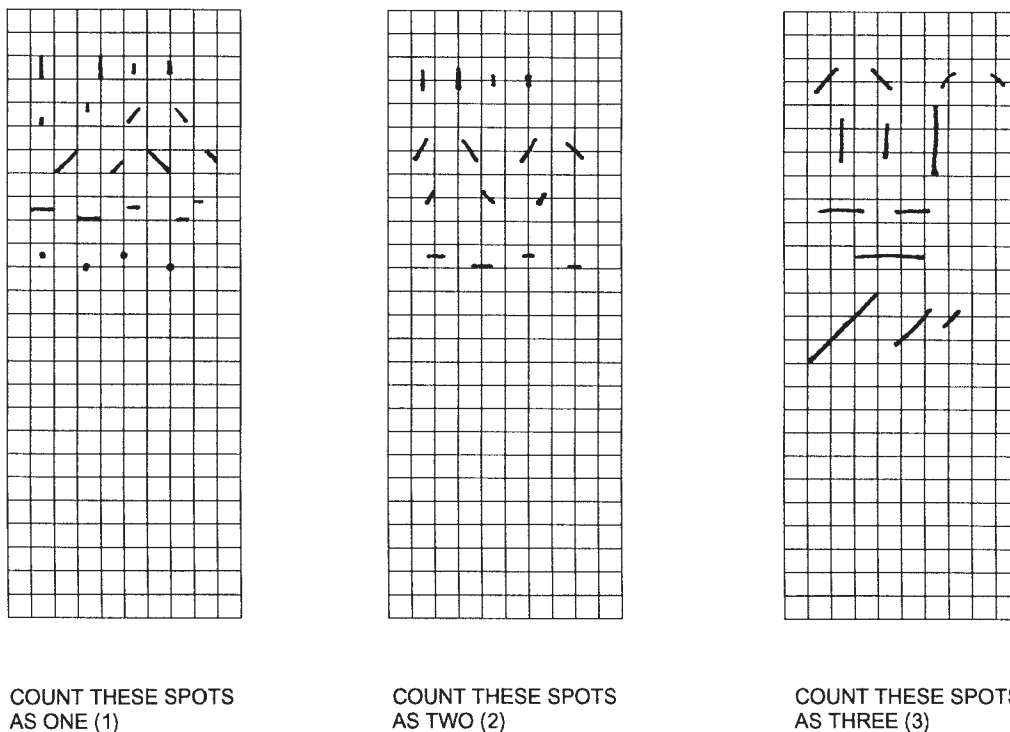

FIG. 3 Guidelines to Determine Cracks (Spots) Weathered Bituminous Films

the test feeler of the spark gap instrument over the back of the paper.⁵ The complete passage from top to bottom shall be within 5 to 10 s. Stroke the feeler across the surface from side to side to ensure complete recording of all cracks. Then, if necessary, develop the paper in the manner of an ordinary photographic print.

9.3 Cover each photograph with the transparent counting grid so that the outer dimensions of the grid and the outer dimensions of the photographic paper are aligned, and the inner grid is centered in the area of the bituminous material. Record the number of squares in which spots appear following the guidelines shown in Fig. 3.

9.4 Continue the exposure of the panels until sparking occurs in at least 26 grid squares.

9.5 Designate the failure end point of the specimen as the exposure time after which sparkthrough points first occurred in 26 of the grid squares. This number of failure points is equivalent to a 10 % failure.

10. Report

10.1 Report the following information:

10.1.1 Complete identification of the test material and control material, if used, including the type, amount and type of mineral filler, source, and manufacturer’s code number,

10.1.2 Thickness, width, and length of specimens,

10.1.3 The exposure practice and cycle (conditions) used to degrade specimens,

10.1.4 Any deviation from the standard test conditions specified in the exposure practice,

10.1.5 Any additional report requirements listed in the exposure practice, and

10.1.6 The exposure time after which sparkthrough points first occurred in 26 of the grid squares in each of the replicate specimens and average of the replicates.

11. Precision⁶

11.1 The following criterion shall be used for judging the acceptability of results (95 % probability):

11.1.1 The values reported by each of two laboratories, representing the arithmetic average of duplicate determinations, shall not be considered suspect unless the reported counts differ by more than 19 %.

12. Keywords

12.1 accelerated weathering; bituminous materials; failure end point; outdoor weathering

⁵ A discussion of the photographic method of recording failures is given in “A New Method for Evaluating Failure of Bituminous Materials Due to Weathering,” by Hunter, J. B., Gezinski, F. C., and Laskaris, L., *ASTM STP 94*, ASTM, 1949, pp. 144-152.

⁶ A copy of the research report used to develop the precision statement is available from ASTM International Headquarters. Request RR: D08-1009.

ASTM International takes no position respecting the validity of any patent rights asserted in connection with any item mentioned in this standard. Users of this standard are expressly advised that determination of the validity of any such patent rights, and the risk of infringement of such rights, are entirely their own responsibility.

This standard is subject to revision at any time by the responsible technical committee and must be reviewed every five years and if not revised, either reapproved or withdrawn. Your comments are invited either for revision of this standard or for additional standards and should be addressed to ASTM International Headquarters. Your comments will receive careful consideration at a meeting of the responsible technical committee, which you may attend. If you feel that your comments have not received a fair hearing you should make your views known to the ASTM Committee on Standards, at the address shown below.

This standard is copyrighted by ASTM International, 100 Barr Harbor Drive, PO Box C700, West Conshohocken, PA 19428-2959, United States. Individual reprints (single or multiple copies) of this standard may be obtained by contacting ASTM at the above address or at 610-832-9585 (phone), 610-832-9555 (fax), or service@astm.org (e-mail); or through the ASTM website (www.astm.org).