



# Standard Specification for Aluminum-Pigmented Asphalt Roof Coatings, Non-Fibered, Asbestos Fibered, and Fibered without Asbestos<sup>1</sup>

This standard is issued under the fixed designation D 2824; the number immediately following the designation indicates the year of original adoption or, in the case of revision, the year of last revision. A number in parentheses indicates the year of last reapproval. A superscript epsilon ( $\epsilon$ ) indicates an editorial change since the last revision or reapproval.

*This standard has been approved for use by agencies of the Department of Defense.*

## 1. Scope

1.1 This specification covers asphalt-based, aluminum roof coatings suitable for application to roofing or masonry surfaces by brush or spray.

1.2 The values stated in inch-pound units are to be regarded as the standard.

1.3 The following precautionary caveat pertains only to the test method portion, Section 8, of this specification: *This standard does not purport to address all of the safety concerns, if any, associated with its use. It is the responsibility of the user of this standard to establish appropriate safety and health practices and determine the applicability of regulatory limitations prior to use.*

## 2. Referenced Documents

### 2.1 ASTM Standards:

- D 4 Test Method for Bitumen Content<sup>2</sup>
- D 95 Test Method for Water in Petroleum Products and Bituminous Materials by Distillation<sup>3</sup>
- D 140 Practice for Sampling Bituminous Materials<sup>4</sup>
- D 562 Test Method for Consistency of Paints Using the Stormer Viscometer<sup>5</sup>
- D 962 Specification for Aluminum Powder and Paste Pigments for Paints<sup>6</sup>
- D 2823 Specification for Asphalt Roof Coatings<sup>2</sup>
- D 3279 Test Method for *n*-Heptane Insolubles<sup>4</sup>
- E 200 Practice for Preparation, Standardization, and Storage of Standard Solutions for Chemical Analysis<sup>7</sup>

## 3. Classification

3.1 *Type I*—Nonfibered, containing no fiber.

3.2 *Type II*—Fibered, containing asbestos fiber.

3.3 *Type III*—Fibered, containing no asbestos fiber.

## 4. Materials and Manufacture

4.1 Asphalt-based, aluminum roof coatings shall consist of an asphalt base, volatile petroleum solvents, and a leafing-type of aluminum pigment conforming to the requirements of Specification D 962, with or without fiber added. They shall be mixed to a smooth, uniform consistency suitable for application by brush, roller, or by spraying.

## 5. Composition

5.1 Asphalt-based, aluminum roof coatings complying with this specification shall conform to the following composition limits:

	Type I	Type II or Type III
Water, max, %	0.3	0.3
Nonvolatile matter (NVM), min, %	40	40
Insoluble in CS <sub>2</sub> , max, % of NVM	40	50
Metallic aluminum, min, %	11	9

## 6. Physical Requirements

6.1 *Uniformity*—After a thoroughly stirred sample has stood for 72 h at room temperature 73.4  $\pm$  0.5 °F (23  $\pm$  0.3 °C) in a closed container, it shall show no separation of solvent or settling that can not be overcome by moderate stirring.

6.2 *Consistency*—The roof coating shall be of a consistency that will spread readily and permit application by brush, roller, or spray to produce a film in which the aluminum pigment leafs to form a bright reflective surface on prepared roofing, saturated felt, and metal surfaces at ambient temperatures above 50°F (10°C).

6.2.1 *Type I*—Consistency at 77°F (25°C) shall be between 20 and 30 Stormer s/100 revolutions of the paddle-type rotor with a 100-g load in addition to the standardizing load.

6.2.2 *Type II*—Consistency at 77°F (25°C) shall be between 15 and 90 Stormer s/100 revolutions of the propeller-type rotor (Fig. 1) with a 300-g load in addition to the standardizing load.

6.3 *Reflectance*—The percent luminous reflectance of coatings, determined on samples before and after high temperature shelf aging, shall be not less than 50 %.

<sup>1</sup> This specification is under the jurisdiction of ASTM Committee D-8 on Roofing, Waterproofing, and Bituminous Materials and is the direct responsibility of Subcommittee D08.05 on Solvent-Bearing Bituminous Compounds for Roofing and Waterproofing.

Current edition approved May 15, 1994. Published July 1994. Originally published as D 2824 – 69. Last previous edition D 2824 – 85.

<sup>2</sup> *Annual Book of ASTM Standards*, Vol 04.04.

<sup>3</sup> *Annual Book of ASTM Standards*, Vol 05.01.

<sup>4</sup> *Annual Book of ASTM Standards*, Vol 04.03.

<sup>5</sup> *Annual Book of ASTM Standards*, Vol 06.01.

<sup>6</sup> *Annual Book of ASTM Standards*, Vol 06.03.

<sup>7</sup> *Annual Book of ASTM Standards*, Vol 15.05.

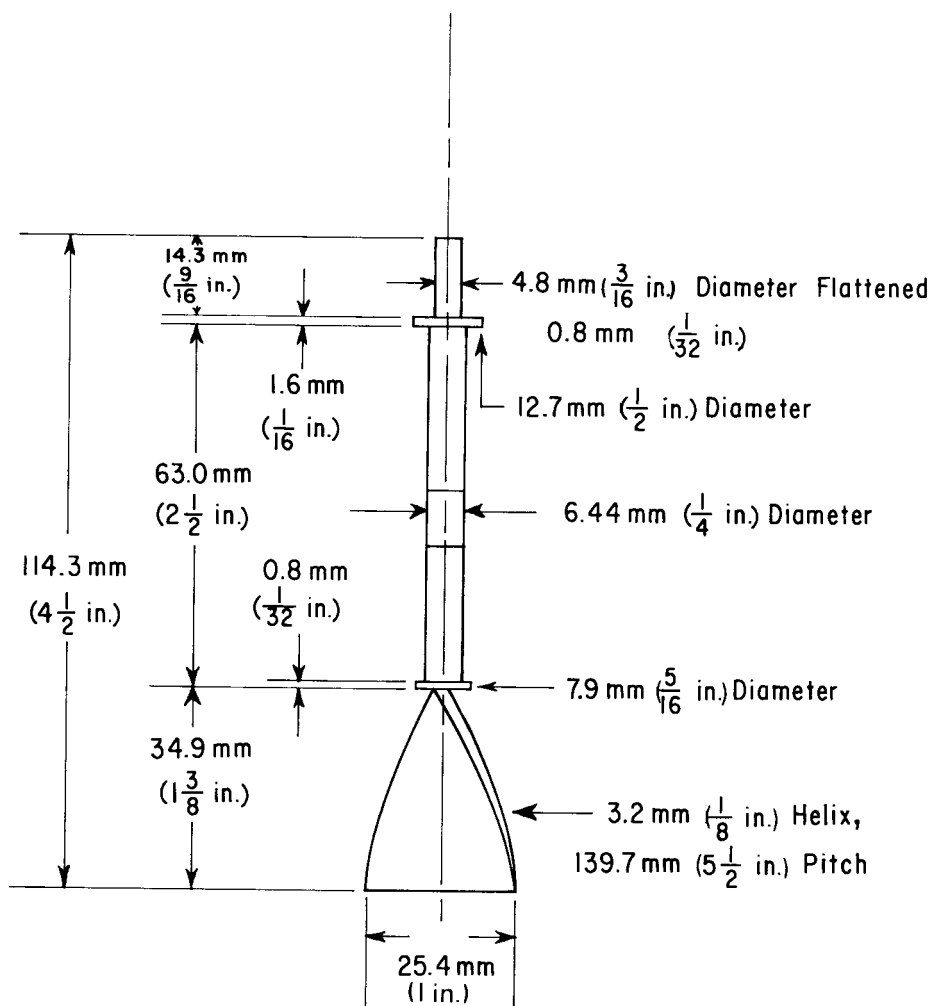

Note—All dimensions are subject to a tolerance of  $\pm 0.1$  mm ( $\pm 0.004$  in.) Material: nickel-plated brass or stainless steel.

FIG. 1 Propeller Rotor for Use with Stormer Viscometer<sup>9</sup>

## 7. Sampling

7.1 Sample the material from the original containers immediately after stirring to a uniform consistency in accordance with Practice D 140. Restir the samples to ensure uniformity immediately before withdrawing portions for individual tests.

## 8. Test Methods

8.1 *Water*—Test Method D 95.

8.2 *Nonvolatile Matter*—Weigh  $10 \pm 1$  g of coating to the nearest 0.01 g into each of two tared, flat-bottom dishes having a diameter of approximately 2.5 in. (64 mm) and walls  $\frac{5}{8}$  in. (16 mm) high. Heat the dish and contents in an oven at 320 to 330°F (160 to 166°C) until the residue shows a loss of not more than 0.05 g on successive hourly weighings. Make each weighing after cooling in a desiccator. Calculate the percent nonvolatile matter from the mass of the residue and the mass of the original sample as follows:

$$\text{Nonvolatile matter, \%} = (R_e/S) \times 100 \quad (1)$$

where:

$R_e$  = mass of residue from evaporation, g, and

$S$  = mass of original sample, g.

Record the average of the two separate determinations.

8.3 *Insoluble in CS<sub>2</sub>*—Test Method D 4. Trichloroethylene may be used in place of carbon disulfide, if desired.

8.4 *Metallic Aluminum*:

8.4.1 *Reagents*—Reagent grade chemicals or equivalent, prepared in conformance with Practice E 200, shall be used in the determination of metallic aluminum.

8.4.1.1 *Water*—Use only distilled or deionized water.

8.4.1.2 *Ferric Sulfate Solution*—Dissolve 330 g of ferric sulfate [ $\text{Fe}_2(\text{SO}_4)_3 \cdot 9\text{H}_2\text{O}$ ] in 750 cm<sup>3</sup> of water and 75 cm<sup>3</sup> of concentrated sulfuric acid (sp gr 1.84). Heat the solution and let stand 2 days to dissolve the ferric sulfate completely. Then add water to make up a total volume of 1000 cm<sup>3</sup>.

8.4.1.3 *Indicator (Diphenylamine Sulfonate Solution)*<sup>8</sup>—Dissolve 0.32 g of the barium salt of diphenylamine sulfonic acid in 100 cm<sup>3</sup> of water. Then add 0.5 g of sodium sulfate and filter off the precipitate of barium sulfate.

<sup>8</sup> Diphenylamine sulfonate can be purchased from Sargent and Co., Distillation Products Industries, Division of Eastman Kodak Co., and possibly other firms.

8.4.1.4 *Phosphoric Acid*—CP 85 % orthophosphoric acid.

8.4.1.5 *Potassium Dichromate Solution*—Prepare a 0.5 *N* solution by dissolving 24.52 g of potassium dichromate in water and making up to 1000 cm<sup>3</sup>.

8.4.1.6 *Sodium Bicarbonate Solution*—Prepare a saturated solution of sodium bicarbonate (approximately 10 %).

8.4.2 *Filtering Apparatus:*

8.4.2.1 *Gooch Crucible*, glazed inside and outside with the exception of the outside bottom surface. The approximate dimensions shall be a diameter of 44 mm at the top tapering to 36 mm at the bottom and a depth of 28 mm.

8.4.2.2 *Filter Pad*, glass-fiber 32 mm in diameter.

8.4.2.3 *Filter Flask*, heavy-wall with side tube, 500-mL capacity.

8.4.2.4 *Rubber Tubing*, of adapter for holding Gooch crucible on the filter tube.

NOTE 1—A photograph of a typical filtering assembly is shown in Fig. 2 of Test Method D 3279. The filter pads, No. 934-AH, may be purchased from almost any scientific supply house.

8.4.3 *Procedure:*

8.4.3.1 Place the Gooch crucible plus one thickness of the glass-fiber filter pad in an oven at about 225°F (107°C) for 15 min. Allow to cool in a desiccator.

8.4.3.2 Place the crucible in a 100-cm<sup>3</sup> beaker and tare weigh to the nearest 1 mg. Then add about 1 g of the well-mixed sample to the crucible and reweigh as quickly as possible to the nearest 1 mg. Add 50 cm<sup>3</sup> of benzene to the crucible and beaker, filling the crucible about three-fourths full and pouring the remainder into the beaker around the crucible. Cover and let stand 15 min. Then transfer the crucible to a suction flask and apply suction. Wash the crucible and mat twice with acetone and twice with water.

8.4.3.3 Transfer the crucible to a 500-cm<sup>3</sup> wide-mouth Erlenmeyer flask. Add 50 cm<sup>3</sup> of ferric sulfate solution and stopper the flask immediately with a rubber stopper fitted with a 50-cm<sup>3</sup> separatory funnel and with an outlet tube. Immerse the end of the outlet tube in a flask of sodium bicarbonate solution. Quickly add 50 cm<sup>3</sup> of sodium bicarbonate solution to the Erlenmeyer flask through the separatory funnel, and shake the flask gently. This produces a CO<sub>2</sub> atmosphere, which prevents oxidation of the reduced ferric iron. Keep the separatory funnel stopcock closed and the outlet tube immersed in the sodium bicarbonate solution to retain the inert CO<sub>2</sub> atmosphere. Heat the solution in the Erlenmeyer flask gently until all of the aluminum is dissolved (about 15 min), and then bring the solution to a boil for 10 min. Cool to 50 to 60°F (10 to 15°C) during the remainder of the procedure.

8.4.3.4 Add 15 cm<sup>3</sup> of phosphoric acid through the separatory funnel, followed by 50 cm<sup>3</sup> of water. Shake gently to mix thoroughly. Remove the stopper assembly, add 1 cm<sup>3</sup> of the indicator, and quickly titrate with 0.5 *N* potassium dichromate solution to a purple end point (Note 2).

$$\text{Metallic aluminum, \%} = (VN \times 0.009/S) \times 100 \quad (2)$$

where:

*V* = volume of K<sub>2</sub>Cr<sub>2</sub>O<sub>7</sub> solution, cm<sup>3</sup>,  
*N* = normality of K<sub>2</sub>Cr<sub>2</sub>O<sub>7</sub> solution, and  
*S* = sample weight, g.

NOTE 2—Reduce the rate of addition of potassium dichromate near the titration end point in order to be able to recognize the transition from green to intense purple. An excess beyond this point will produce an olive green color.

8.5 *Consistency:*

8.5.1 *Apparatus*—Use the apparatus and equipment specified in Test Method D 562, Procedure A. See also 8.5 of Specification D 2823.

8.5.2 *Procedure:*

8.5.2.1 *Type I Coating*—Thoroughly mix the sample and fill a 500-cm<sup>3</sup> (1-pt) container to within 3/4 in. (20 mm) of the top. Stir the coating carefully to remove any trapped air bubbles. Maintain the temperature of the sample and the test assembly at 77 ± 0.3°F (25 ± 0.2°C), and start the test within 1 h after filling the container. Place the container on the platform of the viscometer so that the paddle-type rotor is immersed just to the mark on its shaft, and turn the rotor through approximately 100 revolutions in 25 to 30 s before starting the test. Then determine the time required for 100 revolutions with a 100-g load in addition to the standardizing load from a running start (that is, permit the rotor to make at least 10 revolutions before timing the next 100).

8.5.2.2 *Type II or Type III Coating*—Follow the procedure in 8.5.2.1, except use the propeller-type rotor<sup>9</sup> (Fig. 1) with a 300-g load in addition to the standardizing load.

8.6 *Reflectance:*

8.6.1 Prepare two panels at least 4 by 5 in. (100 by 125 mm) by coating with a doctor blade, and allow to dry 48 h at room temperature. The wet film thickness of Type I coatings shall be 0.015 in. (0.38 mm) and Type II coatings shall be 0.020 in. (0.51 mm). Any smooth, flat substrate such as uncoated aluminum or steel may be used for the test panels. Hiding power or opacity charts, suitably supported, may also be used.

8.6.2 Measure the percent luminous reflectance of each panel (the CIE<sup>10</sup> tristimulus Y value) for CIE Source C (daylight), using an instrument that integrates diffuse and specular reflectance by means of a hollow integrating sphere,<sup>11</sup> calibrated according to the manufacturer's instructions using a Gardner Laboratory Gray-White Reflectance Standard with a CIE tristimulus Y value of 40. Take at least three readings on different areas of each panel and calculate the mean luminous reflectance for each panel. Report the luminous reflectance of the coating sample as the mean of the two panel values to the nearest 0.5 %.

8.6.3 Age approximately 300 cm<sup>3</sup> of coating in a tightly-closed 500-cm<sup>3</sup> (1-pt) container in an oven at 120 ± 3.5°F (49 ± 2°C) for 3 days. Remove from the oven, cool to room temperature, prepare two panels, and determine the luminous

<sup>9</sup> Propeller-type rotor is available from A. H. Thomas Co., P.O. Box 779, Philadelphia, PA 19105, 1974 catalog 9731-D55.

<sup>10</sup> Commission Internationale de l'Éclairage.

<sup>11</sup> There are many suitable instruments which include: Diano/Hardy Recording Spectrophotometer (formerly General Electric's Recording Spectrophotometer); Bausch & Lomb Spectronic 20, 505 and 600; Cary 14; Beckman DK2 Spectrophotometers with integrating sphere reflectance attachment; Gardner Laboratory, Inc. Model UX-2; Gardner-Reynolds Pivotal-Sphere Reflectometer; Hunter Associates Laboratories D25 Color and Color Difference meter with integrating sphere; Instrument Development Laboratories Model LS Color-Eye integrating sphere Colorimeter; Carl Zeiss Elrepho integrating sphere Colorimeter or DMC 25 Spectrophotometer; and others.

reflectance as in 8.6.2. Report the mean of the two panel values as the luminous reflectance of the sample after high-temperature shelf aging.

## 9. Precision and Bias

9.1 No data has been developed for precision and bias for the test methods in this specification.

## 10. Inspection

10.1 Inspection of the material shall be as agreed upon between the purchaser and the seller as part of the purchase contract.

## 11. Rejection and Resubmittal

11.1 Failure to conform to any of the requirements prescribed in this specification may constitute grounds for rejection.

In the case of rejection, the seller shall have the right to reinspect the rejected material and resubmit the lot after removal of those packages not conforming to the requirements.

## 12. Packaging and Package Marking

12.1 All products shall be packaged and labeled in accordance with applicable regulations. Each package shall be marked to indicate the applicable ASTM specification. Packages containing product meeting Type II shall bear a statement that the product contains asbestos.

## 13. Keywords

13.1 aluminum-pigmented; asbestos-fiber; asphalt; fibered without asbestos; non-fibered

*The American Society for Testing and Materials takes no position respecting the validity of any patent rights asserted in connection with any item mentioned in this standard. Users of this standard are expressly advised that determination of the validity of any such patent rights, and the risk of infringement of such rights, are entirely their own responsibility.*

*This standard is subject to revision at any time by the responsible technical committee and must be reviewed every five years and if not revised, either reapproved or withdrawn. Your comments are invited either for revision of this standard or for additional standards and should be addressed to ASTM Headquarters. Your comments will receive careful consideration at a meeting of the responsible technical committee, which you may attend. If you feel that your comments have not received a fair hearing you should make your views known to the ASTM Committee on Standards, 100 Barr Harbor Drive, West Conshohocken, PA 19428.*

*This standard is copyrighted by ASTM, 100 Barr Harbor Drive, West Conshohocken, PA 19428-2959, United States. Individual reprints (single or multiple copies) of this standard may be obtained by contacting ASTM at the above address or at 610-832-9585 (phone), 610-832-9555 (fax), or [service@astm.org](mailto:service@astm.org) (e-mail); or through the ASTM website (<http://www.astm.org>).*