



Designation: D 3462 – 01^{€1}

Standard Specification for Asphalt Shingles Made from Glass Felt and Surfaced with Mineral Granules¹

This standard is issued under the fixed designation D 3462; the number immediately following the designation indicates the year of original adoption or, in the case of revision, the year of last revision. A number in parentheses indicates the year of last reapproval. A superscript epsilon (ϵ) indicates an editorial change since the last revision or reapproval.

This standard has been approved for use by agencies of the Department of Defense.

^{€1} NOTE—Paragraph 8.1.11.4, Conditioning, was added in January 2002 because it was inadvertently removed in the previous edition.

1. Scope

1.1 This specification covers asphalt roofing in shingle form, composed of glass felt or felts impregnated and coated on both sides with asphalt, and surfaced on the weather side with mineral granules. This specification is designed for the evaluation of products as manufactured. The test methods, physical requirements, and minimum masses are to be measured immediately after packaging or at a reasonable time, as agreed upon between buyer and seller, after manufacture and before installation. Physical and performance requirements after application and during in-service use of the products described herein are beyond the scope of this material specification.

1.2 Shingles meeting this specification are intended to be applied with a headlap of not less than 51 mm (2 in.).

1.3 The shingles shall be supplied with a factory-applied self-sealing adhesive or be designed to be locked together during installation of the shingles.

1.4 The values stated in SI units are to be regarded as the standard.

1.5 The following safety hazards caveat pertains only to the test method described in this specification: *This standard does not purport to address all of the safety concerns, if any, associated with its use. It is the responsibility of the user of this standard to establish appropriate safety and health practices and determine the applicability of regulatory limitations prior to use.*

2. Referenced Documents

2.1 ASTM Standards:

- D 5 Test Method for Penetration of Bituminous Materials²
- D 36 Test Method for Softening Point of Bitumen (Ring-

- and-Ball Apparatus)³
- D 228 Test Methods for Asphalt Roll Roofing, Cap Sheets, and Shingles³
- D 1079 Terminology Relating to Roofing, Waterproofing, and Bituminous Materials³
- D 1370 Test Method for Contact Compatibility Between Asphaltic Materials (Oliensis Test)³
- D 1922 Test Method for Propagation Tear Resistance of Plastic Film and Thin Sheeting by Pendulum Method⁴
- D 3161 Test Method for Wind-Resistance of Asphalt Shingles (Fan-Induced Method)³
- D 4977 Test Method for Granule Adhesion to Mineral Surfaced Roofing by Abrasion³
- E 108 Test Methods for Fire Tests of Roof Coverings⁵

3. Terminology

3.1 Definitions:

- 3.1.1 For definitions of terms, see Terminology D 1079.
- 3.1.2 For testing purposes, under Test Methods D 228, glass felt shall be considered as felt.

4. Materials and Manufacture

4.1 The glass felt shall be a thin porous sheet composed predominately of fine glass fibers uniformly deposited in a nonwoven pattern. It is permitted to reinforce the glass felt with random or parallel-oriented glass yarns, or both, which are permitted to be gathered or twisted, bonded or unbonded. The felt shall contain a substantially water-insoluble binding agent.

4.2 In the process of manufacture, one or more thicknesses of glass felt shall be impregnated with an asphaltic material. When more than one thickness of felt is used, the mats shall be adhered to each other with a continuous layer of asphaltic material between adjacent felts. The nature of the asphaltic material and the thickness of the adhering layers shall ensure a firm bond between adjacent glass felts. The single felt or

¹ This specification is under the jurisdiction of ASTM Committee D08 on Roofing, Waterproofing, and Bituminous Materials and is the direct responsibility of Subcommittee D08.02 on Prepared Roofings, Shingles, and Siding Materials.

Current edition approved Aug. 10, 2001. Published November 2001. Originally published as D 3462 – 83. Last previous edition D 3462 – 00.

² Annual Book of ASTM Standards, Vol 04.03.

³ Annual Book of ASTM Standards, Vol 04.04.

⁴ Annual Book of ASTM Standards, Vol 08.01.

⁵ Annual Book of ASTM Standards, Vol 04.07.

laminated felts shall then be coated on both sides with a hot asphaltic coating.

4.3 The asphaltic material used to impregnate, laminate, and coat the glass felt, in any or all of these functions, is permitted to be compounded with a mineral stabilizer. Glass fibers are permitted to be compounded with the asphalt in addition to, or instead of, the mineral stabilizer.

4.4 The weather side shall be completely surfaced with mineral granules embedded in the asphaltic coating.

4.5 The reverse side shall be covered with a suitable material such as pulverized sand, talc, or mica to prevent the shingles from sticking together in the package.

4.6 The shingles shall have a factory-applied adhesive that will seal the shingles together after application when activated by heat and sunlight, or be designed to be locked together during installation of the shingles.

5. Physical Requirements

5.1 Shingles shall not stick together in the package so as to cause damage upon being unpacked at ambient temperatures.

5.2 The shingles shall conform to the requirements prescribed in Table 1.

5.3 *Fire Test Classification*—Shingles shall pass all of the Class A fire exposure test requirements of Test Method E 108.

5.4 *Wind Resistance*, Shingles shall pass the wind resistance test requirements of Test Method D 3161.

6. Dimensions, Masses, and Permissible Variations

6.1 The form and size of the shingles shall be as agreed upon by the purchaser and seller.

6.2 The shingles shall not vary in length or width by more than 3.2 mm ($\pm 1/8$ in.) from nominal dimensions established for each size, except that the length (long dimension) of shingles without cutouts shall not vary by more than 6.4 mm ($\pm 1/4$ in.).

6.3 The shingles shall conform to the masses prescribed in Table 2.

7. Workmanship, Finish, and Appearance

7.1 The glass felt shall be uniformly encapsulated with

asphalt and shall show no uncoated fibers. The fiber pattern may be discernible on the back side of the shingle.

7.2 The weather surface shall be uniform in finish and may be embossed to simulate a grain texture. The mineral granules shall cover the entire surface and shall be firmly embedded in the asphalt coating. The granules may project into the mat to a limited degree. There shall be no damage to the mat by penetrating granules as determined after extraction.

7.3 The finished shingles shall be free of visible defects such as holes, edges not cleanly cut, rents, cracks, or indentations.

8. Sampling and Test Methods

8.1 Sample the material in accordance with Test Methods D 228 and determine conformance to the requirements of this specification in accordance with the following test methods:

8.1.1 *Weight Loss and Behavior on Heating*—Test Methods D 228.

8.1.2 *Tear Strength*—Use Test Method D 1922 as modified here.

8.1.2.1 Specimens shall be rectangular, 76 by 63 mm (3 by 2.5 in.) ± 3 %.

8.1.2.2 Condition specimens at $23 \pm 2^\circ\text{C}$ ($73 \pm 4^\circ\text{F}$) for at least 2 h before testing and conduct tests at $23 \pm 2^\circ\text{C}$ ($73 \pm 4^\circ\text{F}$).

8.1.2.3 Each specimen will be composed of a single ply. Cut specimens from shingles in areas free of sealing resin and release tape. The 76-mm edges of the specimens shall be parallel to the long dimension (machine direction) of the shingles so that the tears will run in the short dimension (cross-machine direction) of the shingle. Enough specimens shall be prepared so that ten results can be recorded after excluding any that must be rejected as prescribed in 8.1.2.4.

8.1.2.4 Use an Elmendorf Tear Strength Tester with 3200- or 6400-g (31- to 63-N) full-scale capacity. Make all tests with granule surface of specimens facing away from knife blade. Do not reject the results from specimens that tear through a side edge as opposed to the top edge. Reject results of specimens that tear in such a way that the portion of the specimen that is

TABLE 1 Physical Requirements of Asphalt Shingles Made from Glass Felt

	max	min
<i>Behavior on heating:</i>		
Loss of volatile matter, %	1.5	...
Sliding of granular surfacing, mm (in.)	1.6 ($1/16$)	...
Tear strength, g	...	16.7 N (1700)
Fastener pull-through resistance at $23 \pm 2^\circ\text{C}$ ($73 \pm 4^\circ\text{F}$), newtons (lbf)		
Single-ply product	...	90 (20)
Multi-ply product	...	135 (30)
Fastener pull-through resistance at $0 \pm 2^\circ\text{C}$ ($32 \pm 4^\circ\text{F}$), newtons (lbf)		
Single-ply product	...	104 (23)
Multi-ply product	...	180 (40)
Wind resistance	...	pass
Fire resistance	...	Class A
Penetration of asphalt, 0.1 mm^A (tested without mineral stabilizer)	...	15
Pliability at $23 \pm 2^\circ\text{C}$ ($73 \pm 4^\circ\text{F}$)		
Weather side up machine direction	...	4 of 5 shall pass
Weather side up cross direction	...	4 of 5 shall pass
Weather side down machine direction	...	4 of 5 shall pass
Weather side down cross direction	...	4 of 5 shall pass
Asphalt softening point, $^\circ\text{C}$ ($^\circ\text{F}$) ^A (tested without mineral stabilizer)	113 (235)	88 (190)
Compatibility of factory-applied, self-sealing adhesive and asphaltic coating at 66°C (150°F), mm^A	0.5	...
Weight of displaced granules	1.0 g	...

^AThe requirements are to be tested for by the manufacturer of the shingles. They cannot be determined on the finished product.

TABLE 2 Masses of Asphalt Shingles Made from Glass Felt

	max	min
Minimum net mass per area of shingles (individual bundle), g/m ² (lb/100 ft ²)	...	3418 (70.0)
Average net mass per area of shingles (total sample), g/m ² (lb/100 ft ²)	...	3564 (73.0)
Mass per area of mat, g/m ² (lb/100 ft ²)	...	65.9 (1.35)
Mass per area of asphalt, g/m ² (lb/100 ft ²)	...	732 (15.0)
Mass per area of mineral matter passing a No. 6 (3.35-mm) sieve and retained on a No. 70 (212-μm) sieve, g/m ² (lb/100 ft ²) ^A	...	1221 (25.0)
Mass percent of mineral matter passing a No. 70 (212-μm) sieve based on the total asphalt and mineral matter passing the No. 70 (212-μm) sieve	70.0	...

^AAt least 55 mass % of this mineral matter shall be retained on a No. 20 (850-μm) sieve and not more than 5 % shall pass a No. 40 (425-μm) sieve.

in the stationary jaw rubs against the pendulum.

8.1.2.5 Report the average tear resistance of ten specimens to the nearest 10 g (0.1 N).

8.1.2.6 The following criteria shall be used to judge the acceptability of the results at the 95 % confidence level:

(1) *Repeatability*—Duplicate results by the same operator should be considered suspect if they differ by more than 17 %.

(2) *Reproducibility*—The results submitted by each of two laboratories should be considered suspect if they differ by more than 28 %.

8.1.3 *Fire Test Classification*—Test Method E 108, Class A tests.

8.1.4 *Wind Resistance*—Test Method D 3161.

8.1.5 *Penetration of Asphalt*—Test Method D 5.

8.1.6 *Asphalt Softening Point*—Test Method D 36.

8.1.7 *Compatibility*—Test Method D 1370.

8.1.8 *Minimum Net Mass and Average Net Mass*—Test Methods D 228.

8.1.9 *Mass of Glass Mat, Asphalt, and Mineral Matter*—Test Methods D 228.

8.1.10 *Weight of Displaced Granules*—Test Method D 4977.

8.1.11 *Fastener Pull-Through Resistance*:

8.1.11.1 *Scope*—This test method measures the force required to pull a fastener head through a specimen of shingle material under defined conditions in a specified test apparatus. The test provides a simple measurement of complex mechanical effects which relate to the shingle's resistance to wind.

8.1.11.2 *Fasteners*—Various fasteners appropriate for application of shingles shall be permitted in this test. A standard galvanized roofing nail with 9.5-mm (3/8-in.) diameter head, is used in the following procedure. The specific fastener employed must be reported with the results and, if necessary, the orientation of any prominent geometric features with respect to the shingle orientation shall also be reported.

NOTE 1—When other fasteners, for example staples, are used with this test procedure and apparatus, the effects of varying orientation of the staple crown with the shingle orientation (lengthwise or at some angle to the length direction of the shingle), or the effects of the staple crown not being parallel to the shingle surface, will generally cause greater variability in the results than when using a roofing nail.

8.1.11.3 *Specimens*—For single-ply shingles, prepare ten specimens 98 ± 3 mm (3 7/8 ± 1/8 in.) square for each sample or shingle material to be tested at each test condition. Each specimen shall be composed of a single thickness of shingle. Specimens shall be permitted to include areas containing sealant (factory-applied adhesive) or release tape, or both, if this is expected to be in the nailing area when the shingles are applied in accordance with the manufacturers'/sellers' instruc-

tions. If this is the case, then it shall be noted in the report since it could affect the result. For normal testing, the central area of the specimen where the nail penetrates shall be typical of the single thickness exposed area of the shingle under test. For shingles with tab cutouts, any specimen in which the cutout is visible through the opening in the plate (see 8.1.11.6(2)) will have the effect of increasing the variability of the results.

NOTE 2—Specimens shall be permitted to include areas containing sealant (factory-applied adhesive) or release tape, or both, if this is expected to be in the nailing area when the shingles are applied in accordance with the manufacturers'/sellers' instructions. If this is the case, then it shall be noted in the report since it could affect the result. For normal testing, the central area of the specimen where the nail penetrates shall be typical of the single thickness exposed area of the shingle under test. For laminated shingles, it is possible to obtain useful information by performing the test through the double thickness area of the shingle. When this is done, it shall be noted in the report as an exception to the standard procedure.

8.1.11.4 *Conditioning*—Condition specimens at the temperatures prescribed in Table 1 for at least 2 h before testing and conduct the test at the prescribed temperatures. Other test conditions shall be permitted to give indications of fastener pull-through resistance at different temperatures, provided that the specimens are conditioned for at least 2 h and tested at the desired temperature, and that the temperature used is noted in the report.

8.1.11.5 For multi-ply shingles, prepare ten specimens 98 ± 3 mm (3 7/8 ± 1/8 in.) square using the following procedure. These specimens shall be cut from the manufacturers' specified fastening position on the shingle. First determine the manufacturers' specific defined fastener placement position on the shingle. This may be found in the written instructions or by a drawing showing the specific fastening points on the shingle wrapper. Once this position is determined, cut a 98- ± 3-mm (3 7/8- ± 1/8-in.) wide strip from the shingle with this fastening position centered in the strip. Typically, this strip will be cut from the long dimension, or length, of the shingle. Use this strip to cut consecutive specimens 98 ± 3 mm (3 7/8 ± 1/8 in.) in length. No less than three specimens in a row or more than four specimens in a row from one shingle can be used to make up the ten specimens required for testing.

(1) Specimens shall be permitted to include areas containing sealant (factory-applied adhesive) or release tape, or both, if this is expected to be in the nailing area when the shingles are applied in accordance with the manufacturers'/sellers' instructions. If this is the case, then it shall be noted in the report since it could affect the results.

8.1.11.6 *Procedure*—Push a 38-mm (1 1/2-in.) long galvanized roofing nail with 9.5-mm (3/8-in.) diameter head through

the center of the specimen (entering from the granule side and exiting at the backsurfacing side as in normal shingle application) such that the head of the nail rests against the granule surface and the shank protrudes from the backsurface. It is permitted to use a fixture to locate the center of the specimen within ± 6 mm ($\pm 1/4$ in.) of the intersection of the diagonals of the square specimen or to draw diagonals with chalk to facilitate central positioning of the nail.

(1) Clamp the base part of the apparatus shown in Fig. 1 into the lower jaws of a constant rate of extension test machine capable of applying a force of at least 445 N (100 lbf) at an extension rate of 100 mm (4 in.)/min.

(2) Place the plate part of the apparatus shown in Fig. 1 over the specimen so that the plate is centered over the specimen in contact with the backsurface of the specimen and with the nail shank protruding through the center of the 63.5-mm (2 1/2-in.) diameter hole. Use a different nail for each specimen to prepare a number of specimens, with nails in position, ready for conditioning before testing.

(3) Place the assembled specimen, nail, and plate into the base part of the apparatus with the nail pointing upwards so that it can be gripped by the upper jaw of the test machine. The arrangement of the assembly ready for test is shown in Fig. 2.

(4) Clamp the nail shank in the upper jaw of the test machine and pull the nail through the specimen at a rate of 100 mm (4 in.)/min. Record the maximum force in N (lbf) to the nearest 0.5 N (0.1 lbf) required to pull the head of the nail completely through the specimen. If a strip-chart recorder is used, choose a scale in which the maximum pull-through force is at least 50 % of the full-scale reading.

8.1.11.7 *Report*—Report the type of product: single-ply or multi-ply along with the number of plies. Report the average and standard deviation of the pull-through force for the ten specimens from each sample of shingles tested. Report the test

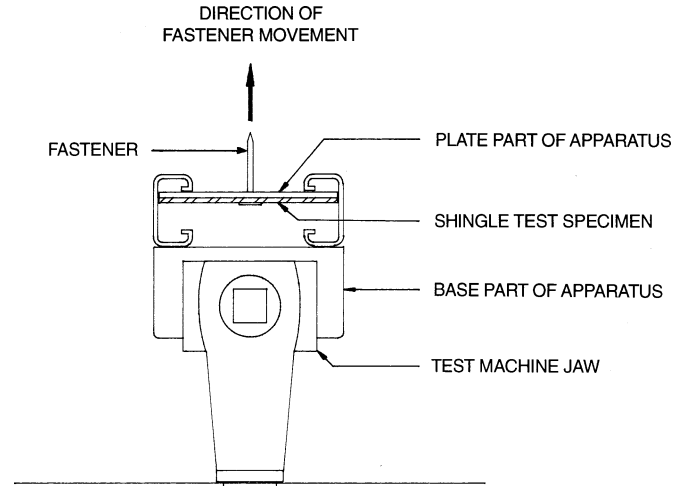

FIG. 2 Apparatus

conditions and note any special circumstances, for example, if the pull-through was performed in an area containing sealant or release tape, or both. Report also the type of fastener used in the test.

8.1.11.8 *Precision and Bias*—The following criteria shall be used to judge the acceptability of results at the 95 % confidence level:

(1) *Repeatability*:

(a) *Single-Ply Shingles*—Duplicate results by the same operator on the same sample shall be considered suspect if they differ by more than 15 %.

(b) *Multi-Ply Shingles*—Duplicate results by the same operator on the same sample shall be considered suspect if they differ by more than 15 %.

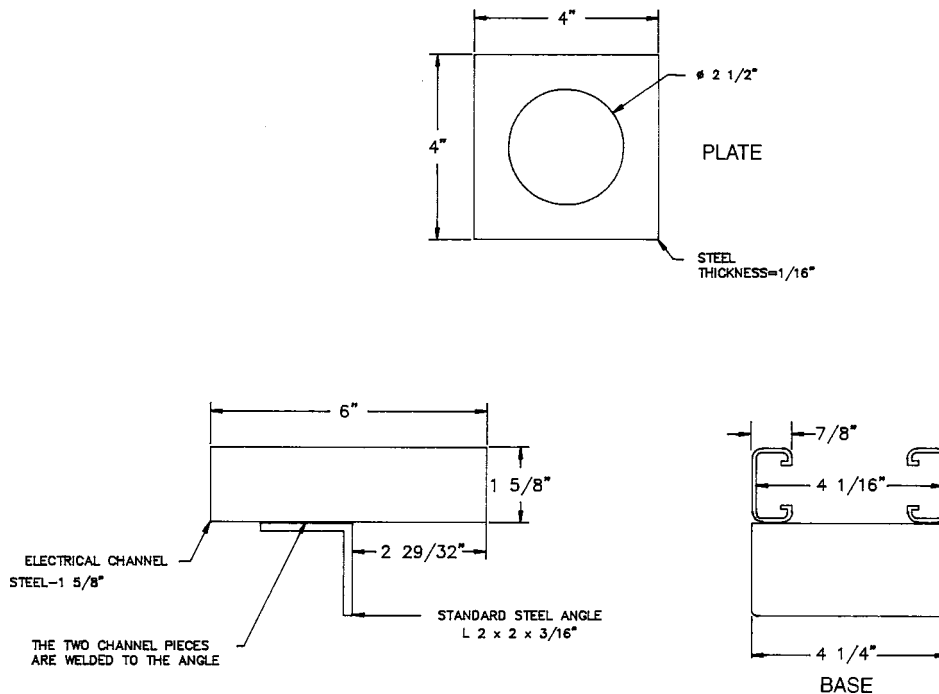

FIG. 1 Base and Plate Parts of Apparatus

(2) *Reproducibility*:

(a) *Single-Ply Shingles*—The results submitted by each of two laboratories shall be considered suspect if they differ by more than 20 %.

(b) *Multi-Ply Shingles*—The results submitted by each of two laboratories shall be considered suspect if they differ by more than 25 %.

(3) *Bias*—The procedure in 8.1.11.7 for measuring fastener pull-through resistance has no bias because the value of the pull-through is defined only in terms of this method.

8.1.12 *Pliability*:

8.1.12.1 *Scope*—This procedure measures the pliability of specimens of shingle material by bending through an angle of 90° under defined conditions. Pliability is assessed as the specimens' resistance to formation of surface fissures or to fracture.

8.1.12.2 *Significance and Use*—This test measures the pliability of shingles in the as-manufactured condition.

8.1.12.3 *Apparatus*—A block is required over which the test specimens are bent after conditioning as set forth in 8.1.12.5. The block shall be a cube of approximately 150 mm (6 in.) sides with one edge rounded to a radius of 25 mm (1 in.).

8.1.12.4 *Specimens*—Prepare two sets of test specimens. A set is defined as five specimens cut with their long dimension parallel to the length of the shingle (machine direction) and five specimens cut with their long dimension perpendicular to the length of the shingle (cross machine direction). Each specimen shall be 25 ± 3 mm ($1 \pm \frac{1}{8}$ in.) in width and 150 ± 3 mm ($6 \pm \frac{1}{8}$ in.) in length. All specimens shall be cut from the portion of the shingle intended for exposure when the shingle is properly applied. For laminated and overlay-type shingles, cut the specimens from the single-thickness areas of the shingle. When shingle design does not permit cutting the specified length, then a shorter specimen is permitted, provided that it is at least 100 mm (4 in.) long and of the specified width.

8.1.12.5 *Conditioning*—Condition the specimens and the block at $23 \pm 2^\circ\text{C}$ ($73 \pm 4^\circ\text{F}$) for 2 ± 0.1 h and perform the test at $23 \pm 2^\circ\text{C}$ ($73 \pm 4^\circ\text{F}$).

NOTE 3—Other test conditions shall be permitted to give indications of pliability at different temperatures, provided that the specimens and the block are conditioned for 2 ± 0.1 h and tested at the selected temperature, and that the temperature used is noted in the report. An appropriate enclosure will be required when testing at temperatures other than ambient.

8.1.12.6 *Procedure*—Bend one set of specimens with the weather side up and one set with the weather side down, at a uniform speed through an angle of 90° in $2 \pm \frac{1}{2}$ s over the rounded edge of the block. When bending, hold the specimens by hand tightly against the upper face of the block, so that the projecting end of the specimen is perpendicular to the rounded edge. Bend the projecting end of the specimen over the rounded edge without exerting any force other than that

required to keep the specimen in contact with the block and to avoid kinking. Maintain the block and specimens at the conditioning/test temperature during the test. Hold the specimen against the block so that contact is made with the entire curved surface during bending and that the two ends of the specimen are at 90° to each other at the end of the test.

8.1.12.7 *Failure*—Failure of a specimen in this test is defined as cracking of the filled coating asphalt which exposes the reinforcement of the shingle. The cracking shall be visible to the naked eye when the specimen is viewed in the bent condition on the mandrel block and shall not include separation of granules or other superficial fissures which do not extend through the filled coating asphalt surface to the reinforcement. Fracture through the specimen is considered a failure.

8.1.12.8 *Report*—Report the nature of the sample, the sampling procedure, the conditioning/test temperature, and the number of specimens passing the pliability test.

8.1.12.9 *Precision and Bias*—No statement is made about the precision of the procedure in 8.1.12.6 for measuring pliability since the results merely state whether there is conformance to the criteria specified in the procedure. This method of measuring pliability is biased against thicker shingles because the stress experienced in the surface of the specimen as they are bent over the mandrel increases as the thickness of the specimen increases. The method becomes a more severe test as the thickness of the shingle increases.

9. Inspection

9.1 Inspection of material shall be made as agreed upon between the purchaser and the seller as part of the purchase contract.

10. Rejection and Resubmission

10.1 Failure to conform to any one of the requirements prescribed in this specification shall constitute grounds for rejection. In case of rejection, the seller shall have the right to reinspect the rejected shipment and resubmit the lot after removal of those packages not conforming to the specified requirement.

11. Packaging, Marking, and Shipping

11.1 The shingles shall be packed for shipment to ensure acceptance by common carrier for interstate transportation and to afford adequate protection from normal hazards of handling.

11.2 Unless otherwise agreed upon between the supplier and the purchaser, each product package shall be marked plainly with the supplier's name, product brand, the area of the roof surface covered, ASTM designation, style, and color of the product.

12. Keywords

12.1 asphalt shingles; fiber glass shingles; glass felt; performance tests



D 3462

ASTM International takes no position respecting the validity of any patent rights asserted in connection with any item mentioned in this standard. Users of this standard are expressly advised that determination of the validity of any such patent rights, and the risk of infringement of such rights, are entirely their own responsibility.

This standard is subject to revision at any time by the responsible technical committee and must be reviewed every five years and if not revised, either reapproved or withdrawn. Your comments are invited either for revision of this standard or for additional standards and should be addressed to ASTM International Headquarters. Your comments will receive careful consideration at a meeting of the responsible technical committee, which you may attend. If you feel that your comments have not received a fair hearing you should make your views known to the ASTM Committee on Standards, at the address shown below.

This standard is copyrighted by ASTM International, 100 Barr Harbor Drive, PO Box C700, West Conshohocken, PA 19428-2959, United States. Individual reprints (single or multiple copies) of this standard may be obtained by contacting ASTM at the above address or at 610-832-9585 (phone), 610-832-9555 (fax), or service@astm.org (e-mail); or through the ASTM website (www.astm.org).