



Designation: D 3746 – 85 (Reapproved 1996)^{ε1}

AMERICAN SOCIETY FOR TESTING AND MATERIALS
100 Barr Harbor Dr., West Conshohocken, PA 19428
Reprinted from the Annual Book of ASTM Standards. Copyright ASTM

Standard Test Method for Impact Resistance of Bituminous Roofing Systems¹

This standard is issued under the fixed designation D 3746; the number immediately following the designation indicates the year of original adoption or, in the case of revision, the year of last revision. A number in parentheses indicates the year of last reapproval. A superscript epsilon (ϵ) indicates an editorial change since the last revision or reapproval.

^{ε1} NOTE—Editorial changes were made throughout in July 1996.

1. Scope

1.1 This test method covers the determination of the resistance of bituminous roofing systems to impact loads at any desired temperature, with a missile of the weight, size, and shape specified herein.

1.2 The values stated in SI units are to be regarded as the standard. The values given in parentheses are for information only.

1.3 *This standard does not purport to address all of the safety concerns, if any, associated with its use. It is the responsibility of the user of this standard to establish appropriate safety and health practices and determine the applicability of regulatory limitations prior to use.* For specific precautionary statements, see Section 6.

2. Referenced Documents

2.1 ASTM Standards:

D 2829 Practice for Sampling and Analysis of Built-Up Roofs²

3. Summary of Test Method

3.1 This test method subjects 305 by 305-mm (12 by 12-in.) specimens of a roofing system (insulation and membrane complete with top surfacing) to a series of four impacts, one in each quadrant, from a standard missile falling freely from a predetermined height with an impact energy of 30.0 J (22 lbf-ft). Damage to the membrane is assessed by visual examination of the felts after solvent extraction of the bitumen.

3.2 The effect of specimen temperature on impact resistance can be studied by running the test in an environmental chamber at any desired temperature.

4. Significance and Use

4.1 This test method provides a means of evaluating roofing systems for resistance to impact loads of many kinds. It should also be useful in developing performance criteria for roofing systems.

5. Apparatus

5.1 *Vertical Guide Tube*, 1.22 m (4.0 ft) long by 60 mm ($2\frac{3}{8}$ in.) in inside diameter, suitably positioned over a 610-mm (24-in.) square, horizontal test table constructed of wood 2 by 4s on edge, through-bolted and fitted with a centering jig to assure proper alignment of the specimen beneath the guide tube (see Fig. 1). The guide tube is adjustable in height to accommodate differing specimen thicknesses and maintain constant missile impact energy. Provision is made at the top of the guide tube to support the missile during alignment of the specimen, and for instantaneous release of the missile to free-fall within the guide tube until contact is made with the specimen. Gravel screens are attached to the edges of the test table to retain any loose gravel that might fly from the impact area.

5.2 *Missile* (see Fig. 2), consisting of a steel cylinder 50 mm (2 in.) in diameter by 150 mm (6 in.) long, with a case-hardened hemispherical head. The mass of the missile is adjusted to 2.27 kg (5.0 lb) by the addition of lead shot to a cavity machined into the cylindrical portion and sealed with a screw cap.

6. Safety Precautions

6.1 Employ suitable devices for eye protection when carrying out steps in 10.1-10.7.3.

6.2 Use a fume hood when extracting specimens with 1,1,1 trichloroethane or xylene in 10.7.3. Trichloroethane and xylene are toxic and good ventilation should be provided.

7. Sampling

7.1 *Field Samples*—Cut test specimens directly from an actual roof, following the instructions in 8.1. Package each specimen separately in a sealed plastic bag.

7.2 Laboratory Samples:

7.2.1 Condition all components at 50 ± 5 % relative humidity and $25 \pm 1^\circ\text{C}$ ($77 \pm 2^\circ\text{F}$) for 24 h prior to constructing the sample membrane.

7.2.2 Prepare sample membranes at least 0.90 by 1.20 m (3 by 4 ft) as required by the roofing system specification being tested, including insulation and top surfacing. The quantity of material in each layer of the membrane shall be within 10 % of that specified and the entire sample shall be within 5 %.

8. Test Specimens

8.1 Test specimens may be taken directly from an actual

¹ This test method is under the jurisdiction of ASTM Committee D-8 on Roofing, Waterproofing, and Bituminous Materials and is the direct responsibility of Subcommittee D08.20 on Roof Membrane Systems.

Current edition approved Sept. 27, 1985. Published November 1985. Originally published as D 3746 – 78. Last previous edition D 3746 – 78.

² *Annual Book of ASTM Standards*, Vol 04.04.

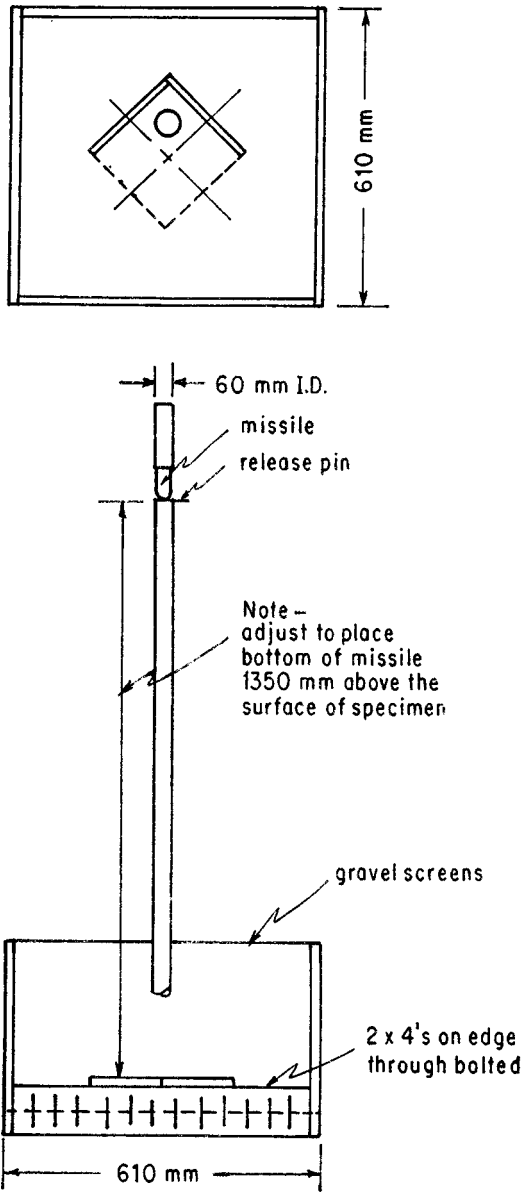

FIG. 1 Guide Tube, Test Table, and Centering Jig

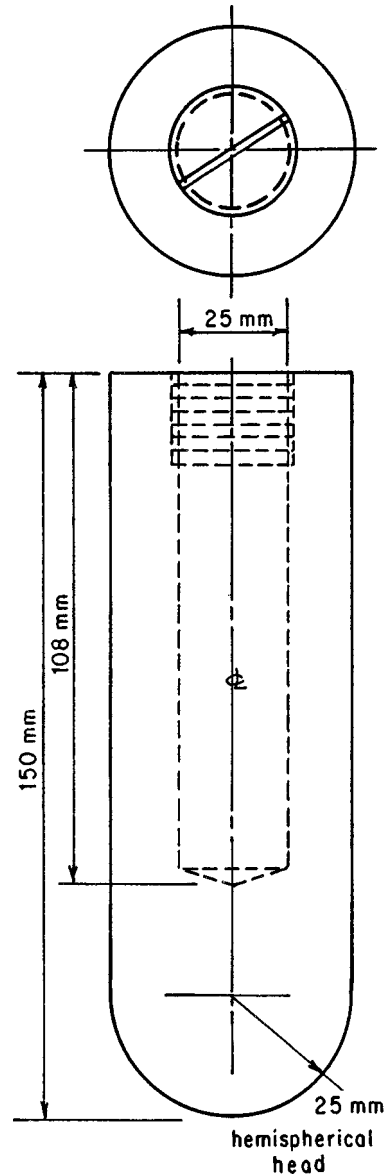

FIG. 2 Steel Missile

roof or cut from a laboratory-prepared sample using a 305 by 305-mm (12 by 12-in.) metal template as described in Recommended Practice D 2829, and shall include all of the aggregate and insulation in the area of the specimen. Any loose aggregate must be distributed evenly over the surface of the specimen prior to testing.

NOTE 1—When the roofing system specimen contains roof insulation, it is recommended that a buffer strip be removed around the metal template area prior to removal of the specimen in order to reduce damage to the insulation. The buffer zone should be a “V” type wedge extending to the bottom of the specimen thickness to be removed for testing. The inside top of the “V” wedge area should be the edge of the metal template. It is normally 75 to 100 mm (3 to 4 in.) wide. Pressure is normally applied to the template to keep it from moving while cutting the “V” wedge.

9. Conditioning

9.1 Condition the apparatus and all specimens at the desired temperature for a minimum of 8 h prior to testing.

10. Procedure

10.1 Place the test specimen in position beneath the guide tube so the missile will strike the center of one quadrant.

10.2 Place the missile in the top of the guide tube supported by the instantaneous release mechanism.

10.3 Adjust the height of the guide tube so the bottom of the missile is 1350 mm (53 in.) above the surface of the specimen and lock the guide tube in position.

10.4 Release the missile, allowing it to fall and strike the specimen.

10.5 Return the missile to its support in the top of the guide tube, and rotate the specimen 90° to center the second quadrant beneath the guide tube.

10.6 Repeat 10.4 and 10.5 until all four quadrants of the specimen have been subjected to impact.

10.7 *Damage Assessment:*

10.7.1 Remove any slag or gravel surfacing from the specimen carefully with a hot scraper, such as a putty knife.

10.7.2 Record the extent of obvious damage to the membrane, such as dents or fractures, by photograph or sketch and written description.

10.7.3 Cut the four impact areas from the specimen using a hot knife. Staple the felts in each area together and extract the bitumen by immersing in warm 1,1,1 trichloroethane in a fume hood. *Do not heat the trichloroethane to boiling.* (For tarred felt and pitch membranes, use xylene in place of trichloroethane.)

10.8 *Rating of Impact Damage:*

10.8.1 Rate the impact damage which occurs in each ply in each of the four quadrants by assigning the number which most accurately describes the impact damage, as follows:

0 = no damage;

2 = dents, indentations only;

4 = any cracks or splits

10.8.2 After assigning the numbers to all plies within each quadrant, add up all the numbers and divide by four times the number of plies to obtain an average for the membrane.

11. Report

11.1 The report shall include the following:

The American Society for Testing and Materials takes no position respecting the validity of any patent rights asserted in connection with any item mentioned in this standard. Users of this standard are expressly advised that determination of the validity of any such patent rights, and the risk of infringement of such rights, are entirely their own responsibility.

This standard is subject to revision at any time by the responsible technical committee and must be reviewed every five years and if not revised, either reapproved or withdrawn. Your comments are invited either for revision of this standard or for additional standards and should be addressed to ASTM Headquarters. Your comments will receive careful consideration at a meeting of the responsible technical committee, which you may attend. If you feel that your comments have not received a fair hearing you should make your views known to the ASTM Committee on Standards, 100 Barr Harbor Drive, West Conshohocken, PA 19428.

11.1.1 Source and type of all materials employed in the sample roofs,

11.1.2 Complete description of the construction tested,

11.1.3 Age of the specimens,

11.1.4 Test temperature,

11.1.5 Average damage incurred over the four impacts defined by means of a pictorial representation and a written description,

11.1.6 Overall numerical average which rates the membrane's impact damage in the specific system tested, and

11.1.7 Date of test and operator's signature.

12. Precision and Bias

12.1 No statement is made about either the precision or the bias of this test method since the result merely indicates the rating of impact damage by this procedure.

13. Keywords

13.1 impact; loads; missile; resistance; roofing systems; temperature