



Standard Test Method for Hydrostatic Pressure Resistance of Waterproofing Membranes¹

This standard is issued under the fixed designation D 5385; the number immediately following the designation indicates the year of original adoption or, in the case of revision, the year of last revision. A number in parentheses indicates the year of last reapproval. A superscript epsilon (ϵ) indicates an editorial change since the last revision or reapproval.

^{e1} NOTE—Editorially switched from English dominant to SI dominant.

1. Scope

1.1 This test method measures the hydrostatic resistance of a waterproofing membrane under controlled laboratory conditions. This test method is not suitable for systems that rely on confinement of the seams by the backfill since backfill is not part of this test method.

1.2 The primary units in this test method are SI; inch-pounds units are shown in parentheses.

1.3 *This standard does not purport to address all of the safety problems, if any, associated with its use. It is the responsibility of the user of this standard to establish appropriate safety and health practices and determine the applicability of regulatory limitations prior to use.*

2. Terminology

2.1 Definition:

2.1.1 *post-formed crack*—for the purposes of this test method, one that forms and widens behind the waterproofing membrane after it has been applied and cured.

3. Significance and Use

3.1 This test method tests the hydrostatic resistance of a waterproofing membrane and can be used to compare the hydrostatic resistance of waterproofing membranes.

3.2 No correlation has been established between the performance in this test method and that in the field.

4. Apparatus

4.1 *Hydrostatic Testing Equipment*, including a chamber (Fig. 1), and a clamping bracket (Fig. 2), and the gasket and fasteners to form the completed assembly (Fig. 3).

4.2 *Conditioning Room*, with forced air circulation to maintain a temperature of 2 to 7°C (35 to 45°F) for testing sheet systems, 18 to 24°C (65 to 75°F) for liquid-applied systems, and large enough to condition, prepare, and test samples.

4.3 *Source of Compressed Air*, with pressure up to 690 kPa (100 psi) and with an air pressure controller to regulate the air in 103-kPa (15-psi) increments.

4.4 *Cut Off Saw*, equipped with a diamond or masonry blade, to prepare precast concrete blocks for testing substrates.

4.5 *Clock*—Either a common time piece or a 1-h interval timer.

4.6 *Silicone Vacuum Grease*.

4.7 *Precast-Concrete Patio Blocks*, 125-lb/ft³ minimum density, 2100-psi minimum compressive strength, smooth surfaced, 191 by 394 by 51 mm (7½ by 15½ by 2 in.).

5. Test Substrate Preparation

5.1 Cut an approximately 3.2-mm (¼-in.) wide kerf 44 mm (1¾ in.) deep lengthwise down the center of a 191 by 394 by 51-mm (7½ by 15½ by 2-in.) concrete block.

5.2 Cut a kerf in at least three blocks for each system to be tested, and condition the blocks at the test temperature for at least 24 h.

5.3 Condition all other materials necessary for the system to be tested at the test temperature for at least 4 h.

6. Sample Preparation

6.1 Prime, surface condition, or otherwise prepare the surface of the block to receive the membrane, as recommended by the manufacturer of the system. Permit the primer to dry or cure for the minimum time recommended by the manufacturer.

6.2 For single-ply sheet samples, cut and install the membrane over the prepared block, with a lap of the width recommended by the manufacturer perpendicular to and in the center of the kerf in the other side of the blocks. The edges of the lapped sheets should extend beyond the block edges approximately 6 mm (¼ in.). Roll membranes intended for pressure-sensitive application with four passes of a 12.7-kg (28-lb), 152-mm (6-in.) wide steel roller.

6.3 Follow the manufacturer's instructions for all membranes. Spacers may be used to aid in obtaining the thickness required by the manufacturer.

¹ This test method is under the jurisdiction of ASTM Committee D08 on Roofing, Waterproofing, and Bituminous Materials and is the direct responsibility of Subcommittee D08.22 on Waterproofing and Dampproofing Systems.

Current edition approved May 15, 1993. Published July 1993.

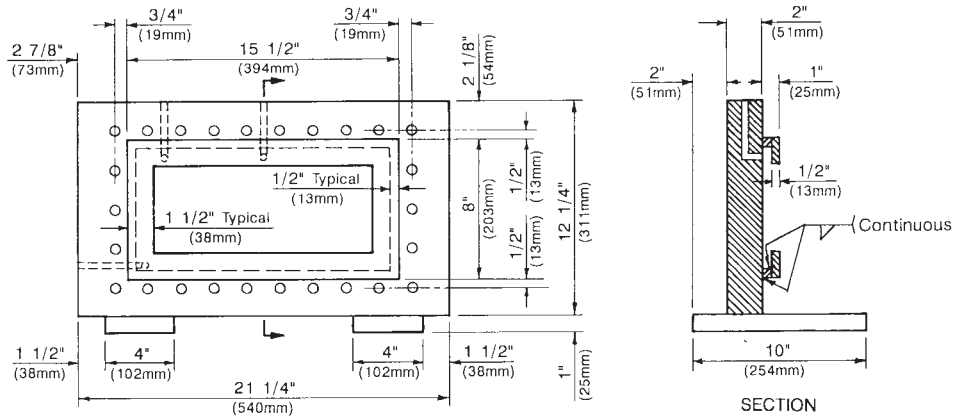

FIG. 1 Chamber

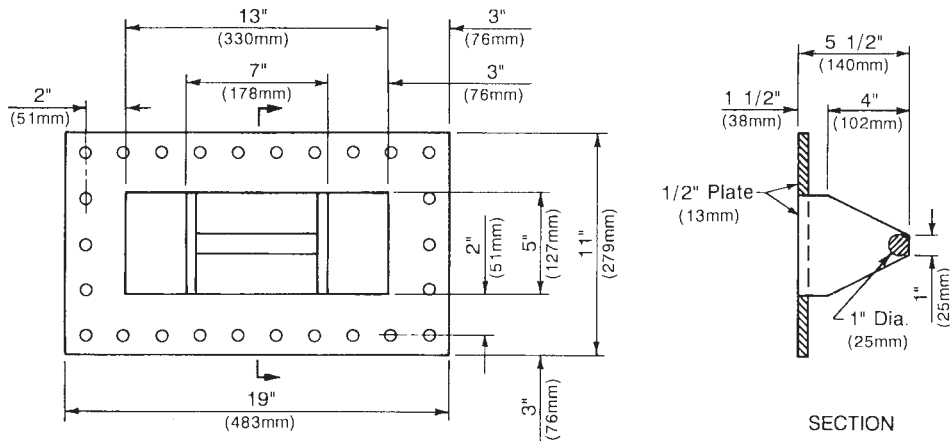

FIG. 2 Clamping Bracket

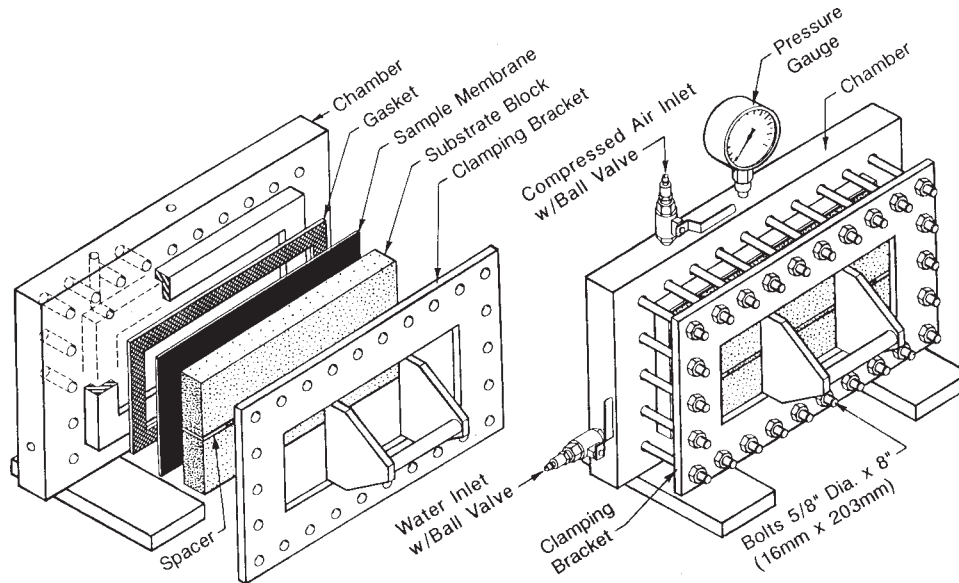

FIG. 3 Completed Assembly

6.4 Allow all samples to cure or condition for at least 24 h or for the minimum time recommended by the manufacturer, whichever is greater.

7. Procedure

7.1 Mount the test specimens using the following steps:

7.1.1 Measure the width of the kerf in the block. Obtain two 38 by 38-mm (1½ by 1½-in.) metal spacers 3.2-mm (⅛-in.) thicker than the width of the kerf.

7.1.2 With the waterproofed surface down, support the block at both ends directly under the kerf. (A pair of the nuts used to secure the sample to the chamber have proved to be adequate supports.) Tap the block with a hammer to break the balance of the block at the kerf.

7.1.3 Insert the spacers selected in 7.1.1 at each end of the kerf, and rotate the blocks to hold the spacers firmly.

7.1.4 Coat both sides of the rubber gasket lightly with vacuum grease, and fit the gasket to the face of the test chamber.

7.1.5 Set the membrane side of the block against the gasket and the steel bracket against the back of the block.

7.1.6 Tighten the fasteners clamping the block to the chamber gradually, forcing the spacers to widen the joint behind the membrane (since the spacers are 3.2 mm (⅛ in.) wider than the saw kerf).

7.2 Test the assembly as follows:

7.2.1 With the air vent open, fill the chamber with water, and close the water valve. Monitor the assembly for leaks for 30 min. Stop gasket leaks by tightening the perimeter fasteners. Record failure at 0 kPa (0 psi) if leakage is through the joints between the blocks.

7.2.2 Attach the air line, and increase the air pressure in 103-kPa (15-psi) steps each hour, up to a maximum of 690 kPa (100 psi); the last upward pressure step is 69 kPa (10 psi). If a

leak through the joint in the blocks is observed, record the pressure during the prior hour as the maximum pressure and discontinue the test.

7.2.3 If the gasket has substantial leaks, the test is invalid and a new assembly should be prepared and tested.

7.2.4 Allow the test to continue for 1 h at 690 kPa (100 psi). If the air pressure has fallen below 552 kPa (80 psi) at the end of the hour due to equipment failure, the test is invalid. Repeat the test with a new prepared sample.

8. Report

8.1 Calculate the head of water from the pressure the sample withstood successfully by multiplying the maximum pressure withstood for at least 1 h by a suitable factor. Multiply psi by 2.31 to convert the pressure to feet of water, or multiply kPa by 0.10 to convert pressure to metres of water.

8.2 Report the source and thickness of the sample, the mean and standard deviation of the head of water withstood successfully, and all pertinent observations.

9. Precision Bias

9.1 No statement is made concerning either the precision or bias of this test method since the result states merely that the system tested passes this test at a specific pressure and does not leak water for 1 h.

10. Keywords

10.1 hydrostatic pressure resistance; membrane; waterproofing

ASTM International takes no position respecting the validity of any patent rights asserted in connection with any item mentioned in this standard. Users of this standard are expressly advised that determination of the validity of any such patent rights, and the risk of infringement of such rights, are entirely their own responsibility.

This standard is subject to revision at any time by the responsible technical committee and must be reviewed every five years and if not revised, either reapproved or withdrawn. Your comments are invited either for revision of this standard or for additional standards and should be addressed to ASTM International Headquarters. Your comments will receive careful consideration at a meeting of the responsible technical committee, which you may attend. If you feel that your comments have not received a fair hearing you should make your views known to the ASTM Committee on Standards, at the address shown below.

This standard is copyrighted by ASTM International, 100 Barr Harbor Drive, PO Box C700, West Conshohocken, PA 19428-2959, United States. Individual reprints (single or multiple copies) of this standard may be obtained by contacting ASTM at the above address or at 610-832-9585 (phone), 610-832-9555 (fax), or service@astm.org (e-mail); or through the ASTM website (www.astm.org).