



Designation: D 6381 – 03a

## Standard Test Method for Measurement of Asphalt Shingle Mechanical Uplift Resistance<sup>1</sup>

This standard is issued under the fixed designation D 6381; the number immediately following the designation indicates the year of original adoption or, in the case of revision, the year of last revision. A number in parentheses indicates the year of last reapproval. A superscript epsilon ( $\epsilon$ ) indicates an editorial change since the last revision or reapproval.

### 1. Scope

1.1 This test method covers measuring the uplift resistance of asphalt roofing shingles by mechanical means. It is applicable to shingles that use a factory-applied or field-applied sealant.

1.2 There are several types of shingles designed for service without a factory-applied or field-applied sealant. These shingles, when applied in accordance with the manufacturers' application instructions, employ other means to provide resistance against the forces generated by the action of wind such as geometry and shingle construction. Field experience has shown that these types of shingles function satisfactorily in service. Because there are a variety of these shingle designs, it is not practical to describe in this test method how to test these shingles for uplift resistance. The testing of these types of shingles, therefore, goes beyond the scope of this test method.

1.3 This test method describes two procedures for measuring shingle uplift resistance. Procedure A employs a specially designed apparatus with a clamping device which facilitates lifting of the edge of the shingle and measuring the force required to break the seal. Procedure B employs a metal "T" section adhered to the weather surface of the shingle to facilitate application and measurement of a perpendicular force to break the seal.

1.4 It is not prohibited to use this test method over a range of sealing time and temperature combinations and testing temperatures to simulate a variety of actual field use conditions. The times and temperatures used shall be stated in the report.

1.5 The values stated in SI units are to be regarded as the standard. The inch-pound values given in parentheses are for information only.

1.6 *This standard does not purport to address all of the safety concerns, if any, associated with its use. It is the responsibility of the user of this standard to establish appro-*

*priate safety and health practices and determine the applicability of regulatory limitations prior to use.*

### 2. Referenced Documents

#### 2.1 ASTM Standards:

D 228 Test Methods for Asphalt Roll Roofing, Cap Sheets, and Shingles<sup>2</sup>

D 1079 Terminology Relating to Roofing, Waterproofing, and Bituminous Materials<sup>2</sup>

D 3462 Specification for Asphalt Shingles Made from Glass Felt and Surfaced with Mineral Granules<sup>2</sup>

### 3. Terminology

3.1 *Definitions*—For definition of terms used in this test method, refer to Terminology D 1079.

#### 3.2 *Definitions of Terms Specific to This Standard:*

3.2.1 *seal*—as it relates to steep roofing shingles, is the bonding that results from the activation of the sealant under the action of time and temperature.

3.2.2 *sealant*—as it relates to steep roofing shingles, is defined as factory-applied or field-applied material designed to seal the shingles to each other under the action of time and temperature after the shingles are applied to a roof.

3.2.3 *sealed*—as it relates to steep roofing shingles, is the condition of the shingles after the sealant has been activated by the action of time and temperature.

### 4. Summary of Test Method

4.1 The test specimens are constructed from pieces of shingles, overlaid and sealed prior to testing. All specimens are then conditioned and tested at selected temperatures. Specimens are tested in Procedure A by lifting the exposed edge and recording the uplift force required to break the seal, and in Procedure B, by recording the perpendicular force required to break the seal.

### 5. Significance and Use

5.1 Uplift resistance is one of the properties of an applied shingle that relates to its ability to withstand wind forces. The

<sup>1</sup> This test method is under the jurisdiction of ASTM Committee D08 on Roofing and Waterproofing and is the direct responsibility of Subcommittee D08.02 on Prepared Roofings, Shingles and Siding Materials.

Current edition approved July 10, 2003. Published August 2003. Originally approved in 1999. Last previous edition approved in 2003 as D 6381 – 03.

<sup>2</sup> *Annual Book of ASTM Standards*, Vol 04.04.

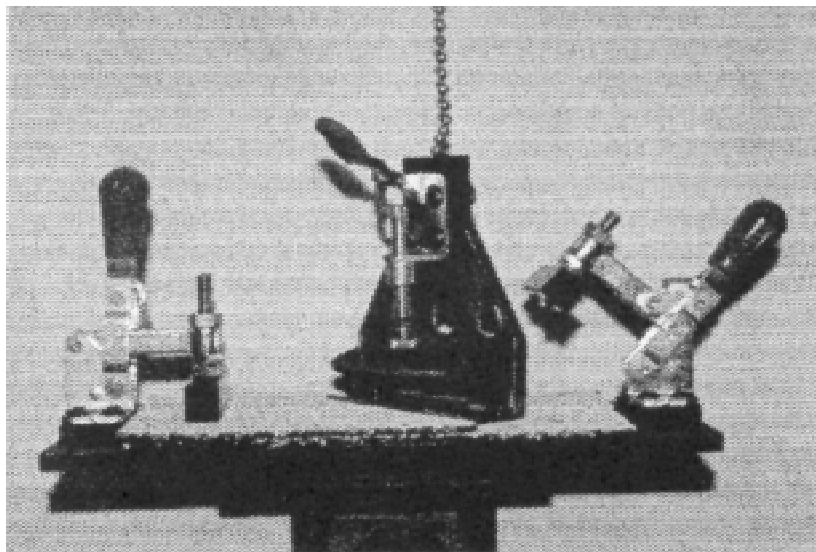

**FIG. 1 Shingle Uplift Test Apparatus—Procedure A**

mechanical tests described are laboratory methods to measure that resistance at a designated temperature after the shingles have been sealed under designated conditions.

5.1.1 No quantitative relationship has been established between the mechanical uplift resistance and uplift forces due to the wind.

5.2 Many factors influence the sealing characteristics of shingles in the field; for example, temperature, time, contamination by dirt and debris, roof slope, and interference by misplaced fasteners. It is not the objective of this test method to address all of these influences. This test method is designed to determine the mechanical uplift resistance when representative specimens of shingles are sealed under selected conditions prior to testing.

5.3 Procedure A produces lower results than Procedure B. Procedure A provides an edge-lift load value and Procedure B provides a perpendicular load value. The procedure applicable to a specific product depends on the specific product design, geometry, and rigidity. It is the responsibility of the user of this test method to determine the appropriate procedure with reference to the specific product and application. It is possible that engineering calculations would require both procedures to be employed, and for both results to be used in the calculation of the resistance of that specific product to the effects of wind.

## 6. Apparatus

6.1 The *Tensile Testing Machine*, shall be a constant-rate-of-extension (CRE) type.

6.2 *Heavy-Duty Paper Cutter*, steel rule, die, or template 95 by 114 mm (3¾ by 4½ in.) and 95 by 178 mm (3¾ by 7 in.) for Procedure A, and 102 by 152 mm (4 by 6 in.) and 95 by 38 mm (3¾ by 1½ in.) for Procedure B.

6.3 *The Test Fixture for Procedure A* is a specially designed apparatus and drawings are on file at ASTM International

Headquarters.<sup>3</sup> Fig. 1 is a photo of the apparatus in a typical tensile testing machine with a specimen in place.

6.4 *The Test Fixture for Procedure B* is identical to that used to determine Fastener Pull-Through Resistance in Specification D 3462, except that a 3 mm (⅛ in.) -thick aluminum mask 102 by 152 mm (4 by 6 in.) with a central opening 44 by 102 mm (1¾ by 4 in.) is used to restrain the specimen, and a 95 mm (3¾ in.) length of 38 mm (1½ in.) aluminum “T” section is used to apply the perpendicular uplift force to the specimen. Two 127 mm (5 in.) equal lengths of chain form a bridle that is hooked into holes drilled in the web of the “T” section. Fig. 2 is a photo of the apparatus in a typical tensile testing machine with a specimen in place.

6.4.1 The two chains are suspended from a common closed S-hook that is pinned, but free to rotate, in the upper fixture of the test machine. Open S-hooks attached to the end of each chain are inserted into holes drilled 6 mm (¼ in.) from each end, and 13 mm (½ in.) from the top, of the web of the “T” section. This arrangement of hooks and chains forms a free-swinging bridle that ensures perpendicular force application, and minimizes inducement of peeling forces, even when the test specimens are not uniformly sealed along their length.

6.5 *Temperature-Controlled Chamber*, to seal the specimens, capable of maintaining a temperature within  $\pm 1.5^{\circ}\text{C}$  ( $\pm 2.5^{\circ}\text{F}$ ) of the selected temperature. The sample tray shall be a rigid support large enough to hold specimens in the chamber.

<sup>3</sup> The sole source of supply of the apparatus known to the committee at this time is Ashcraft Machine and Supply Inc., 185 Wilson St., Newark, Ohio 43055. Specify Shingle Tab Uplift Tester, Model 102. If you are aware of alternative suppliers, please provide this information to ASTM International Headquarters. Your comments will receive careful consideration at a meeting of the responsible technical committee,<sup>1</sup> which you may attend.

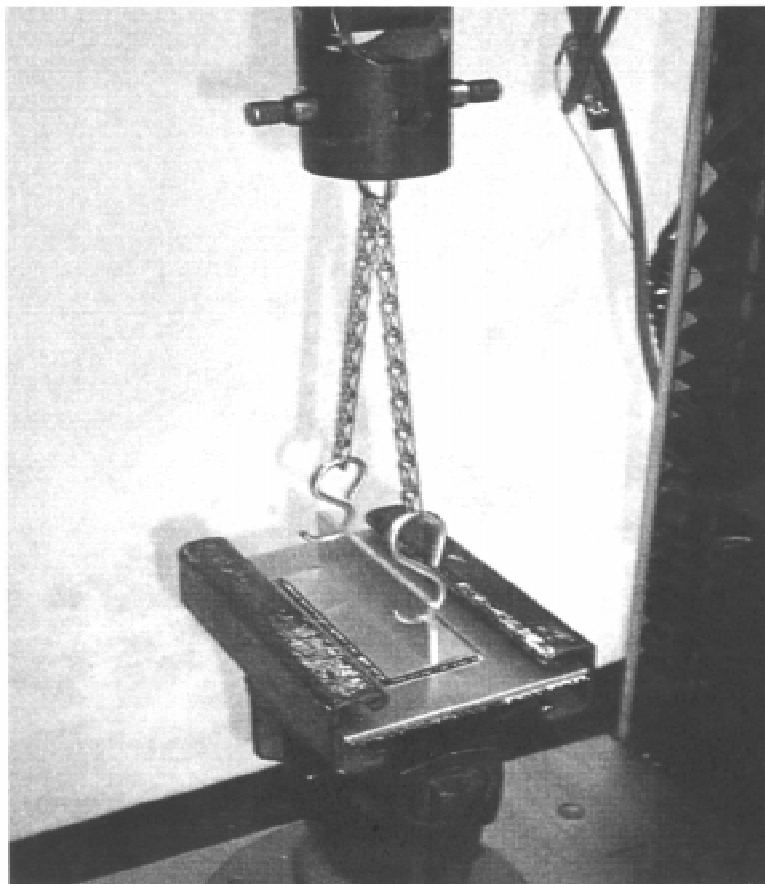

**FIG. 2 Shingle Uplift Test Apparatus—Procedure B**

6.6 *Temperature-Controlled Test Chamber*, capable of control within  $\pm 1.5^{\circ}\text{C}$  ( $\pm 2.5^{\circ}\text{F}$ ) which shall be used when testing the specimens at other than room temperature.

## 7. Specimen Preparation

7.1 Samples for testing shall be selected in accordance with the method specified in the sampling section of Test Methods D 228. The test shall consist of ten specimens per test condition, as described in the following paragraphs.

7.2 Specimens taken from the sample of shingles shall be representative of the typical geometry (area), thickness (caliper), and contamination level (back surface particles, and so forth) of the adhesive in the lot of material being investigated.

7.3 When using Procedure A, insertion of the test apparatus can be a problem for cases where the sealant is brittle and weak or where it is applied close to the leading edge of the shingle. For these, and other such cases where normal insertion of the top clamp of the apparatus is a concern, an alternate technique of attaching to the top of the specimen is not prohibited (see 7.7.3).

7.4 The sealant present on the specimen to be tested shall be proportionally representative of the sealant present on the shingle when it is installed in the field. For example, if the linear coverage of the sealant geometry on a shingle using

factory-applied sealant is 50 %, then the sealant shall cover 50 % of the width of the test specimen.

7.4.1 For a specimen representing field-applied sealant, for example, if the sealant is in a dot pattern then the same dot size and pattern shall be used on the laboratory-prepared specimen, following the manufacturer's application instructions.

7.5 In Procedure A, a specimen consists of a bottom piece 95 by 178 mm ( $3\frac{3}{4}$  by 7 in.); and a top piece 95 by 114 mm ( $3\frac{3}{4}$  by  $4\frac{1}{2}$  in.); both cut from one shingle as shown in Fig. 3a for single-layer shingles or Fig. 3b for multi-layer shingles. For multi-layer shingles that do not have a single-layer area from which to cut the top piece, cut the top piece at the point of the fewest layers. Longer or shorter specimens are not prohibited provided both clamps secure the specimen when it is aligned in the test fixture. The length of the specimens shall be determined for proper alignment in the fixture. Dimensional tolerances are  $\pm 3$  mm ( $\pm \frac{1}{8}$  in.) on the width of the specimen.

7.6 In Procedure B, a specimen consists of a bottom piece 102 by 152 mm (4 by 6 in.) and a top piece 38 by 95 mm ( $1\frac{1}{2}$  by  $3\frac{3}{4}$  in.) both cut from one shingle as shown in Fig. 3a for single-layer shingles, or Fig. 3b for multi-layer shingles. For multi-layer shingles that do not have a single-layer top piece,

**ASTM D 6381 – 03a**

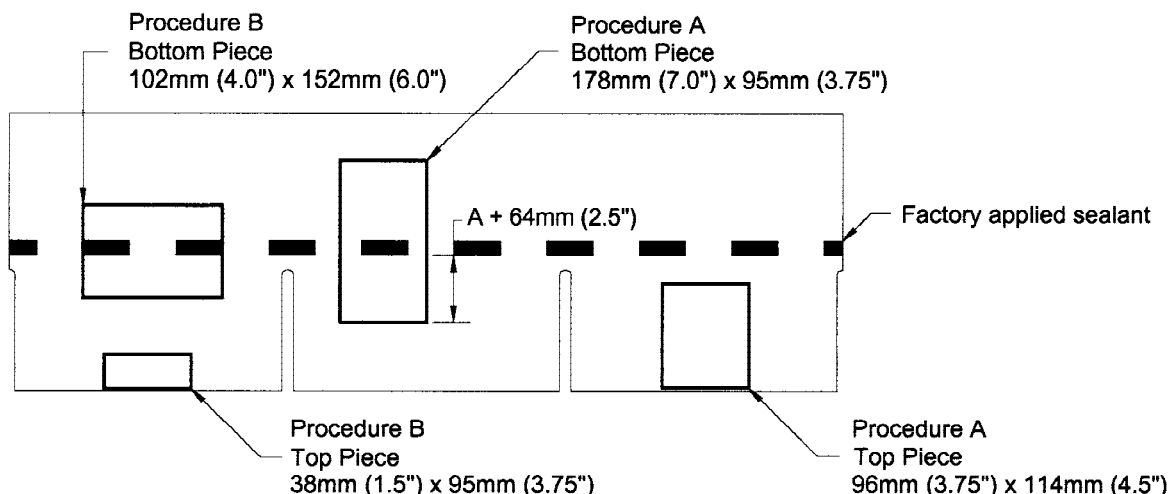

Dimensional Tolerances  $\pm 3\text{mm}$  (0.125")  
Not to scale

FIG. 3a Plan View of Shingle-Layer Shingle Showing Typical Specimen Locations

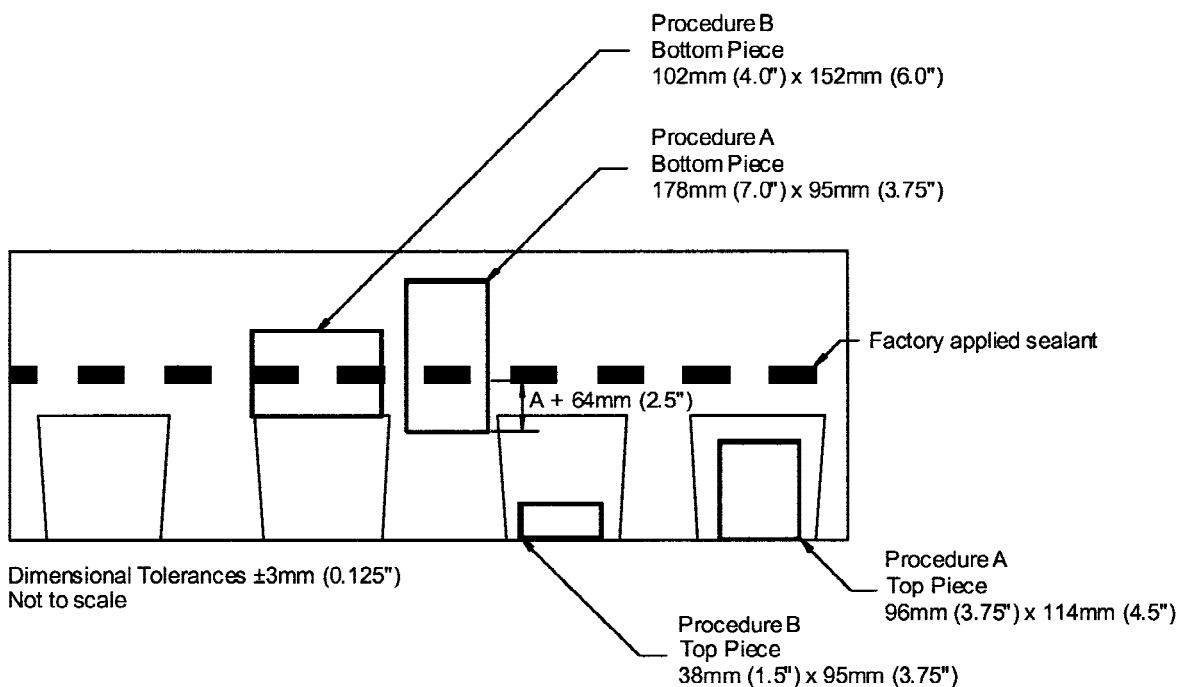

Dimensional Tolerances  $\pm 3\text{mm}$  (0.125")  
Not to scale

FIG. 3b Plan View of Multi-Layer Shingle Showing Typical Specimen Locations

cut the top piece at the point of the fewest layers. Dimensional tolerances are  $\pm 3\text{ mm}$  ( $\pm 1/8\text{ in.}$ ) on the width and length of the specimen.

7.7 In Procedure A, lay the top piece over the bottom piece, as shown in Figs. 4a and 4b, and in a manner representative of the actual alignment as specified in the shingle manufacturer's application instructions.

7.7.1 Not all multi-layer shingles have the sealant in the same location on the shingle. Whether the sealant is on the top of the bottom piece, or on the bottom of the top piece, the "A"

dimension in Procedure A is determined by measuring the distance from the leading edge of the sealant to the leading edge of the top piece when the sample pieces are correctly positioned (in accordance with 7.7). In the case where the sealant is on the back of the top piece, the bottom piece shall be cut so that when the top piece is correctly positioned on the bottom piece, the sealant is in contact with the lower shingle in the same area of the surface it would contact when correctly installed on a roof in accordance with the manufacturer's instructions. The critical dimension in Procedure A is the

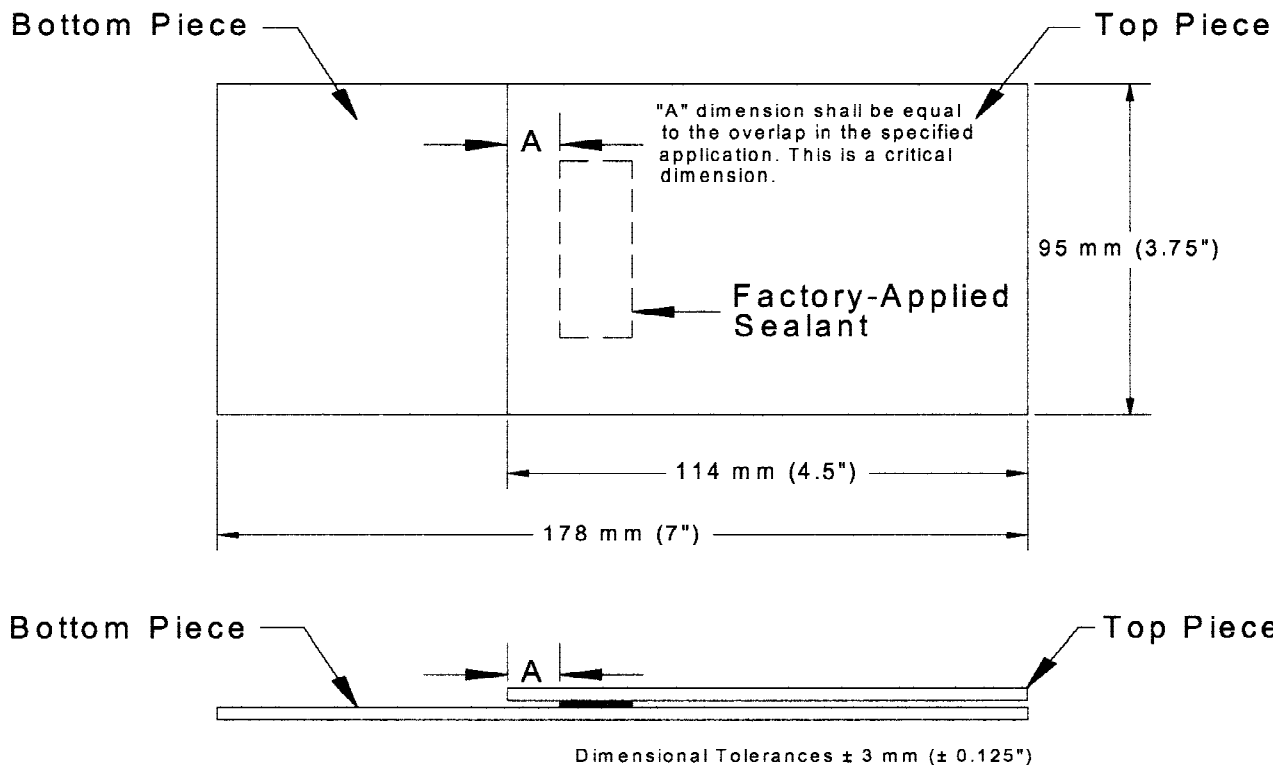

**FIG. 4a Top and Side View of Test Specimen—Procedure A**

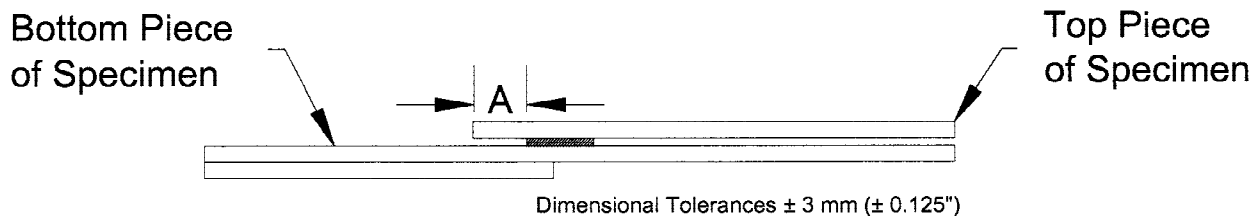

**FIG. 4b Side View of Multi-Layer Test Specimen—Procedure A**

distance the top piece overlaps the sealant on the bottom piece (denoted A in Figs. 4a and 4b). This dimension shall be equal to the overlap in the specified application.

7.7.2 Position the specimens on the tray without overlapping or stacking of the individual specimens.

7.7.3 For cases when an alternate top attachment method is desired (see 7.3) a special metal connector<sup>4</sup> shall be epoxy-bonded to the top piece of the specimen following sealant bonding and prior to conditioning and testing. This metal connector shall be equal to the width of the specimen. It shall be positioned at the edge of the top piece and bonded to

adequately attach to the top of the specimen to facilitate insertion of the test fixture. A photo of the connector, attached to a test specimen, is shown in Fig. 5. The top clamp assembly attached to this connector is shown in Fig. 6.

7.8 In Procedure B, lay the top piece centered over the bottom piece as shown in Fig. 7a. The pieces are cut such that the sealant material is centered on the long axis of the rectangular piece, and is either on the weather surface of the bottom piece or the bottom surface of the top piece depending on the shingle design.

7.8.1 It is not possible to anticipate all potential shingle variations such as shape, number of layers, position, geometry, and nature of sealant, and so forth. Provided that the principle of Procedure B, the geometry of the specimen pieces, and the central location of the sealant in the specimen in the test fixture is satisfied, it is not prohibited to use two pieces of shingle

<sup>4</sup> The sole source of supply of the apparatus known to the committee at this time is Ashcraft Machine and Supply, 185 Wilson St., Newark, Ohio 43055, and specified on the drawings for the apparatus. If you are aware of alternative suppliers, please provide this information to ASTM International Headquarters. Your comments will receive careful consideration at a meeting of the responsible technical committee<sup>1</sup>, which you may attend.

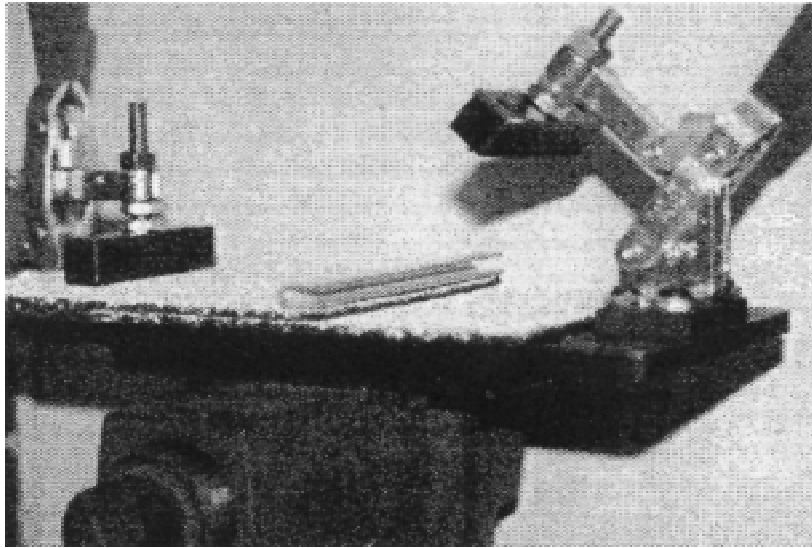

**FIG. 5 Connector for Special Top Attachment—Procedure A**

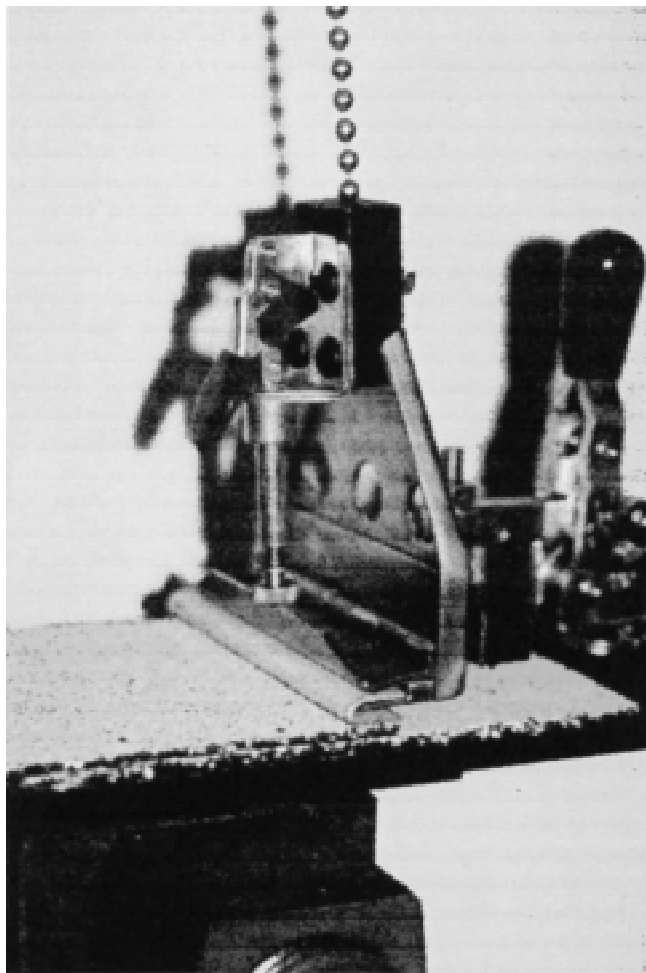

**FIG. 6 Top Clamp Assembly Attached to Connector—Procedure A**

butted together to satisfy the requirements. When this is done, it shall be stated in the report (see 11.1.5).

## **8. Calibration and Standardization**

8.1 *CRE Tensile Tester:*

8.1.1 Set up the testing machine with the test fixture in place with the following operating parameters:

8.1.1.1 *Crosshead Speed*—2 mm/s (5 in./min), and

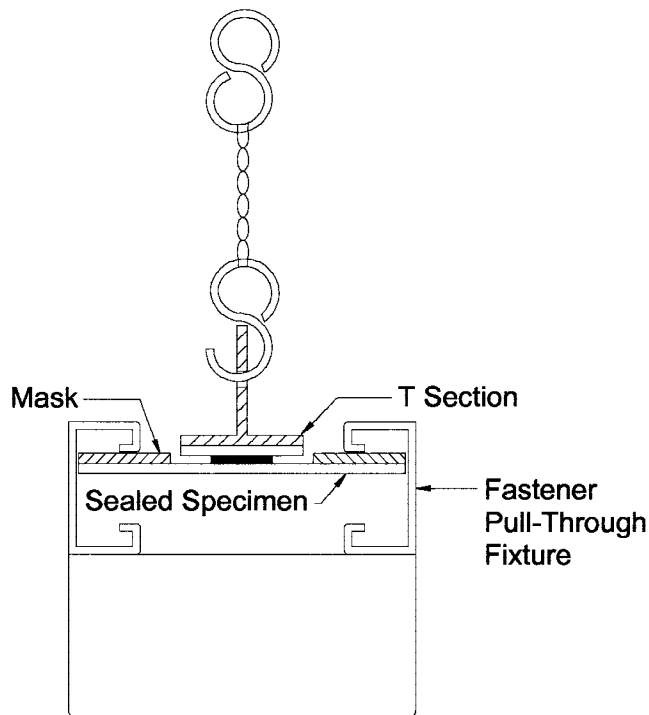

FIG. 7a Side View of Test Fixture and Specimen—Procedure B

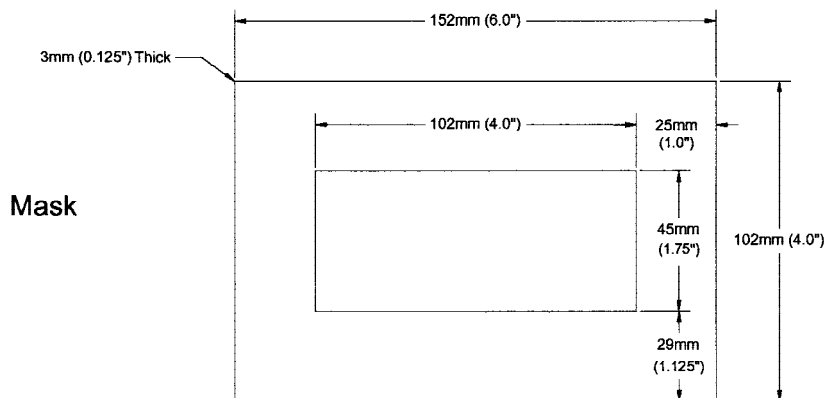
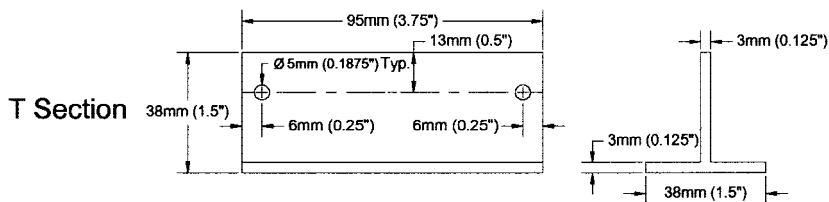

FIG. 7b Detail of "T"-Section and Mask—Procedure B

8.1.1.2 *Gage Length*—Set to accommodate the test fixture without putting any strain on the sealant joint.

8.1.2 In Procedure A, zero the tester with the top clamp assembly in place hanging freely.

8.1.3 In Procedure B, zero the tester with the chain bridle, the hooks, and the "T" section with a typical top piece of specimen glued in place, hanging freely to "tare" the apparatus (without bottom piece and mask).



## 9. Sealing and Conditioning

9.1 Seal the specimens on a sample tray, oriented horizontally, at the designated temperature,  $\pm 1.5^{\circ}\text{C}$  ( $\pm 2.5^{\circ}\text{F}$ ) for the desired time,  $\pm 2\%$ .

9.2 Without disturbing the specimen arrangement, after sealing, condition the specimens at the desired test temperature,  $\pm 1.5^{\circ}\text{C}$  ( $\pm 2.5^{\circ}\text{F}$ ), for at least 1 h.

9.2.1 In Procedure B, the “T”-section is adhered after sealing the specimens and before conditioning.

## 10. Procedure

### 10.1 Procedure A:

10.1.1 Open both clamps and carefully slide the conditioned specimen into the test fixture. Align the specimens so that the sealant centerline corresponds to the vertical centerline of the test apparatus and centered in the fixture in both directions. Exercise care in positioning specimens in the test fixture to avoid disturbing the temperature of the specimens or the nature of the seal.

10.1.2 Position the top clamp assembly under the top overlap, using the thumb to operate the clamp. Close the clamps to secure the specimen. Operate the tensile tester and record maximum force to the nearest 1.0 N (0.2 lbf).

10.1.3 Repeat 10.1.1 and 10.1.2 for the remaining specimens.

10.1.4 When the sealant bond breaks in the course of attaching the top clamp to the overlap piece, this specimen is counted and entered as a zero value. A specimen that is mishandled, such as being dropped or inadvertently twisted in handling, shall be replaced with another sealed and conditioned specimen.

### 10.2 Procedure B:

10.2.1 Attach the flat surface of the inverted aluminum “T” section to the top surface of the top piece using a suitable adhesive applied to the entire area of the flat surface of the “T” (epoxy and urethane adhesives have been found suitable). The flat surface of the “T” shall be coincident with the top surface of the top piece (the two surfaces are the same size). Take care not to disturb the sealed specimen by floating the “T” section on the fluid adhesive, and also to assure that the web of the “T” section is as close as possible to being perpendicular to the plane of the shingle.

10.2.2 After the adhesive has cured, and the specimen has been conditioned, carefully place the conditioned specimen with the aluminum “T” section attached, into the test fixture so that the “T” section is centered in the rectangular hole in the mask, as shown in Fig. 2 and Fig. 7a. Details of the “T” section and Mask of the test fixture are shown in Fig. 7b.

10.2.3 Attach both hooks of the chain bridle into the holes in the web of the “T” section, operate the tensile tester, and record the maximum force to the nearest 1.0 N (0.2 lbf). (See calibration and zeroing in 8.1.3).

10.2.4 When the “T” section detaches from the specimen, in whole or in part, during the load application as a result of failure of the adhesive (the glue, not the shingle sealant) then the specimen shall be replaced with a new sealed and conditioned specimen. When the sealant breaks during normal handling of the specimen, or installing the specimen into the

test fixture, this specimen is counted and entered as a zero value. A specimen that is mishandled, such as being dropped or inadvertently twisted in handling, shall be replaced with another sealed and conditioned specimen.

## 11. Report

11.1 Report the following information:

11.1.1 Basic identifying information about the shingle, if available, including manufacturer, shingle type, production date code, lot number, sealant type, sealant location (front/back), “A” dimension (when using Procedure A), number of layers in multi-layer shingle, and sealant pattern.

11.1.2 The type of test machine and the rate of jaw movement employed,

11.1.3 The time and temperature used to seal the specimens and the test temperature,

11.1.4 The specific procedure used, A or B,

11.1.5 The exact geometry of the specimen pieces if more than one piece is required to satisfy the specimen geometry in Procedure B,

11.1.6 The average of the force needed to break the seal of ten specimens, to the nearest 1.0 N (0.2 lbf).

11.1.7 The type of back-surfacing on the shingle and any other distinguishing features; for example, extent of coverage, evidence of contamination of the sealant, and so forth, and

11.1.8 Any other observations about the sealant bond performance.

## 12. Precision and Bias

12.1 Precision:

12.1.1 Procedure A:

12.1.1.1 The following criteria shall be used to judge the acceptability of results at the 95 % confidence level.

12.1.1.2 *Repeatability*—Duplicate results by the same operator shall be considered suspect if the difference between them is greater by more than 20 % of the smaller result.

12.1.1.3 *Reproducibility*—The results submitted by each of two laboratories shall be considered suspect if the difference between them is greater by more than 35 % of the smaller result.

NOTE 1—Repeatability and reproducibility estimates were developed for Procedure A using laboratory-applied rather than factory-applied sealant, which is a departure from this test method as written. Uniformity of laboratory-applied sealant typically results in substantial reduction of repeatability and reproducibility when compared with factory-applied sealant.

12.1.2 Procedure B:

12.1.2.1 The following criteria shall be used to judge the acceptability of results at the 95 % confidence level.

12.1.2.2 *Repeatability*—Duplicate results by the same operator shall be considered suspect if the difference between them is greater by more than 11 % of the smaller result.

12.1.2.3 *Reproducibility*—The results submitted by each of two laboratories shall be considered suspect if the difference between them is greater by more than 21 % of the smaller result.

12.2 *Bias*—This test method has no bias because shingle mechanical uplift resistance is defined only in terms of this test method.





### 13. Keywords

resistance

13.1 asphalt shingle; factory-applied sealant; field-applied sealant; sealant bond strength; shingle mechanical uplift

*ASTM International takes no position respecting the validity of any patent rights asserted in connection with any item mentioned in this standard. Users of this standard are expressly advised that determination of the validity of any such patent rights, and the risk of infringement of such rights, are entirely their own responsibility.*

*This standard is subject to revision at any time by the responsible technical committee and must be reviewed every five years and if not revised, either reapproved or withdrawn. Your comments are invited either for revision of this standard or for additional standards and should be addressed to ASTM International Headquarters. Your comments will receive careful consideration at a meeting of the responsible technical committee, which you may attend. If you feel that your comments have not received a fair hearing you should make your views known to the ASTM Committee on Standards, at the address shown below.*

*This standard is copyrighted by ASTM International, 100 Barr Harbor Drive, PO Box C700, West Conshohocken, PA 19428-2959, United States. Individual reprints (single or multiple copies) of this standard may be obtained by contacting ASTM at the above address or at 610-832-9585 (phone), 610-832-9555 (fax), or service@astm.org (e-mail); or through the ASTM website (www.astm.org).*