



Standard Test Method for Splitting Tensile Strength of Masonry Units¹

This standard is issued under the fixed designation C 1006; the number immediately following the designation indicates the year of original adoption or, in the case of revision, the year of last revision. A number in parentheses indicates the year of last reapproval. A superscript epsilon (ϵ) indicates an editorial change since the last revision or reapproval.

1. Scope

1.1 This test method covers the determination of the splitting tensile strength of masonry units.

1.2 *This standard does not purport to address all of the safety concerns, if any, associated with its use. It is the responsibility of the user of this standard to establish appropriate safety and health practices and determine the applicability of regulatory limitations prior to use.*

2. Referenced Documents

2.1 *ASTM Standards:*

E 4 Practices for Force Verification of Testing Machines²

3. Significance and Use

3.1 Masonry units alone and within assemblages commonly fail in a tensile mode when loaded in compression to failure. These tensile stresses result from differences in modulus of elasticity and Poisson's ratio between the masonry unit and mortar. Additionally, the dissimilarity in behavior of the grout within cores of masonry units under load leads to tensile stresses in the units and results in a splitting failure.

3.2 This test method produces a line load along the bed surface of the masonry unit. The compressive load applied to the unit, imposed by means of bearing rods, results in a tensile stress distributed over the height of the unit for the split length of the unit. This test method can be applied in either the longitudinal (parallel to the face) or the transverse direction. The splitting tensile strength is calculated by the equation given in 7.1.

3.3 The test value provides an indicator of masonry-unit splitting tensile strength. Additionally, the presence of defects such as visible voids or impurities in masonry units may be revealed.

4. Apparatus

4.1 *Bearing Rods*—Matched, paired steel bearing rods with diameters within $\frac{1}{8}$ to $\frac{1}{2}$ of the specimen height, of a length

greater than the length of the intended test area, and of straightness within 0.5 % of the specimen length shall be provided for each unit. Bearing rods that meet the straightness requirement can be reused.

4.2 *Supplemental Bearing Bar or Plate*—If the diameter or largest dimension of the upper bearing face or lower bearing block is less than the length of the specimen to be tested, a supplementary bearing bar or plate shall be used. The contact surfaces of the bar or plate shall be machined to within 0.05 % of planeness as measured on any line of contact of the bearing area. The bearing bar or plate shall have a width of at least 2 in. (50.8 mm), and a thickness not less than the distance from the edge of the spherical or rectangular bearing block to the end of the specimen. The bar or plate shall be used in such a manner that the load will be uniformly applied over the entire intended split length of the specimen.

4.3 *Testing Machine:*

4.3.1 The testing machine shall conform to the requirements of Practices E 4, and may be of any type of sufficient capacity that will provide the rate of loading prescribed in 6.3.

4.3.2 The upper, hardened metal bearing face shall be spherically seated and attached at the center of the upper head of the machine. The center of the sphere shall lie at the center of the surface of the plate in contact with the specimen. The bearing plate shall be closely held in its spherical seat but shall be free to turn in any direction; its perimeter at the ball face shall have at least $\frac{1}{4}$ in. (6.4 mm) clearance from the head of the machine to allow for specimens whose test surfaces are not exactly parallel. The diameter of the bearing surface shall be at least 5 in. (127 mm). The bearing block surfaces that will contact the bearing bar or plate shall not depart from plane surfaces by more than 0.05 %.

5. Sampling

5.1 *Selection*—For the purpose of this test, full-size masonry units shall be selected at random by the purchaser or by his authorized representative. The specimens shall be representative of the whole lot of units from which they are selected and shall include units representative of the complete range of colors and sizes in the shipment.

¹ This test method is under the jurisdiction of ASTM Committee C15 on Manufactured Masonry Units and is the direct responsibility of Subcommittee C15.04 on Research.

Current edition approved Jan. 5, 1984. Published February 1984.

² *Annual Book of ASTM Standards*, Vol 03.01.

5.2 *Number*—A minimum of five specimens shall be tested for the first 250 000 units. The minimum number of test specimens shall be increased by one unit for each 50 000 additional units or fraction thereof.

6. Procedure

6.1 *Positioning Bearing Rods:*

6.1.1 For units less than 4 in. (101.6 mm) high, mark the intended location of the split surface on both faces, stretcher or normally exposed faces for transverse splitting, and end faces for longitudinal splitting. Spread a gypsum capping compound (Note 1) along the bed surface between these two marks. Place the bearing rod into the fresh compound and press until contact is made with the unit. After the compound has set, place the second bearing rod parallel to the first on the opposite bed surface using an alignment device as illustrated in Fig. 1. The two rods must be within ¼ in. (6.4 mm) in 8 in. (203.2 mm) of being parallel.

NOTE 1—The gypsum capping compound shall be an alphasulfate hemihydrate.³

6.1.2 For units ≥4 in. (101.6 mm) high, use a carpenter’s square to draw a line perpendicular to the bed surface on opposite exterior faces. Spread capping compound on the upper bed surfaces between the two lines. Align the bearing rods with the lines on the faces, and press one rod into the fresh compound until in contact with the unit. After the compound has set, invert the unit and repeat this procedure on the opposite bed surface. The two companion rods must be within ¼ in. (6.4 mm) in 8 in. (203.2 mm) of being parallel.

6.1.3 The bearing rods shall be positioned no closer to a free edge than one half the specimen height.

6.1.4 Cure the capping compound for at least 2 h at 75 ± 5°F (22 ± 18°C) prior to testing.

NOTE 2—Alternative methods of applying the line load to the specimen have been used. Wood strips, metal bars of square cross section, and half rounds have been utilized. Such devices, meeting the dimensional requirements of 4.1, are permitted on specimens greater than 4 in. (101.6

mm) in height. The user of any modification should provide comparative data, testing both ways, to validate the alternative method.

6.2 *Test Alignment*—Align the rods with the centerline of the plates, and center the rods in the transverse direction. Support the specimen on compressible rods or tubes that are 1/16 in. (1.8 mm) smaller in diameter than the bearing rods. Remove the compressible rods when the specimen is held in vertical orientation by the testing-machine platens.

6.3 *Rate of Loading*—Apply the load without impact and load continuously at a rate less than 2000 lbf/min (8896 N/min).

NOTE 3—This requirement is met if the speed of the moving head of the testing machine immediately prior to application of load is not more than 0.5 in./min (12.7 mm/min).

6.4 *Measurement*—Determine the height of the specimen to the nearest 0.1 in. (2.5 mm) by averaging three heights measured near the ends and the middle and on a plane perpendicular to the bed surface. Determine the split length of the specimen to the nearest 0.1 in. (2.5 mm) by averaging at least two measurements taken on the plane of the bearing rods. Measure net length for hollow units and gross length for solid units.

7. Calculations

7.1 Calculate the splitting tensile strength of the specimens as follows:

$$T = 2P/\pi LH \tag{1}$$

where:

- T* = splitting tensile strength, psi (kPa),
- P* = maximum applied load indicated by the testing machine, lb (kN),
- L* = split length, in. (m), net length for hollow units, gross length for solid units, and
- H* = height, in. (m).

8. Report

8.1 The report shall include the following for each masonry unit.

- 8.1.1 Type and dimensions of specimen,
- 8.1.2 Identification number,
- 8.1.3 Split length and height of split area of specimen in inches (metres),
- 8.1.4 Maximum load in pound force (kilonewtons),
- 8.1.5 Splitting tensile strength calculated to the nearest 5 psi (34.5 kPa),
- 8.1.6 Visible voids and impurities in specimen, and
- 8.1.7 Description of fracture.

8.2 Report and average splitting tensile strength of the units tested.

9. Precision and Bias

9.1 The coefficient of variation of test results available is high because of the variability of the material property tested. Coefficients of variation for groups of five specimens ranged from 3 to 40 %, averaging 20 %.

9.1.1 It is expected that the multilaboratory coefficients of variation will be higher than the single operator or single laboratory coefficient of variation.

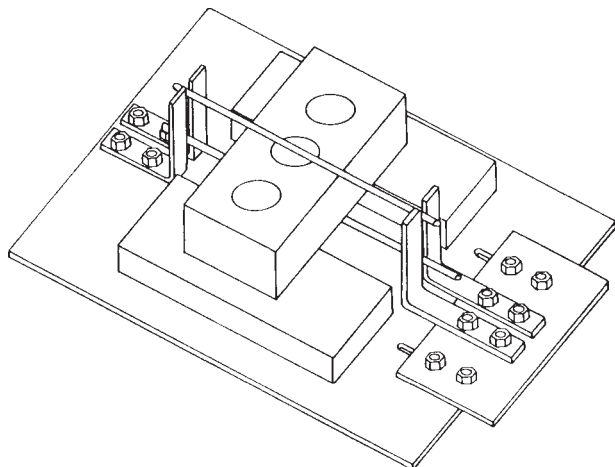

FIG. 1 Example of Alignment Jig for Maintaining Parallel Bearing Rods

³ U.S. Gypsum Hydrostone or Georgia Pacific Densite K5.

9.1.2 Longitudinal-splitting test results normally have higher coefficients of variation than those split in transverse direction.

10. Keywords

10.1 brick; concrete masonry units; masonry; splitting strength; tensile strength

ASTM International takes no position respecting the validity of any patent rights asserted in connection with any item mentioned in this standard. Users of this standard are expressly advised that determination of the validity of any such patent rights, and the risk of infringement of such rights, are entirely their own responsibility.

This standard is subject to revision at any time by the responsible technical committee and must be reviewed every five years and if not revised, either reapproved or withdrawn. Your comments are invited either for revision of this standard or for additional standards and should be addressed to ASTM International Headquarters. Your comments will receive careful consideration at a meeting of the responsible technical committee, which you may attend. If you feel that your comments have not received a fair hearing you should make your views known to the ASTM Committee on Standards, at the address shown below.

This standard is copyrighted by ASTM International, 100 Barr Harbor Drive, PO Box C700, West Conshohocken, PA 19428-2959, United States. Individual reprints (single or multiple copies) of this standard may be obtained by contacting ASTM at the above address or at 610-832-9585 (phone), 610-832-9555 (fax), or service@astm.org (e-mail); or through the ASTM website (www.astm.org).