



Designation: C 1147 – 9501

Standard Practice for Determining the Short Term Tensile Weld Strength of Chemical-Resistant Thermoplastics¹

This standard is issued under the fixed designation C 1147; the number immediately following the designation indicates the year of original adoption or, in the case of revision, the year of last revision. A number in parentheses indicates the year of last reapproval. A superscript epsilon (ϵ) indicates an editorial change since the last revision or reapproval.

1. Scope

1.1 This practice covers the preparation and evaluation of joints between two pieces of weldable grades of thermoplastic materials, backed and unbacked, (such as those shown in Table 1) up to 2 in. (50 mm) in thickness.

1.2 Since there are numerous new technologies and techniques constantly being developed for plastic welding, there are no profiles and procedures that can be considered as standard for all plastics at various thicknesses. This practice is not intended to define profiles and procedures; however, it is intended to establish methods to evaluate minimum short term weld factors to be achieved by the welder for the respective plastics.

1.3 Weld procedures used for test pieces should reflect procedures to be used in actual fabrication.

1.4 Welding methods to be used could include machine welding, extrusion welding, and hot gas welding.

1.5 The values stated in inch-pound units are to be regarded as the standard. The values given in parentheses are for information only.

2. Referenced Documents

2.1 *ASTM Standards:*

C 904 Terminology Relating to Chemical-Resistant Nonmetallic Materials²

¹ This practice is under the jurisdiction of ASTM Committee ~~C-3~~ C03 on Chemical-Resistant Nonmetallic Materials and is the direct responsibility of Subcommittee C03.03 on Thermoplastic Fabrications.

Current edition approved ~~Sept. 10, 1995~~; 2001. Published ~~November 1995~~; July 2001. Originally published as C 1147 – 90. Last previous edition C 1147 – 90~~5~~.

TABLE 1 Typical Guide for Hot Gas Welding Temperatures

NOTE 1—For other welding techniques, consult material and equipment supplier for recommendations.

	°F ^A	Recommended Gas Type ^B
HDPE	500–600	Nitrogen or Air
PP	550–600	Nitrogen or Air
PVC	500–550	Air
CPVC	550–660	Air
PVDF	650–680	Nitrogen or Air
ECTFE	665–695	Nitrogen
ETFE	675–710	Air
FEP	650–725	Air
PFA	675–750	Air
MFA	536–554	Air

^A Measured 1/4 in. inside weld tip, directly in gas stream.

^B Inert gas may be used in place of air.

D 4285 Test Method for Indicating Oil or Water in Compressed Air³

E 4 Practices for Force Verification of Testing Machines⁴

3. Terminology

3.1 *Definitions*—For definitions of terms used in this practice, see Terminology C 904.

4. Summary of Practice

4.1 The sheets are prepared and welded. Tensile test specimens containing a section of the weld are prepared and tested. Specimens of unwelded sheet are tested and compared to the welded specimens. The short term weld factor determined is compared to the standard (see Table 2), or to the factor agreed upon between the supplier and the user.

5. Significance and Use

5.1 The mechanical performance of welded thermoplastic structures is largely dependent on the quality of the welding operation. Fabricators should determine that the proper welding procedures are being followed and that welders maintain their proficiency. Results from this practice are indicative of skill in proper welding procedures for different thermoplastic materials and the use of appropriate welding equipment. If the welded test specimens have short term weld factors that meet or exceed the minimums as set forth in this practice, or as agreed to by supplier and user, it may be concluded that, with the same degree of skill and diligence by the welder, acceptable welds should be obtained in fabricated structures.

6. Apparatus

6.1 The apparatus for welding shall consist of the following:

6.1.1 *Welding Device*, suitable for joining thermoplastics.

6.1.2 *Air Supply*, when needed, conforming to Test Method D 4285.

6.1.3 *Temperature Measuring Device*, capable of measuring the welding temperature to within $\pm 1\%$ for the specific plastic as set forth in Table 1.

6.1.4 *Clamps*, suitable for holding the specimen while welding.

6.1.5 *Saw*, suitable for cutting thermoplastic sheet.

² Annual Book of ASTM Standards, Vol 04.05.

³ Annual Book of ASTM Standards, Vol 06.02.

⁴ Annual Book of ASTM Standards, Vol 03.01.

TABLE 2 Minimum Short Term Weld Factors

Thermoplastic	Hot Gas	Extrusion	Hot Plate
HDPE	0.8	0.8	0.9
PP	0.8	0.8	0.9
PVC	0.8	^A	0.9
CPVC	0.6	^A	0.8
PVDF	0.8	0.8	0.9
ECTFE	0.9	0.9	0.9
ETFE	0.9	0.9	0.9
FEP	0.9	0.9	0.9
TFE (PFA Filler)	0.9	0.9	^A
PFA	0.9	0.9	0.9

^A Not applicable.

6.1.6 *Sander, Router, Joiner, or Saw*, suitable for beveling edges of sheet.

6.2 The apparatus for testing tension specimens shall consist of the following:

6.2.1 *Tensile Machine*—A testing machine capable of pulling the specimens at a rate of 2 ± 0.1 in./min (50 ± 2.5 mm/min) of crosshead movement (speed of movement when the machine is running without a load).

6.2.1.1 The rate of movement between heads of the testing machine shall remain essentially constant under changing loads (see Note 1).

NOTE 1—It is difficult to meet this requirement when loads are measured with a spring type or pendulum type weighing device.

6.2.1.2 The testing machine shall measure the load to within 1 %. The testing range shall be so selected that the maximum load on the specimen falls between 15 and 85 % of the full scale capacity.

6.2.1.3 The use of autographic equipment to record the load versus head movement is recommended.

6.2.1.4 Verification of the testing machine shall be made in accordance with the recommendations of Practices E 4.

6.2.2 *Micrometer or Vernier Caliper*, suitable for measuring width and thickness of the test specimen to the nearest 0.001 in. (0.025 mm).

7. Test Specimens

7.1 *Test Pieces For Hot Gas and Extrusion Welding*—Start with a 10 by 42 in. (250 by 1050 mm) piece of plastic sheet of the type and thickness to be tested. Cut the sheet as shown in Fig. 1 to yield five pieces, four measuring 5 by 18 in. (125 by 450 mm) and one measuring 6 by 10 in. (150 by 250 mm). Two 5 by 18 in. pieces will be used for horizontal welding and two 5 by 18 in. pieces for vertical welding.

7.1.1 The 6 by 10 in. sample will be cut into control specimens as described in Section 7.2.2. Label each piece as to type of plastic, method of welding, orientation of welding and welder identification.

7.1.2 *Edge Preparation*—Bevel one 18 in. (450 mm) edge of each 5 by 18 in. piece in preparation for welding. Beveling shall be done using suitable apparatus such as routers, sanders, joiners, or saws, that accurately reflect methods utilized in the field. Typical bevel profiles for the various sheet thicknesses are illustrated in Fig. 2 and Fig. 3. These profiles are optional and do not have to be used by the fabricator to meet the weld test standard, however, experience has shown that the use of beveled edges is advantageous to weld quality in sheet greater than 60 mils (1.5 mm) in thickness in hot gas and extrusion welding processes. Do not use solvents or other chemicals for cleaning the beveled surfaces that in any way will adversely affect the properties of the plastic. The cleaning operation should not in any way alter the profile or bevel of the edge. Details of bevels and test procedures used should accompany test specimens and the report of test results.

7.1.3 *Welding Procedure*—Securely clamp the test sheets to be welded to a suitable fixture and adjust welding device temperature as specified in Table 1. Weld two specimens, one vertically to simulate tank walls, and one horizontally to simulate tank floors. If a machine such as a hot plate welder or other equipment that is in a fixed position is being used, the two test specimens, cut and configured as in 7.1, are welded in the machine's normal welding plane. The two samples shall not be welded in the same cycle of the machine. Welding procedures must be identified and adequately described as part of the report. The completed weld may be projecting above or be flush with adjacent surfaces.

7.2 Preparation of Test Specimens:

7.2.1 *Weld Test Specimens*—Cut and discard a 1 in. strip off each end of an 18 by 10 in. welded specimen resulting in a piece 16 by 10 in. (400 by 250 mm). Cut remaining piece across the weld into 1 ± 0.01 in. (25 ± 0.25 mm wide) by 10 in. (250 mm) long strips. The width of the test specimens can be varied depending on the capacity of the tensile machine and the type and thickness of plastic being tested. Set aside at least 10 of these specimens from the vertically welded sample and the same number from the horizontal for weld test evaluation and condition a minimum of 16 h at $73 \pm 4^\circ\text{F}$ ($23 \pm 2^\circ\text{C}$).

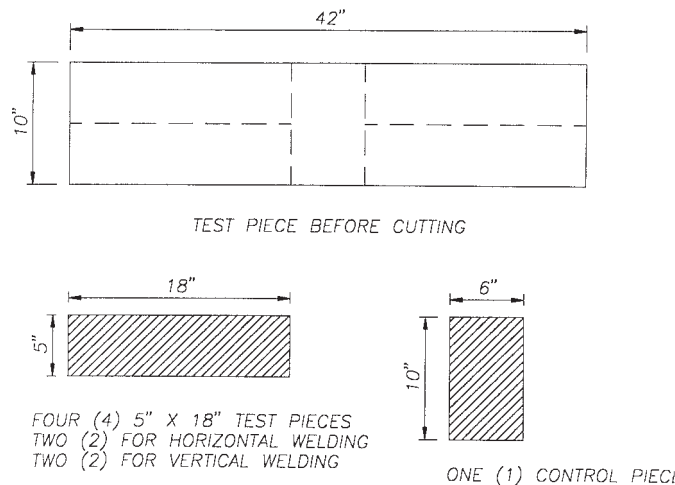
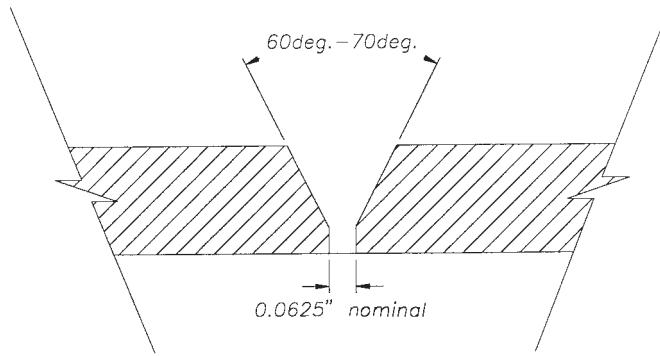
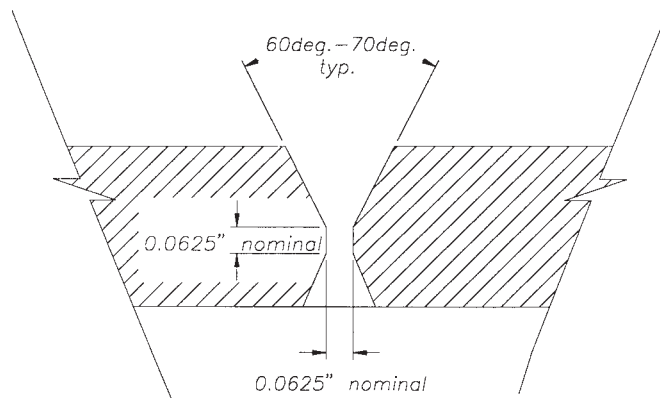

FIG. 1 Test Pieces



NOTE: Sheet width between 0.09" (2.3mm) to 0.5" (13mm) in thickness.

FIG. 2 Typical Bevel Profile (Sheet >0.090 to 0.5 in. (2.3 mm to 13 mm) in Thickness)



NOTE: Sheet width greater than 0.5" (13mm) in thickness.

FIG. 3 Typical Bevel Profile (Sheet >0.5 in. (13 mm) Thick)

7.2.2 *Control Specimens*—Cut 5 pieces off the 6 by 10 in. control specimen to the same dimensions as welded test specimens. Condition at least 5 specimens for evaluation for 16 h at $73 \pm 4^\circ\text{F}$ ($23 \pm 2^\circ\text{C}$).

8. Test Procedure

8.1 Tensile Strengths:

8.1.1 *Control Specimens*—Measure width and thickness of the test pieces to the nearest 0.001 in. (0.025 mm) at the one-third intervals of that length not held by the grips. Record the respective measurements, calculate the respective cross-sectional areas, and calculate the average cross-sectional area of test pieces.

8.1.1.1 Conduct the tensile test using a suitable test machine pulling at a cross-head speed of 2 ± 0.1 in. (50 ± 2.54 mm)/min.

8.1.2 *Welded Specimens*—Measure width and thickness of the test pieces to the nearest 0.001 in. (0.025 mm) at the one-third intervals of that length not held by the grips. Do not measure thickness within $\frac{1}{4}$ in. (6 mm) of the weld bead area. Record the respective measurements, calculate the respective cross-sectional areas and calculate the average cross-sectional area of test pieces.

8.1.2.1 Conduct the tensile test using a suitable test machine pulling at a cross-head speed of 2 ± 0.1 in. (50 ± 25.4 mm)/min.

9. Calculation

9.1 Calculate the tensile strengths of each specimen as follows:

$$S = P/A \quad (1)$$

where:

S = tensile strength, psi (MPa),

P = peak load lbf (or N), and

A = average cross-sectional area, in.² (or mm²).

9.1.1 Average cross-sectional area is the product of the average width and average thickness for each individual specimen as measured in 8.1.1 and 8.1.2.

9.1.2 When fabric backed sheet is tested, the overall thickness, including the fabric, shall be used in determining the thickness measurements in 8.1.1 and 8.1.2.

9.2 *Control Strength*—Calculate the *average* sheet strength of the 5 control specimens.

9.3 *Short Term Weld Factor*—Calculate the short term weld factors for each vertically and horizontally welded specimen as follows:

$$\text{Short Term Weld Factor} = \frac{\text{Weld Strength, psi (MPa)}}{\text{Average Control Strength, psi (MPa)}} \quad (2)$$

9.4 All weld factors of the test specimens shall meet or exceed the values for the type of thermoplastic material listed in Table 2 or as agreed to between the supplier and user. If any specimens fail to meet or exceed the specified values, the welder is not considered certified and shall resubmit newly prepared specimens for retesting. Subsequent failures should call for investigation of the technique and equipment.

10. Report

10.1 Report the following information:

10.1.1 At the time the test specimens are provided for testing, welder shall provide details of weld joint techniques as required in Section 7, which should include profile, type of weld equipment, type of gas and flow rate, temperatures used, type and nominal thickness of plastic sheet and rod, and method of bevel preparation, if any.

10.1.2 Identification of the welder and the date of test specimen fabrication shall be recorded.

10.1.3 Weld strengths of all of the welded specimens, the five control specimens, and the calculated short term weld factors shall be reported.

11. Welder Proficiency

11.1 All welders engaged in the fabrication of structures intended to hold, contain, or convey corrosive chemicals shall be evaluated in accordance with the mandates of this practice.

11.2 To maintain qualification, welders shall, at least once a year, prepare and have tested, according to this practice, test specimens of each combination of plastics and welding equipment for which they wish qualification. Results achieved shall be in accordance with the requirements given in 9.4. Test results shall be maintained in the personnel file of the welder and should be made available to customers upon request.

12. Keywords

12.1 chemical resistant; plastics welding; short term weld factor; thermoplastic; welding

ASTM International takes no position respecting the validity of any patent rights asserted in connection with any item mentioned in this standard. Users of this standard are expressly advised that determination of the validity of any such patent rights, and the risk of infringement of such rights, are entirely their own responsibility.

This standard is subject to revision at any time by the responsible technical committee and must be reviewed every five years and if not revised, either reapproved or withdrawn. Your comments are invited either for revision of this standard or for additional standards and should be addressed to ASTM International Headquarters. Your comments will receive careful consideration at a meeting of the responsible technical committee, which you may attend. If you feel that your comments have not received a fair hearing you should make your views known to the ASTM Committee on Standards, at the address shown below.

This standard is copyrighted by ASTM International, 100 Barr Harbor Drive, PO Box C700, West Conshohocken, PA 19428-2959, United States. Individual reprints (single or multiple copies) of this standard may be obtained by contacting ASTM at the above address or at 610-832-9585 (phone), 610-832-9555 (fax), or service@astm.org (e-mail); or through the ASTM website (www.astm.org).