



Designation: C 1154 – 9902

Standard Terminology for Non-Asbestos Fiber-Reinforced Cement Products¹

This standard is issued under the fixed designation C 1154; the number immediately following the designation indicates the year of original adoption or, in the case of revision, the year of last revision. A number in parentheses indicates the year of last reapproval. A superscript epsilon (ϵ) indicates an editorial change since the last revision or reapproval.

¹ This terminology is under the jurisdiction of ASTM Committee C-17 on Fiber-Reinforced Cement Products and is the direct responsibility of Subcommittee C17.91 on Editorial and Terminology.

Current edition approved Nov. 10, 1999; 2002. Published ~~December 1999~~; November 2002. Originally published as C 1154-90. Last previous edition C 1154-98d⁹.

1. Scope

1.1 This standard covers definitions pertaining to non-asbestos fiber-reinforced cement products under the jurisdiction of Committee C-17.

2. Referenced Documents

2.1 ASTM Standards:

C 150 Specification for Portland Cement²

C 428 Specification for Asbestos-Cement Nonpressure Sewer Pipe³

C 618 Specification for Coal Fly Ash and Raw or Calcined Natural Pozzolan for Use as a Mineral Admixture in Concrete⁴

C 966 Guide for Installing Asbestos-Cement Nonpressure Pipe³

C 1185 Test Methods for Sampling and Testing Non-Asbestos Fiber-Cement Flat Sheet, Roofing and Siding Shingles, and Clapboards³

C 1186 Specification for Flat Non-Asbestos Fiber-Cement Sheets³

D 1118 Test Method for Magnetic Rating of Asbestos Fiber and ~~Products~~ Asbestos Textiles³

3. Terminology

accessories, *n*—subordinate material such as fasteners, backer strips, closure strips, ridge and corner rolls, roofing starters and finishing pieces, couplings, gaskets, pipe fittings or other supplementary material necessary for the proper application of primary fiber-reinforced cement products.

American method, *n*—*in shingles*, a method of application for roofing shingles, generally rectangular in shape, to provide double coverage with head lap and no side lap.

AOQL, *n*—The average outgoing quality limit of a sampling plan is the maximum value of the proportion defective accepted on average by that plan. AOQL is the maximum value of the multiplicand of the proportion nonconforming and the probability of acceptance from the sampling plan operating characteristic.

asphalt felt, breather type, *n*—an underlayment sheet material saturated with asphalt, which allows the transmission of water vapor.

autoclaved products, *n*—those that have been treated in a saturated steam atmosphere at between 620 and 1517 kPa (90 and 220 psi,) for at least 6 h, and that contain portland cement as defined in Specifications C 150 and C 618 together with silica in the ratio of 3:2 that can react to form calcium silicate reaction products.

backer strips, *n*—*in shingles*, water-repellent strips of asphalt-coated felt applied behind each joint where the vertical edges of two shingles meet.

batten, *n*—a long narrow strip, either flat or corrugated, used to conceal the joints in butt joint application of flat or corrugated sheets.

caulking, *n*—a material ranging in physical characteristics from plastic, to solid, to preformed, used to seal and waterproof joints and overlaps in structures, other assemblies, or portions thereof where movement may occur.

cement-bonded particle board, *n*—manufactured flat sheets of hydraulic cementitious matrices and fibrous wood particles.

clip, *n*—*in shingles*—See **storm anchor**.

² Annual Book of ASTM Standards, Vol 04.01.

³ Annual Book of ASTM Standards, Vol 04.05.

⁴ Annual Book of ASTM Standards, Vol 04.02.

- closure strip**, *n*—an asphalt or rubber preformed filler strip having the same shape and pitch as the corrugated product, used to close openings in the corrugated sheets at window beads, eaves, lower edge of siding, and similar places.
- compacted backfill**, *n*— *in pipe laying*, backfill material which has been compacted to the density specified by the engineer.
- conduit**, *n*—pipe used to protect wires for electric-power or communication systems, for both underground and exposed situations.
- constructor**, *n*— *in pipe laying*, the party that furnishes the work and materials for placement and installation.
- corner rolls**, *n*—half-round units used to trim and flash corners in corrugated application.
- corrugated**, *adj*—pertaining to a sheet product having a design of sinusoidal alternating ridges and valleys manufactured according to a specific pitch.
- coupling**, *n*—*in nonpressure sewer pipe*, a section for joining nonpressure sewer pipe, that when properly installed with the proper accessories, develops an assembled joint equivalent in serviceability and strength to the pipe sections, when tested in accordance with 8.3 of Specification C 428.
- crushing strength**, *n*— *for pipes*, a property of solid material that indicates its ability to withstand collapse from external, compressive loads.
- cure**, *n*—the reaction mechanism in which the physical, chemical and mechanical properties of a hydraulic cement change through the phases of slurry-paste-solid with time, with or without external heat, in the presence of water.
- cure, air or ambient**, *n*—the method of setting or hardening products wherein the portland cement is allowed to hydrate at atmospheric conditions of pressure, preferably under conditions to inhibit water and heat loss.
- cure, autoclave**, *n*—a means for accelerating the cure reaction at elevated temperature and pressure in saturated steam, where reactive siliceous material has been incorporated into the cementitious matrix, such that a hydrothermal reaction takes place between the cement and silica yielding calcium silicate.
- curing agent**, *n*—an additive incorporated in the constituents of products producing a change in chemical activity between the cementitious components with an increase or decrease in the rate of cure.
- deflection**, *n*—the linear distance that a test specimen bends at the center from no load to stated load, when loaded as a beam with the load applied at the center of the span.
- density**, *n*—mass per unit volume expressed in g/cm^3 or lb/ft^3 .
- drawings**, *n*—*in pipe laying*, drawings prepared by the purchaser to show the location and details for the construction of the pipeline and appurtenances.
- Dutch or Scotch method**, *n*— *in shingles*, a method of application for roofing shingles which are rectangular in shape and lap at the top and one side to form either a square or rectangular pattern.
- efflorescence (bloom)**, *n*—a white powdery substance occurring on the surface of products and caused by the migration of soluble salts, followed by precipitation of calcium hydroxide at the surface followed by an atmospheric carbonation.
- engineer**, *n*—*in pipe laying*, the person, firm, corporation, or government agency acting for the owner as his duly authorized agent in the designing and engineering of the project.
- fiber**, *n*—*in fiber-cement*, any material in a form such that it has a minimum length to average maximum transverse dimension of 10 to 1, a maximum cross-sectional area of $5.06 \times 10^{-2} \text{ mm}^2$ (corresponding to a circular cross section of 0.254 mm in diameter) and a maximum transverse dimension of 0.254 mm.
- fiber**, *n*—*in fiber-reinforced cement*, any material in a form such that it has an aspect ratio of at least 10 and a typical transverse dimension less than 2 mm.
- fiber-cement products**, *n*—manufactured thin section composites of hydraulic cementitious matrices and discrete non-asbestos fibers.
- fiber-mat reinforced products**, *n*— manufactured thin section composites of hydraulic cementitious matrices and non-asbestos fibers in two-dimensional scrim(s).
- fiber-reinforced**, *adj*—imparting improved properties to hydraulic cement matrices due to the inclusion of fibers.
- fibrous**, *adj*—pertaining to, consisting of, or containing fibers.
- filler**, *n*—an inert inorganic material used as an extender or mineral diluent in the constituents of products which does not add to the cementitious value of the cement.
- fitting**, *n*—*for pipes*, component such as wyes, tees, and adaptors for use in laying pipe, such that, when properly installed yields an assembly equivalent in serviceability and strength to the pipe sections.
- fitting**, *n*—*for conduit*, component such as adapters, reducers, increasers, bends and bell ends, for use in laying conduit and made to such dimensions as will provide equivalent strength and silt-tight joints when assembled with the conduit.
- flat sheets, Type A**, *n*—sheet intended for exterior applications, where it may be subjected to the direct action of sun, rain, or snow, and when tested in accordance with Test Methods C 1185, does demonstrate compliance with Specification C 1186.
- flat sheets, Type B**, *n*—sheet intended for exterior applications where it will not be subjected to the direct action of sun, rain, or snow, and when tested in accordance with Test Methods C 1185, does demonstrate compliance with Specification C 1186.
- flexural strength**, *n*— *in bulkheading*, the transverse breaking load in newtons per meter of width (lbf/ft of width) of saturated sheets when loaded on a span of 1.524 m (5 ft) with the load applied equally and simultaneously at both one-third points of the span.
- flexural strength**, *n*— *in plastic-foam core insulating panels*, the average breaking load in newtons (or lbf) of specimens

conditioned at 50 % relative humidity, loaded as simple beams with the load applied equally and simultaneously at both one-third points of the span.

flexural strength, *n*— in flat sheet, the average breaking load in newtons (or lbf) per metre (foot) of width of dried specimens loaded as simple beams on a span of 254 mm (10 in.) with the load applied at the center of the span.

flexural strength, *n*— in corrugated sheets, the average breaking load in newtons per meter of width (or lbf-ft of width) of dried specimens loaded as simple beams on a 762-mm (30-in.) span with the load applied equally and simultaneously at both one-third points of the span.

DISCUSSION—The flexural performance is defined as the moment capacity in N·m/m (or ft·lbf/ft) of width obtained from the product of flexural strength and span divided by 6.

flexural strength, *n*— in pipe, the ability of a standard pipe longitudinal section to withstand external loads that bear on the pipe transversely to its longitudinal axis and induce bending.

free lime, *n*—uncombined calcium hydroxide.

French or hexagonal method, *n*—in shingles, a method of application for asbestos-cement roofing, whereby the shingles have at least three corners clipped so that when they are laid with their diagonals perpendicular to the eave of the roof, they lap at the top and sides to form a hexagonal pattern.

grade, *n*—subdivision of flat sheets based on minimum wet and equilibrium flexural strengths.

granules, *n*—small ceramic or natural colored mineral pellets or grains applied to products to lend color to the surface.

headlap, *n*—in shingles, the shortest distance between the lower edge of an overlapping shingle or sheet and the upper edge of the lapped unit in the second course below (see Fig. 1).

hip and ridge, finishing pieces, *n*—in shingles, rectangular pieces of roofing shingles cut to a flare or taper and applied with a side lap to conceal the joint of roofing shingles along the hips and ridge of a roof.

hydrostatic strength, *n*— in pipes, the ability of the pipe and coupling sleeve to withstand the forces resulting from internal pressure.

inspector, *n*—in pipe laying, an authorized representative of the engineer, or owner, assigned to make any and all necessary inspections of the work performed, including materials and equipment furnished.

lap cement, *n*—the cementitious material used to seal the side and end laps of corrugated roofing.

lot, *n*—in conduit, each 1000 lengths of conduit or less, of a given class, type and size manufacture on each machine during a 24-h period.

lot, *n*—in nonpressure sewer pipe, for pipe sizes 150 mm (6 in.) and smaller, those lengths of pipe of that size, class and type manufactured during the same work shift. For pipe sizes 200 mm (8 in.) through 525 mm (21 in.), each 300 lengths of pipe or less, of identical size, class, and type manufactured on each machine during a 24-h period. For pipe sizes larger than 525 mm (21 in.) each 300 lengths of pipe or less, of identical size, class, and type manufactured on each machine during a period of consecutive working days not exceeding seven days.

lot, *n*—in underdrain pipe, each 400 m (1300 ft) of pipe or less of a given type and size manufactured on each machine during a 24-h period.

louver blade, *n*—a shaped asbestos-cement product used to guard ventilation ports.

manufacturer, *n*—the party that manufactures, fabricates, or produces materials or products.

owner, *n*—in pipe laying, the person, firm, corporation, or government agency entering into contract with the contractor for the installation of pipe and accessories.

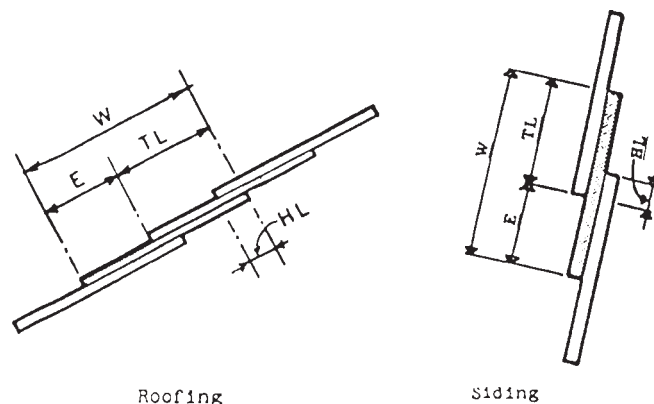

Terminology
 E—Exposure
 TL—Toplap
 HL—Head lap
 W—Width for strip shingles or length for individual shingles

FIG. 1 Examples of Overlap

package unit, *n*— *in pipe laying*, several units of pipe bound together for the purpose of being transported and, when desired, unloaded at the job site.

pitch, *n*—*in cooling tower fill*, the wave length of corrugated products.

plans and specifications, *n*—*in pipe laying*, documents prepared by the engineer or owner, or both, stipulating work to be done and materials to be used which, combined with other contract documents and Guide C 966, form the basis for a comprehensive contract between the owner and the contractor.

pressed products, *n*— *in cooling tower fill*, includes those that are pressed singly or in stacks interlayered with templates, at a minimum pressure of 12 MPa (1740 psi).

purchaser, *n*—*in pipe laying*, the person, company, or organization that purchases any materials or work to be performed.

ranch type, *adj*— *in shingles*, pertaining to a type of roofing, rectangular in shape, that is lapped at the top and one side.

ridge roll, *n*—a half-round section applied along the hips and ridge of a roof to conceal and waterproof the apex joint of the roofing material.

side lap, *n*—the shortest horizontal distance between the exposed side edge of a course of roofing or siding material and the nearest underlying area of roof deck or side wall not covered by the preceding adjacent course.

silica, *n*—pulverized silicon dioxide (SiO₂) used as a filler or a part of the cementitious material.

slater's cement, *n*—a type of caulking compound, usually gray in color, and used to cover exposed bolt heads or at the side and end laps of corrugated roofing and in other places where water-resistant putty-like material is desired.

slope, *n*—*in roofing*, the incline of a roof expressed as a ratio of the height in millimetres (inches) of vertical rise per horizontal distance in metres (feet).

standard, primary, *n*—one whose calibration is determined by measurement according to specified parameters.

standard, secondary, *n*—standard calibrated by reference to another standard such as a primary, reference, laboratory, or working standard.

starters, *n*—*in shingles*, lateral sections of roofing shingles applied beneath the first course of shingles with slight overhang at the eaves.

storm anchor (clip), *n*— *in shingles*, a corrosion-resistant metal fastener with a flat base and a shank that fastens the concealed lower corner of each shingle to the exposed edge of the adjacent shingle.

supplier, *n*—*in pipe laying*, the party who supplies material or services. A supplier may or may not be the manufacturer.

test specimen, *n*—the specific portion of a test sample upon which a test is to be performed, and that is obtained by systematically reducing the size of the sample until a representative specimen of the required mass is obtained.

texture, *n*—a surface pattern as compared with a smooth finish.

textured products, *n*— *in cooling tower fill*, those with bas-relief motifs that extend the external surface of a sheet sufficiently to increase its heat transfer capacity by at least 10 % under conditions of turbulent flow.

thermal resistance, R, *n*—the difference in temperature which will develop under a given steady state heat flow between two parallel unit area surfaces for a given material thickness.

toplap, *n*—the shortest distance between the lower edge of an overlapping shingle or sheet, and the upper edge of the lapped unit in the first course below (see Fig. 1).

uncombined calcium hydroxide, *n*— the content of unreacted calcium hydroxide that remains in the sample of cured product when tested.

underdrain, *n*—a type of pipe having a multiplicity of perforations along its length, intended for use in surface or below-surface drainage.

vener, *n*—the decorative surface of a shingle or sheet, usually pigmented or granuled for color.

viewing conditions, *n*—the conditions under which a visual observation is made, including the angular substance of the specimen at the eye; the geometric relationship of source, specimen and eye; the photometric and spectral character of the field of view surrounding the specimen; and the state of adaptation of the eye.

warping, *n*—change or deformation in the original flatness of an asbestos-cement product.

water-repellent substances, *n*—*in shingles*, materials such as waxes, soaps, or silicones which render the surface of shingles more water repellent.

4. Keywords

4.1 chrysotile; color; definitions; fiber-cement; fibers; non-asbestos fiber-cement; pipe; products; terminology; terms^{5,6,7}

⁵ Commission Internationale de l'Éclairage (International Commission on Illumination). The CIE color-order system is the most important of those used in connection with instruments for color measurement.

⁶ Detailed information on the preparation of calibration standards is available from ASTM Headquarters. Request Adjunct No. 12-411180-00 to Test Method D 1118.

⁷ Tristimulus filters are described in the following reference: Lih, M. M., "Color Technology", *Chemical Engineering*, Vol 75, No. 17, August 12, 1968, p. 146 – 156.

This standard is subject to revision at any time by the responsible technical committee and must be reviewed every five years and if not revised, either reapproved or withdrawn. Your comments are invited either for revision of this standard or for additional standards and should be addressed to ASTM International Headquarters. Your comments will receive careful consideration at a meeting of the responsible technical committee, which you may attend. If you feel that your comments have not received a fair hearing you should make your views known to the ASTM Committee on Standards, at the address shown below.

This standard is copyrighted by ASTM International, 100 Barr Harbor Drive, PO Box C700, West Conshohocken, PA 19428-2959, United States. Individual reprints (single or multiple copies) of this standard may be obtained by contacting ASTM at the above address or at 610-832-9585 (phone), 610-832-9555 (fax), or service@astm.org (e-mail); or through the ASTM website (www.astm.org).