



Designation: C 1196 – 92 (Reapproved 1997)

AMERICAN SOCIETY FOR TESTING AND MATERIALS  
100 Barr Harbor Dr., West Conshohocken, PA 19428  
Reprinted from the Annual Book of ASTM Standards. Copyright ASTM

# Standard Test Method for In Situ Compressive Stress Within Solid Unit Masonry Estimated Using Flatjack Measurements<sup>1</sup>

This standard is issued under the fixed designation C 1196; the number immediately following the designation indicates the year of original adoption or, in the case of revision, the year of last revision. A number in parentheses indicates the year of last reapproval. A superscript epsilon ( $\epsilon$ ) indicates an editorial change since the last revision or reapproval.

## 1. Scope

1.1 This test method covers the determination of the average compressive stress in existing unreinforced solid-unit<sup>2</sup> masonry. This test method concerns the measurement of in-situ compressive stress in existing masonry by use of thin, bladder-like flatjack devices that are installed in saw cut mortar joints in the masonry wall. This test method provides a relatively non-destructive means of determining masonry properties in place.

1.2 The values stated in inch-pound units are to be regarded as the standard. The values given in parentheses are for information only.

1.3 *This standard does not purport to address all of the safety concerns, if any, associated with its use. It is the responsibility of the user of this standard to establish appropriate safety and health practices and determine the applicability of regulatory limitations prior to use.*

## 2. Referenced Documents

### 2.1 ASTM Standards:

E 74 Practice for Calibration of Force Measuring Instruments for Verifying the Load Indication of Testing Machines<sup>3</sup>

## 3. Summary of Test Method

3.1 When a slot is formed in the masonry, compressive stress at that point will cause the masonry above and below the slot to move together. Compressive stress in the masonry may be measured by inserting a flatjack into the slot and increasing its internal pressure until the original distance between points above and below the slot is restored. The state of compressive stress in the masonry is approximately equal to the flatjack pressure multiplied by factors which account for the physical characteristics of the jack and the ratio of (a) the bearing area of the jack in contact with the masonry to (b) the bearing area of the slot.

<sup>1</sup> This test method is under the jurisdiction of ASTM Committee C-15 on Manufactured Masonry Units and is the direct responsibility of Subcommittee C15.04 on Research.

Current edition approved March 15, 1992. Published May 1992.

<sup>2</sup> Solid-unit masonry is that built with stone, concrete, or clay units whose net area is equal to or greater than 75 % of the gross area.

<sup>3</sup> *Annual Book of ASTM Standards*, Vol 03.01.

## 4. Significance and Use

4.1 Stress is applied as pressure over the area of the flatjack. In the case of multi-wythe masonry, stress is estimated only in the wythe in which the flatjack is inserted. Stress in other wythes may be different.

## 5. Apparatus

### 5.1 Flatjack:

5.1.1 A flatjack is a thin envelope-like bladder with inlet and outlet ports which may be pressurized with hydraulic oil. Flatjacks may be of any shape in plan, and are designed to be compatible with the masonry being tested. Typically configurations are shown in Fig. 1.

5.1.2 For determination of the state of compressive stress, dimension A should be equal to or greater than the length of a single masonry unit, but not less than 8 in. Dimension B should be equal to or greater than the thickness of one wythe and not less than three in. (76 mm). The radius,  $R$ , for circular and semi-rectangular flatjacks shall be equal to the radius of the circular saw blade used to cut the slot.

5.1.3 Flatjacks shall be made of metal or other material such that the flatjack in a slot in masonry will be capable of applying operating pressures up to 1000 psi (6.9 MPa).<sup>4</sup> Metal flatjacks suitable for this purpose shall be made of type 304 stainless steel sheet of 0.024 in. (0.61 mm) to 0.048 in. (1.2 mm) in thickness with welded seams along the edges and incorporating hydraulic inlet or outlet ports.

5.1.4 Calibrate all flatjacks as described in Section 7 to determine their pressure-applied load characteristics.

5.2 *Hydraulic System*—An electrically or manually operated hydraulic pump with hydraulic hoses is required. Hose connections shall fit the flatjack inlet port. Measure pressure using gages calibrated to a traceable standard having both an accuracy of 1 % of full hydraulic scale and an appropriate operating range. The hydraulic system shall be capable of maintaining constant pressure within 1 % of full scale for at least 5 min.

5.3 *Displacement Measurement*—Measure displacements of the masonry by a mechanical gage extensometer which measures the distance between fixed gage points on the

<sup>4</sup> A maximum operating pressure of 1000 psi (6.9 MPa) is adequate for older existing masonry, but flatjacks with higher operating pressures may be required for more recently constructed buildings.

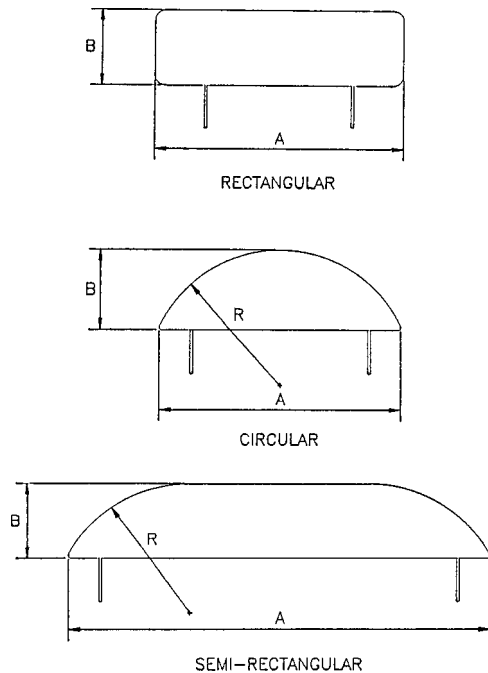

**FIG. 1 Flatjack Configurations**

masonry as shown in Fig. 2. The method or device used to measure deformations shall be capable of deformation measurements up to  $\frac{3}{16}$  in. (5 mm). Deformation measurements shall have an accuracy of at least  $\pm 0.005\%$  of gage length.

**5.4 Gage Points**—Use adhered metal discs or embedded metal inserts as gage points during the measurement process. Attach gage points securely to the masonry (using a rigid adhesive for discs or cementitious grout for plugs) which will prevent movement and ensure the required measurement accuracy. The gage points shall have a conical depression at their center, compatible with the pointed elements of the extensometer. The angles of the depression of the cone and the extensometer points shall be the same.

**6. Preparation of Slots**

**6.1** Slots in masonry are normally prepared by removing the mortar from masonry bed joints to avoid disfiguring the masonry. Remove all mortar in the bed joint, so that pressure exerted by a flatjack shall be directly against the cleaned surfaces of the masonry units.

**6.2** The plan geometry of the slot shall be similar to that of the flatjack being used. Plan dimensions of the prepared slot shall not exceed those of the flatjack by more than  $\frac{1}{2}$  in. (12 mm).

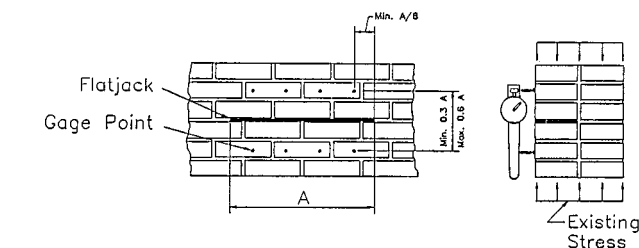

**FIG. 2 Flatjack Test Setup for In Situ Stress Measurement**

**6.3 Slots:**

**6.3.1** Rectangular slots into which rectangular flatjacks are to be inserted may be formed by drilling adjacent or overlapping holes (stitch drilling) and subsequently using a drill, bar, or tool to remove mortar and produce a slot of desired dimensions with smooth upper and lower surfaces.

**6.3.2** Cut slots for circular and semi-rectangular flatjacks using circular saws of sufficient radius to provide the depth required (Fig. 1, dimension B). Use carbide or diamond tipped blades to remove all mortar from the slot.

**7. Calibration**

**7.1** A flatjack has an inherent stiffness which resists expansion when the jack is pressurized. Therefore, the fluid pressure in the flatjack is greater than the stress the flatjack applies to masonry. A flatjack must be calibrated to provide a conversion factor,  $K_m$ , to relate internal fluid pressure to stress applied.

**7.2** Calibrate flatjacks in a compression machine of at least 100 kip capacity which has been calibrated according to Practice E 74.

**7.3** Place a 2 in. (50 mm) thick steel bearing plate on the lower platen of the compression machine. The bearing plate shall be of sufficient size to completely cover the flatjack being calibrated. Place the flatjack on the lower bearing plate such that the edge of the flatjack with the inlet/outlet ports is coincident with the edge of the bearing plate. Place steel spacers around the other edges of the flatjack. The thickness of the spacers shall be equal to approximately  $1\frac{1}{3}$  times the combined thickness of the two steel sheets used in fabrication. Place the upper 2 in. (50 mm) thick bearing plate on top of the shims and flatjack, and align it to be directly above the lower bearing plate. Position the bearing plate/flatjack/shim assembly on the lower platen such that the centroid of the area of the flatjack is within  $\frac{1}{4}$  in. (6 mm) of the axis of thrust of the test machine. The calibration setup is illustrated in Fig. 3.

**7.4** Raise the moveable platen such that the non-moveable platen is in contact with the top bearing plate. Apply a pre-load sufficient to provide full contact between the bearing plates and the spacers, equivalent to 10 psi over the gross area of the flatjack.

**7.5** The distance between platens must be held constant during the calibration procedure. Fix the displacement of the test machine at this point if using a displacement controllable machine. If not, attach displacement gages (mechanical or electrical) such that the distance between platens established by the procedures of paragraph 7.4 can be held constant when using a force-control test machine.

**7.6** Pressurize and depressurize the flatjack three cycles with the maximum pressure in the flatjack not to exceed 1000 psi (2.069 MN/m<sup>2</sup>) nor the stress applied to the flatjack by the compression machine to exceed 1000 psi (2.069 MN/m<sup>2</sup>) based on the gross area of the flatjack.

**7.7** Increase the pressure in the flatjack in 50 to 100 psi (344.8 to 689.5 KN/m<sup>2</sup>) increments up to 1000 psi  $\pm$  50 psi (6.895 MN/m<sup>2</sup>  $\pm$  344.8 KN/m<sup>2</sup>) while holding the distance between platens constant. At each increment, record flatjack hydraulic pressure and force measured by the test machine.

**7.8** Calculate the load applied by the flatjack as internal pressure times gross flatjack area. Plot flatjack load versus load

ASTM C 1196

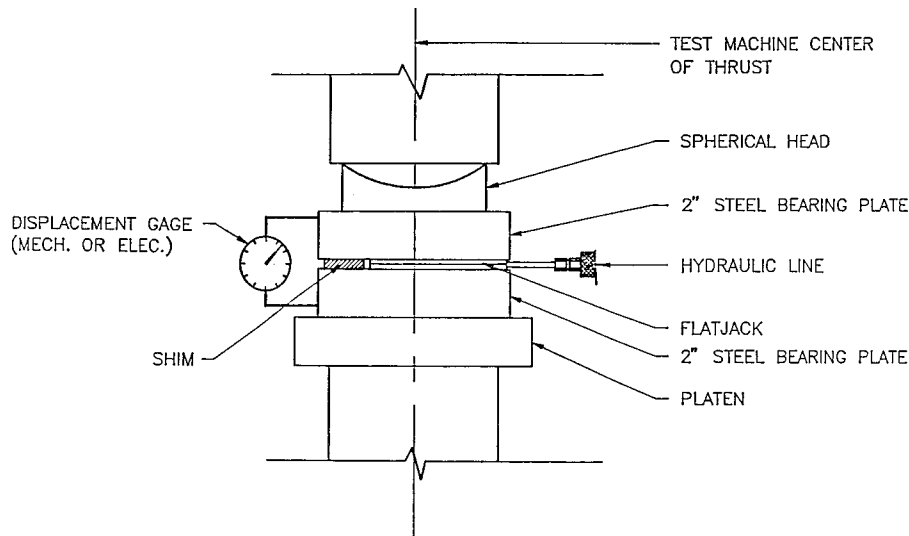

FIG. 3 Flatjack Calibration Setup

measured by the test machine with the flatjack load on the horizontal axis of the plot. The slope of the line is equal to the flatjack constant, that is, the conversion factor:

$$K_m = P_{\text{machine}} \div P_{\text{flatjack}} \quad (1)$$

7.9 Recalibrate flatjacks after using five times or when distortion appears excessive.

**8. Procedure**

8.1 The location at which compressive stress estimates are performed is dictated by engineering objectives. The basic arrangement is illustrated in Fig. 2. At the desired location or locations the following steps should be taken:

8.2 Select and mark a visible line on the masonry to define the location and length of slots to be formed.

8.3 Attach at least four pairs of equally spaced gage discs or embedded plugs vertically aligned above and below the slot as shown in Fig. 2. Each row of gage points thus formed shall be equally spaced above and below the flatjack. The minimum gage length shall be 0.3 times the length, *A*, where *A* is the length of the flatjack as shown in Fig. 1. The maximum gage length shall be 0.6 times the length, *A*, of the flatjack. The first and last locations shall be located not less than 1/8 of dimension *A* inward toward the center of the slot from each end, as shown in Fig. 2.

8.4 Measure the initial distance between each pair of gage points.

8.5 Prepare the slot<sup>5</sup> (see Section 6) and record the measured slot dimensions and the time. Clean slots of all mortar and brick particles prior to the insertion of flatjacks.

8.6 Repeat step 8.4 after the slot has been prepared to obtain the initial deviation from the original gage distances.

8.7 Insert the flatjack into the slot. Shim as required to achieve a tight fit and bridge over any interior voids in the masonry. See the Annex for a description of flatjack shims and their use.

8.8 Connect hydraulic hoses and fill the calibrated flatjack with hydraulic oil until pressure begins to develop.

8.9 In order to *seat* the flatjack and any shims, pressurize the flatjack to approximately 50 % of the estimated maximum flatjack pressure (which corresponds to the estimated compressive stress in the masonry). Reduce the flatjack pressure to zero.

8.10 Increase pressure in the flatjack to 25 %, 50 %, and 75 % of the estimated maximum pressure holding the pressure steady at each level. At each increment, measure and record the distance between each pair of gage points. Three repetitions of displacement measurement are required at each gage point. It is recommended that the test be conducted as soon as possible after formation of the slot: the time taken for load application shall be approximately equal to the time elapsed since formation of the slot to minimize the effects of creep deformations.

8.11 Continue pressurizing until the original gage distances are restored. The allowable average deviation from the original gage length shall be the greater of ±0.0005 in. or 1/20th of the maximum initial deviation, with no single deviation exceeding the greater of ±0.001 in. or 1/10th of the maximum deviation. Tests in which these limits are exceeded shall be considered invalid. Record the final flatjack pressure.

8.12 Reduce the flatjack pressure to zero.

8.13 A second repetition of 8.10 and 8.11 is recommended to verify the final flatjack pressure.

8.14 Disconnect hoses and remove the flatjack. The slot may be filled with mortar or other suitable material of a color and strength similar to the original mortar.

**9. Calculation**

9.1 Calculate the average compressive stress in the masonry, *f<sub>m</sub>*, as:

$$f_m = K_m K_d p \quad (2)$$

where:

<sup>5</sup> The location of the slot shall be at least 1 1/2 flatjack lengths from wall openings or ends.

 C 1196

- $K_m$  = a dimensionless constant which reflects the geometrical and stiffness properties of the flatjack, as determined by Section 7,
- $K_a$  = the ratio of measured area of the flatjack to the average measured area of the slot, and
- $p$  = flatjack pressure required to restore the gage points to the distance initially measured between them within the tolerance allowed, psi or MPa.

## 10. Report

- 10.1 Report each in situ stress determination including the following information:
  - 10.2 Description of the testing conditions, for example, site, geographical location, environmental conditions, (for example, temperature), building identification, date of construction (if available), and name of the engineer/technician conducting the test. Include details of the type and quality of construction.
  - 10.3 Identity and description of the specific test location in the structure and reason for the test.
  - 10.4 Description and sources (if possible) of the masonry materials at the test location including a general condition statement, an elevation drawing, and other pertinent material data.
  - 10.5 Method of forming the slot, a diagram of the slot, adjacent masonry, location of gage points, and all pertinent dimensions.
  - 10.6 Description and source of the flatjack used,

- instrumentation, hydraulic system, flatjack installation, that is, use of shims, and other pertinent information.
- 10.7 Data sheets listing measurements taken at each pressure level.
- 10.8 The pressure at which the initial gage length was restored.
- 10.9 Flatjack calibration factor,  $K_m$ , and derivation.
- 10.10 Flatjack/slot area ratio,  $K_a$ , and calculation.
- 10.11 Magnitude of compressive stress and calculation.
- 10.12 Other observations.

## 11. Precision and Bias

- 11.1 The test data which is available shows the coefficient of variation of this test method to be as great as 20 % and it is recommended that a minimum of three tests be conducted in the same general area to verify test results. Additional data is being assembled to verify the precision of the test method.
- 11.2 Laboratory studies have shown that the in situ stress test exhibits no inherent bias in predicting the state of compressive stress present in the masonry, that is, the method may over or under estimate the actual compressive stress.

## 12. Keywords

- 12.1 compressive stress; flatjack; in situ; masonry; nondestructive evaluation

## ANNEX

### (Mandatory Information)

#### A1. FLATJACK SHIMS

A1.1 The use of shims may be necessary during testing to achieve a tight fit of the flatjack in the slot and to ensure uniform transfer of pressure (stress) to the masonry over the complete area of the flatjack. Excessive deformations of the flatjack will cause inaccurate test results and could change the flatjack calibration factor  $K_m$ . Also it may be difficult to remove the flatjack from the slot after testing if it has deformed into voids. Grouting of the flatjack in the slot is not allowed, as the grout from the slot would flow into voids and cracks, altering the local behavior of the masonry.

A1.2 Three types of shims may be used: single piece shims, multiple piece shims, and fluid cushion shims.

A1.2.1 *Single Piece Shims*—Stiff metal shims having the same shape and size as the flatjack can be used to span voids in the masonry (see Fig. A1.1). Single piece shims should be placed between the flatjack and the irregular masonry surface, and should be of sufficient thickness such that the flatjack fits tightly in the slot. To avoid damage to the flatjack after testing, it is recommended that the single piece shim be removed from the slot before attempting to remove the flatjack.

A1.2.2 *Multiple Piece Shims*—Metal shims made of several pieces can be used if the slot is irregular or of nonuniform

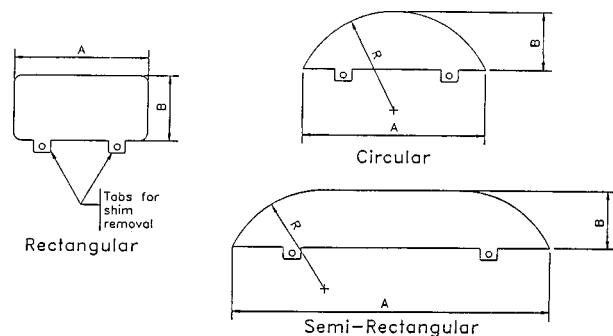

FIG. A1.1 Single Piece Shims

thickness over its length (see Fig. A1.2). The individual pieces must fit tightly together and, in the case of an irregular slot, shall be of sufficient thickness to ensure a tight fit of the flatjack over its entire area. To avoid damage to the flatjack after the completion of testing, it is recommended that the multiple piece shims be removed from the slot before the flatjack is removed.

A1.2.3 *Fluid Cushion Shims*—Additional flatjacks, of

ASTM C 1196

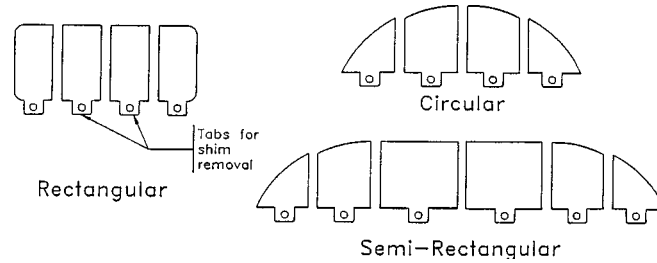

FIG. A1.2 Multiple Piece Shims

geometry identical to the working flatjack,<sup>6</sup> may be used as fluid shims. The fluid shim or shims should be inserted adjacent to the working flatjack, against the surface of the masonry. It may be necessary to use more than one fluid shim if the slot is thick in order to ensure a tight fit of the working flatjack in the slot. In this case, install fluid shims above and

below the working flatjack. The fluid shims are seated initially by pressurizing to 75 to 80 % of the maximum predicted masonry in situ compressive strength. This allows the shim to deform into voids and irregularities in the slot. The shim pressure should be reduced to 5 to 10 psi and the hydraulic line closed before proceeding with the test. After completion of the test, remove the working flatjack and the fluid cushion shim(s) from the slot.

<sup>6</sup> A *working flatjack* is one used in the test to estimate in situ stress and is the active flatjack as opposed to flatjacks used as fluid shims.

*The American Society for Testing and Materials takes no position respecting the validity of any patent rights asserted in connection with any item mentioned in this standard. Users of this standard are expressly advised that determination of the validity of any such patent rights, and the risk of infringement of such rights, are entirely their own responsibility.*

*This standard is subject to revision at any time by the responsible technical committee and must be reviewed every five years and if not revised, either reapproved or withdrawn. Your comments are invited either for revision of this standard or for additional standards and should be addressed to ASTM Headquarters. Your comments will receive careful consideration at a meeting of the responsible technical committee, which you may attend. If you feel that your comments have not received a fair hearing you should make your views known to the ASTM Committee on Standards, 100 Barr Harbor Drive, West Conshohocken, PA 19428.*