



Standard Practice for Installing Vitrified Clay Pipe Lines¹

This standard is issued under the fixed designation C 12; the number immediately following the designation indicates the year of original adoption or, in the case of revision, the year of last revision. A number in parentheses indicates the year of last reappraisal. A superscript epsilon (ε) indicates an editorial change since the last revision or reappraisal.

This standard has been approved for use by agencies of the Department of Defense.

1. Scope

1.1 This practice covers the proper methods of installing vitrified clay pipe lines in order to fully utilize the structural properties of such pipe.

1.2 The values stated in inch-pound units are to be regarded as the standard. The values given in parentheses are for information only.

1.3 *This standard does not purport to address all of the safety concerns, if any, associated with its use. It is the responsibility of the user of this standard to establish appropriate safety and health practices and determine the applicability of regulatory limitations prior to use.*

2. Referenced Documents

2.1 ASTM Standards:

- C 301 Test Methods for Vitrified Clay Pipe²
- C 425 Specification for Compression Joints for Vitrified Clay Pipe and Fittings²
- C 700 Specification for Vitrified Clay Pipe, Extra Strength, Standard Strength, and Perforated²
- C 828 Test Method for Low-Pressure Air Test of Vitrified Clay Pipe Lines²
- C 896 Terminology Relating to Clay Products²
- C 1091 Test Method for Hydrostatic Infiltration and Exfiltration Testing of Vitrified Clay Pipe Lines²

3. Terminology

3.1 *General*—Terminology C 896 can be used for clarification of terminology in this specification.

DESIGN CONSIDERATIONS

4. Supporting Strength

4.1 The field supporting strength of vitrified clay pipe is materially affected by the methods of installation. The field supporting strength of a pipe is defined as its capacity to

support dead and live loads under actual field conditions. It is dependent upon two factors: (1) the inherent strength of the pipe and (2) the bedding of the pipe.

4.2 The minimum bearing strength requirement in accordance with Specification C 700, as determined by the 3-edge-bearing test of Test Methods C 301, is a measure of the inherent strength of the pipe.

4.3 The tests used to measure bearing strength determine relative pipe strengths but do not represent actual field conditions. Therefore, an adjustment called a load factor is introduced to convert minimum bearing strength to field supporting strength. The magnitude of the load factor depends on how the pipe is bedded. The relationship is:

$$\text{Field supporting strength} = \text{minimum bearing strength} \times \text{load factor}$$

4.4 A factor of safety greater than 1.0 and less than or equal to 1.5 shall be applied to the field supporting strength to calculate a safe supporting strength. The relationship is:

$$\text{Safe supporting strength} = \frac{\text{Field supporting strength}}{\text{Factor of safety}}$$

5. External Loads

5.1 The external loads on installed vitrified clay pipe are of two general types: (1) dead loads and (2) live loads.

5.2 For pipes installed in trenches at a given depth, the dead load increases as the trench width, measured at the top of the pipe, increases. Consequently, the trench width at the top of the pipe shall be kept as narrow as possible. Pipe failure may result if the design trench width is exceeded. If the trench width exceeds the design width, a higher class of bedding, stronger pipe, or both, must be investigated.

5.3 Live loads that act at the ground surface are partially transmitted to the pipe. Live loads may be produced by wheel loading, construction equipment or by compactive effort. Compaction of embedment and backfill materials, beside and above the sewer pipe, produces a temporary live load on the pipe. The magnitude of the live load from compactive effort varies with soil type, degree of saturation, degree of compaction and depth of cover over the pipe. Care must be used in selection of compaction methods so that the combined dead load and live load does not exceed the field supporting strength of the pipe, or cause a change in its line or grade.

¹ This practice is under the jurisdiction of ASTM Committee C04 on Vitrified Clay Pipe and is the direct responsibility of Subcommittee C04.20 on Methods of Test and Specifications.

Current edition approved February 10, 2003. Published June 2003. Originally approved in 1915. Last previous edition approved in 2001 as C 12–01.

² *Annual Book of ASTM Standards*, Vol 04.05.

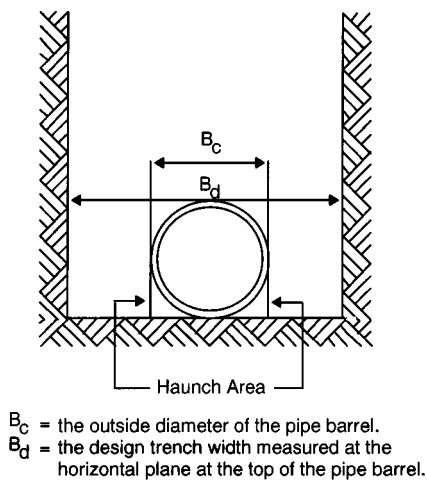
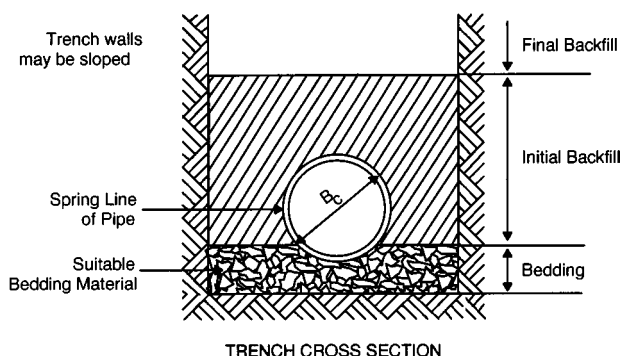
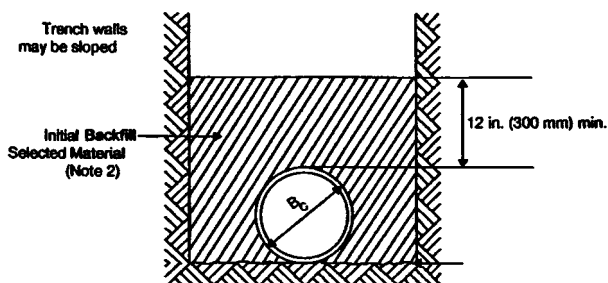

FIG. 1 Terminology



Load Factor: 1.1
 Flat or Restored Trench Bottom

FIG. 2 Class D

NOTE 1—For generally accepted criteria and methods for determining loads and supporting strengths, see *Gravity Sanitary Sewer Design and Construction, Water Pollution Control Federation Manual of Practice No. FD-5, American Society of Civil Engineers—Manuals and Report on Engineering Practice—No. 60*.³

6. Bedding and Encasement

6.1 Classes of bedding and encasements for pipe in trenches are defined herein. The load factors indicated are for conversion of minimum bearing strength to field supporting strength.

6.2 *Class D* (Fig. 2)—The pipe shall be placed on a firm and unyielding trench bottom with bell holes provided (Fig. 9). The initial backfill shall be of selected material (Note 2).

6.2.1 The load factor for Class D bedding is 1.1.

NOTE 2—Selected material is finely divided material free of debris, organic material, and large stones.

6.3 *Class C* (Fig. 3)—The pipe shall be bedded in suitable material (Note 3 and Note 4). Where suitable material is not available, other materials approved by the engineer, shall be used. The bedding shall have a minimum thickness beneath the pipe of 4 in. (100 mm) or one eighth of the outside diameter of the pipe, whichever is greater, and shall extend up the haunches of the pipe one sixth of the outside diameter of the pipe. The initial backfill shall be of selected material (Note 2).

6.3.1 The load factor for Class C bedding is 1.5.

NOTE 3—Suitable material is well-graded $\frac{3}{4}$ to $\frac{1}{4}$ in. (19 to 6 mm) crushed stone, having a minimum of one fractured face, or other angular, non-consolidating bedding material not subject to migration. Well-graded angular, non-consolidating bedding materials are more stable than rounded bedding materials of equal gradation. Material shall be shovel-sliced so the material fills and supports the haunch area and encases the pipe to the limits shown in the trench diagrams (Figs. 3-6 and Fig. 8).

NOTE 4—Sand is suitable as a bedding material in a total sand environment but may be unsuitable where high and rapidly changing water tables are present in the pipe zone. It may also be undesirable for bedding, or haunching in a trench cut by blasting or in trenches through clay type soil. Regardless of the trench condition or bedding class, the maximum load factor for sand bedding is 1.5.

6.4 *Class B* (Fig. 4)—The pipe shall be bedded in suitable material (Note 3). The bedding shall have a minimum thickness beneath the pipe of 4 in. (100 mm) or one eighth of the outside diameter of the pipe, whichever is greater, and shall extend up the haunches of the pipe to the springline. The initial backfill shall be of selected material (Note 2).

6.4.1 The load factor for Class B bedding is 1.9.

6.5 *Crushed Stone Encasement* (Fig. 5)—There are specific sites where crushed stone encasement may be desirable. The crushed stone shall extend to the specified trench width and shall have a minimum thickness beneath the pipe of 4 in. (100 mm) or one eighth of the outside diameter of the pipe, whichever is greater, and shall extend upward to a horizontal plane at the top of the pipe barrel (see Note 5). Encasement shall consist of well-graded $\frac{3}{4}$ to $\frac{1}{4}$ in. (19 to 6 mm) crushed stone or other non-consolidating bedding material not subject to migration. Material shall be carefully placed into the pipe haunches (Note 3). The initial backfill shall be of selected material (Note 2).

NOTE 5—Sufficient crushed stone or other suitable material (Note 3) shall be placed so that the bedding extends to a horizontal plane at the top of the pipe barrel following removal of any trench sheeting or boxes.

6.5.1 The load factor for crushed stone encasement is 2.2.

6.6 *Controlled Low Strength Material* (Fig. 6)—Controlled low strength material has been shown to be an economic alternative to compacted bedding material. It assists in utilizing the inherent strength of the pipe, completely filling the haunch area, and reducing the trench load on the pipe.

6.6.1 The pipe shall be bedded on crushed stone or other suitable material (Note 3 and Note 4). The bedding shall have

³ Available from American Society of Civil Engineers, 1801 Alexander Bell Dr., Reston, VA 20191.

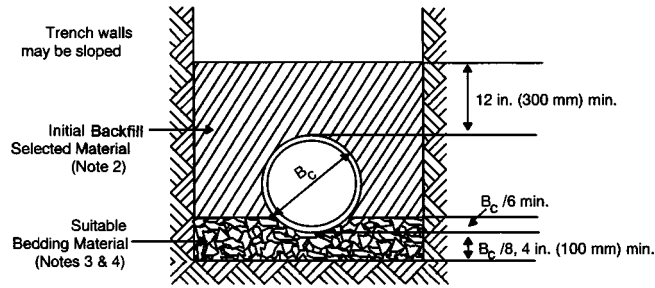

Load Factor: 1.5
FIG. 3 Class C

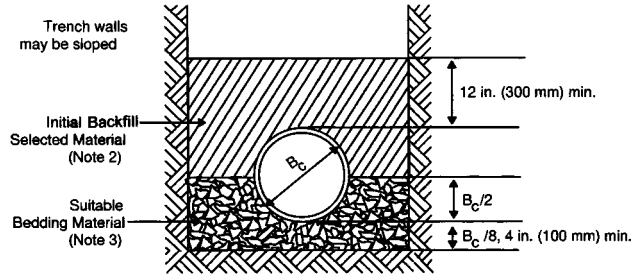

Load Factor: 1.9
FIG. 4 Class B

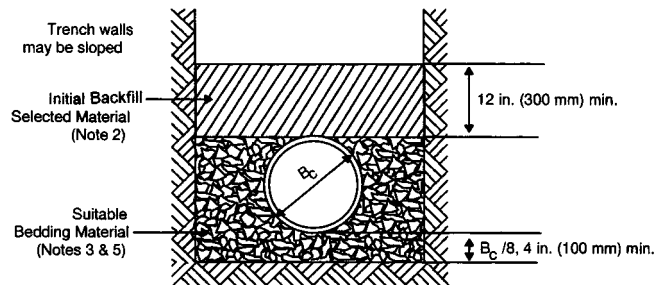

Load Factor: 2.2
FIG. 5 Crushed Stone Encasement

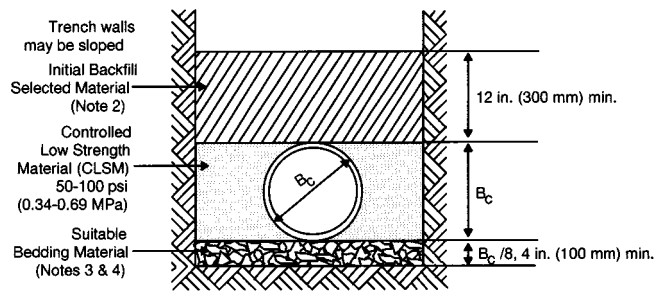

Load Factor: 2.8

NOTE 1—This type of construction requires the fill to extend from the pipe to the trench wall, not to extend above the top of the pipe or below the bottom of the pipe. Where native soils are expansive, further investigation may be necessary.

FIG. 6 Controlled Low Strength Material (CLSM)

a minimum thickness beneath the pipe of 4 in. (100 mm) or one eighth of the outside diameter of the pipe, whichever is greater. Controlled low strength material shall be directed to the top of the pipe to flow down on both sides to prevent misalignment.

Fill to the top of the pipe. The initial backfill may be placed when the pour is capable of supporting the backfill material without intermixing.

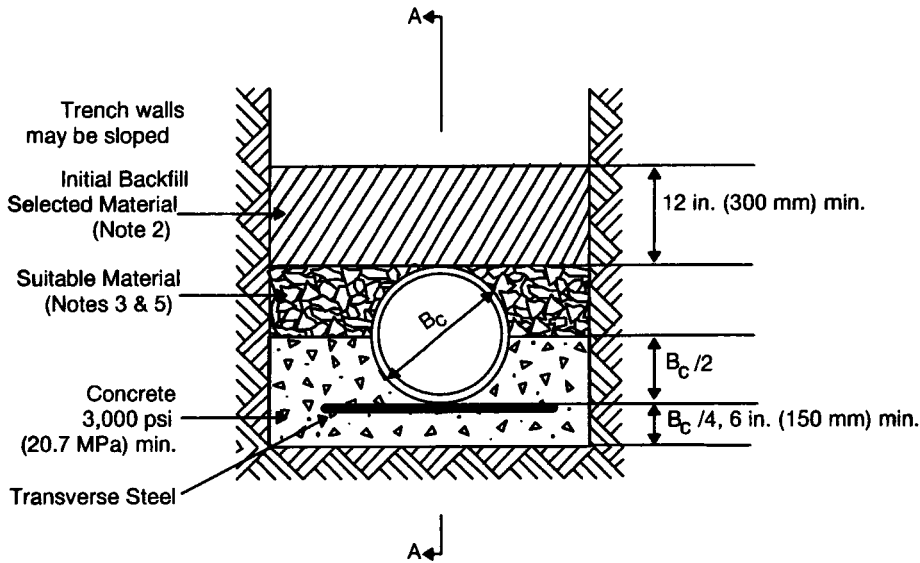

Load Factor: 3.4 Reinforced Concrete $p = 0.4\%$

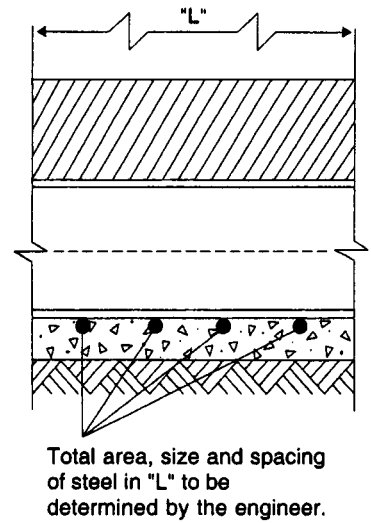

SECTION A-A

NOTE 1—Minimum width of concrete cradle: $B_c + 8$ in. (200 mm) or $1\frac{1}{4} B_c$.

NOTE 2— p is the ratio of the area of steel to the area of concrete. (It is recommended that wire mesh reinforcement or uniformly distributed small diameter rebar be used in all concrete design.)

FIG. 7 Concrete Cradle

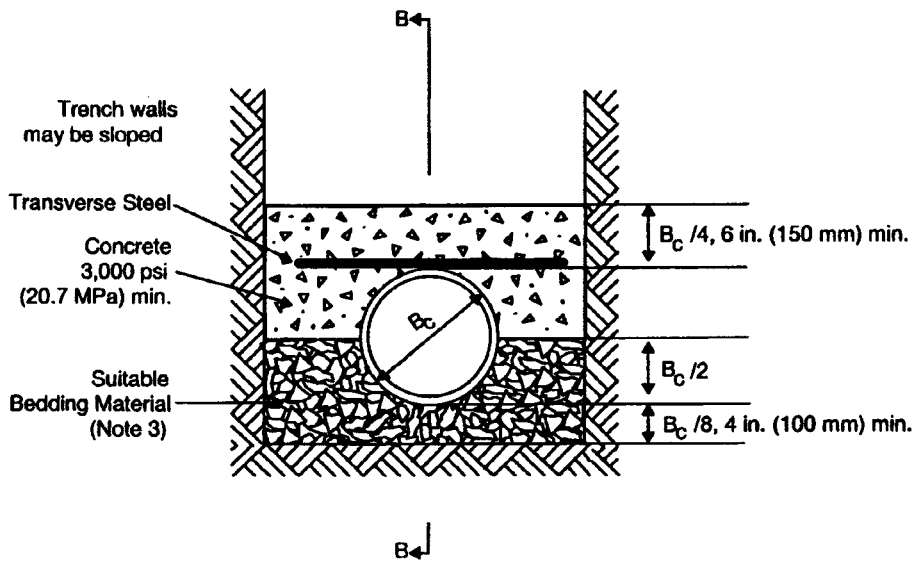

Load Factor: 3.4 Reinforced Concrete $p = 0.4\%$
4.5 Reinforced Concrete $p = 1.0\%$

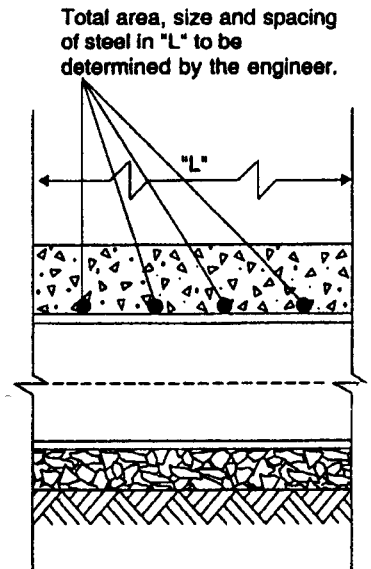

SECTION B-B

NOTE 1—Minimum width of concrete arch: $B_c + 8$ in. (200 mm) or $1\frac{1}{4} B_c$.

NOTE 2— p is the ratio of the area of steel to the area of concrete. (It is recommended that wire mesh reinforcement or uniformly distributed small diameter rebar be used in all concrete design.)

FIG. 8 Concrete Arch

NOTE 6—Attention is directed to terminology and material references.
See *American Concrete Institute Report: ACI 229R-94 Controlled Low*

Provide uniform and continuous support of pipe barrel between bell or coupling holes.

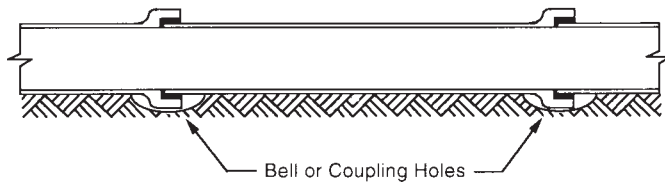

FIG. 9 Uniform Pipe Support

Strength Materials (CLSM).⁴

6.6.2 The load factor for controlled low strength material is 2.8.

6.7 *Class A*—This class of bedding can be achieved with either of two construction methods.

6.7.1 *Concrete Cradle* (Fig. 7)—The pipe shall be bedded in a monolithic cradle of reinforced concrete having a thickness under the barrel of at least 6 in. (150 mm) or one fourth of the outside diameter of the pipe, whichever is greater, and extending up the haunches to a height of at least one half the outside diameter of the pipe. The cradle width shall be at least equal to the outside diameter of the pipe plus 4 in. (100 mm) on each side or one and one fourth times the outside diameter of the pipe, whichever is greater. If the trench width is greater than either of these dimensions, concrete may be placed to full trench width. Suitable material shall extend upward to a horizontal plane at the top of the pipe barrel. The initial backfill shall be selected material.

6.7.1.1 The load factor for Class A concrete cradle bedding is 3.4 for reinforced concrete with $p = 0.4\%$, where p is the percentage of the area of transverse steel to the area of concrete at the bottom of the pipe barrel as shown in Fig. 7.

6.7.2 *Concrete Arch* (Fig. 8)—The pipe shall be bedded in suitable material (Note 3). The bedding shall have a minimum thickness beneath the pipe of 4 in. (100 mm) or one eighth of the outside diameter of the pipe, whichever is greater, and shall extend up the haunches of the pipe to the springline. The top half of the pipe shall be covered with monolithic reinforced concrete arch with a minimum thickness from the top of the pipe barrel, of 6 in. (150 mm) or one fourth of the nominal diameter of the pipe, whichever is greater. The width of the arch shall be at least equal to the outside diameter of the pipe plus 4 in. (100 mm) on each side, or one and one fourth times the outside diameter, whichever is greater. If the trench width is greater than either of these dimensions, concrete may be placed to full trench width.

6.7.2.1 The load factor for Class A concrete arch bedding is 3.4 for reinforced concrete with $p = 0.4\%$, and up to 4.8 for reinforced concrete with $p = 1.0\%$, where p is the percentage of the area of transverse steel to the area of concrete above the top of the pipe barrel as shown in Fig. 8.

6.8 *Concrete Encasement:*

6.8.1 There are specific sites where concrete encasement may be desirable. Concrete encasement shall completely surround the pipe and shall have a minimum thickness, at any point, of one fourth of the outside diameter of the pipe or 4 in. (100 mm), whichever is greater.

6.8.2 The encasement shall be designed by the engineer to suit the specific use.

CONSTRUCTION TECHNIQUES

7. Trench Excavation

7.1 Trenches shall be excavated to a width that will provide adequate working space, but not more than the maximum design width. Trench walls shall not be undercut.

7.2 The trench walls can be sloped to reduce trench wall failure. This sloping will not increase the load on the pipe provided the measured trench width at top of pipe does not exceed the design trench width.

7.3 Trenches, other than for Class D bedding, shall be excavated to provide space for the pipe bedding.

7.4 Sheet, shore, and brace trenches, as necessary, to prevent caving or sliding of trench walls, to provide protection for workmen and the pipe, and to protect adjacent structures and facilities.

7.5 Sheeting shall not be removed below the top of the pipe if the resulting slope of native soil increases the trench width to such an extent that the load on the pipe exceeds the safe field supporting strength of the pipe and bedding system.

7.6 When a movable box is used in place of sheeting or shoring, secure the installed pipe to prevent it from moving when the box is moved.

7.7 It is preferable to keep the trench dry during all phases of construction. Exercise caution when terminating the dewatering procedure to avoid disturbing the pipe installation.

8. Trench Foundation

8.1 The trench foundation is the area below the pipe and bedding which supports the pipe bedding structure.

8.2 The trench foundation shall be firm and unyielding.

9. Pipe Bedding

9.1 Bell holes shall be excavated to prevent point loading of the bells or couplings of laid pipe, and to establish full-length support of the pipe barrel (Fig. 9).

9.2 Bedding shall be placed so that the pipe is true to line and grade and to provide uniform and continuous support of the pipe barrel.

10. Pipe Handling

10.1 Pipe and fittings shall be handled carefully to protect from damage.

10.2 Carefully examine each pipe and fitting before installation, for soundness and specification compliance. Pipe accepted may be plainly marked by the inspector. Rejected pipe shall not be defaced, but shall be replaced with pipe that meets specification.

10.3 Handle pipe so that premolded jointing surfaces or attached couplings do not support the weight of the pipe. Do

⁴ Available from American Concrete Institute, P.O. Box 9094, Farmington Hills, MI 48333.

TABLE 1 Joint Deflection Limits

NOTE 1—For calculating the minimum radius of curvature use the following:
 pipe—3 in. (75 mm) to 12 in. (305 mm) Diameter radius = 24 × pipe length
 pipe—15 in. (380 mm) to 24 in. (610 mm) Diameter radius = 32 × pipe length
 pipe—27 in. (685 mm) to 36 in. (915 mm) Diameter radius = 48 × pipe length
 pipe—39 in. (990 mm) to 42 in. (1065 mm) Diameter radius = 64 × pipe length

NOTE 2—Material is applicable to compression joints for vitrified clay pipe and fittings in accordance with Specification C 425.

Nominal Diameter, in. (mm)	Maximum Angular Deflection per Joint, degrees	Maximum Deflection of Pipe, in./linear ft (mm/linear m)
3–12 (75–305)	2.4°	½ (42)
15–24 (380–610)	1.8°	¾ (31)
27–36 (685–915)	1.2°	¼ (21)
39–42 (990–1065)	0.9°	⅜ (16)

not damage the jointing surfaces or couplings by dragging, contact with hard materials, or by use of hooks.

11. Pipe Laying

11.1 Clean joint contact surfaces immediately prior to joining. Use joint lubricants and joining methods, as recommended by the pipe manufacturer.

11.2 Unless otherwise required, lay all pipe straight between changes in alignment and at uniform grade between changes in grade. Excavate bell holes for each pipe joint. When joined in the trench, the pipe shall form a true and smooth line.

11.3 Straight lengths of pipe may be used for horizontal or vertical curves by uniformly deflecting each joint. The joint deflection limits shall be as described in Table 1.

11.4 Whenever practicable, start pipe laying at the lowest point and install the pipe so that the spigot ends point in the direction of flow to prevent bedding material from entering the joint.

11.5 After each pipe had been brought to grade, aligned, and placed in final position, deposit and shovel slice or spade bedding material under the pipe haunches. Wyes and tees shall be bedded to prevent shear loading.

11.6 Place pipe that is to be bedded in concrete cradle or encased in concrete, in proper position on temporary supports. When necessary, rigidly anchor or weight the pipe to prevent flotation as concrete is placed.

11.7 Place concrete for cradles, arches, or encasement uniformly on each side of the pipe and deposit at approximately its final position. Concrete placed beneath the pipe shall be sufficiently workable so that the entire space beneath the pipe can be filled without excessive vibration.

11.8 Where pipe connects with outside faces of manhole walls or the outside faces of the walls of other structures, provide a pipe joint such that slight flexibility or motion can take place in or near the plane of the wall face. It is recommended that a 12 to 18 in. (300 to 450 mm) pipe stub be extended from manhole or other wall faces. The pipe stub shall be bedded in the same manner as the pipe.

12. Backfilling Trenches

12.1 Initial backfill need not be compacted to develop field supporting strength of the pipe. Final backfill may require compaction to prevent settlement of the ground surface.

12.2 Unless otherwise directed, backfill trenches as soon as practicable after the pipe is laid. In the case of concrete bedding, delay backfilling until the concrete has set sufficiently to support the backfill load.

12.3 The initial backfill shall be of selected material (Note 2). Final backfill shall have no rock or stones having a dimension larger than 6 in. (150 mm) within 3 ft. (0.9 m) of the top of the pipe.

12.4 Puddling, jetting, or water flooding may be used for consolidating backfill material only when approved by the engineer.

13. Field Performance and Acceptance

13.1 After installation the sewer shall be tested for integrity by a method specified or approved by the engineer.

13.2 Where ground water exists, the line may be tested for infiltration by determining the quantity of water entering the system during a specified time period. Infiltration testing is recommended and shall conform to the test procedure described in Test Method C 1091.

13.3 Where ground water does not exist, either a water or low-pressure air test method may be used and shall be specified. The exfiltration test shall conform to the test procedure described in Test Method C 1091. Air testing shall conform to the test procedure described in Test Method C 828, and is recommended.

NOTE 7—When water or air tests are specified and the acceptance of a line depends upon satisfactory results, it should be recognized that several factors have a bearing on these results. Manhole bases, walls, and seals must be watertight. Household and commercial building and roof drains must be isolated. Stoppers must be sufficiently secured to be air or watertight.

13.4 In order for the performance of the line to be acceptable, all tests shall be made on pipe laid in accordance with the bedding provisions of Section 6. Joining procedures shall follow the recommendation of the pipe manufacturer.

14. Keywords

14.1 backfilling; bedding; clay pipe; compaction; construction; design; excavation; installation; load factors; perforated pipe; pipe; sewers; trench foundation; trenching; vitrified

APPENDIX

(Nonmandatory Information)

X1. INSTALLATION CRITERIA FOR PERFORATED VITRIFIED CLAY PIPE

X1.1 *Position of Perforations:*

X1.1.1 Perforations in a subdrain or leachate pipe shall normally be down.

X1.1.2 Under unique conditions it may be desirable to place the perforations up.

X1.2 *Method of Design:*

X1.2.1 Design in accordance with standard engineering practice, noting particularly, the bearing strength as listed in Specification C 700.

X1.3 *Bedding and Backfill:*

X1.3.1 Bedding and backfill shall be in accordance with the engineer's design.

X1.3.2 It is desirable to contain the bedding with a filter fabric.

X1.3.3 In the pipe zone the material shall be free draining without migration.

X1.3.4 Extreme care should be exercised in placement and compaction of backfill.

ASTM International takes no position respecting the validity of any patent rights asserted in connection with any item mentioned in this standard. Users of this standard are expressly advised that determination of the validity of any such patent rights, and the risk of infringement of such rights, are entirely their own responsibility.

This standard is subject to revision at any time by the responsible technical committee and must be reviewed every five years and if not revised, either reapproved or withdrawn. Your comments are invited either for revision of this standard or for additional standards and should be addressed to ASTM International Headquarters. Your comments will receive careful consideration at a meeting of the responsible technical committee, which you may attend. If you feel that your comments have not received a fair hearing you should make your views known to the ASTM Committee on Standards, at the address shown below.

This standard is copyrighted by ASTM International, 100 Barr Harbor Drive, PO Box C700, West Conshohocken, PA 19428-2959, United States. Individual reprints (single or multiple copies) of this standard may be obtained by contacting ASTM at the above address or at 610-832-9585 (phone), 610-832-9555 (fax), or service@astm.org (e-mail); or through the ASTM website (www.astm.org).