



Designation: C 1208/C 1208M – 00

# Standard Specification for Vitrified Clay Pipe and Joints for Use in Microtunneling, Sliplining, Pipe Bursting, and Tunnels<sup>1</sup>

This standard is issued under the fixed designation C 1208/C 1208M; the number immediately following the designation indicates the year of original adoption or, in the case of revision, the year of last revision. A number in parentheses indicates the year of last reappraisal. A superscript epsilon (ε) indicates an editorial change since the last revision or reappraisal.

## 1. Scope

1.1 This specification establishes the criteria for the manufacture, quality assurance testing, inspection, installation, field acceptance testing, and product marking of vitrified clay pipe to be used in microtunneling, sliplining, pipe bursting, in casings, and in tunnels for the conveyance of sewage, industrial wastes, and storm water.

1.1.1 Sections 4-7 and 9 of this specification contain manufacturing, quality assurance testing, inspection, and product marking criteria which are applicable to vitrified clay pipe prior to installation.

1.1.2 Section 8 of this specification contains criteria for the installation and field acceptance testing of vitrified clay pipe.

1.2 This specification also covers materials and test requirements for jointing of the pipe.

1.3 The values stated in either inch-pound units or SI units are to be regarded separately as standard. Within the text, the SI units are shown in brackets. The values stated in each system are not exact equivalents; therefore, each system shall be used independently of the other. Combining values from the two systems may result in nonconformance with the specification.

1.4 *This standard does not purport to address all of the safety concerns, if any, associated with its use. It is the responsibility of the user of this standard to establish appropriate safety and health practices and determine the applicability of regulatory limitations prior to use.*

## 2. Referenced Documents

### 2.1 ASTM Standards:

C 67 Test Methods of Sampling and Testing Brick and Structural Clay Tile<sup>2</sup>

C 301 Test Methods for Vitrified Clay Pipe<sup>2</sup>

C 828 Test Method for Low-Pressure Air Test of Vitrified Clay Pipe Lines<sup>2</sup>

C 896 Terminology Relating to Clay Products<sup>2</sup>

C 1091 Test Method for Hydrostatic Infiltration and Exfil-

<sup>1</sup> This specification is under the jurisdiction of ASTM Committee C04 on Vitrified Clay Pipe and is the direct responsibility of Subcommittee C04.20 on Methods of Test and Specifications.

Current edition approved Aug. 10, 2000. Published September 2000. Originally published as C 1208 – 91 and C 1208M – 91. Last previous edition C 1208/C 1208M – 99a.

<sup>2</sup> *Annual Book of ASTM Standards*, Vol 04.05.

tration Testing of Vitrified Clay Pipe Lines<sup>2</sup>

D 395 Test Methods for Rubber Property—Compression Set<sup>3</sup>

D 412 Test Methods for Vulcanized Rubber and Thermoplastic Rubbers and Thermoplastic Elastomers—Tension<sup>3</sup>

D 471 Test Method for Rubber Property—Effect of Liquids<sup>3</sup>

D 518 Test Method for Rubber Deterioration—Surface Cracking<sup>3</sup>

D 543 Test Method for Resistance of Plastics to Chemical Reagents<sup>4</sup>

D 573 Test Method for Rubber—Deterioration in an Air Oven<sup>3</sup>

D 1149 Test Method for Rubber Deterioration—Surface Ozone Cracking in a Chamber<sup>3</sup>

D 2240 Test Method for Rubber Property—Durometer Hardness<sup>3</sup>

## 3. Terminology

3.1 *Definitions*— Terminology C 896 can be used for clarification of terminology in this specification.

### PIPE

## 4. Materials and Manufacture

4.1 Vitrified clay pipe shall be manufactured from fire clay, shale, surface clay, or a combination of these materials that, when formed into pipe and fired to suitable temperatures, yields a product that conforms to this specification.

### 4.2 Test Requirements for Pipe:

#### 4.2.1 Test Samples:

4.2.1.1 When requested, test samples representative of the pipe to be used shall be selected by the purchaser or his representative from the supplier's stock.

4.2.1.2 The number of samples to be tested shall not exceed 0.5 % of the number of pipe of each size furnished, except that no less than three samples shall be tested.

4.2.1.3 If any of the test samples fail to meet the requirements of 4.2.2-4.2.5, the manufacturer will be allowed to retest two additional samples representative of the original material for each one that failed. The pipe will be acceptable if all retest

<sup>3</sup> *Annual Book of ASTM Standards*, Vol 09.01.

<sup>4</sup> *Annual Book of ASTM Standards*, Vol 08.01.

**TABLE 1 Three Edge Bearing Strength**

Nominal Diameter, in.	Bearing Strength, lb/linear ft
4	2000
6	2000
8	2200
10	2400
12	2600
15	2900
18	3300
21	3850
24	4400
27	4700
30	5000
36	6000
42	7000

**TABLE 2 Three Edge Bearing Strength [SI]**

Nominal Diameter, mm	Bearing Strength, kN/m
100	29
150	29
200	32
250	35
300	38
400	42
500	52
600	64
700	69
800	77
900	88
1000	96
1100	105

**TABLE 3 Hydrostatic Pressure Test Time**

Barrel Thickness, in.	Test Time, min
Up to and including 1	7
Over 1 including 1.5	9
Over 1.5 including 2	12
Over 2 including 2.5	15
Over 2.5 including 3	18
Over 3	21

**TABLE 4 Hydrostatic Pressure Test Time [SI]**

Barrel Thickness, mm	Test Time, min
Up to and including 25	7
Over 25 including 38	9
Over 38 including 50	12
Over 50 including 64	15
Over 64 including 76	18
Over 76	21

4.2.3.7 The bearing surface of the test samples shall be ground to planes, parallel within 0.002 in. (0.05 mm). The use of capping material is not permitted.

4.2.3.8 Apply the load up to 3500 psi [25 MPa]. The remaining required load is applied at the uniform rate in not less than 1 min nor more than 2 min.

4.2.3.9 Calculate and report the compressive strength as follows:

$$\text{Compressive Strength, } C = W/A \quad (1)$$

where:

$C$  = compressive strength of the specimen, lbf/in.<sup>2</sup> [kgf/cm<sup>2</sup>] to the nearest 100 lbf/in.<sup>2</sup> [0.07 kgf/mm<sup>2</sup>],

$W$  = recorded load, lbf [kgf/mm<sup>2</sup>], indicated by the testing machine, and

$A$  = average of the gross areas of the upper and lower bearing surfaces of the specimen, in.<sup>2</sup> [mm<sup>2</sup>] to the nearest 0.04 in.<sup>2</sup> [25 mm<sup>2</sup>].

#### 4.2.4 Hydrostatic Pressure Test or Absorption Test:

4.2.4.1 The manufacturer shall, at his option, apply either a hydrostatic pressure test or an absorption test to all of the test specimens.

4.2.4.2 *Hydrostatic Pressure Test*—When the pipe is subjected to an internal hydrostatic pressure of 10 psi [70 kPa] for the elapsed time indicated in Tables 3 and 4, there shall be no leakage. Moisture appearing on the surface shall not be considered leakage. However, moisture which starts to run on the pipe shall be construed as leakage, regardless of quantity. At the option of the manufacturer, water within approximately 5°F [3°C] of the ambient air temperature may be introduced into the pipe for control of condensation.

4.2.4.3 *Absorption Test*—The absorption of vitrified clay pipe shall not exceed 8 % when tested in accordance with Test Methods C 301.

#### 4.2.5 Acid Resistance:

4.2.5.1 This test is used to determine the resistance of pipe to the action of acids specified in Test Methods C 301. The test shall be performed only when specified.

4.2.5.2 The pipe of each size and shipment shall be acceptable if the acid-soluble matter, from specimens representing such pipe, does not exceed 0.25 %.

#### 4.3 Sizes and Dimensions:

samples meet the test requirements. If any of the re-test pipe fail, the lot shall be rejected.

4.2.1.4 If, subsequent to an initial test failure, the accuracy of the testing equipment is questioned, at the request of the manufacturer, the equipment shall be recalibrated and a retest made or a retest made using other equipment of known accuracy.

4.2.2 *Bearing Strength*— Pipe shall meet the bearing strength requirements of Tables 1 and 2.

#### 4.2.3 Compressive Strength Test:

4.2.3.1 This test is used to determine the compressive strength of pipe material. This test shall be performed only when specified.

4.2.3.2 Pipe material shall have a minimum compressive strength of 7000 psi [50 MPa].

4.2.3.3 The testing machine shall be of a type having sufficient capacity and capable of providing the rates of loading prescribed. The bearing area from which the force will be applied shall be spherically seated.

4.2.3.4 The specimen shall be a cylinder cut from the pipe so that the length of the specimen is along the longitudinal axis of the pipe. The cylinder shall have a minimum diameter of 1 in. (25 mm) for pipe wall thickness through 2 1/2 in. (65 mm) and 2 in. (50 mm) for greater wall thicknesses and a diameter to length ratio of 1:2. The tolerance of the diameter and length shall be + - 5%. Measurements shall be made to the nearest 0.001 in. (0.025 mm).

4.2.3.5 The test load on the specimen shall be centered axially on the ends of the cylinder.

4.2.3.6 The bearing surfaces of the specimen shall be parallel planes and perpendicular to the vertical axis.

TABLE 5 Dimensions and Variations

Nominal Diameter, in.	Out-of-Straight <sup>A</sup> , in./linear ft, max	Out-of-Round, in., max	Out-of-Square <sup>A</sup> , in., max <sup>B</sup>	Laying Length Minus Tolerance, in./linear ft	Nominal Inside Diameter Minus Tolerance <sup>C</sup> , in.
4	0.05	0.08	0.03	0.25	0.19
6	0.05	0.12	0.04	0.25	0.25
8	0.05	0.16	0.05	0.25	0.31
10	0.05	0.20	0.06	0.25	0.38
12	0.05	0.24	0.08	0.25	0.44
15	0.05	0.30	0.09	0.25	0.56
18	0.05	0.36	0.11	0.25	0.69
21	0.05	0.42	0.13	0.25	0.81
24	0.05	0.48	0.15	0.38	0.94
27	0.05	0.54	0.17	0.38	1.06
30	0.05	0.60	0.19	0.38	1.19
36	0.05	0.72	0.22	0.38	1.44
42	0.05	0.84	0.25	0.38	1.44

<sup>A</sup> See Fig. 1.

<sup>B</sup> These numbers are approximate since they are computed using outside diameter. Consult the pipe manufacturer for specific dimensions.

<sup>C</sup> There is no fixed + tolerance limit.

TABLE 6 Dimensions and Variations [SI]

Nominal Diameter, mm	Out-of-Straight <sup>A</sup> , mm/M, max	Out-of-Round, mm, max	Out-of-Square <sup>A</sup> , mm, max <sup>B</sup>	Laying Length Minus Tolerance, mm/M	Nominal Inside Diameter Minus Tolerance <sup>C</sup> , mm
100	4	2	1	20	5
150	4	3	1	20	6
200	4	4	1	20	8
250	4	5	1	20	10
300	4	6	2	20	12
400	4	8	2	20	16
500	4	10	3	20	20
600	4	12	3	30	24
700	4	14	4	30	28
800	4	16	4	30	32
900	4	18	5	30	36
1000	4	20	5	30	36
1100	4	22	6	30	36

<sup>A</sup> See Fig. 1.

<sup>B</sup> These numbers are approximate since they are computed using outside diameter. Consult the pipe manufacturer for specific dimensions.

<sup>C</sup> There is no fixed + tolerance limit.

4.3.1 Sizes and dimensions of pipe shall conform to the requirements of Tables 5 and 6.

4.3.2 The outside diameter shall not vary from a true circle by more than 2 % of its nominal diameter.

4.3.2.1 The out-of-round dimension is the difference between the maximum and minimum diameters measured at any one location along the pipe barrel.

4.3.3 Pipe shall not deviate from straight by more than 0.05 in./linear ft [4 mm/m] when the maximum offset is measured from the concave side of the pipe. See Fig. 1.

4.3.3.1 Measurements shall be taken by placing a straightedge on the concave side of the full length of the pipe barrel excluding the joint and measuring the maximum distance between the straightedge and concave side of the pipe.

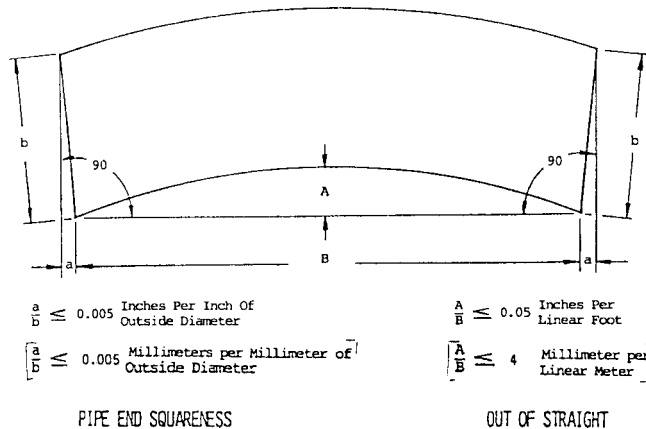

NOTE 1—Illustration is exaggerated to show dimensions.

FIG. 1 Pipe End Squareness and Out of Straight

4.3.4 The plane formed by a pipe end shall not deviate by more than 0.005 in./in. [0.005 mm/mm] of outside diameter when measured in accordance with Fig. 1.

4.3.5 The pipe wall thickness shall be a suitable dimension to adequately distribute the field jacking forces and shall be prescribed by the manufacturer.

4.4 *Fractures, Cracks, and Blisters:*

4.4.1 There shall be no fractures or cracks passing through the barrel, visible to the unaided eye.

4.4.2 Chips, fractures, or blisters on the pipe shall not exceed 2 in. [50 mm] in any surface dimension and shall not exceed a depth of one eighth of the minimum thickness of the barrel.

**JOINTS**

**5. Materials and Manufacture**

5.1 *Principles of Joint Design:*

5.1.1 A typical joint design is indicated in Fig. 2.

5.1.2 Sealing elements shall be compressed between bearing surfaces to ensure watertight integrity as required in 5.3.

5.1.3 Sealing elements may be independent or bonded to a bearing surface.

5.1.4 The ends of the pipe shall incorporate a compression ring to distribute the jacking forces which develop during installation.

5.1.5 The outside diameter of the sleeve shall not vary from the outside diameter of the pipe barrel to the extent that it would restrict the installation during jacking.

5.2 *Requirements:*

5.2.1 Sealing components shall meet the requirements of Table 7.

5.2.2 Sleeves shall be made of a material which in conjunction with the sealing elements, forms a joint which meets the test requirements of 5.3.

5.3 *Test Requirements for Assembled Joints:*

5.3.1 The number of specimens to be tested shall not exceed 0.25 % of the number of pipe of each size furnished. A minimum of one joint shall be tested for each diameter furnished.

5.3.2 The assembled joint shall not leak when tested in accordance with 5.4.

5.4 *Test Methods for Assembled Joints:*

5.4.1 Assemble two pipes and restrain only the amount necessary to prevent longitudinal movement.

5.4.2 Uniformly support and secure one of the pipe. To the other pipe, apply a shear load of 50 lbf/in. [9 N/mm] of nominal diameter uniformly over an arc of not less than 120° (2.1 rad) along a distance of 12 in. [300 mm] adjacent to the joint. See Fig. 3.

5.4.3 Apply an internal 10-ft head (4.3 psi) [30 kPa] of water pressure for a period of 1 h.

**6. Test Methods**

6.1 Perform required tests in accordance with Test Methods C 301 and C 67.

**7. Inspection**

7.1 All pipe is subject to inspection by, and at the option of the purchaser or his representative. Inspection shall be promptly made at the factory or at the point of delivery. All pipe accepted may be plainly marked by the purchaser or his representative. Rejected pipe shall not be defaced, but shall be replaced by the manufacturer or seller without additional cost with pipe that meets the requirements of this specification.

**8. Installation and Field Acceptance Testing**

8.1 The installation of pipe prescribed in this specification should only be performed by contractors familiar with pipe jacking and with equipment specifically designed for this purpose.

8.2 The jacking force shall not exceed the requirements prescribed by the manufacturer and shall include a safety factor acceptable to the design engineer and contractor.

8.3 Care shall be taken to maintain proper alignment during installation.

8.4 When required, field acceptance testing after installation may be performed in accordance with Test Methods C 828 or C 1091.

**9. Product Marking**

9.1 Each length of pipe shall bear the identification of the manufacturer, the location of the plant and the designation ASTM C 1208. The markings shall be indented on the exterior of the pipe, or permanently marked by other means, at the time of manufacture. All markings shall be clearly legible, in order to meet the identification requirements.

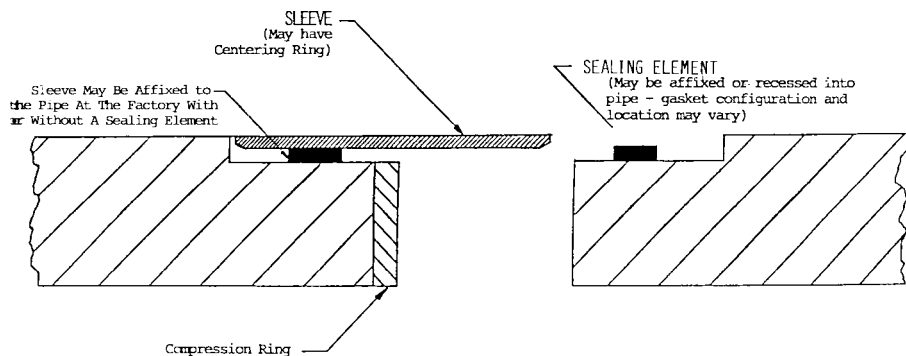

FIG. 2 Typical Joint Design

TABLE 7 Tests for Sealing Components

NOTE—Except for the water absorption test (Test Method D 471), the tests shall be run on buttons or specimens cut from rubber test slabs.

Tests for Rubber Sealing Components		
Test	Test Requirement	ASTM Test Method
Chemical Resistance: 1 N Sulfuric Acid 1 N Hydrochloric Acid	No weight loss No weight loss	D 543 (48 h at 23 ± 2°C)
Tensile Strength	1500 psi [10 MPa] min 500 % elongation at break	D 412
Hardness	Shore A durometer 45 min to 70 max	D 2240
Compression Set	16 % max of original deflection	D 395, Method B (22 h at 70 ± 2°C)
Water Absorption	5 % max	D 471, Immerse a 2-in. [50-mm] long section cut from a rubber sealing element in distilled water for 7 days at 70 ± 2°C
Ozone Resistance	No visible cracking under 2× specimen magnification using Test Method D 518, Procedure B, stretched 20 % and exposed to ozone concentrations of 0.5 ppm for 24 h at 40 ± 1°C	D 1149
Accelerated Oven Aging	80 % min of original tensile strength 75 % min of original elongation	D 573 (7 days at 70 ± 2°C)

Tests for Plastic Sealing Components		
Test	Test Requirements	ASTM Test Method
Chemical Resistance: 1 N Sulfuric Acid 1 N Hydrochloric Acid	No weight loss No weight loss	D 543 (48 h at 23 ± 2°C)

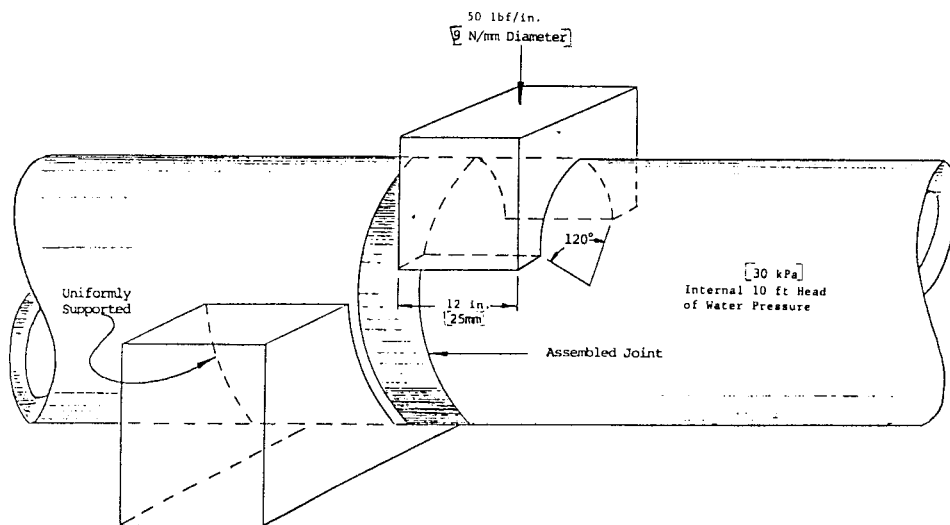

FIG. 3 Joint Shear—Leakage Test Assembly

10. Keywords

10.1 absorption test; acid resistance; bearing strength; bearing surface; chemical resistance; clay pipe; coatings; compression ring; compressive strength; jacking; jacking force; micro-tunneling; ozone resistance; pipe bursting; plane; pressure test; sealing elements; shear; sleeve; sliplining; tunnels

**SUPPLEMENTARY REQUIREMENTS**

These requirements apply only to Federal/Military procurement, not domestic sales or transfers.

**S1. Government/Military Procurement**

S1.1 *Responsibility for Inspection*—Unless otherwise specified in the contract or purchase order, the producer is responsible for the performance of all inspection and test requirements specified herein. The producer may use his own or any other suitable facilities for the performance of the inspection and test requirements specified herein, unless the purchaser disapproves. The purchaser shall have the right to perform any of the inspections and tests set forth in this specification where such inspections are deemed necessary to ensure that material conforms to prescribed requirements.

NOTE S1.1—In U.S. Federal contracts, the contractor is responsible for inspection.

**S2. Packaging and Marking for U.S. Government Procurement**

S2.1 *Packaging*—Unless otherwise specified in the contract, the materials shall be packaged in accordance with the supplier's standard practice in a manner ensuring arrival at destination in satisfactory condition and which will be acceptable to the carrier at lowest rates. Containers and packing shall comply with Uniform Freight Classification rules or National Motor Freight Classification rules.

S2.2 *Marking*—Marking for shipment shall be in accordance with Fed. Std. No. 123 for civil agencies and MIL-STD-129 for military agencies.

NOTE S2.1—The inclusion of U.S. Government procurement requirements should not be construed as an indication that the U.S. Government uses or endorses the products described in this document.

*The American Society for Testing and Materials takes no position respecting the validity of any patent rights asserted in connection with any item mentioned in this standard. Users of this standard are expressly advised that determination of the validity of any such patent rights, and the risk of infringement of such rights, are entirely their own responsibility.*

*This standard is subject to revision at any time by the responsible technical committee and must be reviewed every five years and if not revised, either reapproved or withdrawn. Your comments are invited either for revision of this standard or for additional standards and should be addressed to ASTM Headquarters. Your comments will receive careful consideration at a meeting of the responsible technical committee, which you may attend. If you feel that your comments have not received a fair hearing you should make your views known to the ASTM Committee on Standards, at the address shown below.*

*This standard is copyrighted by ASTM, 100 Barr Harbor Drive, PO Box C700, West Conshohocken, PA 19428-2959, United States. Individual reprints (single or multiple copies) of this standard may be obtained by contacting ASTM at the above address or at 610-832-9585 (phone), 610-832-9555 (fax), or service@astm.org (e-mail); or through the ASTM website (www.astm.org).*