



Standard Test Method for Determination of Glass Fiber Content in Glass Fiber Reinforced Concrete (GFRC) (Wash-Out Test)¹

This standard is issued under the fixed designation C 1229; the number immediately following the designation indicates the year of original adoption or, in the case of revision, the year of last revision. A number in parentheses indicates the year of last reapproval. A superscript epsilon (ϵ) indicates an editorial change since the last revision or reapproval.

1. Scope

1.1 This test method covers determination of the fiber content in an uncured, glass fiber reinforced concrete (GFRC) sample panel.

1.2 *This standard does not purport to address all of the safety concerns, if any, associated with its use. It is the responsibility of the user of this standard to establish appropriate safety and health practices and determine the applicability of regulatory limitations prior to use.*

1.3 The values stated in inch-pound units are to be regarded as the standard. The values given in parentheses are provided for information only.

2. Referenced Documents

2.1 *ASTM Standards:*

C 1228 Practice for Preparing Coupons for Flexural and Washout Tests on Glass Fiber Reinforced Concrete²

3. Terminology

3.1 *Definition:*

3.1.1 *glass fiber reinforced concrete (GFRC)*—a composition of cementitious material, aggregates, water, admixtures, and alkali-resistant glass fiber.

4. Significance and Use

4.1 Glass fiber contents, determined by this test method, are useful for quality control of GFRC products to ensure that manufacturing equipment has been set up to deliver the correct proportions of glass fiber reinforcement in a GFRC composite.

5. Apparatus

5.1 *Balance*, 2 kg capacity, sensitive to the nearest 0.1 g.

5.2 *Mesh Basket or Strainer*, approximately 30 in.³ (493 cm³) capacity of woven stainless steel wire and mesh size between $\frac{3}{16}$ (4.5 mm) and $\frac{1}{16}$ (1.5 mm). Overall dimensions must totally accept the test sample without any overhang, and depth should be approximately twice the thickness of the test

sample. Gage and construction must be such that mesh dimension cannot easily enlarge, allowing glass reinforcement to escape.

5.3 *Drying Chamber*, an oven that can be set at 230°F \pm 10° (110°C \pm 10°), or a muffle furnace set at 900°F \pm 10° (482°C \pm 10°).

5.4 *Razor Knife*, capable of 6 in. blade extension.

5.5 *Splitting Jig*, see Fig. 1.

6. Sampling

6.1 Sampling should be in accordance with governing specifications.

7. Test Specimens

7.1 Cut the coupons with a razor knife from a freshly cast, damp, uncured sample panel. When cutting out the test coupon, the sample panel shall have sufficient cohesiveness such that: (a) a clean cut can be made without pulling out fibers from the test coupon or the adjacent material, and (b) that material is not lost from the test coupon prior to determining mass.

7.2 The test specimen shall be between 12 in.² (78 cm²) and 16 in.² (103 cm²).

8. Procedure

8.1 Cut two test coupons with a razor knife from a freshly produced, damp, uncured sample panel as done in Practice C 1228. Place the coupons in a mesh basket of known mass (W_1) and record the total mass (W_2). The basket and contents are held under a stream of running water and the composite is worked with fingers to break it up. Take care to ensure that no glass is lost. See Fig. 2.

8.2 When all the cement and fine aggregate (if any) are washed away, dry the basket and contents in an oven at 230°F \pm 10° (110°C \pm 10°), (or muffle furnace at 900°F \pm 10° (483°C \pm 10°C) to a constant mass, as determined by taking three measurements at 10 min intervals. After drying, tap the basket of dried glass against the countertop to dislodge adhered sand particles that would induce an error in the glass content measurement. Be careful not to lose any glass particles. The last value of mass is recorded as W_3 , provided it differs from the previous value by less than 0.1 %.

¹ This test method is under the jurisdiction of ASTM Committee C-27 on Precast Concrete Products and is the direct responsibility of Subcommittee C27.40 on Glass Fiber Reinforced Concrete Made by the Spray-Up Process.

Current edition approved Oct. 15, 1994. Published December 1994. Originally published as C 1229 – 93. Last previous edition C 1229 – 93.

² *Annual Book of ASTM Standards*, Vol 04.05.

NOTE 1—Microwave ovens should not be used to dry glass fiber.

NOTE 2—If desired or required, a measure of the glass fiber distribution through the thickness of the coupon can be obtained by repeating the

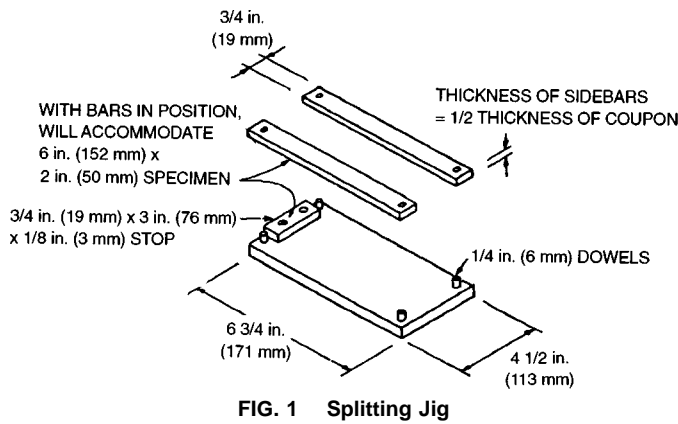

FIG. 1 Splitting Jig

procedure on coupons slit into two halves through the thickness using the splitting jig as shown in Fig. 1. If this is done, the two halves should have approximately equal mass.

8.3 Record the final value of mass as W_3 , provided it differs from the previous weight measurement by less than 0.1 %.

9. Calculations

9.1 Glass fiber content in a washout coupon is calculated as follows:

$$\text{glass fiber content} = \frac{W_3 - W_1}{W_2 - W_1} \times 100 \quad (1)$$

where:

- W_1 = mass of basket, g,
- W_2 = mass of basket plus coupon, g, and
- W_3 = mass of basket plus glass (after drying), g.

Record mass change to the nearest 0.1 percent of original mass.

NOTE 3—If the procedure in Note 2 is followed, the glass fiber distribution through the thickness can be calculated by measuring the glass fiber contents in the two split halves and expressing them (to the nearest 0.1) as a top to bottom ratio.

Top to bottom ratio

$$= \frac{\text{glass fiber content in top, \%}}{\text{glass fiber content in the bottom, \%}} \quad (2)$$

10. Precision and Bias

10.1 Precision—The precision of this test method is being determined.

The American Society for Testing and Materials takes no position respecting the validity of any patent rights asserted in connection with any item mentioned in this standard. Users of this standard are expressly advised that determination of the validity of any such patent rights, and the risk of infringement of such rights, are entirely their own responsibility.

This standard is subject to revision at any time by the responsible technical committee and must be reviewed every five years and if not revised, either reapproved or withdrawn. Your comments are invited either for revision of this standard or for additional standards and should be addressed to ASTM Headquarters. Your comments will receive careful consideration at a meeting of the responsible technical committee, which you may attend. If you feel that your comments have not received a fair hearing you should make your views known to the ASTM Committee on Standards, 100 Barr Harbor Drive, West Conshohocken, PA 19428.

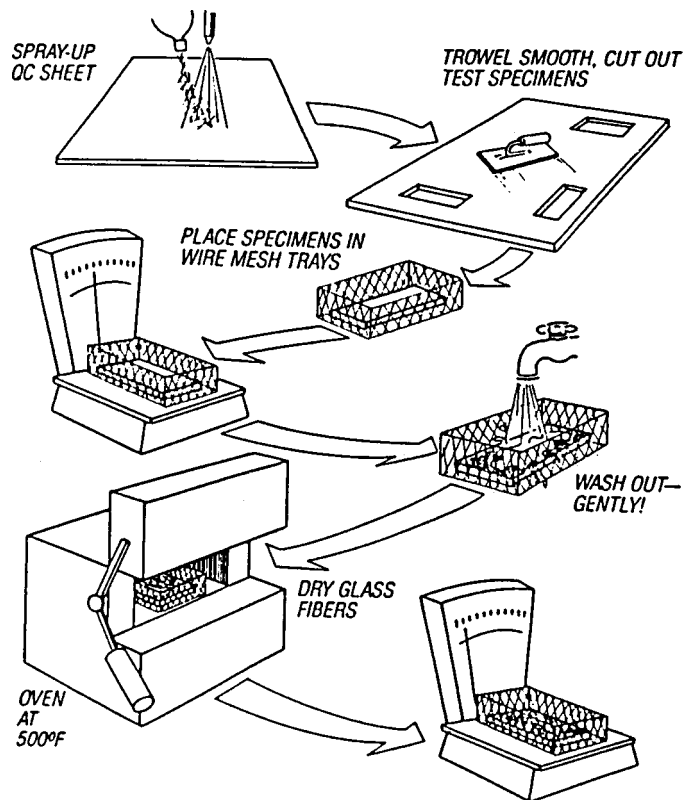

FIG. 2 Procedure for Determination of Glass Fiber Content

10.2 Bias—Since there is no accepted reference material, the bias of this test method cannot be determined.

11. Keywords

11.1 glass fiber; glass fiber reinforced concrete (GFRC); wash-out test