



Standard Test Method for Performing Tension Tests on Glass-Fiber Reinforced Concrete (GFRC) Bonding Pads¹

This standard is issued under the fixed designation C 1230; the number immediately following the designation indicates the year of original adoption or, in the case of revision, the year of last revision. A number in parentheses indicates the year of last reapproval. A superscript epsilon (ϵ) indicates an editorial change since the last revision or reapproval.

1. Scope

1.1 This test method covers determination of the tensile load capacity of glass-fiber reinforced concrete (GFRC) bonding pads used for attaching steel anchors to GFRC architectural panels.

1.2 *This standard does not purport to address all of the safety concerns, if any, associated with its use. It is the responsibility of the user of this standard to establish appropriate safety and health practices and determine the applicability of regulatory limitations prior to use.*

1.3 The values stated in inch-pound units are to be regarded as the standard. The values given in parentheses are provided for information only.

2. Referenced Documents

2.1 ASTM Standards:

D 76 Specification for Tensile Testing Machines for Textiles²

E 4 Practices for Force Verification of Testing Machines³

3. Significance and Use

3.1 Tensile loads determined by this test method are useful for quality control of GFRC architectural panels manufactured using the steel panel frame support design. In addition, test results may be used to verify compliance with governing specifications, research and development, and generating data for use in product design.

4. Apparatus

4.1 *Testing Machine*, a properly calibrated testing machine that can be operated at constant rates of crosshead motion and in which the error in the force measuring system shall not exceed $\pm 1.0\%$ of the maximum force expected to be measured. Equip the testing machine with a deflection measuring and recording device. The stiffness of the testing machine shall be such that the total elastic deformation of the system does not exceed 1.0% of the total deflection of the test specimen during

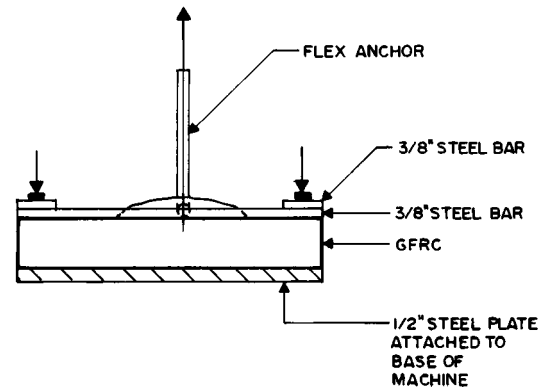
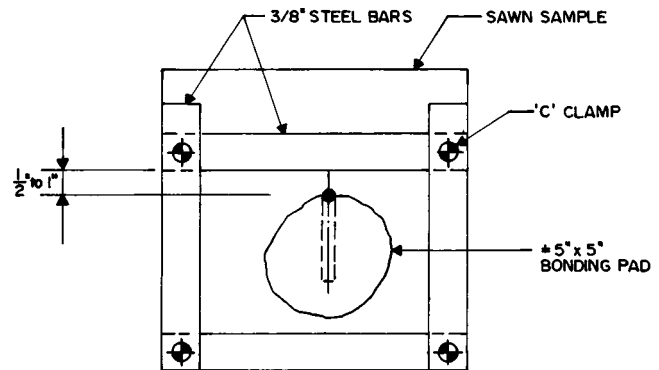

NOTE 1—Manufacture test specimens to keep flex anchor legs as vertical as possible. Support the legs if necessary during curing of the matrix.

FIG. 1 Tension Test Fixture

the test, or appropriate corrections shall be made. The force-indicating mechanism shall be essentially free of inertial lag at the crosshead rate used. The accuracy of the testing machine shall be verified in accordance with Practices E 4 and Specification D 76.

4.2 *Loading Fixture*—The load fixture for applying tensile load is shown schematically in Fig. 1. It consists of a 1/2 in. (13-mm) thick steel base plate. A suitable mechanism for test fixtures is shown in Fig. 2 and Fig. 3. The design of the loading fixture shall be such that the specimen is rigidly attached to the base support. In particular, the section of the specimen adjacent to the flex anchor shall not be allowed to bend while the anchor is being pulled in tension, in order to avoid force eccentricity.

¹ This test method is under the jurisdiction of ASTM Committee C-27 on Precast Concrete Products and is the direct responsibility of Subcommittee C27.40 on Glass-Fiber Reinforced Concrete Made by the Spray-Up Process.

Current edition approved Nov. 10, 1996. Published December 1996. Originally published as C1230 – 93. Last previous edition C1230 – 94.

² Annual Book of ASTM Standards, Vol 07.01.

³ Annual Book of ASTM Standards, Vol 03.01.

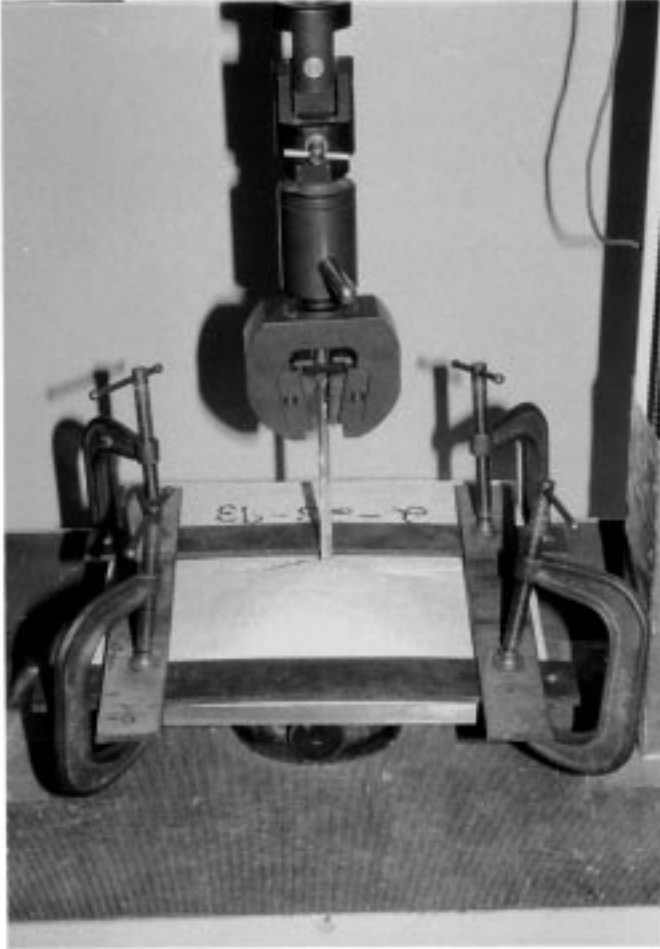

FIG. 2 Suitable Test Fixture

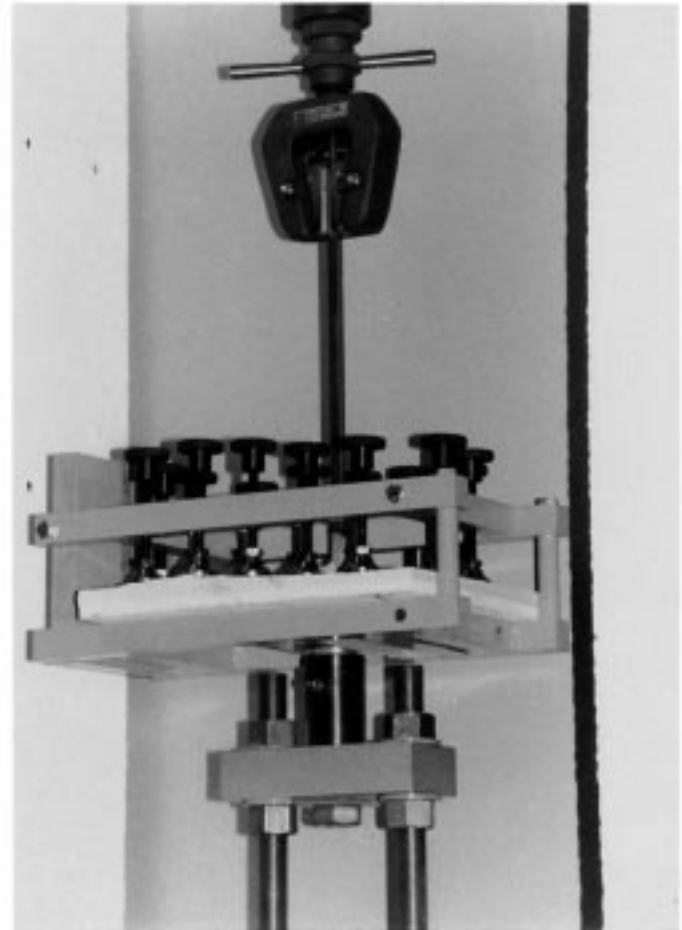

FIG. 3 Suitable Test Fixture

4.3 *Gripping Device*, a suitable mechanical gripping device or jaws to grip the steel anchor. Use a universal joint between the grip and crosshead of the testing machine to ensure the application of a tensile load for the duration of the test.

5. Sampling

5.1 The sampling method shall be in accordance with governing specifications.

6. Test Specimen

6.1 Saw the test specimens from a test board panel prepared at the same time and in a manner identical to production panels. Saw the test specimens so they are nominally 12 in. square, the anchor is in the center, and the specimen edges are a sufficient distance from the bonding pad to allow support during loading. Fig. 4 shows the test specimen.

7. Conditioning

7.1 Condition specimens under the same conditions as production panels prior to test.

8. Procedure

8.1 Align the specimen in the center of the base plate or base support.

8.2 Rigidly clamp the specimen to the base plate.

8.3 Grip the anchor and apply tensile loads to the anchor at a pull-off displacement rate of 0.2 in. (5 mm)/min until failure.

8.4 Failure is defined as the maximum load, or when there is visible distress to the GFRC bonding pad. For small diameter anchors ($\frac{3}{16}$ in. (5 mm) or less) or for certain bonding pad geometries, local failure of the glass-fiber reinforced concrete has been observed at the anchor heel, even though the anchor continues to take additional load. In these instances there is a measurable drop in load, observed on the load deflection graph.

8.5 Record the maximum force and corresponding displacement attained prior to failure of the bonding pad.

8.6 Measure the dimensions of the bonding pad at two locations 90° to each other, accurate to the nearest 0.1 in. (2.5 mm).

8.7 Measure the average thickness of bonding pad over the anchor when wet with pin gauge or when dry with caliper.

9. Report

9.1 Report the following information:

- 9.1.1 Specimen identification number,
- 9.1.2 Age of specimen (if artificially aged, include description of process with time, temperature, etc.),
- 9.1.3 Specimen dimensions,
- 9.1.4 Anchor size,

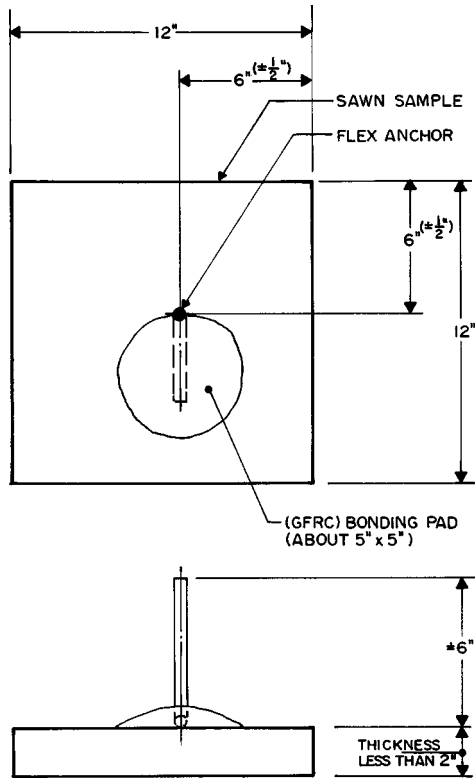

FIG. 4 Test Specimen

- 9.1.7 Displacement at maximum load, inches, and
- 9.1.8 Mode of failure.

10. Precision and Bias

10.1 *Precision*—The precision of the procedure in Test Method C 1230 for measuring the tensile load capacity of GFRC bonding pads is being determined.

10.2 *Bias*—Since there is no accepted reference material suitable for determining the bias for the procedure in Test Method C 1230 for measuring the tensile load capacity, bias has not been determined.

11. Keywords

- 11.1 anchor; bonding pads; bonding strength; tensile load

- 9.1.5 Bonding pad dimensions including thickness over the top of the anchor,
- 9.1.6 Maximum applied force, pounds-force (or Newtons),

The American Society for Testing and Materials takes no position respecting the validity of any patent rights asserted in connection with any item mentioned in this standard. Users of this standard are expressly advised that determination of the validity of any such patent rights, and the risk of infringement of such rights, are entirely their own responsibility.

This standard is subject to revision at any time by the responsible technical committee and must be reviewed every five years and if not revised, either reapproved or withdrawn. Your comments are invited either for revision of this standard or for additional standards and should be addressed to ASTM Headquarters. Your comments will receive careful consideration at a meeting of the responsible technical committee, which you may attend. If you feel that your comments have not received a fair hearing you should make your views known to the ASTM Committee on Standards, 100 Barr Harbor Drive, West Conshohocken, PA 19428.