



Designation: C 1283 – 03

Standard Practice for Installing Clay Flue Lining¹

This standard is issued under the fixed designation C 1283; the number immediately following the designation indicates the year of original adoption or, in the case of revision, the year of last revision. A number in parentheses indicates the year of last reapproval. A superscript epsilon (ϵ) indicates an editorial change since the last revision or reapproval.

1. Scope

1.1 This practice covers the minimum requirements for installing clay flue lining for residential concrete or masonry chimneys.

1.2 The values stated in inch-pound units are to be regarded as the standard. The values stated in parentheses are for informational purposes only.

1.3 *This standard does not purport to address all of the safety concerns, if any, associated with its use. It is the responsibility of the user of this standard to establish appropriate safety and health practices and determine the applicability of regulatory limitations prior to use.*

2. Referenced Documents

2.1 ASTM Standards:

- C 24 Test Method for Pyrometric Cone Equivalent (PCE) of Fireclay and High Alumina Refractory Materials²
- C 27 Classification of Fireclay and High-Alumina Refractory Brick²
- C 55 Specification for Concrete Brick³
- C 90 Specification for Loadbearing Concrete Masonry Units³
- C 99 Test Method for Modulus of Rupture of Dimension Stone⁴
- C 129 Specification for Nonloadbearing Concrete Masonry Units³
- C 170 Test Method for Compressive Strength of Dimension Stone⁴
- C 199 Test Method for Pier Test for Refractory Mortars²
- C 216 Specification for Facing Brick (Solid Masonry Units Made from Clay or Shale)³
- C 270 Specification for Mortar for Unit Masonry³
- C 315 Specification for Clay Flue Linings³
- C 652 Specification for Hollow Brick (Hollow Masonry Units Made from Clay or Shale)³

¹ This practice is under the jurisdiction of ASTM Committee C04 on Vitrified Clay Pipe and is the direct responsibility of Subcommittee C04.20 on Methods of Test and Specifications.

Current edition approved February 10, 2003. Published June 2003. Originally approved in 1994. Last previous edition approved in 2002 as C 1283-02.

² *Annual Book of ASTM Standards*, Vol 15.01.

³ *Annual Book of ASTM Standards*, Vol 04.05.

⁴ *Annual Book of ASTM Standards*, Vol 04.07.

C 896 Terminology Relating to Clay Products³

C 1184 Specification for Structural Silicone Sealants⁴

3. Terminology

3.1 *General*—Terminology C 896 should be used for clarification of definitions in this practice.

3.2 Definitions of Terms Specific to This Standard:

3.2.1 *chimney connector*—tubular unit or pipe used to convey products of combustion from a heating or cooking appliance to the chimney.

3.2.2 *flue*—passageway within a chimney through which products of combustion are conveyed.

3.2.3 *flue liner*—manufactured tubular nonloadbearing fired clay unit, normally used for conveying hot gases in chimneys.

3.2.4 *masonry chimney*—vertical structure constructed of brick, concrete, concrete masonry units, or stone, which contains one or more flues, and conveys products of combustion from a heat source or cooking appliance.

3.2.5 *smoke chamber*—section of a fireplace above the throat and below the flue, which is an area of transition from the shape of the throat to the shape of the flue.

3.2.6 *thimble*—manufactured tubular nonloadbearing fired clay unit normally used to connect the chimney connector from an appliance through the wall of the chimney to the flue.

4. Footings and Foundations

4.1 Footings for masonry chimneys shall be constructed of concrete or solid masonry at least 12 in. (305 mm) thick, and it shall extend at least 6 in. (153 mm) beyond the face of the foundation or support wall on all sides. Footings shall be founded below frost depth on natural undisturbed earth or engineered fill. In areas not subjected to freezing, footings shall be founded at least 12 in. (305 mm) below finished grade.

4.2 The foundation shall be placed, with respect to adjacent structures existing or anticipated, to minimize the possibility of damage by construction operations or by transmission of additional loads to the supporting soils.

4.3 Concrete footings and foundations shall conform to local building codes.

4.3.1 In the absence of a local building code, concrete with a minimum 28 day compressive strength of 3000 psi (21 mPa) shall be used.

4.4 Where a chimney or fireplace is added to the outside of the exterior wall of an existing structure, the following shall apply:

4.4.1 The new footing shall be installed at the same level or below the existing footing, provided the level is below the frost line and the new footing is placed on soil with adequate bearing capability.

4.4.2 The existing drainage provision shall not be obstructed.

5. Chimney Construction

5.1 Materials:

5.1.1 *Flue Linings*— Specification C 315.

5.1.2 *Refractory Mortar*—Test Method C 24 (cone 10) and Test Method C 199 (medium duty).

5.1.3 *Concrete Block*— Specification C 90 or Specification C 129.

5.1.4 *Brick*—Specification C 55 or Specification C 216, Grade SW.

5.1.5 *Mortar*—Specification C 270.

5.1.6 *Firebrick*—Classification C 27.

5.1.7 *Natural Stone*— Test Method C 170 or Test Method C 99.

5.2 The chimney consists of a flue liner and the chimney wall. When used to vent a fireplace, the chimney is constructed directly on the smoke chamber.

5.3 The flue lining shall start from a point not less than 8 in. (205 mm) below the entrance of the lowest chimney connector.

5.4 Flue liners shall be installed, each flue liner carefully bedded on the previous one, using refractory mortar. All joints of flue liners shall be $\frac{1}{16}$ in. (1.5 mm) to $\frac{1}{8}$ in. (3 mm) thick, and struck flush so as to produce a straight, smooth, fully aligned flue. Liners shall be placed in such a manner as to minimize ledges or steps within the flue passageway.

5.5 Flue liners shall be surrounded by masonry on all sides but shall not be bonded to the surrounding masonry. The flue liner shall contact the chimney wall only as necessary for support and alignment in order to permit the flue liner to expand and contract freely. The separation of the flue liner from the surrounding concrete or masonry shall not exceed the wall thickness of the flue liner. Where seismic reinforcing requires the space between the flue liner and the chimney wall to be grouted solid, the flue shall be wrapped with ceramic fiber paper capable of withstanding temperatures of 2100°F to prevent the flue liner from bonding to the chimney walls.

5.6 The flue lining shall extend the entire height of the chimney. The lining shall be carried up as vertically as possible. When offsets are necessary, their slopes shall be no flatter than 30° from vertical.

5.7 When more than one flue is contained in a chimney, a separation shall be provided between adjacent flues. The separation shall be solid masonry wythes (partitions) not less than 4 in. (102 mm) nominal thickness and bonded into the chimney walls.

5.8 Adjustments to the liner size or shape shall be made with a masonry saw.

5.8.1 When fabricating custom size flue liners, the aspect ratio shall not exceed 2:1 and the vertical joint shall be sealed with refractory mortar as required in 5.4.

5.9 Openings in the flue liner for chimney connectors shall be manufactured or machine cut.

5.10 Chimney walls shall be constructed of concrete or solid masonry units at least 4 in. (102 mm) nominal thickness.

5.10.1 Products for chimney wall masonry construction are those (concrete, concrete masonry units, brick or stone) that are at least 75 % solid or grouted solid and which meet the requirements of Specification C 55, Specification C 90, Specification C 216 Grade SW, or Specification C 652.

5.10.2 Cast in place concrete chimneys must be designed by an engineer.

5.11 The chimney shall be adequately anchored to the building to provide stability against wind and seismic loads. In seismic design categories, building codes may require additional anchoring or reinforcements.

5.12 The mortar in all joints exposed to weather shall be compacted and well tooled.

5.13 Masonry chimneys shall extend 3 ft (915 mm) above the highest point of the structure where chimneys pass through a roof of a building and at least 2 ft (610 mm) above any location of any structure within 10 ft (3 m) (measured horizontally from the vertical centerline chimney line).

6. Clearances

6.1 The minimum air space clearance between interior masonry chimneys and combustible materials shall be 2 in. (51 mm). Any chimney with at least one interior wall shall be treated as interior.

6.2 The minimum air space clearance between exterior masonry chimneys and combustible materials shall be 1 in. (25 mm).

6.3 Combustible material shall be permitted to abut the masonry chimney sidewalls, provided they are a minimum of 12 in. (305 mm) from the inside surface of the flue liner.

6.4 All spaces between chimneys and floors or ceilings through which chimneys pass shall be fire stopped with noncombustible material. The fire stopping of spaces between chimneys and wood joists, beams, or headers shall be galvanized steel not thinner than 26 gage or noncombustible sheet material not thicker than $\frac{1}{2}$ in. (13 mm).

7. Openings For Chimney Connections

7.1 The chimney connection shall be made by either a metal or clay thimble. The thimble shall be installed on a $\frac{1}{4}$ in. (6 mm) per foot slope toward the appliance. This is to allow any liquid creosote to drain back into the appliance for reburning.

7.2 A minimum of 12 in. (305 mm) of solid masonry, or a combination of 4 in. (102 mm) solid masonry and 2 in. (51 mm) air space shall be provided between clay thimbles and combustible materials.

7.3 The thimble shall pass through the flue lining and be flush with the inside of the flue lining or butted to the outside of the flue liner. The joint between the thimble and the flue lining shall be sealed with a refractory mortar.

7.4 The opening for a flue pipe connection shall be positioned to maintain the clearances from combustible construction, as specified in Section 6.

7.5 The stovepipe shall be positioned so that horizontal movement will not cause it to back out of the thimble or protrude into the flue.

8. Chimney Caps

8.1 All masonry chimneys shall have a chimney cap that slopes a minimum of 10° downward from the flue liner to the edge of the chimney cap (see Fig. 1).

8.2 Chimney caps shall overhang the chimney wall by a minimum of 2 in. (51 mm).

8.3 Chimney caps are of the following types and construction:

8.3.1 Precast or cast-in-place concrete caps shall be a minimum of 2 in. (51 mm) in thickness, shall have a drip slot on the underside at least 1 ½ in. (38 mm) away from the chimney wall, and shall be reinforced with a minimum of ½ in. (13 mm) mesh galvanized hardware cloth located halfway into the filled form.

8.3.2 Metal chimney caps must lap down the chimney wall at least 4 in. (102 mm) and a noncombustible resilient sealant shall be used between the metal cap and the flue liner and between the base of the metal cap and the chimney.

8.3.3 Stone caps shall be a minimum of 2 in. (51 mm) in thickness and shall have a drip slot on the underside at least 1 ½ in. (38 mm) away from the chimney wall.

8.4 Chimney caps shall be separated from the flue lining by a bond break, and this separation shall be sealed with a noncombustible resilient sealant to prevent water entering the chimney. This is a maintenance joint and should be checked and renewed as needed (see Fig. 1).

8.5 Clay flue linings shall extend above the chimney cap by not more than 4 in. (102 mm).

9. Special Conditions

9.1 Special features to mitigate any problem relating to condensation shall be permitted in the construction of chimneys.

9.1.1 Flue liners with joints that prevent leakage of condensation shall be permitted. Socketed and overlapping joints manufactured as an integral part of the flue liner are acceptable.

9.1.2 A condensate drain installed at the base of the chimney shall be permitted.

10. Keywords

10.1 chimney; chimney caps; clay; fireplace; flue lining; masonry; stove pipe; venting

ASTM International takes no position respecting the validity of any patent rights asserted in connection with any item mentioned in this standard. Users of this standard are expressly advised that determination of the validity of any such patent rights, and the risk of infringement of such rights, are entirely their own responsibility.

This standard is subject to revision at any time by the responsible technical committee and must be reviewed every five years and if not revised, either reapproved or withdrawn. Your comments are invited either for revision of this standard or for additional standards and should be addressed to ASTM International Headquarters. Your comments will receive careful consideration at a meeting of the responsible technical committee, which you may attend. If you feel that your comments have not received a fair hearing you should make your views known to the ASTM Committee on Standards, at the address shown below.

This standard is copyrighted by ASTM International, 100 Barr Harbor Drive, PO Box C700, West Conshohocken, PA 19428-2959, United States. Individual reprints (single or multiple copies) of this standard may be obtained by contacting ASTM at the above address or at 610-832-9585 (phone), 610-832-9555 (fax), or service@astm.org (e-mail); or through the ASTM website (www.astm.org).

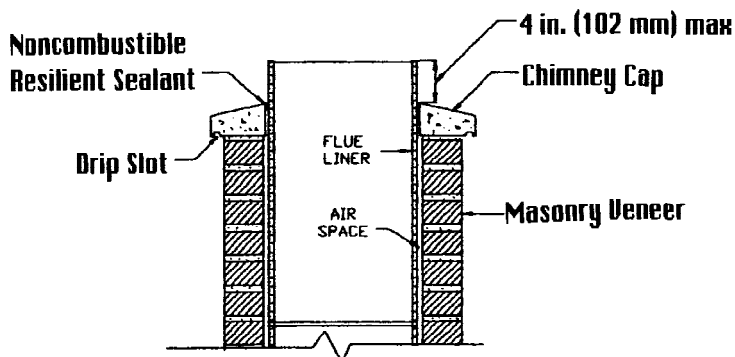

FIG. 1 Chimney Cap