



Standard Guide for Design and Construction of Brick Liners for Industrial Chimneys¹

This standard is issued under the fixed designation C 1298; the number immediately following the designation indicates the year of original adoption or, in the case of revision, the year of last revision. A number in parentheses indicates the year of last reapproval. A superscript epsilon (ϵ) indicates an editorial change since the last revision or reapproval.

1. Scope

1.1 This guide covers procedures for the design, construction, and serviceability of brick liners for industrial chimneys. The structural design criteria are applicable to vertical masonry cantilever structures supported only at their base, either by a foundation, a concrete pedestal, or by some means from the outer concrete shell. Excluded from direct consideration are single-wythe, sectional brick linings that are supported on a series of corbels cast in the outer chimney shell.

1.2 The values stated in inch-pound units are to be regarded as the standard. The values given in parentheses are for information only.

1.3 *This standard does not purport to address all of the safety concerns, if any, associated with its use. It is the responsibility of the user of this standard to establish appropriate safety and health practices and determine the applicability of regulatory limitations prior to use.*

2. Referenced Documents

2.1 ASTM Standards:

- C 395 Specification for Chemical-Resistant Resin Mortars²
- C 466 Specification for Chemically Setting Silicate and Silica Chemical-Resistant Mortars²
- C 980 Specification for Industrial Chimney Lining Brick²
- E 447 Test Methods for Compressive Strength of Masonry Prisms²
- E 111 Test Method for Young's Modulus, Tangent Modulus, and Chord Modulus³

2.2 ACI Standard:

- 307–88 Practice for the Design and Construction of Cast-In-Place Reinforced Concrete Chimneys⁴

2.3 ASCE Standard:

- ASCE 7-88 Minimum Design Loads for Buildings and Other Structures (Formerly ANSI A58.1)

2.4 Other Standard:

- 1991 Uniform Building Code, International Conference of

¹ This guide is under the jurisdiction of ASTM Committee C-15 on Manufactured Masonry Units and is the direct responsibility of Subcommittee C15.09 on Chemical-Resistant Units.

Current edition approved June 15, 1995. Published August 1995.

² Annual Book of ASTM Standards, Vol 04.05.

³ Annual Book of ASTM Standards, Vol 03.01.

⁴ Available from American Concrete Institute, P.O. Box 19150, Detroit, MI 48219.

Building Code Officials, California⁵

3. Terminology

3.1 Notations:

a	= brick dimension in radial direction (in.)
b	= brick dimension in tangential direction (in.)
c	= brick chamfer (in.)
C_e	= chimney deflection due to earthquake loads (in.)
d	= outside diameter of brick liner (in.)
D	= mean liner diameter at a given elevation (in.)
E_m	= masonry modulus of elasticity as established by performing brick prism test or by past experience, psi
f_b	= critical liner buckling stress, psi
f_d	= maximum vertical compressive stress due to dead load, psi
f_{de}	= maximum vertical compressive stress due to the combined effect of earthquake and dead load, psi
f_{dw}	= maximum vertical compressive stress due to the combined effect of wind and dead load, psi
f_m	= average ultimate masonry compressive strength established by performing brick prism test or by past experience, psi
f_v	= maximum shear stress due to wind or earthquake, psi
$F.S.$	= factor of safety
h	= total liner height (ft)
h_e	= height of liner above elevation being checked for buckling (ft)
L_e	= liner deflection due to earthquake loads (in.)
P	= constructional out-of-plumbness of liner with respect to shell (in.)
r	= average mean radius of liner (ft)
S	= shell deflection due to sun effect (in.)
T	= liner deflection due to differential temperature effects (in.)
t	= wall thickness (in.)
v	= coefficient of variation in brick prism tests
W	= shell deflection due to design wind loads (in.)
α	= coefficient of thermal expansion for brick liner (use 3.5×10^{-6} unless otherwise established) (in./in./°F)

4. Significance and Use

4.1 History:

4.1.1 For many years, brick liners have been used with an excellent record of performance. For the most part, however, the design and construction of brick liners has been based on past industry practice due to the lack of available information and knowledge of the physical properties of the brick and mortar, the thermal and seismic behavior of brick liners, and many related characteristics that were not properly or accurately defined.

4.1.2 The use of scrubbers, which lower gas temperatures and introduce highly corrosive condensates into the flue gas system, requires many new design considerations. The effect

⁵ Available from International Conference of Building Officials, 5360 South Workman Mill Road, Whittier, CA 90601.

that scrubbers have on brick liners is an ongoing area of study, since a number of liners have experienced growth- and deflection-related problems which may be attributable, at least in part, to nonuniform temperature and moisture conditions within the liners.

4.2 *Purpose*—The recommendations contained herein represent current industry practices and serve to define the pertinent considerations that should be followed in the design and construction of brick chimney liners.

5. Materials

5.1 *General*—The selection of suitable liner materials, those capable of resisting the environment to which they will be exposed, should be based on an evaluation of the unique operating conditions that exist in each application. Although it is not the intent to restrict the applicability of this guide, and while other materials may be appropriate in some applications, the chemical-resistant brick and mortar standards set forth in 5.2 and 5.3 define the type of materials used in the majority of brick liners that are specified, designed, and erected today. All portions of this guide reflect test data, design requirements, and other practices as they relate to these materials. The provisions of this guide should be carefully reviewed for applicability if other materials are specified or used. Due to a greater knowledge of overall plant operation, material capabilities, and the flue gas environment, the owner's technical representative should be responsible for selecting all liner materials.

5.2 Brick:

5.2.1 Unless the specific application precludes their use, brick conforming to the requirements of Specification C 980 should be used. Specification C 980 covers solid kiln-fired brick made of clay, shale, or mixtures thereof.

5.2.2 Three types of brick are defined in Specification C 980: Types I, II, and III. By definition, the brick types vary, respectively, in decreasing degrees of absorption and acid solubility. These bricks generally are resistant to all acids and alkalis (with the exception of acid fluorides and strong, hot caustics). Types I, II, and III brick safely will withstand continuous temperatures up to 750°F. Generally, the bricks will withstand short-term exposure to temperatures in excess of 750°F, but the capability of the bricks to resist higher temperatures should be studied case by case. The selection of the brick type and the potential need for testing beyond the requirements of Specification C 980 should be determined on an individual project basis.

5.2.3 Specification C 980 brick Types I and II generally are available from any manufacturer who makes double-sized, kiln-fired, solid brick for corrosion-resistant applications. The stringent requirements for Type III brick, however, make it more difficult and expensive to manufacture. Consequently, availability of Type III brick is limited; therefore, before specifying Type III brick, determine both the necessity of its use and its availability.

5.3 Mortar:

5.3.1 Unless specific application requirements dictate otherwise, mortar should conform to the requirements of one of the brick types listed herein.

5.3.1.1 *Specification C 466*—These widely-used mortars exhibit excellent resistance to most acids (except hydrofluoric

acid), water, solvents, and temperatures to 1200°F. These mortars are also resistant to intermittent exposure to mild alkalis, but their primary capability is resisting the strong acids commonly found in fossil-fuel flue gas environments.

5.3.1.2 *Specification C 395*—Organic resin-type mortars (such as Furan mortar) have been used in brick chimney liners, mainly due to their capacity to resist a wider variety of chemicals than inorganic mortars. Generally suitable for use over a wider pH range, they resist non-oxidizing acids, alkalis, salts, water, and temperatures to 350°F.

5.3.1.3 High alumina cement (HAC) mortars, while not generally used in brick chimney linings, also are available. They are usually used in conjunction with heat-resistive aggregates and may be suitable for some chimney applications.

5.3.2 It is important to recognize that the selection of the proper mortar is essential to successful functioning of a brick liner. The various types of chemical-resistant mortars should be evaluated to determine which is the most suitable for a given application and set of operating conditions.

5.4 *Appurtenances*—Due to the availability of a wide variety of metallic materials and the great variations in the flue gas conditions to which materials are exposed, it is beyond the scope of this document to make recommendations regarding the suitability of materials for liner appurtenances such as breeching ducts, bands, lintels, buckstays, hoods, caps, and doors. The selection of these materials can be made only by evaluating the specific factors and conditions that exist on each individual project. One must evaluate the operating environment, projected maintenance requirements, and other such technical and economic evaluation factors commonly associated with the process of material selection.

5.5 *Field Testing*—If it is determined that field testing is required for a particular project, the test methods and acceptance criteria should be agreed upon mutually by the material manufacturers, the contractor, and the owner's technical representative. Certification that the materials shipped for use on the project conform to the requirements of their respective ASTM specifications should be obtained from the manufacturer.

6. Construction Requirements

6.1 Handling and Storage of Materials:

6.1.1 Brick pallets and the individual brick units should be handled as little as possible to reduce the likelihood of cracking and chipping. While it is obviously beneficial to keep the amount of chipping and cracking to a minimum, no criteria currently exist to evaluate what constitutes acceptability. Therefore, if deemed necessary, the specifier should include acceptance criteria in the project specification. Cracking is not always evident, and pallets suspected of containing cracked brick should be checked closely by removing individual samples. Badly damaged or cracked brick should not be used.

6.1.2 Mortar and brick should be kept dry and free from frost during construction. Heated storage sheds should be used when the ambient temperature during construction is below 40°F (4°C) unless otherwise recommended by the manufacturers of the brick or mortar.

6.2 Brick Sizing:

6.2.1 It is standard industry practice to use chamfered brick

to approximate the circular liner shape. The proper chamfer-to-diameter relationship is shown in Fig. 1. In certain cases, it may be necessary to use two or more chamfers for a liner with a larger change in diameter over its height. The proper chamfer will keep mortar joint size variation to a minimum, resulting in tight, acid-resistant vertical seams.

6.2.2 Double-sized brick, typically 3¾ by 4½ by 8 in., is used in brick liner construction, although any other brick size that meets the recommendations of this guide is acceptable.

6.3 *Brick Bonding:*

6.3.1 The use of proper brick bonding techniques inhibits delamination, resulting in stronger, more crack-resistant walls. A proper brick bond will limit the propagation of cracks.

6.3.2 To minimize the effects of tolerance differences between “stretchers” (brick laid in the circumferential direction) and “headers” (brick laid in the radial direction), it is beneficial to reverse the brick bond frequently. As a minimum requirement, the brick bond for all wall thicknesses should be reversed, or staggered, after every three courses.

6.3.3 Circumferentially, brick should be staggered from course to course to prevent the stacking of vertical joints. Since brick liners are commonly tapered, occasional vertical alignment of radial joint will inevitably occur and is considered acceptable practice.

6.4 *Mortar Usage:*

6.4.1 Mortar should be stored and used in accordance with the manufacturer’s recommendations. Mortar manufacturers generally make representatives available to assist field personnel during initial mixing and material handling operations.

6.4.2 Chemically-setting mortars typically used in brick liners are sensitive to changes in temperature and humidity, and small variations in mix proportions. The builder should monitor the mortar consistency during the course of construction. Any changes in the visual appearance of the mortar, or changes in handling, mixing, and setting characteristics immediately should be brought to the attention of the manufacturer.

6.4.3 The working time for a chemically-setting mortar is short compared to that for a portland cement mortar. Only mortar quantities that can be used within their working time should be mixed, since retempering of these mortars is not

recommended by the manufacturers.

6.4.4 All brick in the masonry chimney lining should be laid with full-bed, circumferential, and radial mortar joints. Mortar shall be applied to the brick by the use of a trowel. All mortar joints on the interior surface of the liner shall be trowel-struck.

6.5 *Rate of Construction*—A typical liner is constructed from a multiple-point suspension scaffold, which facilitates a fast rate of construction, even to the point of making it possible to build greater heights of freshly laid masonry than is warranted by the setting rate of the mortar. This is particularly true when constructing small diameter liners when the ambient temperature is low. Building at a rate faster than is warranted by the setting characteristics of the mortar can result in premature cracking and deformation of the lining. The rate of brick laying and the mortar set time should be monitored so that partially set masonry is not damaged and tolerances are maintained.

6.6 *Banding:*

6.6.1 For optimum performance, the bands should be installed snugly around the liner, recognizing that some circumferential expansion will occur under thermal loading. The bands should be positioned either by the use of vertical supports or by placing the band on offset brick. The brick should then be laid directly against the pre-positioned band. Applied alone, this method of band installation should yield adequate contact between the brick and the band around the full circumference. Provided such a method and good construction practices are employed, the filling of any remaining gaps between the brick and band may not be necessary.

6.6.2 In the event that post-tensioned band connections are used, the bolts should not be tightened until the mortar has set up sufficiently that it will not deform under tightening.

6.7 *Tolerances:*

6.7.1 The brick liner should be constructed within the following tolerances:

6.7.1.1 *Vertical Alignment*—The center point of the liner should not vary from its vertical axis by more than 0.10 % of its height or 1 in., whichever is greater, at any point during construction. Locally, the center point of the liner should not vary by more than 1 in. in 10 ft.

6.7.1.2 *Diameter*—The measured diameter at any elevation should not vary from the theoretical diameter by more than 2 %.

6.7.1.3 *Local Deviations*—The measured radius from the center point of the liner at any elevation should not vary by more than 2 %.

6.7.1.4 *Interior Surface*—The maximum projection or offset between bricks on the interior surface of the liner should not exceed ⅛ in.

6.7.1.5 *Mortar Joints*—All joints should be laid with ⅛ in. minimum thickness. Mortar joint width depends on the actual brick dimensions, brick chamfer, brick warpage, bonding construction, and the characteristics of the mortar being used in the liner construction. Quality workmanship and industry practice should maintain mortar joint widths not greater than ¼ in.

7. *Design of Brick Liners*

7.1 This section recommends the criteria to be used in the

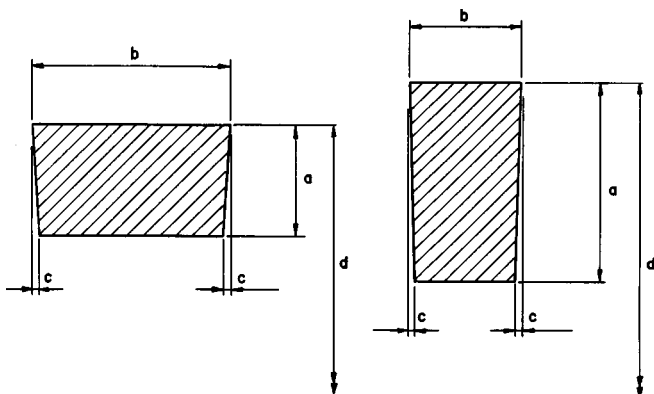

$C = \text{chamfer (each side)} = \frac{ab}{d}$ (to nearest ⅛ in.), in.

- a = brick dimension (radial direction), in.
- b = brick dimension (tangential direction), in.
- d = outside diameter brick liner, in.

FIG. 1 Brick Chamfers

design of circular brick chimney liners. Included are the procedures to be used in determining masonry strength and calculating loads and stresses in the liner. This section also provides guidelines for establishing limits on liner geometry for special design considerations through openings and for proper annular clearances.

7.2 General Design Considerations:

7.2.1 Brick liners should be designed to resist stresses resulting from the weight of the liner (including attachments), from earthquake, and from wind on projecting areas of the liner.

7.2.2 The stress should be computed and combined in accordance with the methods described herein and should not exceed the allowable stresses specified in 7.6.

7.2.3 The following limitations on liner geometry are recommended:

7.2.3.1 The minimum wall thickness should be 8 in.

7.2.3.2 The height of any segment of liner wall of a given thickness should not exceed 250 ft.

7.2.3.3 The mean liner diameter-to-wall thickness ratio (D/t) at any elevation should not exceed 60.

7.2.3.4 The minimum thickness of the wall at the breaching opening location should be 12 in.

7.2.3.5 Wall thickness changes should be made on the exterior surface of the liner.

7.2.3.6 An opening width should not exceed one-half the internal diameter of the liner at the opening elevation. The liner taper may be governed by this requirement.

7.2.3.7 In the case of multiple openings in a given cross section, the cumulative width of the openings should not exceed one-half the inner liner circumference at that elevation.

7.2.3.8 The openings defined above should include adequate clearance for breaching stiffeners, packing seals, or other pertinent details. Internal bracing, if permitted by specification, may be utilized to reduce the size of external stiffeners.

7.3 Determination of Masonry Strength—Brick masonry strength (f_m) should be determined by one of the following methods:

7.3.1 Method No. 1—Standard Practice:

7.3.1.1 Sufficient testing on materials typically used in brick liners has been performed to establish masonry strength (f_m) safely in the instances when these materials are used. The f_m for brick that conforms to the minimum requirements of Specification C 980 and mortar that conforms to the minimum requirements of Specification C 466 may be taken equal to 5300 psi.

7.3.2 Method No. 2—Brick Prism Tests:

7.3.2.1 By direct testing in a laboratory environment, determine the average 28-day compressive strength of the brick masonry to be used in the design of the brick liner. Perform testing as follows:

7.3.2.2 The prisms should be built with the same materials that are to be used in the construction of the liner. That is, the materials used for testing should meet the same minimum material specification requirements as stipulated by the project specification, and also be made by the same manufacturers who produce the construction materials.

7.3.2.3 All factors and conditions, such as the quality of

workmanship, mortar consistency, and joint thickness, should be the same as used in constructing the liner.

7.3.2.4 A minimum of five prisms should be constructed as shown in Fig. 2.

NOTE 1—Prism size shown was chosen as the standard prism in order to avoid height correction factors.

7.3.2.5 After construction, the prisms should be stored at or above the minimum temperature specified for mortar usage, but not less than 50°F for the duration of the curing period.

7.3.2.6 The prisms should be tested at 28 days in accordance with the relevant provisions of Test Methods E 447.

7.3.2.7 When loading the prisms, strain measurement should also be taken and a stress-versus-strain curve plotted. The compressive modulus of elasticity (E_m) of the masonry shall be determined in accordance with the provisions of Test Method E 111, using the initial tangent method and the resulting value utilized in the final design calculations for the liner.

7.3.2.8 If the coefficient of variation (v) of the prisms tested exceeds 10 %, multiply the average compressive strength of the five prisms by the factor shown below to determine f_m .

$$1 - 1.5(0.01v - 0.10) \tag{1}$$

7.4 Seismic Analysis:

7.4.1 General:

7.4.1.1 Brick liners shall be designed and constructed to resist the earthquake effects determined in accordance with the requirements of this section. The project specification should

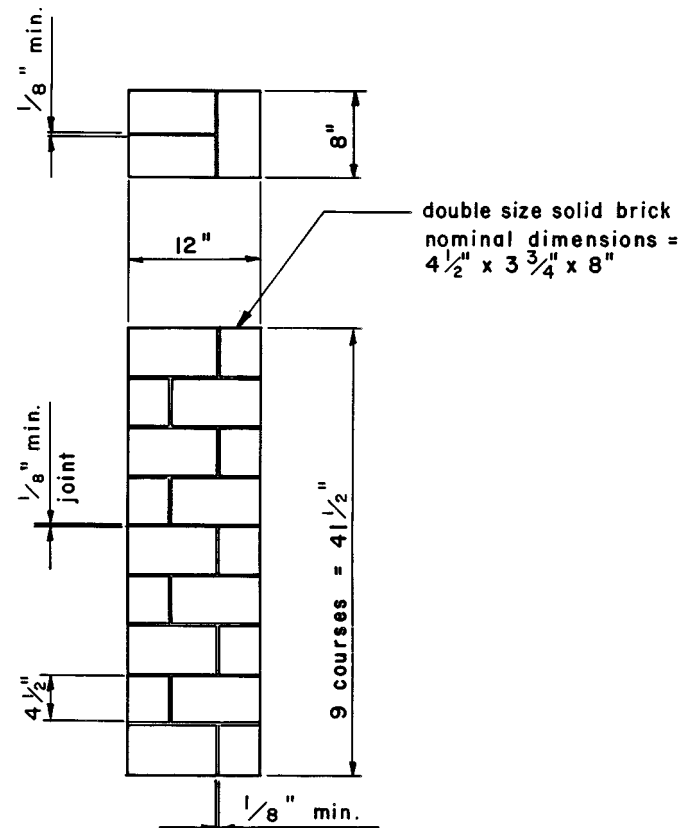

FIG. 2 Standard Prism

state the applicable earthquake zone in accordance with the ASCE 7-88 maps for seismic zones.

7.4.1.2 The seismic analysis of brick chimney liners should be based on either the dynamic response spectrum analysis method or the equivalent static lateral force analysis method. It is expected that the dynamic response method would yield more accurate results.

7.4.1.3 Freestanding brick liners should not be used in areas near major active faults or other strong seismicity areas, specifically Zones 3 and 4 as defined by ASCE 7-88.

7.4.2 *Dynamic Response Spectrum Analysis Method:*

7.4.2.1 The analytical model of the brick chimney liner should accurately represent variations in the brick liner wall thickness and diameter over its height as well as the support condition. A minimum of ten beam elements should be included in the model. When the brick liner is supported on a pedestal or by the outer concrete shell, a dynamic analysis should be used for the design of the brick liner. For the materials defined in Section 5, Modulus of Elasticity (E_m) of the masonry wall shall be established by either brick prism tests in accordance with 7.3.3.7 or should be taken equal to 2 500 000 psi.

7.4.2.2 The analysis should be performed using elastic modal methods. The total dynamic response of the chimney liner in terms of moments, shears, and deflections should be determined using the SRSS (square root of the sum of the squares of modal maxima) summation over a minimum of five normal modes.

7.4.2.3 A site-specific response spectrum may be used when available. The site spectrum should be established based on elastic response with a minimum of 80 % probability of not being exceeded in a 50-year interval. The ground motion represented by the spectra should be based on the geologic, tectonic, seismic recurrence information and foundation material properties associated with the specific site. The spectra should be representative of motions that can be generated by all known faults that can affect the site. The shape bounds of these spectra should be based on mean value or a probability value of 50 %. In lieu of the site-specific response spectra, the design response spectra given in ACI 307 with 5 % damping may be used. The ACI response spectra shape is consistent with that of the Uniform Building Code with Soil Type 1. Vertical seismic excitation need not be considered, and only one horizontal seismic excitation should be included in the response spectrum analysis.

7.4.3 *Equivalent Static Lateral Force Analysis Method*—Provisions for the static analysis of a brick liner under seismic loading should be in accordance with those given in ACI 307. For the material defined in Section 5, the unit weight of brick liner should be taken as 140 pcf, and the Modulus of Elasticity should be established in the same manner as for the Response Spectrum Method.

7.4.4 *Earthquake Reduction Factor*—A brick liner designed to resist seismic moments calculated in accordance with 7.4.2 or 7.4.3 should yield a structure that is relatively free from structural damage after an earthquake of the specified design intensity. However, applying these loads to certain brick liners in Zone 2, and even Zone 1 areas, will result in liner designs

that do not meet the allowable stress and stability criteria recommended elsewhere herein. Since the failure of a brick liner constructed within an outer concrete shell poses virtually no hazard to life or limb, and since such a failure also should not prevent the continued operation of the plant, the use of a Moment Reduction Factor of .75 may be used, provided the risk for potentially extensive damage is understood. Because of the uncertainty surrounding the occurrence of seismic events and the fact that acid-resistant masonry may be the best material to resist the flue gas conditions, historically this risk has been taken. The use of this Moment Reduction Factor is analogous to the lower Use Factor permitted in past editions of ACI 307.

7.5 *Vertical Stresses:*

7.5.1 *Introduction and Method of Analysis:*

7.5.1.1 All brick liners are subject to dead load, wind (if applicable), and earthquake (if applicable).

7.5.1.2 Application of these loads to the liner results in vertical stresses, which can be calculated using conventional, working stress design methods.

7.5.2 *Dead Load Stress:*

7.5.2.1 In addition to the weight of the liner, the dead load should include the estimated weight of all permanent attachments and other loads.

7.5.2.2 Stress calculations should account for any reduction or increase in cross-sectional area due to openings, pilasters, or variations in wall section.

7.5.3 *Earthquake Stress*—Earthquake loadings result in liner-bending stresses, which always act in combination with the dead load. When the applied earthquake moment is sufficiently large to result in tension over part of the section, the design should be performed on the basis of a cracked section analysis with entire tensile area considered ineffective.

7.5.4 *Wind Stress*—Wind loadings should be considered if a significant portion of the liner, such as a projecting portion above the chimney column, is exposed to the wind. The bending stresses resulting from wind moments should be combined with the dead load stresses using the same methods described in 7.5.3.

7.6 *Allowable Stresses*—The resulting stress levels for the load combinations noted above should be within the allowable values given below:

$$f_d \leq 0.075 f_m \quad (2)$$

$$f_{de} \text{ or } f_{dw} \leq 0.15 f_m \quad (3)$$

$$f_v < 0.5 \sqrt{f_m} \quad (4)$$

NOTE 2— $f_m = 5300$ psi for Method No. 1 requirements (see 7.3.2.1).

7.7 *Critical Buckling Stress:*

7.7.1 The critical buckling stress at any elevation of the liner can be calculated by the following equation:

$$f_b = \frac{4E_m \times h_c/h}{(h/r)^2} \quad (5)$$

where:

h_e = height of liner above elevation under consideration, ft,
and

r = average mean radius of the liner, ft.

7.7.2 At any elevation, f_b should be at least 5.0 times greater than the maximum calculated dead load stress and at least 2.5 times greater than the maximum calculated combined dead load and overturning stress. The liner shall be checked at the bottom of each wall thickness, including the base.

7.8 *Liner Stability*—The liner should be investigated for stability against overturning. The minimum factor of safety against overturning shall be 1.30 at any elevation.

7.9 *Thermal Effects*—Thermal differentials through the liner wall result in both vertical and horizontal compressive stresses on the inside face and tensile stresses on the outside face of the brick wall. Since masonry has limited tensile capacity, thermal cracks are frequently observed on the exterior of brick liners. These cracks correspondingly relieve the compressive stresses on the interior liner face; for this reason, thermal stresses need not be considered in the liner design.

7.10 *Opening Design:*

7.10.1 Pilasters should be used at the sides of the openings for opening widths greater than 0.3 ID, openings representing more than 10 % of the full cross-sectional area of the liner, or openings wider than 5 ft. All other openings do not require pilasters, provided the stress levels at that location do not exceed the allowables.

7.10.2 Pilasters should be proportioned to provide the area, section modulus, and moment of inertia requirements needed to satisfy stress requirements. Pilasters should also be detailed to provide adequate stability as column elements and to minimize the effect of stress concentrations.

7.10.3 Pilasters should be continued for a distance of at least one-half the opening width above and below the opening. The rate of corbelling below the opening, if applicable, should not exceed 1 in. per course. A rate of corbelling not to exceed 2 in. per course may be used above the opening; however, care should be taken to avoid abrupt changes that could promote cracking of the liner wall.

7.10.4 If the centroid of the liner cross section at an opening does not coincide with the normal liner center line, the secondary bending effects of the eccentric liner weight should be considered.

7.10.5 If multiple liner openings occur at a given level, the wall sections between openings should be investigated as isolated column elements. These elements, in addition to being checked for stability, should be designed for secondary portal bending effects.

7.10.6 The total stresses through the opening shall not exceed the allowable stresses set forth in 7.6.

7.11 *Liner Reinforcement:*

7.11.1 *Liner Bands*—Steel liner bands should be used to limit vertical liner cracking and to provide overall stability when cracking does occur. Minimum banding will consist of 3 by $\frac{3}{8}$ in. bands at no greater than 5 ft centers. Shear-type connectors are permissible. However, if shear-type connectors are used, at least two tension-type connections per ring should be provided for the purpose of tightening and adjusting the bands. All connections should be designed to develop the

capacity of the band using working strength method. Shear connections should have a minimum of three bolts. It is not necessary that the bands be grouted to obtain continuous bearing.

7.11.2 *Buckstays*—At elevations in the liner where the steel bands are interrupted by openings, the bands should be anchored to vertical steel buckstay members on each side of the opening. These buckstay members should be located adjacent to the pilasters and should extend the same amount above and below the opening as do the pilasters. The buckstay members should be interconnected by a minimum 3 by $\frac{3}{8}$ in. band or other member with an equivalent area above and below the opening. The connection of the band to the buckstay should be designed to develop the capacity of the band using working strength method (see Fig. 3).

7.11.3 *Shear Keys*—In order to maximize the performance of the interrupted bands in the opening areas, there should be minimal deflection of the buckstay at the point where it connects to the band. To eliminate any deflection of the buckstay due to the tension load in the band, its movement should be prevented. This is accomplished through the use of shear keys or local projections of brick from the liner wall surface. The shear keys should project a minimum of 4 in. from the wall, and the area of the shear key should be based on the maximum band force and an allowable brick shear stress of 100 psi (see Fig. 3).

7.11.4 *Lintel Beams*—Lintels should be provided above all openings. They should be designed for the maximum anticipated load of brick and unset mortar during construction. The minimum loading, however, should be no less than that provided by a 60° triangle over the lintel. In order to minimize cracking of the wall above the opening, maximum lintel deflection should not exceed $\frac{1}{600}$ of the span.

7.11.5 *Sill Beams*—In order to minimize cracking at the sills of openings, beams should be installed in the sills of all openings that require pilasters. The sill beam should be designed assuming a rational distribution of loads under the sill, but need not be larger than the lintel beam. Consideration should be given to the corrosion resistance of the sill and lintel beams based on the anticipated operating conditions (see Fig. 3).

7.11.6 *Corrosion Protection*—Corrosion protection of liner reinforcement should be considered for any elements that are potentially exposed to corrosive flue gases or liquid.

7.12 *Deflections and Clearances:*

7.12.1 The minimum annular clearance requirements should be based on the maximum anticipated relative movements between the column and liner. Consideration should be given to any appurtenances, such as internal ladders and platforms, that may encroach on this clearance.

7.12.2 The clearance provided should be based on a rational combination of deflections due to the following:

W —design wind loads on shell,

C_e —design earthquake loads on shell,

L_e —design earthquake loads on liner,

T —temperature differential across the liner diameter under normal operating conditions,

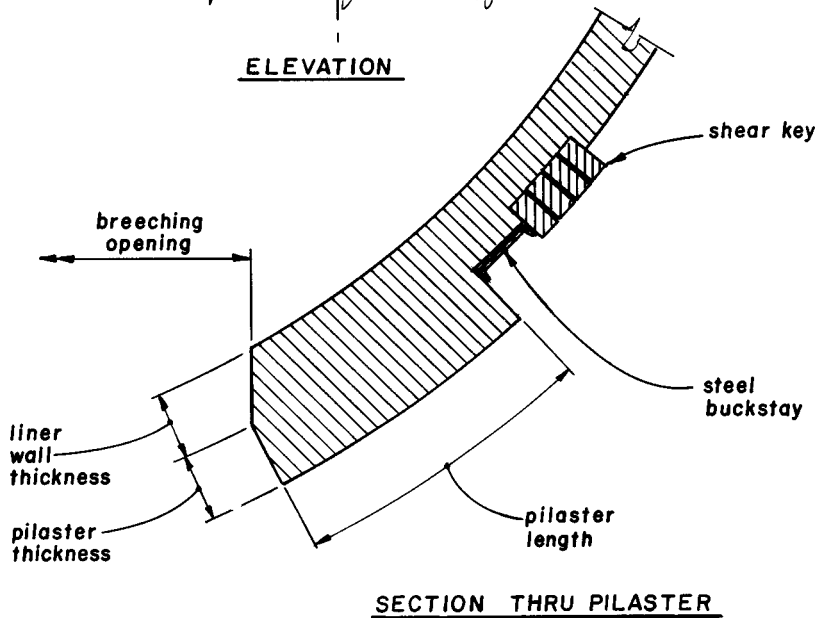
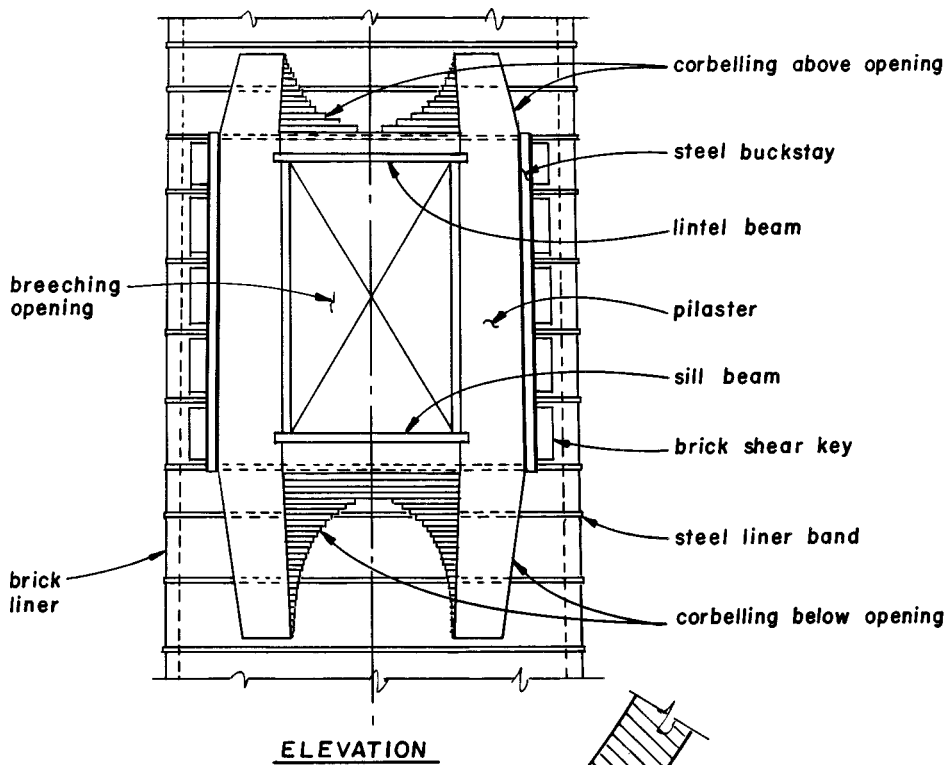

FIG. 3 Breaching Opening

S —sun effect on shell (assume 20°F over entire chimney), and

P —constructional out-of-plumbness of liner with respect to shell (use 1/2 in. per 100 ft height).

7.12.3 The minimum clearances should be established for the deflections due to the following combinations:

$$W/4 + T + P + S \quad (6)$$

$$\{[T + P + S] + [W \text{ or } (C_e + 1.3 L_e)]\} 0.75 \quad (7)$$

NOTE 3—The 1.3 factor is to provide for the possibility that a lower actual Modulus of Elasticity would result in greater earthquake deflections in the liner.

7.12.4 The anticipated relative vertical movement between the shell and liner should also be established to ensure proper

clearances in this direction. All calculated movements should be accommodated in the design of the chimney/liner cap system.

7.12.5 On smaller chimneys in particular, the annular space as established by deflection requirements will not be large enough to permit access for annular inspections. Providing this additional clearance by increasing the chimney diameter is an economic factor that should be considered by the client. Consideration should also be given to locating the ladders and platforms on the exterior of the chimney to reduce annular space requirements.

8. Brick Liner Appurtenances

8.1 *General*—Adequate consideration shall be given to the

design, detailing, and material selection of all liner appurtenances to ensure that the brick lining system as a whole functions properly. This section gives specific recommendations for five major accessories; however, similar consideration should be given to the design and detailing of sample ports, breeching ducts, access doors, and any other appurtenances that comprise the overall chimney lining system. This section also includes sample sketches illustrating some typical details and arrangements for some of the appurtenances described herein. See Fig. 4 for the general arrangement, which shows the various liner elements.

8.2 *Pressurization System:*

8.2.1 The purpose of pressurization is to prevent flue gas from entering the annular space, where acids condensing out of the gas can attack materials in the annulus. Pressurization is generally used in chimneys with brick liners where the operating flue gas pressure in a brick liner exceeds atmospheric pressure, where the flue gas has a relatively high moisture content, and, especially, where the gas temperature is near or below the flue gas dew point. Such conditions can readily force more of the flue gas into the annulus than even a well ventilated air space can readily evacuate. In cases where the flue gas is relatively dry and the pressure in the liner is not significantly above atmospheric pressure, pressurization may not be required. In instances where pressurization is not required, the annulus should be ventilated in accordance with industry standards to purge flue gas.

8.2.2 A pressurization system consists of fans and associated ductwork to force ambient air into the annular space, thus raising the annulus pressure to a level above that developed in the liner. It is recommended that the pressure be maintained at least 1 in. water gage above the maximum internal liner pressure. It is recommended that the number of fans in a system include at least one fan to act as a standby, and that the system include provisions for projected future changes in the internal pressure of the liner. Sufficient control equipment should be provided to ensure the plant operators can determine that the required minimum pressure is being maintained and the fans are operating normally.

8.2.3 It is important that column and liner openings into the annulus be sealed to control the escape of pressurized air. Escape rates should be calculated to account for anticipated losses due to cracks in both the liner brickwork and the column, as well as losses inherent with seals. Potential future cracking should also be considered in loss calculations. The resulting flow rate should, however, be sufficient to maintain annulus air temperature and quality at desirable levels.

8.2.4 Given the fact that initial leakage flow rates for a given pressure are usually less than long-term or design flow rates, means of adjusting or varying flow rates should be considered. For this purpose, suitably designed manually adjustable louvers placed near the chimney top are recommended for controlling air flow and purging air in the annulus.

8.2.5 The choice of fans, drives, controls, and other appurtenances associated with pressurization should be appropriate for the conditions in which they will be used.

8.2.6 When it is necessary for personnel to enter the pressurized annular space, safety measures should be employed that will account for the fact that differential pressure must be released when personnel enter and leave the annulus. In addition, annulus temperature and air quality should allow for essential personnel activities. In order for the pressurization to be effective, it should be regularly inspected and maintained.

8.3 *Floors:*

8.3.1 A protective floor shall be located at the bottom of the liner to provide adequate protection against the operating conditions of the chimney. The floor can coincide with the base of the chimney if the brick liner bears directly on the foundation, or can be on an elevated slab when the liner is supported by a concrete pedestal. Since this floor normally is placed on reinforced concrete, the concrete should be protected against acid attack and high temperature that can cause thermal cracking. Thermal protection can be accomplished by single or multiple layers of one or more of the following materials: acid-resistant chimney brick, insulating block, or hollow tile. If needed, one layer can be arranged such that ventilation from the annulus or outside of the chimney is allowed to circulate through it. Protection from acid condensate can be accomplished by a layer of lead over asphaltic-impregnated felt and an optional layer of acid-resistant mortar. When an elevated floor slab is used at the top of a pedestal, extend the lead pan underneath the liner and form it into a gutter around the perimeter of the base of the liner. This will protect the concrete from acid running down the outside of the pedestal.

8.3.2 The floor should be sloped to permit drainage of

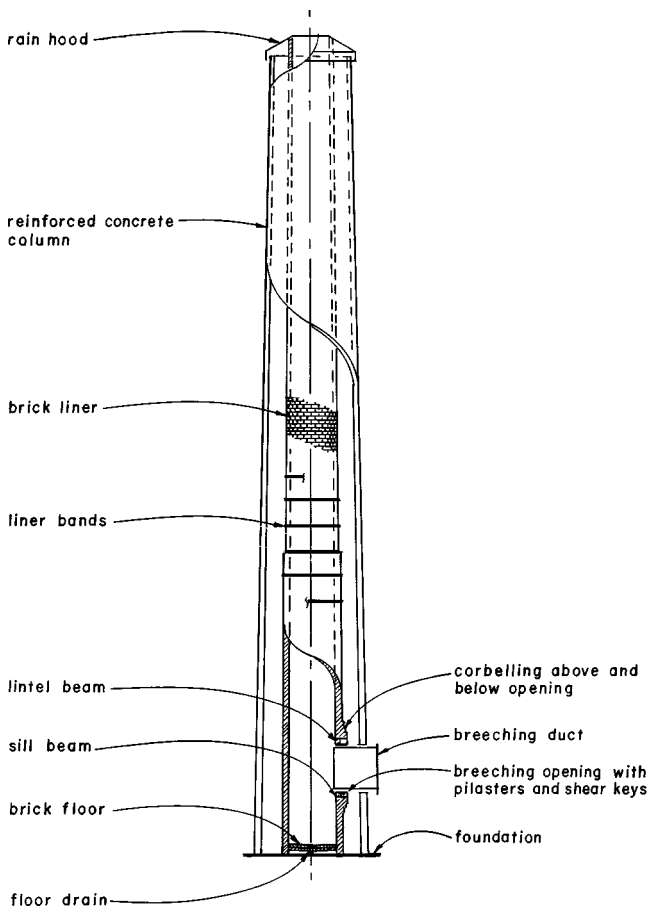

FIG. 4 General Arrangement

condensate and flyash (see Fig. 5).

8.4 *Drains*—A drain should be located in the floor slab at the base of the liner to permit removal of acid condensate and flyash. The drain line should have a minimum horizontal slope of ¼ in./ft to facilitate drainage, and shall be suitably sized for anticipated amounts of liquid collection. A removable grate or a clean-out section should be located in the drain to permit maintenance and cleaning. The drain should be fabricated from a material capable of resisting acid attack from the condensate (see Fig. 5).

8.5 *Hoods and Caps:*

8.5.1 The top of the chimney shell and liner should be provided with a cap constructed of a material capable of resisting acid attack from the flue gas. This is a region of potentially high acid attack because of cooler conditions causing the formation of condensate.

8.5.2 Proper clearance at the cap should be provided to account for lateral movements resulting from chimney sway and differential temperature expansion between the liner and column. The cap should be designed to minimize any loads caused by movement between the shell and liner.

8.5.3 For chimneys requiring pressurization, the cap should be designed to maintain the required annular pressure. Cap details should utilize a fabric seal expansion joint or an alternate arrangement that can accommodate the movement and pressurization requirements.

8.5.4 For chimneys not requiring pressurization, sectional caps may be used to protect the top of the column and liner from acid attack, or a full hood may be utilized to keep rain out of the annulus. See Fig. 6 and Fig. 7 for typical unpressurized and pressurized cap details, respectively.

8.6 *Breeching Seals:*

8.6.1 A flue gas seal should be provided at the interface between the steel breeching and the liner. The purpose of this seal is to prevent flue gas leakage into the annulus area of the chimney.

8.6.2 When selecting materials for this seal flue gas characteristics and the gas pressure within the liner should be considered. The seal must accommodate thermal expansion and displacements of the chimney components. This can be accomplished through the use of a fabric or packed seal similar to that indicated in Fig. 8 and Fig. 9.

9. *Serviceability and Other Considerations*

9.1 *Maintenance and Inspection:*

9.1.1 Since brick liners are passive structures and their appurtenances are, with the exception of pressurization fans, generally non-mechanical, stationary components, they do not require frequent, regular maintenance to keep them functioning. However, brick liners and their appurtenances cannot be ignored from an inspection and maintenance standpoint if they are to be expected to last and provide service for the typical 30- to 50-year life of a plant.

9.1.2 To date, wet scrubbed flue gas produces the most hazardous environment to which brick liners are exposed. Under these conditions, the liner and its appurtenances should receive, as a minimum, thorough annual inspections, at least during the first few years of operation. Liners that are exposed to hot, dry flue gas should be inspected at least every three to five years after an initial annual inspection upon completion of the first year of operation.

9.1.3 A specific maintenance and inspection schedule should be established for the chimney lining system based on the unique operating conditions and particular lining

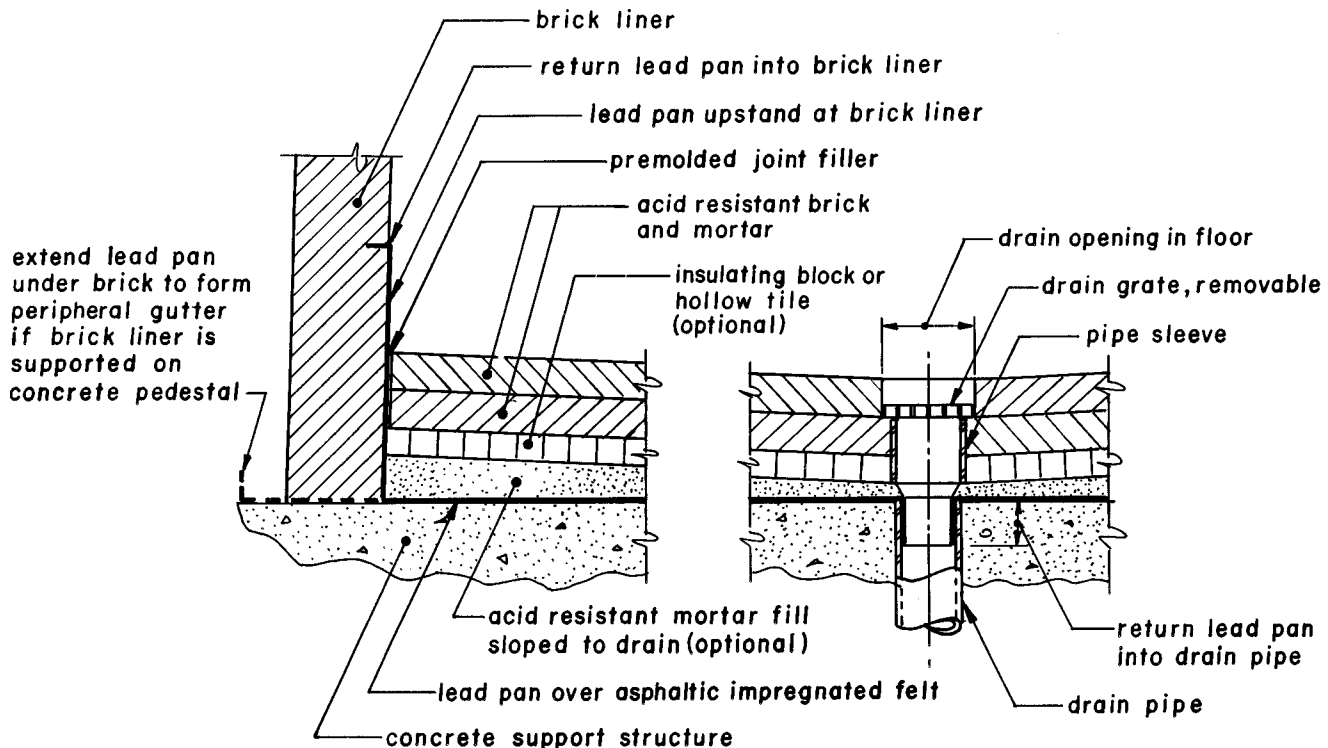
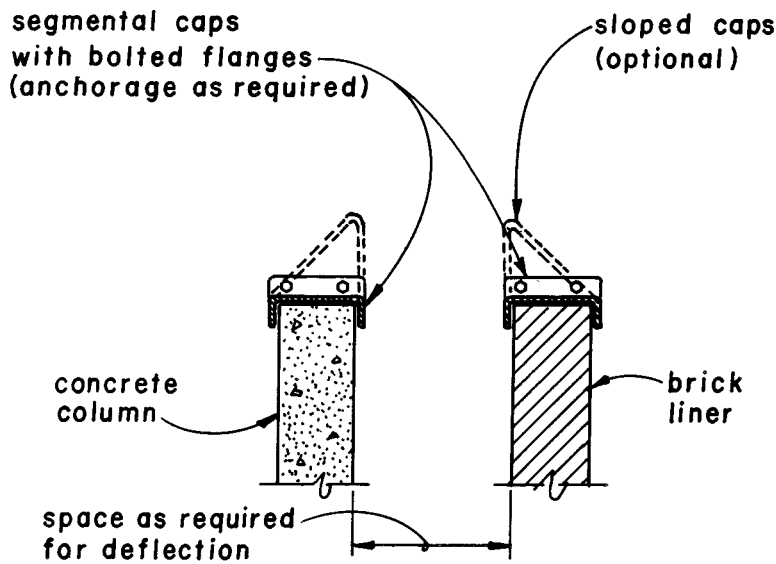
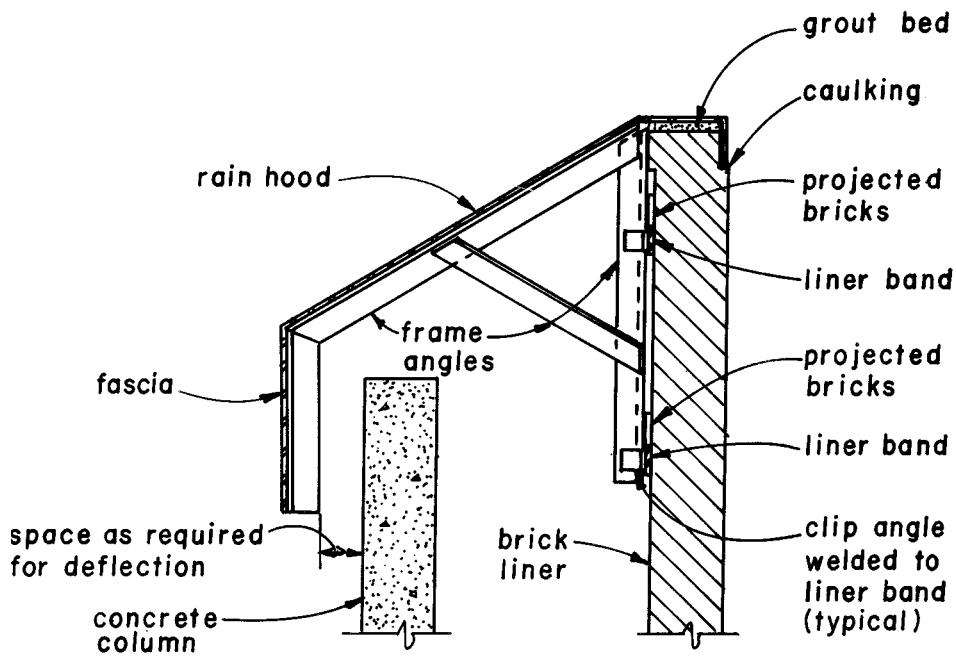

FIG. 5 Liner Floor and Drain



CHIMNEY CAPS



CHIMNEY RAIN HOOD

FIG. 6 Unpressurized Annulus

components at each individual plant.

9.2 Gas Flow and Thermal Considerations:

9.2.1 Gas flow and thermal considerations generally should be consistent with the procedures outlined in the American Society of Civil Engineers' (ASCE) *Design and Construction*

*of Steel Chimney Liners.*⁶

9.2.2 Within the last few years, there have been several instances in which independent brick liners have been found to lean, that is, to have a reduced clearance between the liner and the interior of the outer concrete shell. These leaning liners

⁶ Available from American Society of Civil Engineers, 345 E. 47th St., New York, NY 10017.

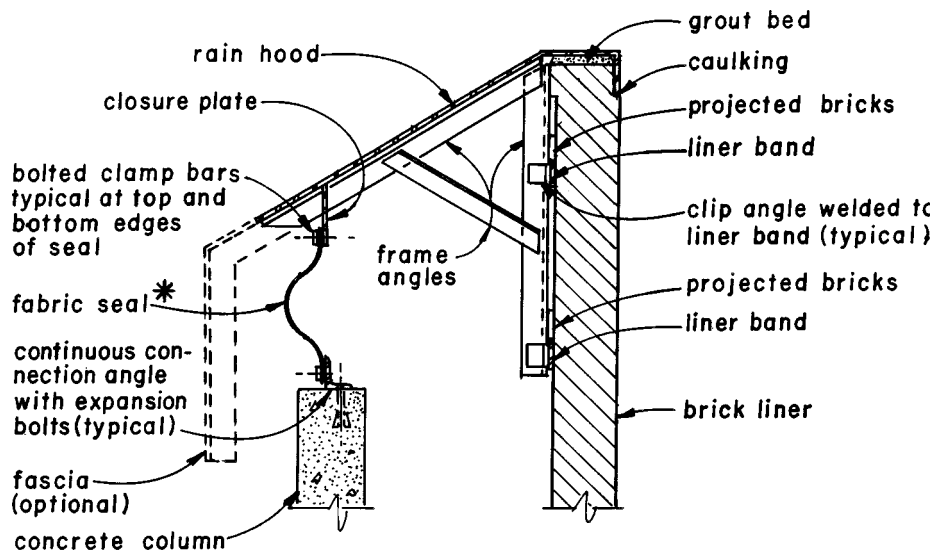

**CHIMNEY RAIN HOOD
WITH FABRIC SEAL**

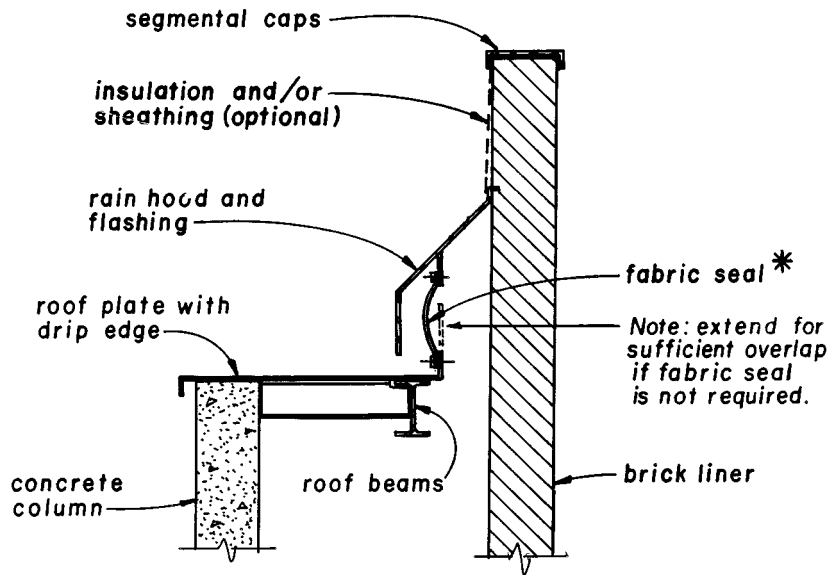

**ROOF DETAILS AT
MULTIPLE LINERS**

* not required for unpressurized annulus

FIG. 7 Pressurized Annulus

have occurred at coal fired power plants with chimneys downstream of wet flue gas desulfurization (FGD) systems. This condition creates the potential for a long, costly outage to repair or modify the liner and are thus a serious problem to the utility industry.

9.2.3 Various possible scenarios can be developed as to the cause of leaning liners in existing chimneys. Recent studies and the available literature related to this subject are limited. Additional research, field investigations, and laboratory analysis are needed to determine the cause or causes of the leaning liners. However, based on available information, there

is a very strong indication that nonuniform temperature and moisture conditions in the liner cross section and at varying heights are involved in causing liner lean. These conditions include differential thermal expansion, moisture expansion due to nonuniform moisture conditions, moisture expansion due to a combination of differential moisture and differential temperature conditions, and growth salts. For chimneys that presently have leaning liners, several modifications that can be considered to prevent additional lean or possibly reduce existing lean are as follows:

9.2.3.1 Installation of a partial or full circumferential target

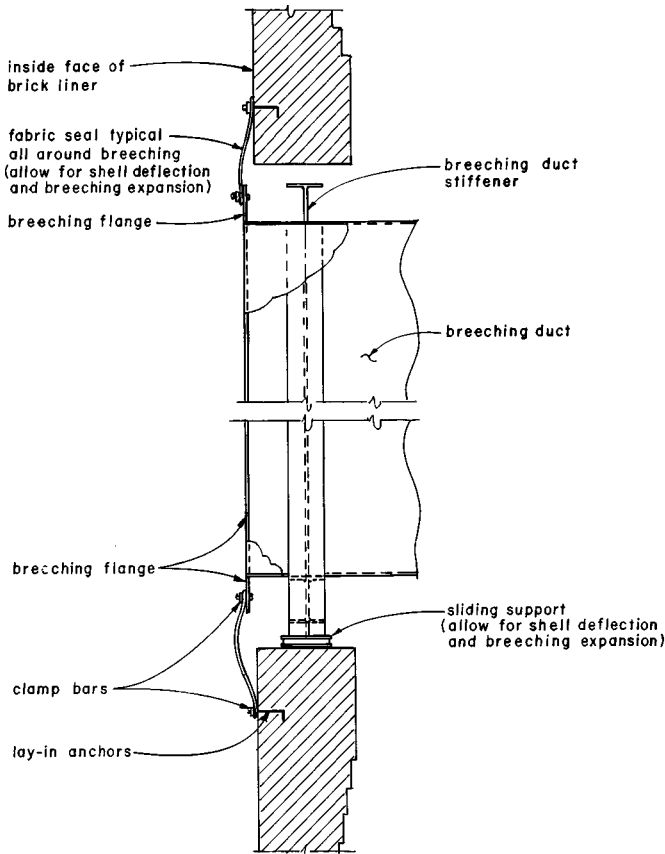

FIG. 8 Fabric Breeching Seal

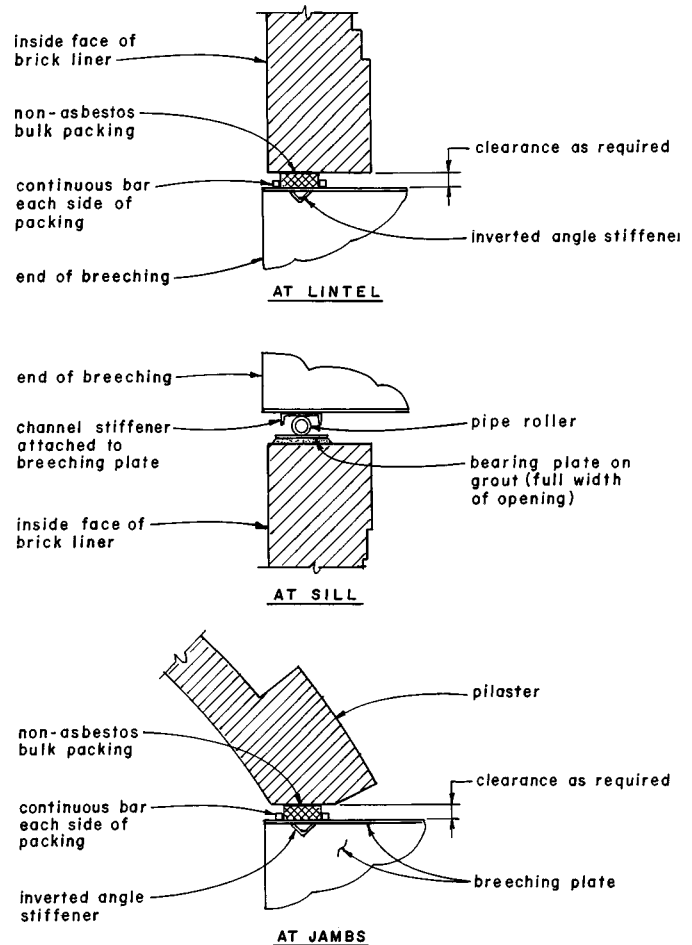

FIG. 9 Packed Breeching Seal

wall in the areas of the liner where nonuniform temperature and moisture conditions exist.

9.2.3.2 Modifications to the top section of the liner to increase the gap between the liner and concrete column.

9.2.3.3 Installation of a counterweight system to reduce the amount of existing lean.

9.2.4 For new chimney liners, the following factors should be considered:

9.2.4.1 Use of plant operating procedures and construction configuration that will avoid mixing scrubbed gas and bypass gas in the liner. Such mixing can result in stratification of the flue gases and thus produces wide variations in temperature and moisture to which the liner wall is exposed.

9.2.4.2 Avoid the over-under breeching arrangement for chimneys handling scrubbed and unscrubbed gases. This creates potential for a “mixing chamber” condition in the liner due to damper leakage or plant operations.

9.2.4.3 It may be possible to minimize liner lean through appropriate selection of material relative to the operating conditions. Recent studies address this subject; however, the available information is very limited and additional research is needed.

9.2.4.4 Use of target walls to provide a protective sacrificial surface that lessens the degree of heat and moisture deposition on the primary wall of a brick liner.

9.2.4.5 Use of a bottom-entry elbow arrangement.

9.2.4.6 Construction of the liner as a series of partial height segments (for example, sectional liner).

9.2.4.7 If target walls are not included in the initial construction, foundation and concrete pedestals may be designed for the possible addition.

9.3 Start-up and Shutdown:

9.3.1 Start-up and shutdown of industrial plants have an impact on liner performance. Some of the items that affect the extent and rate of liner deterioration include the frequency of start-up and shutdown, the moisture and chemistry of the flue gases, and the rate of temperature change of the flue gases during start-up, shutdown, and plant operation. The following are some general recommendations and comments relative to start-up and shutdown of industrial plants:

9.3.1.1 Initial start-up procedures should be followed that would provide ample time for mortar curing and development of compressive strength. It is desirable that initial start-up flue gas temperature be increased slowly to drive off moisture in the wall.

9.3.1.2 In general, washdown of liner walls during outage periods should be avoided.

9.3.1.3 To the extent that is practical, minimize the rate of temperature change of the flue gases during start-up, shutdown, and plant operation.

10. Keywords

10.1 chemical resistant mortar; chimney liner brick; construction requirements; counterweight system; design;

details; leaning liner; masonry strength; pressurization;
stability; stress; target wall

APPENDIX

(Nonmandatory Information)

X1. Additional Material

INTRODUCTION

“Design of Earthquake Resistant Structures,” Rosenblueth, E., ed., John Wiley & Sons, Inc., New York, 1980, pp. 34–36.

Dille, E. R., and Rhudy, R. G., “Leaning Brick Chimney Liners at Coal Fired Power Plants,” as presented to the EPA Symposium on Flue Gas Desulfurization.

“Recommended Lateral Force Requirements,” Seismology Committee, Structural Engineers Association of California (SEOAC), 1987, Table 1-1.

“The Stability of the Lining,” H. van Koten, International Chimney Design Symposium, Munich, October, 1978.

“Tentative Provisions for the Development of Seismic Regulations for Buildings,” including proposed Amendment, Applied Technology Council, April 1984, second printing Chapters 3 and 12.

The American Society for Testing and Materials takes no position respecting the validity of any patent rights asserted in connection with any item mentioned in this standard. Users of this standard are expressly advised that determination of the validity of any such patent rights, and the risk of infringement of such rights, are entirely their own responsibility.

This standard is subject to revision at any time by the responsible technical committee and must be reviewed every five years and if not revised, either reapproved or withdrawn. Your comments are invited either for revision of this standard or for additional standards and should be addressed to ASTM Headquarters. Your comments will receive careful consideration at a meeting of the responsible technical committee, which you may attend. If you feel that your comments have not received a fair hearing you should make your views known to the ASTM Committee on Standards, 100 Barr Harbor Drive, West Conshohocken, PA 19428.