



Designation: C 1314 – 01

## Standard Test Method for Compressive Strength of Masonry Prisms<sup>1</sup>

This standard is issued under the fixed designation C 1314; the number immediately following the designation indicates the year of original adoption or, in the case of revision, the year of last revision. A number in parentheses indicates the year of last reapproval. A superscript epsilon ( $\epsilon$ ) indicates an editorial change since the last revision or reapproval.

### 1. Scope \*

1.1 This test method covers procedures for masonry prism construction and testing, and procedures for determining the compressive strength of masonry,  $f_{m'}$ , used to determine compliance with the specified compressive strength of masonry,  $f'_m$ . When this test method is used for research purposes, the construction and test procedures within serve as a guideline and provide control parameters.

1.2 The values stated in inch-pound units are to be regarded as the standard. The values given in parentheses are for information only.

1.3 *This standard does not purport to address all of the safety concerns, if any, associated with its use. It is the responsibility of the user of this standard to establish appropriate safety and health practices and determine the applicability of regulatory limitations prior to use.*

### 2. Referenced Documents

#### 2.1 ASTM Standards:

C 67 Test Methods for Sampling and Testing Brick and Structural Clay Tile<sup>2</sup>

C 140 Test Methods for Sampling and Testing Concrete Masonry Units and Related Units<sup>2</sup>

C 1093 Practice for Accreditation of Testing Agencies for Unit Masonry<sup>2</sup>

### 3. Terminology

#### 3.1 Definitions:

3.1.1 *set*—a set consists of at least three prisms constructed of the same material and tested at the same age.

#### 3.2 Notations:

3.2.1  $f'_m$ —specified compressive strength of masonry.

3.2.2  $f_{m'}$ —compressive strength of masonry.

3.2.3  $h_p$ —prism height.

3.2.4  $t_p$ —least actual lateral dimension of prism.

### 4. Significance and Use

4.1 This test method provides a means of verifying that

masonry materials used in construction result in masonry that meets the specified compressive strength.

4.2 If this test method is used as a guideline for performing research to determine the effects of various prism construction or test parameters on the compressive strength of masonry, deviations from this test method shall be permitted, provided they are reported. Such research prisms shall not be used to verify compliance with a specified compressive strength of masonry.

4.3 The testing laboratory performing this test method shall be certified in accordance with Practice C 1093.

NOTE 1—Testing should be overseen by an individual who has demonstrated sufficient knowledge and ability through written and practical examination. Such laboratory technician certification programs are available through the National Concrete Masonry Association and others.

### 5. Masonry Prism Construction

5.1 Construct prisms of units representative of those used in the construction. If units have flutes or ribs that project  $\frac{1}{2}$  in. (12.5 mm) or more from the surface of the unit, remove those flutes or ribs by saw cutting flush with the surface of the unit at the base of the flute or rib.

5.2 Construct a set of prisms for each combination of materials and each test age at which the compressive strength of masonry is to be determined.

5.3 Build each prism in an opened, moisture-tight bag large enough to enclose and seal the completed prism. Construct prisms on a flat, level base. Construct prisms in a location where they will remain undisturbed until transported for testing.

5.4 Construct prisms as shown in Fig. 1 with units laid in stack bond in stretcher position. Orient units in the prism as in the corresponding construction. At the time of prism construction, the surfaces of the units shall be free of moisture. Where the corresponding construction is of multi-wythe masonry having wythes composed of different units or mortar, build prisms representative of each different wythe and test separately.

5.5 The length of masonry prisms may be reduced from that of an individual unit by saw cutting units prior to prism construction. Prisms composed of units that contain closed cells shall have at least one complete cell with one full-width cross web on either end (see Fig. 2). Prisms composed of units without closed cells shall have as symmetrical a cross section

<sup>1</sup> This test method is under the jurisdiction of ASTM Committee C15 on Manufactured Masonry Units and is the direct responsibility of Subcommittee C15.04 on Research.

Current edition approved June 10, 2001. Published August 2001. Originally published as C 1314-95. Last previous edition C 1314-00a.

<sup>2</sup> *Annual Book of ASTM Standards*, Vol 04.05.

\*A Summary of Changes section appears at the end of this standard.

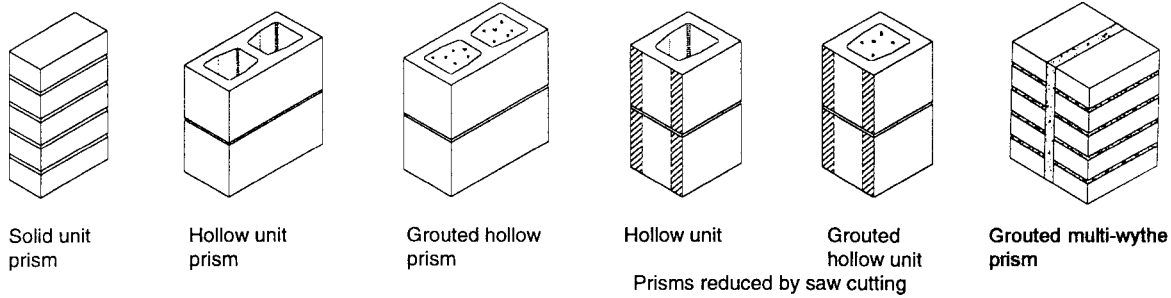

FIG. 1 Masonry Prism Construction

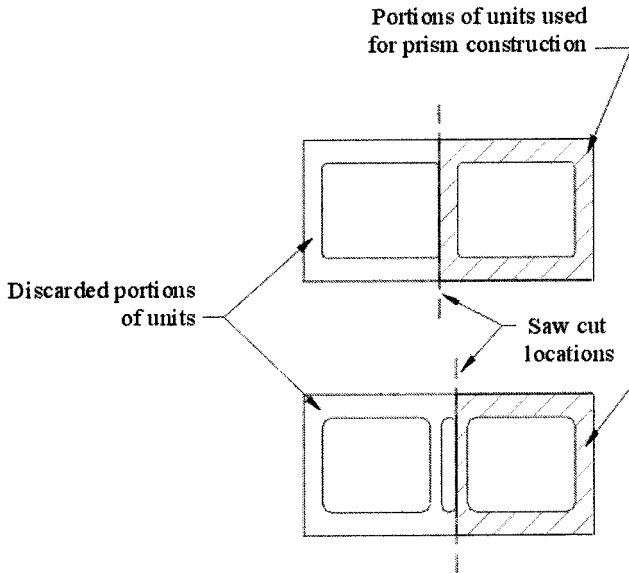

FIG. 2 Reduction of Hollow Units Prior to Prism Construction

as possible. The minimum length of prisms shall be 4 in. (100 mm).

NOTE 2—When using larger masonry units, experience has shown that reducing the length of these units prior to prism construction makes their handling and transportation easier. Thus, these reduced length unit prisms are less likely to be damaged and are more likely to be properly capped and tested. Also, the smaller prism will be less likely to be affected by plate bending effects during testing, as described in Note 4, and will therefore provide a more accurate assessment of the strength of the materials in the masonry prism. For these reasons, the use of reduced length prisms is encouraged.

5.6 Build masonry prisms with full mortar beds (mortar all webs and face shells of hollow units). Use mortar representative of that used in the corresponding construction. Use mortar joint thickness and a method of positioning and aligning units, that are representative of the corresponding construction. Use mortar joints that are cut flush. For prisms to be grouted, remove mortar “fins” that protrude into the grout space.

5.7 Build prisms a minimum of two units high with a height-to-thickness ratio,  $h_p/t_p$ , between 1.3 and 5.0.

5.8 Immediately following the construction of the prism, seal the moisture-tight bag around the prism.

5.9 Grouted Prisms.

5.9.1 Where the corresponding construction is to be solidly grouted, solidly grout the prisms not less than 24 h nor more than 48 h following the construction of the prisms. Use grout

representative of that used in the corresponding construction. Before placing grout, remove mortar droppings from the grout space. Use grout consolidation and reconsolidation procedures representative of those used in the construction. Place additional grout into the prisms as necessary after each consolidation. Screed off excess and finish the grout so that it is level with the top of the prism and in contact with the units at the perimeter of the grout space. Grouted prisms shall contain no reinforcement.

5.9.2 Where the corresponding construction is to be partially grouted, construct two sets of prisms; grout one set solid as described in 5.9.1 and leave the other set ungrouted.

5.9.3 Where open-end units or prisms containing grout between similar wythes are to be grouted, use similar masonry units as forms to confine the grout during placement. Brace forms to prevent displacement during grouting. Grout as described in 5.9.1.

5.9.4 Immediately following the grouting operation, reseal the moisture-tight bag around the prism.

5.10 Keep all prisms from freezing. Do not disturb or move prisms for the first 48 h after construction and grouting. Keep prisms in the moisture-tight bags until 48 h prior to testing.

5.11 Store an indicating maximum-minimum thermometer with the sample and record the maximum and minimum temperatures experienced during the initial 48-h period.

6. Transporting Masonry Prisms

6.1 Prior to transporting prisms, strap or clamp each prism to prevent damage during handling and transportation. Secure prisms to prevent jarring, bouncing, or tipping over during transporting.

7. Curing

7.1 After the initial 48 h of curing, maintain the bagged prisms in an area with a temperature of  $75 \pm 15^\circ\text{F}$  ( $24 \pm 8^\circ\text{C}$ ). Two days prior to testing, remove the moisture-tight bags and continue storing at a temperature of  $75 \pm 15^\circ\text{F}$  ( $24 \pm 8^\circ\text{C}$ ). Test prisms at an age of 28 days or at the designated test ages. Test a set of prisms at each age. Prism age shall be determined from the time of laying units for ungrouted prisms, and from the time of grouting for grouted prisms.

8. Preparation for Testing

8.1 Measuring Prisms—As shown in Fig. 3, measure the length and width at the edges of the top and bottom faces of the prisms to the nearest 0.05 in. (1.3 mm). Determine the length and width by averaging the four measurements of each

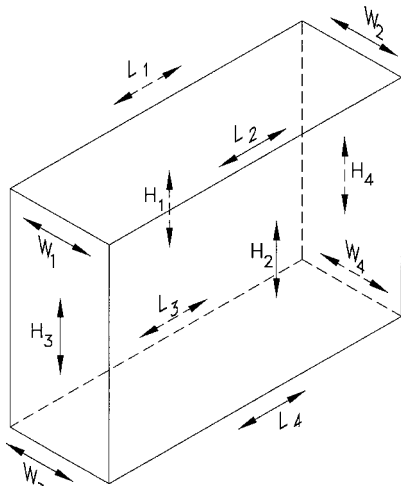

**FIG. 3 Prism Measurement Location**

dimension. Measure the height of the prism at the center of each face to the nearest 0.05 in. (1.3 mm). Determine the height by averaging the four measurements.

**8.2 Capping Prisms**—Smooth irregularities of the prism's bearing surfaces using a method that will not reduce the integrity of the prism. Cap top and bottom of prisms prior to testing with sulfur-filled capping or with high-strength gypsum cement. Sulfur-filled capping material shall be 40 to 60 % sulfur by weight; the remainder may be ground fire clay or other suitable inert material passing a No. 100 (150 mm) sieve, with or without a plasticizer. Spread the capping material over a level surface that is plane within 0.003 in. (0.076 mm) in 16 in. (406 mm). Bring the surface to be capped into contact with the capping compound; firmly press down the specimen, holding the prism so that its axis is at right angles to the capping surfaces, and the capped ends are parallel within one degree. A spirit level (for example, bulls eye level, torpedo level) or equivalent method shall be used during the capping process to comply with these prism alignment criteria. The average thickness of the cap shall not exceed 1/8 in. (3 mm). Age the caps at least 2 h before testing the specimens.

## 9. Procedure

**9.1 Test Apparatus**—The test machine shall have an accuracy of plus or minus 1.0 % over the anticipated load range. The upper platen shall be a spherically seated, hardened metal block firmly attached at the center of the upper head of the machine. The center of the sphere shall lie at the center of the surface held in its spherical seat but shall be free to turn in any direction, and its perimeter shall have at least 1/4 in. (6.3 mm) clearance from the head to accommodate specimens whose bearing surfaces are not parallel. The diameter of the upper platen (determined in accordance with A1.3) shall be at least 6 in. (150 mm). A hardened metal bearing plate may be used beneath the specimen to minimize wear of the lower platen of the machine.

**9.1.1** When the bearing area of the upper platen or lower platen is not sufficient to cover the area of the specimen, a single steel bearing plate with a thickness equal to at least the distance from the edge of the platen to the most distant corner

of the specimen shall be placed between the platen and the capped specimen. The length and width of the steel plate shall be at least 1/4 in. (6 mm) greater than the length and width of the prisms.

**9.1.2** The surfaces of the platen or plate intended for contact with the specimen shall have a hardness not less than HRC 60 (BHN 620). The surfaces of the platen and plate shall not depart from plane surfaces by more than 0.001 in. (0.03 mm) in any 6-in. (150-mm) dimension.

**NOTE 3**—Annex A1 includes guidance on determining the required plate thicknesses based on the configurations of the test specimen and the test machine.

**NOTE 4**—Research has shown that the thickness of bearing plates has a significant effect on the tested compressive strength of masonry prisms when the bearing area of the plate is not sufficient to cover the area of the specimen. Plate bending results in nonuniform stress distributions that can influence the failure mechanisms of the tested specimens. The magnitude of this effect is controlled by the stiffness of the plate, the size of the specimen tested, and the strength of the specimen. Tested compressive strengths will typically increase with increased plate thickness and with reduced distance to the furthest corner of the specimen. Some testing laboratories have machine size limitations that limit the practicality of eliminating plate bending entirely. Therefore, the plate thickness requirements in 9.1 are intended to provide an adequate level of accuracy in the compression test results so as to conform to the limits of practicality of the testing laboratory.

**9.2 Installing the Prism in The Test Machine**—Wipe clean the bearing faces of the platens, the bearing plates, and the test specimen. Place the test specimen on the lower platen or bearing plate. Align both centroidal axes of the specimen with the center of thrust of the machine. As the spherically seated upper platen or plate is brought to bear on the specimen, rotate the movable portion of the upper platen gently by hand so that uniform seating is obtained.

**9.3 Loading**—Apply the load to the prism up to one-half of the expected total load at any convenient rate. Apply the remaining load at a uniform rate in not less than 1 nor more than 2 min.

**9.4 Observations**—Describe the type of failure as fully as possible or illustrate, or both, crack patterns and spalling on a sketch or photograph. Note whether failure occurred on one side or one end of the prism prior to failure of the opposing side or end of the prism. Identify type of fracture using Fig. 4.

## 10. Calculation

**10.1** Calculate test results as follows:

**10.1.1 Net Cross-Sectional Area**—Take the net cross-sectional area of ungrouted prisms as the net cross-sectional area of masonry units, which are cut as in the prism, determined by measurement or from a representative sample of units that are cut as in the prism, in accordance with Test Methods C 140 for concrete masonry and with Test Methods C 67 for clay masonry. Determine net cross-sectional area of fully grouted prisms by multiplying the length and width of the prism (see 8.1).

**NOTE 5**—Net area of concrete masonry units other than 100 % solid units is determined by Test Methods C 140. Net area determined by Test Methods C 140 is usually slightly different from the minimum net cross-sectional area.

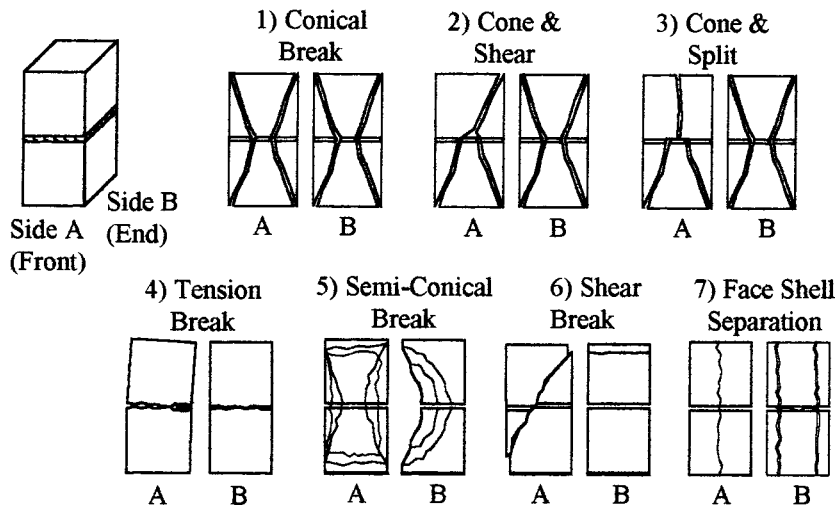

FIG. 4 Sketches of Types of Fracture

10.1.1.1 Consider clay masonry units whose net cross-sectional area is at least 75 % of the gross cross-sectional area as 100 % solid.

10.1.2 *Masonry Prism Strength*—Calculate each masonry prism strength by dividing each prism’s maximum compressive load sustained by the net cross-sectional area of that prism, and express the result to the nearest 10 psi (69 kPa).

10.1.2.1 Where sets of grouted and ungrouted prisms are tested, calculate the masonry prism strength separately for the grouted set and the ungrouted set.

10.1.2.2 Where a set of prisms is tested for each wythe of a multi-wythe wall, calculate the masonry prism strength for each wythe.

10.1.3 *Compressive Strength of Masonry:*

10.1.3.1 Calculate the  $h_p/t_p$  ratio for each prism using the height and the least lateral dimension of that prism. Determine the correction factor from Table 1. If a prism’s height to thickness ratio lies between the  $h_p/t_p$  values of Table 1, determine the corresponding correction factor by linear interpolation between the given values.

10.1.3.2 Multiply the masonry prism strength by the correction factor for the respective prism.

10.1.3.3 Calculate the compressive strength of masonry,  $f_{mr}$ , for each set of prisms by averaging the values obtained.

11. Report

11.1 Report the following information:

11.1.1 Name of testing laboratory.

11.1.2 Designation of each prism tested and description of prism including width, height, and length dimensions;  $h_p/t_p$  ratio; mortar type; and grout and masonry unit used in the construction.

TABLE 1 Height to Thickness Correction Factors for Masonry Prism Compressive Strength

|                   |      |      |     |      |      |      |      |
|-------------------|------|------|-----|------|------|------|------|
| $h_p/t_p^A$       | 1.3  | 1.5  | 2.0 | 2.5  | 3.0  | 4.0  | 5.0  |
| Correction Factor | 0.75 | 0.86 | 1.0 | 1.04 | 1.07 | 1.15 | 1.22 |

<sup>A</sup>  $h_p/t_p$ —Ratio of prism height to least lateral dimension of prism.

11.1.3 The maximum and minimum temperature experienced by the prisms during the first 48 h after construction and grouting.

11.1.4 Age of prism at time of test.

11.1.5 Maximum compressive load sustained by each prism in pounds force or newtons.

11.1.6 Net cross-sectional area of each prism in square inches or square millimetres, and method used to calculate area.

11.1.7 Test observations for each prism in accordance with 9.4.

11.1.7.1 Type of fracture (see Fig. 4)

11.1.8 Compression machine spherical head diameter (or projected diameter if applicable), upper bearing plate thickness requirement based on size of tested specimen, and thickness of upper bearing plate used.

11.1.9 Compression machine lower platen dimensions, lower bearing plate thickness requirement based on size of tested specimen, and thickness of lower bearing plate used.

11.1.10 Compressive strength of each prism calculated to the nearest 10 psi or 69 kPa (see 10.1.3.2).

11.1.11 Compressive strength of masonry,  $f_{mr}$ , for each set of prisms calculated to the nearest 10 psi or 69 kPa (see 10.1.3.3).

12. Precision and Bias

12.1 Due to the variety of materials and combinations of materials involved, no statement is made concerning the precision or bias of this test method. Sufficient test data for all materials and combinations of materials are not available to permit the development of precision and bias statements.

13. Keywords

13.1 compressive strength of masonry; masonry prism; masonry prism strength; specified compressive strength of masonry

ANNEX

(Mandatory Information)

A1. DETERMINING PLATE THICKNESS REQUIREMENTS FOR COMPRESSION TESTING

A1.1 *Scope*—This annex provides additional information to assist in determining the plate thickness requirements for compression testing as written in 9.1.

A1.2 *Test Equipment*—Fig. A1.1 shows the location of the referenced test equipment as used in the compression testing of masonry prisms.

A1.3 *Determining the Diameter of the Upper Platen*—As shown in Fig. A1.2, the diameter of the upper platen is considered in this test method to be equal to the maximum horizontal dimension measured across the circle created by the spherical portion of the upper platen (this measured diameter may differ for the actual geometric diameter of the sphere based on its curvature). If the upper platen includes a non-spherical section that was manufactured integrally with the spherical head from a single piece of steel, the diameter of the upper platen is considered to be the diameter of the spherical seat on the upper surface of the upper platen plus the thickness of the non-spherical section ( $t_{PL}$ ). However, the diameter of the upper platen shall not be greater than the minimum horizontal dimension of the upper platen.

A1.4 *Distance from Edge of Platen to Furthest Corner of Test Specimen*—Determine the distance from the edge of the platen to the furthest corner of the specimen as follows:

A1.4.1 Locate the specimen's center of mass, and mark it on top of the specimen.

A1.4.2 Determine to the nearest 1/8 in. (3 mm) the distance from the center of mass of the specimen to the furthest corner or edge of the test specimen. Record this distance as  $A$ .

A1.4.3 The distance from the platen to the furthest corner of the test specimen is obtained by the following equation (see Fig. A1.3):

$$d = A - \frac{D_{PL}}{2} \tag{A1.1}$$

where:

$d$  = distance from the platen to the furthest corner of the test specimen, in. (mm), and

$A$  = distance from the center of mass of the specimen to the furthest corner of the test specimen, in. (mm).

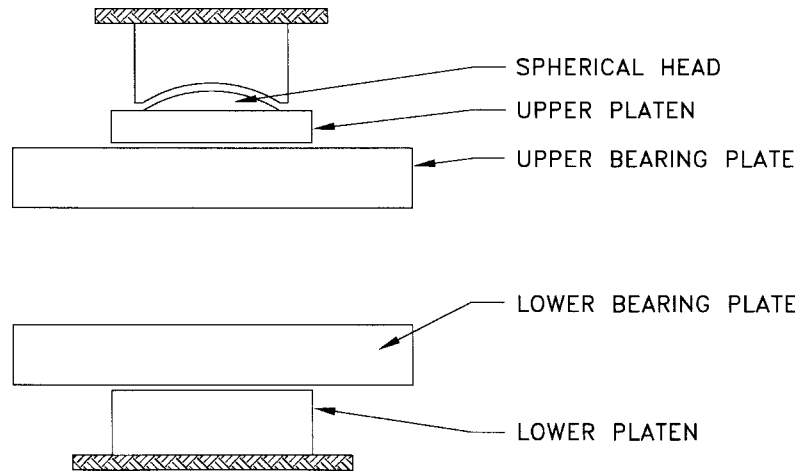
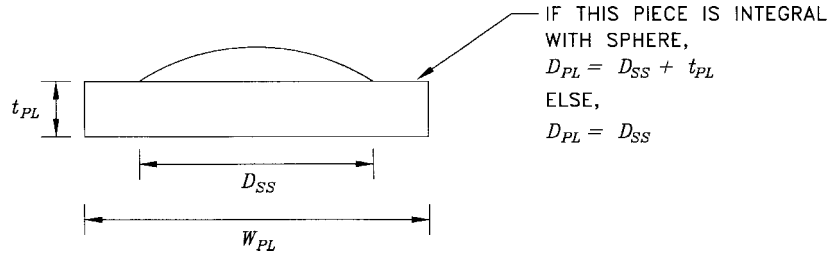

FIG. A1.1 Equipment Used for Compression Testing



where:

- $D_{SS}$  = measured diameter of spherical seat,
- $D_{PL}$  = calculated diameter of upper platen,
- $W_{PL}$  = measured minimum width of upper platen, and
- $t_{PL}$  = measured thickness of nonspherical section of upper platen.

FIG. A1.2 Diameter of the Upper Platen

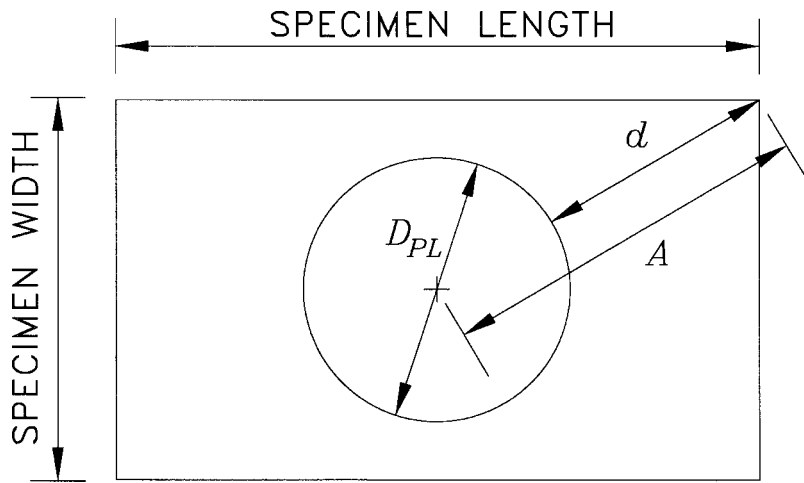

FIG. A1.3 Distance from Platen to Furthest Corner of Test Specimen

## APPENDIX

(Nonmandatory Information)

### X1. SAMPLE TEST REPORT

X1.1 Fig. X1.1 is a sample test report.

**ASTM C 1314-\_\_\_ Test Report:**  
**Constructing and Testing Masonry Prisms Used to Determine**  
**Compliance with Specified Compressive Strength of Masonry**

Report No.: \_\_\_\_\_  
 Report Date: \_\_\_\_\_

Client Name: \_\_\_\_\_ Testing Lab Name: \_\_\_\_\_  
 Address: \_\_\_\_\_ Address: \_\_\_\_\_

Project Identification: \_\_\_\_\_  
 Prism Identification: \_\_\_\_\_

Specified Compressive Strength of Masonry: \_\_\_\_\_ psi

|  |  |
|--|--|
| <b>Prism Details:</b>                  | <b>Masonry Unit Information:</b>         |
| Number of Mortar Bed Joints: _____     | Unit Supplier: _____                     |
| Number of Masonry Units Used: _____    | Unit Dimensions: _____                   |
| Date Constructed: _____                | Description of Unit Configuration: _____ |
| Date Grouted: _____                    |  |
| Date Retrieved from Site: _____        | Unit Net Area (hollow units): _____      |
| Date Delivered to Lab: _____           | Type of Unit: _____                      |
| Date Tested: _____                     |  |
| Prisms Constructed By: _____           | <b>Grout Information</b>                 |
| Max/Min Temperature (1st 48 hr.) _____ | Grout Supplier / Preparer: _____         |
|  | Grout Type / Description: _____          |
|  | Grout Slump (ASTM C 143): _____          |
| <b>Mortar Information</b>              | Method of Consolidation: _____           |
| Mortar Supplier / Preparer: _____      |  |
| Mortar Type / Description: _____       |  |

**Compression Test Machine Information**

Diameter of Spherical Seat: \_\_\_\_\_

Required Upper Bearing Plate Thickness: \_\_\_\_\_ Provided Upper Bearing Plate Thickness: \_\_\_\_\_

Required Lower Bearing Plate Thickness: \_\_\_\_\_ Provided Lower Bearing Plate Thickness: \_\_\_\_\_

**Tested Prism Properties:**

| Prism No. | Age at Test (days) | Avg. Width (in.) | Avg. Height (in.) | Avg. Length (in.) | Net Area (in <sup>2</sup> ) | Max Load (lb.) | Net Compr. Strength (psi) | h <sub>p</sub> /t <sub>p</sub> Ratio | Corrected Net Strength (psi) | CF*   |
|-----------|--------------------|------------------|-------------------|-------------------|-----------------------------|----------------|---------------------------|--------------------------------------|------------------------------|-------|
|           |                    |                  |                   |                   |                             |                |                           |                                      |                              |       |
| _____     | _____              | _____            | _____             | _____             | _____                       | _____          | _____                     | _____                                | _____                        | _____ |
| _____     | _____              | _____            | _____             | _____             | _____                       | _____          | _____                     | _____                                | _____                        | _____ |
| _____     | _____              | _____            | _____             | _____             | _____                       | _____          | _____                     | _____                                | _____                        | _____ |

\* Height to thickness correction factor from Table 1 of ASTM C 1314-\_\_\_

Compressive Strength of Masonry (average for the set of three prisms): **f<sub>mt</sub>** = \_\_\_\_\_ psi

**Sketches or Photos of Prism Failure Modes**

|                 |                 |                 |
|-----------------|-----------------|-----------------|
| Prism No. _____ | Prism No. _____ | Prism No. _____ |
| sketch or photo | sketch or photo | sketch or photo |

\_\_\_\_\_  
 Signature  
 Name of Lab Director

**FIG. X1.1 Sample Test Report**

**SUMMARY OF CHANGES**

Committee C15 has identified the location of selected changes to this standard since C 1314-00a was published in the 2000 *Annual Book of Standards*, Vol 04.05.

(1) New section 11.1.7.1 was added to require reporting type of fracture and new Fig. 4 was added.

*ASTM International takes no position respecting the validity of any patent rights asserted in connection with any item mentioned in this standard. Users of this standard are expressly advised that determination of the validity of any such patent rights, and the risk of infringement of such rights, are entirely their own responsibility.*

*This standard is subject to revision at any time by the responsible technical committee and must be reviewed every five years and if not revised, either reapproved or withdrawn. Your comments are invited either for revision of this standard or for additional standards and should be addressed to ASTM International Headquarters. Your comments will receive careful consideration at a meeting of the responsible technical committee, which you may attend. If you feel that your comments have not received a fair hearing you should make your views known to the ASTM Committee on Standards, at the address shown below.*

*This standard is copyrighted by ASTM International, 100 Barr Harbor Drive, PO Box C700, West Conshohocken, PA 19428-2959, United States. Individual reprints (single or multiple copies) of this standard may be obtained by contacting ASTM at the above address or at 610-832-9585 (phone), 610-832-9555 (fax), or [service@astm.org](mailto:service@astm.org) (e-mail); or through the ASTM website ([www.astm.org](http://www.astm.org)).*