



Designation: C 1314 – 03a

Standard Test Method for Compressive Strength of Masonry Prisms¹

This standard is issued under the fixed designation C 1314; the number immediately following the designation indicates the year of original adoption or, in the case of revision, the year of last revision. A number in parentheses indicates the year of last approval. A superscript epsilon (ϵ) indicates an editorial change since the last revision or reapproval.

1. Scope*

1.1 This test method covers procedures for masonry prism construction and testing, and procedures for determining the compressive strength of masonry, $f_{m'}$, used to determine compliance with the specified compressive strength of masonry, f'_m . When this test method is used for research purposes, the construction and test procedures within serve as a guideline and provide control parameters.

1.2 The values stated in inch-pound units are to be regarded as the standard. The values given in parentheses are for information only.

1.3 *This standard does not purport to address all of the safety concerns, if any, associated with its use. It is the responsibility of the user of this standard to establish appropriate safety and health practices and determine the applicability of regulatory limitations prior to use.*

2. Referenced Documents

2.1 ASTM Standards:

- C 67 Test Methods for Sampling and Testing Brick and Structural Clay Tile²
- C 136 Test Method for Sieve Analysis of Fine and Coarse Aggregates³
- C 140 Test Methods for Sampling and Testing Concrete Masonry Units and Related Units²
- C 143 Test Method for Slump of Hydraulic Cement Concrete³
- C 144 Specification for Aggregate for Masonry Mortar²
- C 270 Specification for Mortar for Unit Masonry³
- C 476 Specification for Grout for Masonry²
- C 780 Test Method for Preconstruction and Construction Evaluation of Mortars for Plain and Reinforced Unit Masonry²
- C 1019 Test Method for Sampling and Testing Grout²
- C 1093 Practice for Accreditation of Testing Agencies for Unit Masonry²
- C 1552 Practice for Capping Concrete Masonry Units, Re-

- lated Units, and Masonry Prisms for Compression Testing²
- E 105 Practice for Probability Sampling of Materials⁴
- E 111 Test Method for Young's Modulus, Tangent Modulus, and Chord Modulus⁵

3. Terminology

3.1 Definitions:

3.1.1 *set*—a set consists of at least three prisms constructed of the same material and tested at the same age.

3.2 Notations:

- 3.2.1 f'_m —specified compressive strength of masonry.
- 3.2.2 $f_{m'}$ —compressive strength of masonry.
- 3.2.3 h_p —prism height.
- 3.2.4 t_p —least actual lateral dimension of prism.

4. Significance and Use

4.1 This test method provides a means of verifying that masonry materials used in construction result in masonry that meets the specified compressive strength.

4.2 If this test method is used as a guideline for performing research to determine the effects of various prism construction or test parameters on the compressive strength of masonry, deviations from this test method shall be reported. Such research prisms shall not be used to verify compliance with a specified compressive strength of masonry.

NOTE 1—The testing laboratory performing this test method should be evaluated in accordance with Practice C 1093.

4.2.1 Appendix X2 includes guidance information for the researcher on aspects of materials, construction, and analysis.

5. Masonry Prism Construction

5.1 Construct prisms of units representative of those used in the construction. If units have flutes or ribs that project $\frac{1}{2}$ in. (12.5 mm) or more from the surface of the unit, remove those flutes or ribs by saw cutting flush with the surface of the unit at the base of the flute or rib.

5.2 Construct a set of prisms for each combination of materials and each test age at which the compressive strength of masonry is to be determined.

5.3 Build each prism in an opened, moisture-tight bag large enough to enclose and seal the completed prism. Construct

¹ This test method is under the jurisdiction of ASTM Committee C15 on Manufactured Masonry Units and is the direct responsibility of Subcommittee C15.04 on Research.

Current edition approved June 10, 2003. Published September 2003. Originally approved in 1995. Last previous edition approved in 2003 as C 1314-03.

² *Annual Book of ASTM Standards*, Vol 04.05.

³ *Annual Book of ASTM Standards*, Vol 04.02.

⁴ *Annual Book of ASTM Standards*, Vol 14.02.

⁵ *Annual Book of ASTM Standards*, Vol 03.01.

*A Summary of Changes section appears at the end of this standard.

prisms on a flat, level base. Construct prisms in a location where they will remain undisturbed until transported for testing.

5.4 Construct prisms as shown in Fig. 1 with units laid in stack bond in stretcher position. Orient units in the prism as in the corresponding construction. At the time of prism construction, the surfaces of the units shall be free of moisture. Where the corresponding construction is of multi-wythe masonry having wythes composed of different units or mortar, build prisms representative of each different wythe and test separately.

5.5 Build prisms with full-size or reduced length units. Any required saw cutting shall be performed on units prior to prism construction. The moisture content(s) of units used to construct prisms shall be representative of those used in construction. Prisms composed of units that contain closed cells shall have at least one complete cell with one full-width cross web on either end (see Fig. 2). Prisms composed of units without closed cells shall have as symmetrical a cross section as possible. The minimum length of prisms shall be 4 in. (100 mm).

NOTE 2—When using larger masonry units, experience has shown that reducing the length of these units prior to prism construction makes their handling and transportation easier. Thus, these reduced length unit prisms are less likely to be damaged and are more likely to be properly capped and tested. Also, the smaller prism will be less likely to be affected by plate bending effects during testing, as described in Note 4, and will therefore provide a more accurate assessment of the strength of the materials in the masonry prism. For these reasons, the use of reduced length prisms is encouraged.

5.6 Build masonry prisms with full mortar beds (mortar all webs and face shells of hollow units). Use mortar representative of that used in the corresponding construction. Use mortar joint thickness and a method of positioning and aligning units, that are representative of the corresponding construction. Use mortar joints that are cut flush. For prisms to be grouted, remove mortar “fins” that protrude into the grout space.

5.7 Build prisms a minimum of two units high with a height-to-thickness ratio, h_p/t_p , between 1.3 and 5.0.

5.8 Immediately following the construction of the prism, seal the moisture-tight bag around the prism.

5.9 Grouted Prisms.

5.9.1 Where the corresponding construction is to be solidly grouted, solidly grout the prisms not less than 24 h nor more than 48 h following the construction of the prisms. Use grout representative of that used in the corresponding construction.

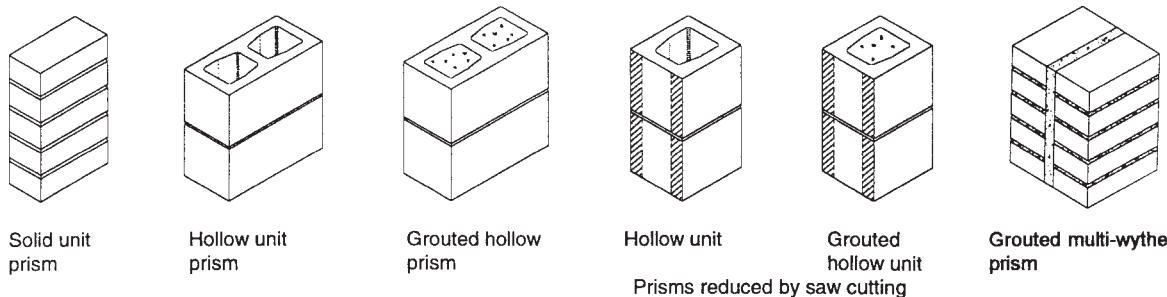

FIG. 1 Masonry Prism Construction

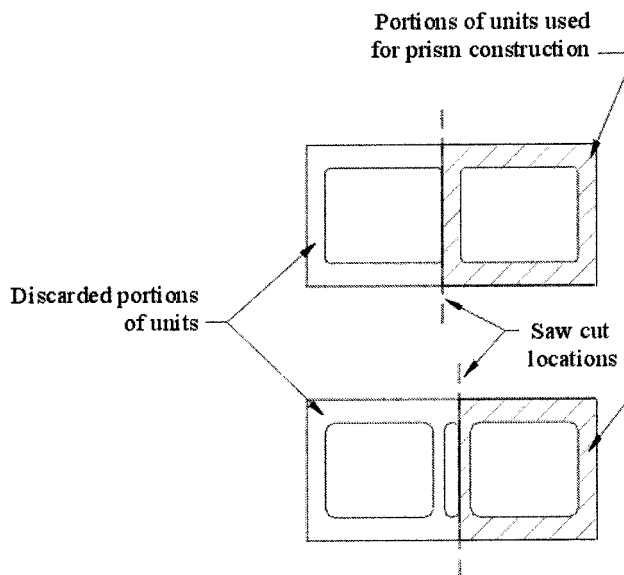

FIG. 2 Reduction of Hollow Units Prior to Prism Construction

Before placing grout, remove mortar droppings from the grout space. Use grout consolidation and reconsolidation procedures representative of those used in the construction. Place additional grout into the prisms as necessary after each consolidation. Screed off excess and finish the grout so that it is level with the top of the prism and in contact with the units at the perimeter of the grout space. Grouted prisms shall contain no reinforcement.

5.9.2 Where the corresponding construction is to be partially grouted, construct two sets of prisms; grout one set solid as described in 5.9.1 and leave the other set ungrouted.

5.9.3 Where open-end units or prisms containing grout between similar wythes are to be grouted, use similar masonry units as forms to confine the grout during placement. Brace forms to prevent displacement during grouting. Grout as described in 5.9.1.

5.9.4 Immediately following the grouting operation, reseal the moisture-tight bag around the prism.

5.10 Keep all prisms from freezing. Do not disturb or move prisms for the first 48 h after construction and grouting. Keep prisms in the moisture-tight bags until 48 h prior to testing.

5.11 Store an indicating maximum-minimum thermometer with the sample and record the maximum and minimum temperatures experienced during the initial 48-h period.

6. Transporting Masonry Prisms

6.1 Prior to transporting prisms, strap or clamp each prism to prevent damage during handling and transportation. Secure prisms to prevent jarring, bouncing, or tipping over during transporting.

7. Curing

7.1 After the initial 48 h of curing, maintain the bagged prisms in an area with a temperature of $75 \pm 15^\circ\text{F}$ ($24 \pm 8^\circ\text{C}$). Two days prior to testing, remove the moisture-tight bags and continue storing at a temperature of $75 \pm 15^\circ\text{F}$ ($24 \pm 8^\circ\text{C}$). Test prisms at an age of 28 days or at the designated test ages. Test a set of prisms at each age. Prism age shall be determined from the time of laying units for ungrouted prisms, and from the time of grouting for grouted prisms.

8. Preparation for Testing

8.1 *Measuring Prisms*—As shown in Fig. 3, measure the length and width at the edges of the top and bottom faces of the prisms to the nearest 0.05 in. (1.3 mm). Determine the length and width by averaging the four measurements of each dimension. Measure the height of the prism at the center of each face to the nearest 0.05 in. (1.3 mm). Determine the height by averaging the four measurements.

8.2 *Capping Prisms*—Cap prisms in accordance with Practice C 1552.

9. Procedure

9.1 *Test Apparatus*—The test machine shall have an accuracy of plus or minus 1.0 % over the anticipated load range. The upper platen shall be a spherically seated, hardened metal block firmly attached at the center of the upper head of the machine. The center of the sphere shall lie at the center of the surface held in its spherical seat but shall be free to turn in any direction, and its perimeter shall have at least $\frac{1}{4}$ in. (6.3 mm) clearance from the head to accommodate specimens whose bearing surfaces are not parallel. The diameter of the upper platen (determined in accordance with A1.3) shall be at least 6 in. (150 mm). A hardened metal bearing plate used beneath the

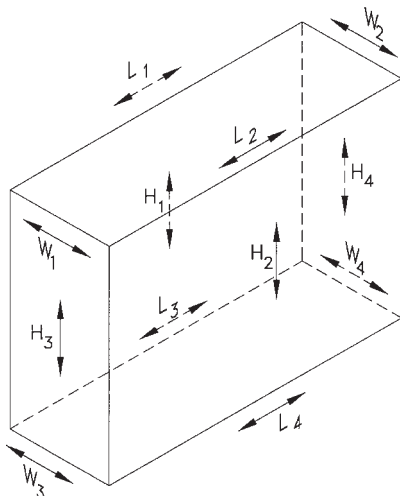

FIG. 3 Prism Measurement Location

specimen is not required, but has been found to minimize wear of the lower platen of the machine.

9.1.1 When the bearing area of the upper platen or lower platen is not sufficient to cover the area of the specimen, a single steel bearing plate with a thickness equal to at least the distance from the edge of the platen to the most distant corner of the specimen shall be placed between the platen and the capped specimen. The length and width of the steel plate shall be at least $\frac{1}{4}$ in. (6 mm) greater than the length and width of the prisms.

9.1.2 The surfaces of the platen or plate intended for contact with the specimen shall have a hardness not less than HRC 60 (BHN 620). The surfaces of the platen and plate shall not depart from plane surfaces by more than 0.001 in. (0.03 mm) in any 6-in. (150-mm) dimension.

NOTE 3—Annex A1 includes guidance on determining the required plate thicknesses based on the configurations of the test specimen and the test machine.

NOTE 4—Research has shown that the thickness of bearing plates has a significant effect on the tested compressive strength of masonry prisms when the bearing area of the plate is not sufficient to cover the area of the specimen. Plate bending results in nonuniform stress distributions that can influence the failure mechanisms of the tested specimens. The magnitude of this effect is controlled by the stiffness of the plate, the size of the specimen tested, and the strength of the specimen. Tested compressive strengths will typically increase with increased plate thickness and with reduced distance to the furthest corner of the specimen. Some testing laboratories have machine size limitations that limit the practicality of eliminating plate bending entirely. Therefore, the plate thickness requirements in 9.1 are intended to provide an adequate level of accuracy in the compression test results so as to conform to the limits of practicality of the testing laboratory.

9.2 *Installing the Prism in the Test Machine*—Wipe clean the bearing faces of the platens, the bearing plates, and the test specimen. Place the test specimen on the lower platen or bearing plate. Align both centroidal axes of the specimen with the center of thrust of the machine. As the spherically seated upper platen or plate is brought to bear on the specimen, rotate the movable portion of the upper platen gently by hand so that uniform seating is obtained.

9.3 *Loading*—Apply the load to the prism up to one-half of the expected total load at any convenient rate. Apply the remaining load at a uniform rate in not less than 1 nor more than 2 min. If the mode of failure cannot be determined once the maximum load is reached, continue loading the specimen until the mode of failure is identifiable. Record the maximum load and note the mode of failure.

9.4 *Observations*—Describe the mode of failure as fully as possible or illustrate, or both, crack patterns and spalling on a sketch or photograph. Note whether failure occurred on one side or one end of the prism prior to fracture of the opposing side or end of the prism. Identify mode of failure using Fig. 4.

10. Calculation

10.1 Calculate test results as follows:

10.1.1 *Net Cross-Sectional Area*—Take the net cross-sectional area of ungrouted prisms as the net cross-sectional area of masonry units, which are cut as in the prism, determined by measurement or from a representative sample of units that are cut as in the prism, in accordance with Test

ASTM C 1314 – 03a

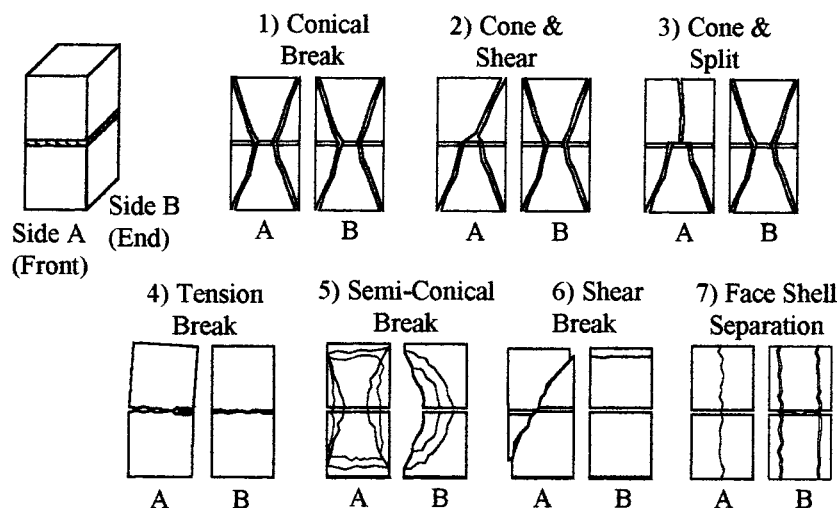

FIG. 4 Sketches of Mode of Failure

Methods C 140 for concrete masonry and with Test Methods C 67 for clay masonry. Determine net cross-sectional area of fully grouted prisms by multiplying the length and width of the prism (see 8.1).

NOTE 5—Net area of concrete masonry units other than 100 % solid units is determined by Test Methods C 140. Net area determined by Test Methods C 140 is usually slightly different from the minimum net cross-sectional area.

10.1.1.1 Consider clay masonry units whose net cross-sectional area is at least 75 % of the gross cross-sectional area as 100 % solid.

10.1.2 *Masonry Prism Strength*—Calculate each masonry prism strength by dividing each prism’s maximum compressive load sustained by the net cross-sectional area of that prism, and express the result to the nearest 10 psi (69 kPa).

10.1.2.1 Where sets of grouted and ungrouted prisms are tested, calculate the masonry prism strength separately for the grouted set and the ungrouted set.

10.1.2.2 Where a set of prisms is tested for each wythe of a multi-wythe wall, calculate the masonry prism strength for each wythe.

10.1.3 Compressive Strength of Masonry:

10.1.3.1 Calculate the h_p/t_p ratio for each prism using the height and the least lateral dimension of that prism. Determine the correction factor from Table 1. If a prism’s height to thickness ratio lies between the h_p/t_p values of Table 1, determine the corresponding correction factor by linear interpolation between the given values.

10.1.3.2 Multiply the masonry prism strength by the correction factor for the respective prism.

10.1.3.3 Calculate the compressive strength of masonry, f_{mr} , for each set of prisms by averaging the values obtained.

11. Report

11.1 Report the following information:

11.1.1 Name of testing laboratory.

11.1.2 Designation of each prism tested and description of prism including width, height, and length dimensions; h_p/t_p ratio; mortar type; and grout and masonry unit used in the construction.

11.1.3 The maximum and minimum temperature experienced by the prisms during the first 48 h after construction and grouting.

11.1.4 Age of prism at time of test.

11.1.5 Maximum compressive load sustained by each prism in pounds force or newtons.

11.1.6 Net cross-sectional area of each prism in square inches or square millimetres, and method used to calculate area.

11.1.7 Test observations for each prism in accordance with 9.4.

11.1.7.1 Mode of failure (see Fig. 4)

11.1.8 Compression machine spherical head diameter (or projected diameter if applicable), upper bearing plate thickness requirement based on size of tested specimen, and thickness of upper bearing plate used.

11.1.9 Compression machine lower platen dimensions, lower bearing plate thickness requirement based on size of tested specimen, and thickness of lower bearing plate used.

11.1.10 Compressive strength of each prism calculated to the nearest 10 psi or 69 kPa (see 10.1.3.2).

11.1.11 Compressive strength of masonry, f_{mr} , for each set of prisms calculated to the nearest 10 psi or 69 kPa (see 10.1.3.3).

12. Precision and Bias

12.1 Due to the variety of materials and combinations of materials involved, no statement is made concerning the precision or bias of this test method. Sufficient test data for all materials and combinations of materials are not available to permit the development of precision and bias statements.

TABLE 1 Height to Thickness Correction Factors for Masonry Prism Compressive Strength

h_p/t_p^A	1.3	1.5	2.0	2.5	3.0	4.0	5.0
Correction Factor	0.75	0.86	1.0	1.04	1.07	1.15	1.22

^A h_p/t_p —Ratio of prism height to least lateral dimension of prism.

13. Keywords

13.1 compressive strength of masonry; masonry prism; masonry prism strength; specified compressive strength of masonry

ANNEX

(Mandatory Information)

A1. DETERMINING PLATE THICKNESS REQUIREMENTS FOR COMPRESSION TESTING

A1.1 *Scope*—This annex provides additional information to assist in determining the plate thickness requirements for compression testing as written in 9.1.

A1.2 *Test Equipment*—Fig. A1.1 shows the location of the referenced test equipment as used in the compression testing of masonry prisms.

A1.3 *Determining the Diameter of the Upper Platen*—As shown in Fig. A1.2, the diameter of the upper platen is considered in this test method to be equal to the maximum horizontal dimension measured across the circle created by the spherical portion of the upper platen (this measured diameter will often differ from the actual geometric diameter of the sphere based on its curvature). If the upper platen includes a non-spherical section that was manufactured integrally with the spherical head from a single piece of steel, the diameter of the upper platen is considered to be the diameter of the spherical seat on the upper surface of the upper platen plus the thickness of the non-spherical section (t_{PL}). However, the diameter of the upper platen shall not be greater than the minimum horizontal

dimension of the upper platen.

A1.4 *Distance from Edge of Platen to Furthest Corner of Test Specimen*—Determine the distance from the edge of the platen to the furthest corner of the specimen as follows:

A1.4.1 Locate the specimen's center of mass, and mark it on top of the specimen.

A1.4.2 Determine to the nearest $\frac{1}{8}$ in. (3 mm) the distance from the center of mass of the specimen to the furthest corner or edge of the test specimen. Record this distance as A .

A1.4.3 The distance from the platen to the furthest corner of the test specimen is obtained by the following equation (see Fig. A1.3):

$$d = A - \frac{D_{PL}}{2} \quad (A1.1)$$

where:

d = distance from the platen to the furthest corner of the test specimen, in. (mm), and

A = distance from the center of mass of the specimen to the furthest corner of the test specimen, in. (mm).

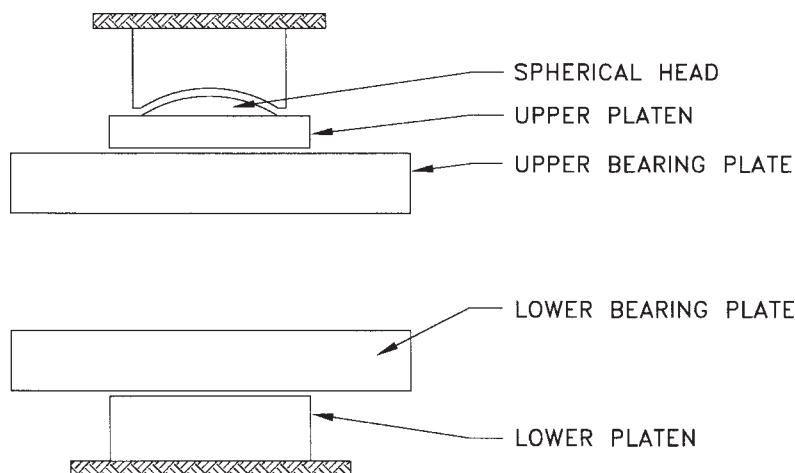
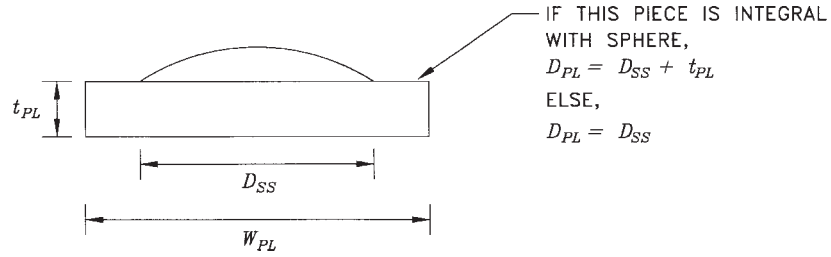

FIG. A1.1 Equipment Used for Compression Testing

ASTM C 1314 - 03a



where:

- D_{SS} = measured diameter of spherical seat,
- D_{PL} = calculated diameter of upper platen,
- W_{PL} = measured minimum width of upper platen, and
- t_{PL} = measured thickness of nonspherical section of upper platen.

FIG. A1.2 Diameter of the Upper Platen

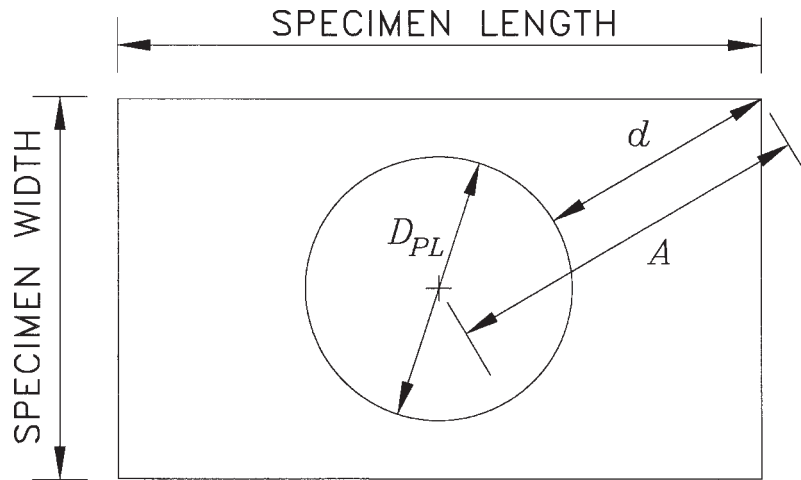

FIG. A1.3 Distance from Platen to Furthest Corner of Test Specimen

APPENDIXES

(Nonmandatory Information)

X1. SAMPLE TEST REPORT

X1.1 Fig. X1.1 is a sample test report.

X2. GUIDANCE ON THE USE OF C 1314 FOR RESEARCH PURPOSES

X2.1 *Scope*—Test Method C 1314 was developed as a tool to verify the properties of the materials being used in construction to determine compliance with specified compressive strengths. The Significance and Use section also suggests that this method can be used as a basis for research purposes. This appendix provides additional guidance on aspects of materials, construction and analysis to be considered by the researcher as well as information that should be considered for inclusion in a research report. The following suggestions are for guidance only and should not be considered comprehensive nor applicable to all projects.

X2.2 *Masonry Materials*—The researcher should select materials that are relevant to the purpose of the research. The research should control those material properties whose effects are being studied, and should permit representative variation of other material properties. Use the following information to select materials and to determine properties of those materials used in the construction of the masonry prisms.

X2.2.1 *Masonry Units*

Practice E 105 includes random sampling procedures as an alternative sampling method to those of individual product test methods. Evaluation of the following unit properties is recommended as a minimum.

X2.2.1.1 *Clay Masonry Units*

Determine and report the dimensions, percent void area, compressive strength, initial rate of absorption, and 5-hour and 24-hour absorption in accordance with Test Methods C 67. Compare results to applicable unit specification for classification and compliance.

X2.2.1.2 *Concrete Masonry Units*

Determine and report the dimensions, net area, absorption, density and compressive strength in accordance with Test Methods C 140. Compare results to applicable unit specification for classification and compliance.

X2.2.2 *Mortar*

Unless otherwise required, use one of the types of mortar specified in Specification C 270 and unless otherwise required, use the proportion specification of Specification C 270. If, however, the property specification of Specification C 270 is used, establish mix proportions by determining physical properties of the laboratory mixed mortar at specified flow in accordance with procedures of Specification C 270. Prior to mixing mortar for construction of test specimens, regardless of whether the proportion or property specification is used, verify that the specified or established proportions are used and

controlled. Report the actual constituents and proportions used. Unless mortar consistency is a variable being studied, mix mortar to typical construction consistency. Report how, when, and from where mortar is sampled. As a minimum, determine and report the following mortar properties.

X2.2.2.1 *Consistency*

Test Method C 780, Annex A1

X2.2.2.2 *Air Content*

Test Method C 780, Annex A5

X2.2.2.3 *Compressive Strength*

Test Method C 780, Annex A6

X2.2.3 *Mortar Aggregates*

X2.2.3.1 *Sand Moisture Content*

Prior to batching, determine and report the moisture content of the sand. Calculate the amount of water included in the sand. If necessary, adjust sand weights to achieve desired volume proportions of materials. Report any adjustments that were made to sand weights to account for sand moisture.

X2.2.3.2 *Sieve Analysis*

Determine and report the gradation of the sand using Test Method C 136. Compare gradation to requirements of Specification C 144.

X2.2.4 *Grout*

Unless otherwise required, use coarse or fine grout in accordance with Specification C 476 and unless otherwise required use the proportion method of Specification C 476. Alternatively, use the strength requirement method of specifying the grout in accordance with Specification C 476 if a target grout strength is desired. If needed, prepare trial mixes to determine the proportions of materials needed to produce the desired grout strength. Prior to mixing grout for construction of test specimens, regardless of whether the proportion or strength specification is used, verify that the specified proportions are used and controlled. Report the actual constituents and proportions used. Unless grout consistency is a variable being studied, mix grout to a typical construction consistency, 8 to 11 inch (203 to 279 mm) slump. As a minimum, determine and report the following properties:

X2.2.4.1 *Slump*

Test Method C 143

X2.2.4.2 *Compressive Strength*

Test Method C 1019

X2.3 Handling and Curing

X2.3.1 Construct and store the prisms as required in this standard. If curing methods are not a variable of the research,



when prisms are not curing in plastic bags in accordance with this standard, store the prisms in an area with a relative humidity of 30 to 70 % that is free of drafts.

X2.3.2 Monitor and report the temperature and relative humidity of the curing environment throughout the curing time period.

X2.4 Testing Multiple Wythe Prisms—Apply suitable sensitive gages transversely across the collar joint at the midheight of the specimen to detect the formation of cracks in the plane of the collar joint. (Bonded wire gages have been found to be suitable for these purposes.) The measurements of transverse strain across collar joints in double or multi-wythe walls are essential to determine whether a plane of weakness exists along a continuous vertical joint, such as a collar joint, that may develop significant tensile strains indicating potential premature cracking. Report measured strains.

X2.5 Determination of Modulus of Elasticity—When required, determine the chord modulus in accordance with Test Method E 111. Follow the designated method to the greatest extent possible. Plot the values and determine and report the chord modulus of elasticity for suitable values of stress and strain using end points of 0.05 and 0.33 of the maximum compressive stress of each prism. In the case of double-wythe walls, also plot the compressive stress versus the transverse strain measured across the collar joint.

SUMMARY OF CHANGES

Committee C15 has identified the location of selected changes to this standard since C 1314–03 was published.

- (1) Throughout the standard, the phrase “type of fracture” was replaced with “mode of failure”.
- (2) Detailed provisions for capping prisms for compression testing were removed from 8.2 and replaced with a reference to a new standard practice for capping, Practice C 1552. This new

- practice was also added to 2.1 as a referenced document.
- (3) To provide guidance on the use of the standard for research purposes, information was added to Section 2 and 4.2.1. Appendix X2 was added.

Committee C15 has identified the location of selected changes to this standard since C 1314–02a was published.

- (1) Changes were made to the following sections to replace permissive language with mandatory language: 4.2, 5.5, 8.2, 9.1, and A1.3.

- (2) Fig. X1.1 Sample Report was modified to provide for reporting type of fracture.

ASTM International takes no position respecting the validity of any patent rights asserted in connection with any item mentioned in this standard. Users of this standard are expressly advised that determination of the validity of any such patent rights, and the risk of infringement of such rights, are entirely their own responsibility.

This standard is subject to revision at any time by the responsible technical committee and must be reviewed every five years and if not revised, either reapproved or withdrawn. Your comments are invited either for revision of this standard or for additional standards and should be addressed to ASTM International Headquarters. Your comments will receive careful consideration at a meeting of the responsible technical committee, which you may attend. If you feel that your comments have not received a fair hearing you should make your views known to the ASTM Committee on Standards, at the address shown below.

This standard is copyrighted by ASTM International, 100 Barr Harbor Drive, PO Box C700, West Conshohocken, PA 19428-2959, United States. Individual reprints (single or multiple copies) of this standard may be obtained by contacting ASTM at the above address or at 610-832-9585 (phone), 610-832-9555 (fax), or service@astm.org (e-mail); or through the ASTM website (www.astm.org).