



Designation: C 1357 – 02

Standard Test Methods for Evaluating Masonry Bond Strength¹

This standard is issued under the fixed designation C 1357; the number immediately following the designation indicates the year of original adoption or, in the case of revision, the year of last revision. A number in parentheses indicates the year of last reapproval. A superscript epsilon (ϵ) indicates an editorial change since the last revision or reapproval.

INTRODUCTION

Bond strength between mortar and masonry units is an important physical property of masonry. Increased bond strength provides greater resistance to loads and to cracking. Bond strength therefore influences structural integrity and serviceability.

1. Scope

1.1 These test methods cover the evaluation of flexural bond strength, normal to the bed joints, of masonry built of manufactured masonry units, as determined in accordance with Test Method C 1072. Sampling and testing procedures are referenced, and terms are defined. Two different test methods are specified, each for a different purpose:

1.1.1 The first test method is the “Test Method for Laboratory-Prepared Specimens.” Its purpose is to compare the bond strengths (under the given conditions) of masonry mortars. It could be used, for example, to check the quality of mortar products after production, or to indicate the bond strength (under the given conditions) of a mortar product without requiring the product to be tested in combination with many different units. It is not intended to represent field conditions. It uses standard concrete masonry units. Mortars are batched by weight equivalents of volume proportions and are mixed to a prescribed flow. Prisms are constructed using a jig and are bag-cured.

NOTE 1—Standard fired clay masonry units are under development but are not now available. When their development is complete, they will be incorporated into these test methods.

1.1.2 The second test method is the “Test Method for Field-Prepared Specimens.” Its purpose is to evaluate the bond strength (under the given conditions) of a particular unit-mortar combination, either for preconstruction evaluation of materials or for quality control purposes during construction. Mortars are batched conventionally, and the flow is not prescribed. Prisms are constructed conventionally (no jig) and are bag-cured.

¹ These test methods are under the jurisdiction of ASTM Committee C15 on Manufactured Masonry Units and are the direct responsibility of Subcommittee C15.05 on Masonry Assemblies.

Current edition approved June 10, 2002. Published July 2002. Originally published as C 1357–96. Last previous edition C 1357–98a.

1.1.3 The two test methods are not consistent, nor are they intended to be. They are intended to be used for two different purposes. To make this clear, the two methods are presented separately.

1.1.4 Appendix X1 suggests two possible criteria for assessing the bond strength values obtained using these test methods. These possible evaluation criteria are given for illustration only and are not mandatory.

1.2 The values stated in inch-pound units are to be regarded as the standard. The values given in parentheses are for information only.

1.3 *This standard does not purport to address all of the safety concerns, if any, associated with its use. It is the responsibility of the user of this standard to establish appropriate safety and health practices and determine the applicability of regulatory limitations prior to use.*

2. Referenced Documents

2.1 ASTM Standards:

C 67 Test Methods of Sampling and Testing Brick and Structural Clay Tile²

C 140 Test Methods of Sampling and Testing Concrete Masonry Units²

C 230 Specification for Flow Table for Use in Tests of Hydraulic Cement³

C 270 Specification for Mortar for Unit Masonry²

C 780 Test Method for Preconstruction and Construction Evaluation of Mortars for Plain and Reinforced Unit Masonry²

C 1072 Test Method for Measurement of Masonry Flexural Bond Strength²

C 1437 Test Method for Flow of Hydraulic Cement Mortar³

2.2 Other Documents:

² *Annual Book of ASTM Standards*, Vol 04.05.

³ *Annual Book of ASTM Standards*, Vol 04.01.

Building Code Requirements for Masonry Structures (ACI 530-99/ASCE 5-99/TMS 402-99)⁴
NBS Handbook 91⁵

3. Terminology

3.1 Definitions:

3.1.1 *lot, n*—material of a given quantity of a single type, grade, class, and brand and practically of the same nominal size, color range, texture, and composition produced by a single source by virtually the same process and under essentially the same conditions.

3.1.2 *sample, n*—a number of specimens selected at random from a lot in which every specimen has an equal chance of being selected in every trial.

3.1.2.1 *Discussion*—It is virtually impossible to select a sample at random by exercise of human judgment alone. To avoid bias, it is necessary to select a random sample using an artificial or mechanical device such as a table of random numbers or a random number generator.

3.1.3 *specimen, n*—an individual piece of randomly selected material in a sample.

TEST METHOD FOR LABORATORY-PREPARED SPECIMENS

4. Summary of Test Method

4.1 This test method is for evaluating the flexural bond strength (under the given conditions) of masonry built of standard masonry units, as determined in accordance with Test Method C 1072. It uses standard concrete masonry units. Mortars are batched by weight equivalents of volume proportions and are mixed to a prescribed flow. Prisms are constructed using a jig and are bag-cured.

5. Significance and Use

5.1 This test method is intended for use in comparing the bond strengths (under the given conditions) of masonry mortars, as determined in accordance with Test Method C 1072.

5.2 This test method could be used, for example, to check one aspect of the quality of mortar products after production, or to indicate the bond potential of a mortar product without requiring the product to be tested in combination with many different units.

5.3 This test method uses controlled conditions of fabrication and curing that are not intended to represent field conditions.

5.4 This test method uses standard concrete masonry units. Mortars are batched by weight equivalents of volume proportions and are mixed to a prescribed flow. Prisms are constructed using a jig and are bag-cured.

5.5 Flexural bond strength determined by this test method shall not be interpreted as the flexural bond strength of a wall (because standard units are not used for wall construction), nor shall it be interpreted as an indication of extent of bond for purposes of water permeability evaluation.

6. Apparatus

6.1 Prism Fabrication Jig, as described in Annex A2 and shown in Fig. A2.1.

6.2 Mortar Joint Template, as described in Annex A2 and shown in Fig. A2.2.

6.3 Drop Hammer, as described in Annex A2 and shown in Fig. A2.3

6.4 Mechanical Paddle-Type Mortar Mixer, of no less than 0.6 ft³(18L) capacity.

6.5 Flow Table, Flow Mold, and Caliper, conforming to the requirements of Specification C 230.

6.6 Cone Penetrometer, Unit Measure, Straightedge, Spatula, Tapping Stick, and Spoon, conforming to the requirements of Test Method C 780.

6.7 Bond Strength Test Apparatus, conforming to the requirements of Test Method C 1072.

7. Materials

7.1 Select representative samples of each lot of mortar materials. Each sample of material shall be of sufficient quantity to build a set of test prisms. Use standard concrete masonry units meeting the requirements of Annex A1.

7.2 Mortar materials (including water) shall be at an equilibrium temperature with laboratory air (see Section 8).

8. Temperature and Humidity

8.1 Maintain the temperature of laboratory air in the vicinity of mixing of mortar, fabrication of specimens, curing, and testing of specimens at $24 \pm 9^{\circ}\text{C}$ ($75 \pm 16^{\circ}\text{F}$)

8.2 Maintain the relative humidity of laboratory air in the vicinity of mixing of mortar, fabrication of specimens, and testing of specimens between 30 and 80 %.

9. Procedure

9.1 Fabricate a set of test prisms (any convenient number of prisms) containing a total of not less than 15 nor more than 30 mortar joints. Each prism shall have no more than 5 joints.

9.1.1 Proportion mortar materials by weights equivalent to volume proportions to be used in prism construction. Use unit weights for individual materials as given in Specification C 270. Sand shall be permitted to be used in a damp loose condition, provided that moisture content of sand is determined with reference to the oven-dried condition and batch proportions are adjusted accordingly. Record weight of ingredients (including water) added to the batch of mortar.

9.1.2 Mix mortar in a mechanical paddle-type mortar mixer. Time periods referenced below are measured from when water and cementitious materials are combined.

9.1.2.1 For standard concrete masonry units, add an estimated amount of water to the mortar to achieve a flow of 127 ± 3 determined in accordance with Test Method C 1437. Mix mortar for three minutes and determine flow. Once flow is recorded, return the material used to measure flow to the mixer. If the flow is 127 ± 3 , continue mixing the batch for an additional two minutes. If the flow is less than 124, add water to the batch, mix for one minute, and determine flow. Once flow is recorded, return the material used to measure flow to the mixer. If the flow is 127 ± 3 , continue mixing the batch for one minute.

⁴ Available from Masonry Standards Joint Committee.

⁵ Natrella, M. G., *Experimental Statistics*, National Bureau of Standards Handbook 91, U.S. Government Printing Office, August 1, 1963, pp. 2–14.

9.1.2.2 If after the one-time addition of water the flow is not 127 ± 3 , discard the batch.

9.1.2.3 If the measured flow exceeds 130 at any time, discard the batch.

9.1.3 Immediately after mixing the mortar, determine its initial cone penetration in accordance with Test Method C 780. Determine the cone penetration of the mortar every 15 ± 5 minutes. If the cone penetration is less than 80 % of its initial value, discard the remaining portion of the mortar without constructing additional mortar joints.

9.1.4 Use standard concrete masonry units as defined in Annex A1. Clean the bed surface of units of dirt, loose sand, or other contaminants.

9.1.5 Fabricate prism specimens as described in Annex A2.

9.1.6 Cure prism specimens in accordance with Annex A2.

9.2 Conduct bond-wrench tests on prism specimens.

9.2.1 Test the prisms in the same facility where they were built.

9.2.2 Test masonry prisms in accordance with the requirements of Test Method C 1072 except as otherwise provided in this test method.

NOTE 2—When test ages other than 28 days are specified, the general relationship between the strength at the specified test age and that at 28 days is generally established by test. That relationship may vary with different materials and curing conditions.

10. Report

10.1 Identify mortar materials and units tested, including as applicable the manufacturer's name, brand name, type, grade, source of sample, date sampled, and date tested.

10.2 List unit dimensions, number of joints per prism, and number of prisms per set of specimens.

10.3 Include the following in the report:

10.3.1 Weight of ingredients (including water) added to the batch of mortar.

10.3.2 Flow or cone penetrometer reading of mortar used to construct prisms.

10.3.3 Flexural bond strength test results for each joint of the test specimens. Mean, standard deviation, and test age for each set of test specimens.

11. Precision and Bias

11.1 *Precision*—Published data are not available for within-laboratory variability of this test method. Published data (Hedstrom,⁶ Melander⁷) obtained under conditions almost identical with those of this test method show within-batch coefficients of variation varying between 10 % and 25 % for 30-joint samples of selected portland cement-lime mortars and masonry cement mortars. Because only one sample of each mortar was tested in each laboratory, sufficient data are not

available to establish repeatability for this test method. Inter-laboratory testing is now planned to determine the reproducibility of this test method. It is the intent of this committee to develop precision values within 5 years from the date of issuance of this test method.

11.2 *Bias*—No information can be presented on the bias of this test method because no test having an accepted reference value is available.

TEST METHOD FOR FIELD-PREPARED SPECIMENS

12. Summary of Test Method

12.1 This test method is for evaluating the flexural bond strength (under the given conditions) of masonry built of conventional masonry units, as determined in accordance with Test Method C 1072. Mortars are batched conventionally, and their flow is not prescribed. Prisms are constructed conventionally (no jig) and are bag-cured.

13. Significance and Use

13.1 This test method is intended for evaluation of flexural bond strength (under the given conditions) between mortar and units, as determined in accordance with Test Method C 1072.

13.2 The purpose of this test method is to evaluate the bond strength (under the given conditions) of a particular unit-mortar combination, either for preconstruction evaluation of materials or for quality control purposes during construction. Preconstruction field tests may be used to provide information on the potential performance of a mortar-unit combination under field conditions of fabrication and workmanship (but not curing). Construction field tests may be used as a quality control measure to ensure that performance criteria established in preconstruction tests are being met.

13.3 Flexural bond strength determined by this test method shall not be interpreted as the flexural bond strength of a wall constructed of the same material, nor shall it be interpreted as an indication of extent of bond for purposes of water permeability evaluation. However, if effects of construction conditions, specimen size, workmanship, and curing conditions are taken into account, the results may be used to estimate the flexural strength of a wall.

14. Sampling

14.1 Select representative samples of each lot of masonry materials intended for use in construction. Each sample of material shall be of sufficient quantity to build a set of test prisms. A lot of each material shall consist of not less than the following quantities:

14.1.1 4000 of each type of masonry unit,

14.1.2 15 bags of each type of cement (or the equivalent bulk quantity),

14.1.3 15 bags of lime (or the equivalent bulk quantity),

14.1.4 3 yd³ of sand, and

14.1.5 If mortar is delivered in bulk, 3 yd³ of mortar.

15. Procedure

15.1 Prepare and mix mortar in accordance with the construction contract specifications. If no construction contract specifications exist, use the mortar preparation procedures of

⁶ Hedstrom, E. G., Tarhini, K. M., Thomas, R. D., Dubovoy, V. S., Klingner, R. E., and Cook, R. A., "Flexural Bond Strength of Concrete Masonry Prisms Using Portland Cement and Hydrated Lime Mortars," *Masonry Society Journal*, Vol 9, No. 2, February 1991.

⁷ Melander, J. M., Ghosh, S. K., Dubovoy, V. S., Hedstrom, E. G., and Klingner, R. E., "Flexural Bond Strength of Concrete Masonry Prisms Using Masonry Cement Mortars," *Masonry: Design and Construction, Problems and Repair*; ASTM STP 1180, ASTM, 1993.

Test Method C 780, modifying them as appropriate when proprietary materials are added to the mortar or when pre-batched materials are used. Use sufficient water to achieve optimum workability.

NOTE 3—Workable consistency of mortar for concrete masonry construction generally requires an initial cone penetration reading of 55 ± 5 mm or a flow of 125 ± 5 %. Workable consistency of mortar for clay masonry construction generally requires an initial cone penetration reading of 65 ± 5 mm or a flow of 135 ± 5 %. Optimum consistency for a specific mortar-unit combination may differ from these values.

15.2 Fabricate a set of any convenient number of prisms, containing a total of at least 15 mortar joints. Do not fabricate more prism specimens than can be constructed within 30 min. When conducting construction field tests for quality control, build one set of test prisms for each 5000 ft² of masonry in the structure.

15.2.1 Sample and test mortar in accordance with Test Method C 780 to determine initial consistency by cone penetrometer and air content.

15.2.2 Clean the bed surface of the units of dirt, loose sand, or other contaminants. Sample and test clay units in accordance with Test Methods C 67 to determine initial rate of absorption (Field Test).

15.2.3 Fabricate prism specimens in accordance with Test Method C 1072. Construct specimens in an open moisture-tight bag large enough to contain the completed prism (see Annex A2). After fabrication, draw and seal the bag around the specimen.

15.2.4 Maintain a record of daily high and low temperatures in area of specimens.

15.2.5 Do not disturb or move specimens for the first 48 h after construction. Keep specimens in the moisture-tight bags. Keep specimens at essentially the same temperatures as those experienced by the masonry that the specimens are intended to represent. At 24 ± 4 h prior to test age, remove bag and place specimens in laboratory air with a temperature of $75 \pm 15^\circ\text{F}$ ($24 \pm 8^\circ\text{C}$) and a relative humidity between 20 % and 80 %.

NOTE 4—For laboratory testing, test the prisms in the same facility where they were built. For field testing, carefully package prisms there and transport them to a laboratory for testing.

15.2.6 If specimens are transported for testing, strap them tightly first. Prepare plywood boards at least $\frac{3}{4}$ -in. thick, cut to the size of the bed area of the unit. Place these boards under the bottom unit and on the top unit of the prism prior to strapping. During transport, cushion the specimens from vibration and from direct contact with each other.

15.2.7 Test specimens at an age of 28 days unless otherwise specified. Do not test specimens at an age of less than 3 days.

15.3 *Testing Specimens*—Test masonry prisms in accordance with the requirements of Test Method C 1072 except as otherwise provided in this test method.

NOTE 5—When test ages other than 28 days are specified, the general relationship between the strength at the specified test age and that at 28 days is generally established by test. That relationship may vary with different materials and curing conditions.

16. Report

16.1 Identify mortar materials and units tested, including as applicable the manufacturer's name, brand name, type, grade, source of sample, date sampled, and date tested.

16.2 List number of prisms per set of specimens, number of joints per prism, unit dimensions, and joint thicknesses.

16.3 Include the following in the report of preconstruction evaluation and construction field test results:

16.3.1 Volume proportions of mortar ingredients used in test mortar batch. Note whether mortar was prepared under the proportion or the property specification requirements of Specification C 270.

16.3.2 Whether report is of preconstruction evaluation test or construction field tests. If field tests, identify building area represented by set of specimens.

16.3.3 Length of mixing time, time at which mixing was completed, and time at which specimen fabrication was completed.

16.3.4 Initial consistency as determined by cone penetrometer, mortar water content, mortar aggregate ratio, air content, and compressive strength determined in accordance with Test Method C 780.

16.3.5 Initial rate of absorption (Field Test) of fired clay masonry units, as determined in accordance with Test Methods C 67.

16.3.6 Ambient temperature and humidity at time specimens were fabricated.

16.3.7 Daily high and low temperatures in area where specimens were stored for curing.

16.3.8 Date and time when curing bags were removed from specimens.

16.3.9 Description of strapping procedure, if applicable.

16.3.10 Date and time specimens were delivered to laboratory, if applicable.

16.3.11 Condition of specimens as received from transport, if applicable.

16.3.12 Length of time specimens were exposed to laboratory air prior to testing.

16.3.13 Individual flexural bond strength test results for each joint of the test specimens. Mean, standard deviation, and test age for each set of test specimens.

17. Precision and Bias

17.1 *Precision*—Because this test method can be applied to many different combinations of units and mortar, and because workmanship is not controlled in fabricating field-prepared specimens, it is not possible to establish repeatability and reproducibility values that would be universally correct.

17.2 *Bias*—No information can be presented on the bias of this test method because no test having an accepted reference value is available.

18. Keywords

18.1 flexural bond strength; masonry

ANNEXES

(Mandatory Information)

A1. STANDARD CONCRETE MASONRY UNITS⁸

A1.1 Standard concrete masonry units are special concrete units selected for the purpose of determining the flexural bond strength properties of mortars. The standard concrete masonry unit shall conform to the following requirements:

A1.1.1 Dimensions of units shall be 3⁵/₈ in. (92 mm) wide by 2¹/₄ in. (57 mm) high by 7⁵/₈ in. (194 mm) long within a tolerance of ±¹/₈ in. (3 mm). Units shall be 100 % solid.

A1.1.2 The unit material shall be concrete masonry manufactured with the following material proportions by volume: 1 part portland cement to 8 parts aggregate.

A1.1.3 Aggregate used in the manufacture of the unit shall be as follows:

Gradation	Bulk Specific Gravity 2.6 to 2.7	Percent Retained by Weight
3/8-in. sieve		0
No. 4 sieve		0 to 5
No. 8 sieve		20 to 30

⁸ The sole source of supply of the apparatus known to the committee at this time is National Concrete Masonry Association (NCMA), 2302 Horse Pen Road, Herndon, VA 22071-3499. If you are aware of alternative suppliers, please provide this information to ASTM Headquarters. Your comments will receive careful consideration at a meeting of the responsible technical committee, which you may attend.

No. 16 sieve	20 to 30
No. 30 sieve	15 to 25
No. 50 sieve	5 to 15
No. 100 sieve	5 to 10
Pan	5 to 10

A1.1.4 Density of the unit shall be 125 to 135 lb/ft³ (2000 to 2160 kg/m³).

A1.1.5 During manufacturing of the standard masonry unit, prevent contamination of the surfaces of the unit by mold-release agent.

A1.1.6 After manufacturing, cure units for 10 to 20 h at a relative humidity of 100 %, a temperature of 140 ± 10°F (160 ± 5°C), and atmospheric pressure. Continue curing in a roofed structure under ambient temperature and relative humidity for at least 28 days. After curing, stack the units in the cube at least 1/4 in. (6 mm) apart in each horizontal layer to allow air to circulate during drying.

A1.1.7 Upon delivery, protect the units from outside contamination. Wet units only to meet the requirements of A1.1.8. Do not surface-treat the units prior to or during prism fabrication.

A1.1.8 When the prisms are fabricated, units shall have a moisture content of between 25 % and 35 % of total absorption, as determined in accordance with Test Methods C 140.

A2. FABRICATION OF LABORATORY-PREPARED TEST SPECIMENS

A2.1 Fabricate the test specimens as follows:

A2.1.1 Each prism shall be built in an opened moisture-tight bag that is large enough to enclose and seal the completed prism. Set the first unit of each prism on a 1/2-in. (12-mm) plywood pallet in an alignment jig, as shown in Fig. A2.1.

NOTE A2.1—The purpose of the alignment jig is to align the prism perpendicular to the surface on which the prism is constructed, to within a tolerance of ± 5 degrees in each direction (length and width of the prism). A sample alignment jig, constructed of steel plate and using flat-head machine screws for adjustment, is shown in Fig. A2.1. That jig has a base that is L-shaped rather than rectangular, thereby permitting the jig to sit beside the prism rather than under it, so that the jig can be moved away from the prism immediately after construction. Other types of jigs of other materials are acceptable provided that they align the prism and provided that the samples can be left undisturbed as specified in A2.1.8. With some types of jigs, it may be necessary to adjust the elevation of the base of the prism. This can be done with blocks about as big as the bed face of the units and made of any convenient material that will maintain uniformity of thickness when wet. Plywood blocks 1/2 in. (13 mm) thick are satisfactory for this purpose; other materials are acceptable.

A2.1.2 Place the mortar template shown in Fig. A2.2 on the unit so that the mortar bed depth prior to compaction is 1/2 in. (12 mm). Place the mortar in the template, and strike off excess mortar with a straight edge.

A2.1.3 Remove the template, and immediately place the next unit on the mortar bed in contact with the three machine screws used to align that course, using a bulls-eye level to ensure uniform initial contact of the unit surface and bed mortar. Carefully position the drop hammer shown in Fig. A2.3 on top of the unit, and drop its 4-lb (1.8-kg) steel rod, round end down, once from a height of 1.5 in. (38 mm).

NOTE A2.2—The purpose of the drop hammer is to deliver a prescribed impact to the current topmost unit of the prism. The drop hammer shown in Fig. A2.3 consists of a plastic tube fixed to a plywood base. A cylindrical steel rod is allowed to drop inside the tube, striking the base. The purpose of the tube is to guide the steel rod and also to permit the operator to hold the drop hammer on top of the prism during this operation. Provided that those purposes are achieved, other designs and materials are permitted for the drop hammer.

A2.1.4 Repeat the steps given in A2.1.2 and A2.1.3 until the prisms are complete.

A2.1.5 Joints shall be cut flush after the prism is completely built. The joints shall not be tooled.

A2.1.6 Identify all test specimens using a water-resistant marker.

A2.1.7 Draw and seal the moisture-tight bag around the prism.

A2.1.8 Do not disturb the specimens for at least 24 h.

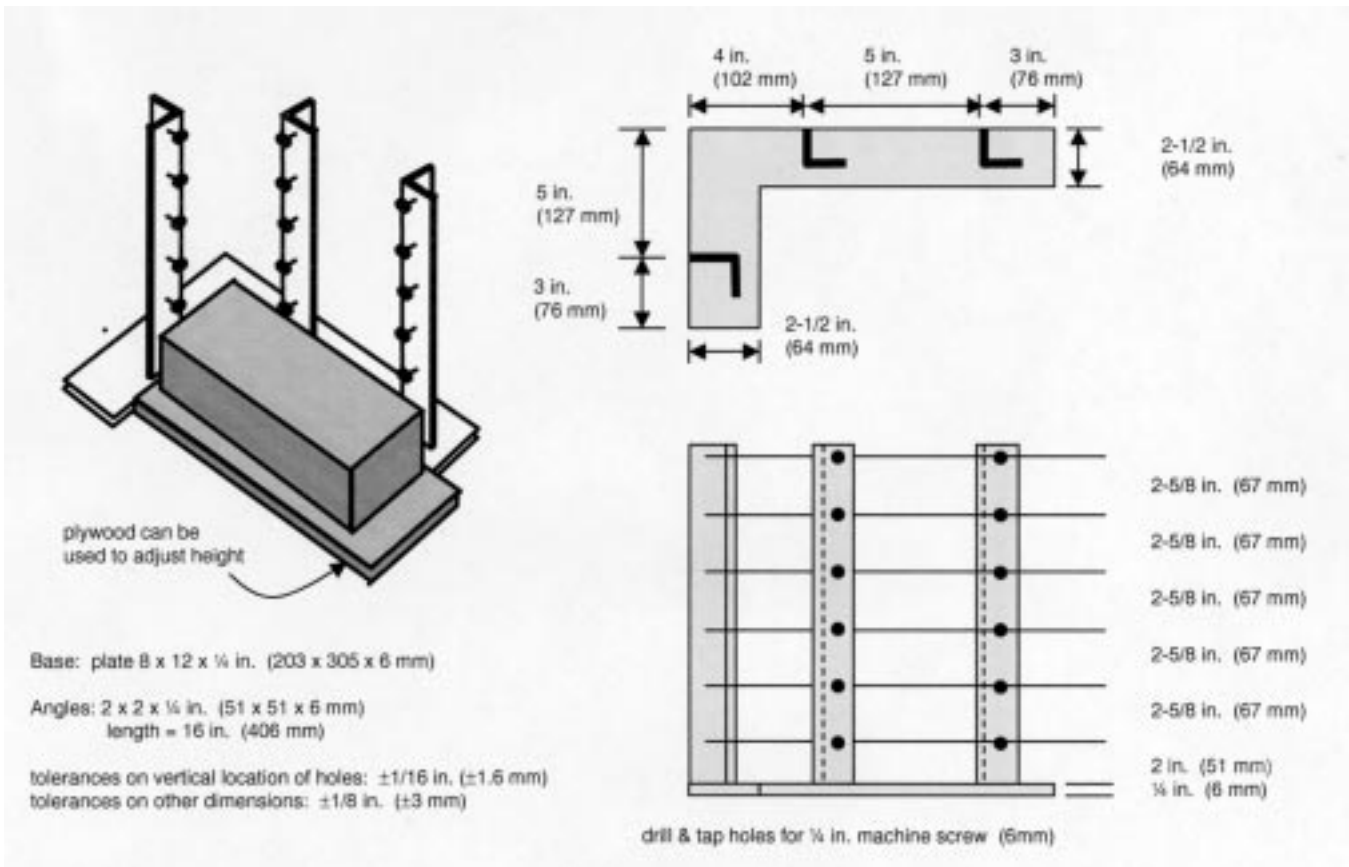

FIG. A2.1 Schematic of Alignment Jig Used in Prism Construction (refer to Annex A2 for required dimensions and materials)

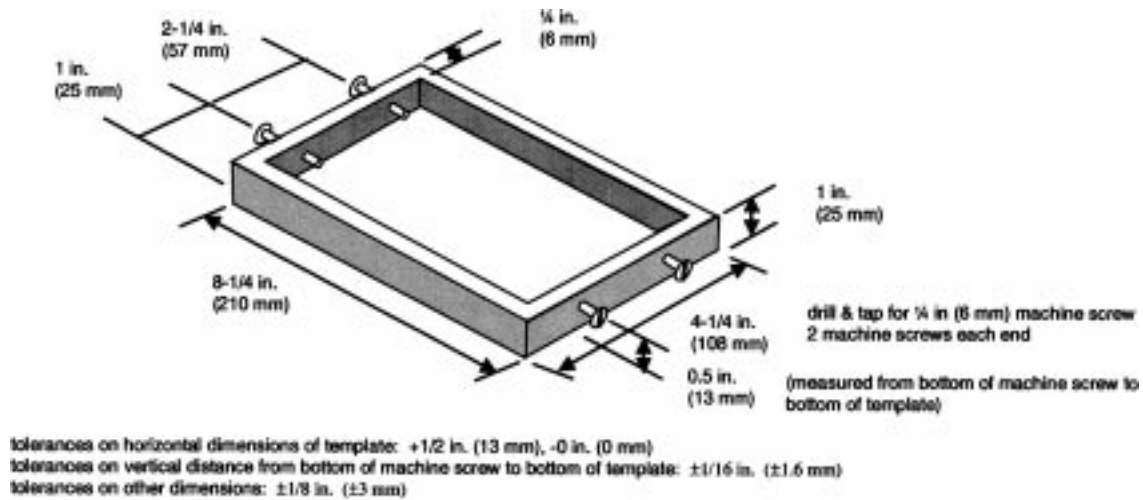

FIG. A2.2 Schematic of Mortar Joint Template Used in Prism Construction (refer to Annex A2 for required dimensions and materials)

A2.1.9 Cure all prisms for 28 days unless otherwise required.

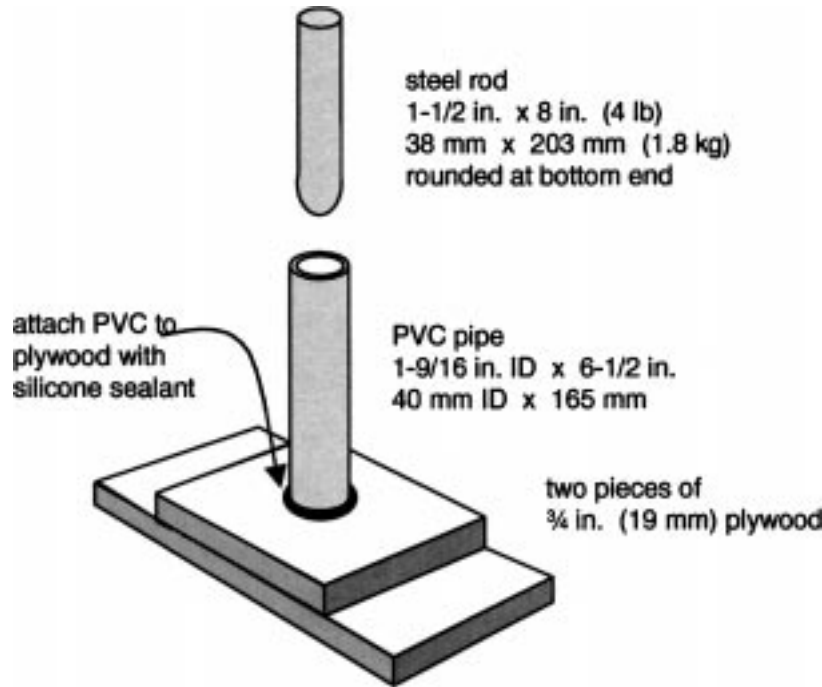

FIG. A2.3 Schematic of 4-lb Drop Hammer Used in Prism Construction (refer to Annex A2 for required dimensions and materials)

APPENDIX

(Nonmandatory Information)

X1. POSSIBLE CRITERIA FOR EVALUATING TEST RESULTS

X1.1 Introduction

X1.1.1 This standard is a test method only. Its mode of application is left to the discretion of the user. The purpose of Appendix X1 is to suggest two possible criteria for evaluating the results obtained from these test methods. These criteria are included for illustrative purposes only and are not mandatory.

X1.1.2 Many criteria are available for evaluating test results. One simple criterion would be to require that the minimum value be not less than some target value. Another would be to require that the average value be not less than some target value. However, each of these simple criteria has the disadvantage of being insensitive to the scatter of the test results. Clearly, test results with smaller scatter are more reliable; this increased reliability ought to be reflected in the evaluation criteria. For this purpose, two such criteria are discussed here. The first criterion uses a lower characteristic value. The second criterion uses a one-sided tolerance limit.

X1.2 Possible Acceptance Criterion Using a Lower Characteristic Value

X1.2.1 This possible criterion involves comparing a lower characteristic value of the tensile bond strength with a target value. This criterion has previously been used for statistical comparisons in the masonry industry. It is appropriate for use when so many joints are tested (usually at least 30) that the sample of joints closely approximates the entire population of

joints. Specifically, the objective of this example criterion would be to establish a lower 10 % characteristic value (also referred to as a “10 % fractile”) for the test data and to ensure that this lower characteristic value would exceed some target value.

X1.2.2 Determine and report the acceptability of the flexural bond strength of the masonry by the following calculation:

$$[X - (1.28 \times s)] \geq A \quad (X1.1)$$

where:

X = mean flexural tensile strength of masonry sample, psi (MPa),

s = standard deviation in flexural tensile strength of masonry sample, psi (MPa), and

A = target value, psi (MPa).

NOTE X1.1—The value of 1.28, excerpted from standard statistical tables, is based on the properties of the normal distribution. In such a distribution, 90 % of the values will lie above the mean minus 1.28 standard deviations.⁵

X1.2.3 If Eq X1.1 is satisfied, the masonry bond strength is acceptable. If Eq X1.1 is not satisfied, the masonry bond strength is not acceptable.

X1.3 Possible Acceptance Criterion Using One-Sided Tolerance Limits

X1.3.1 This possible criterion involves establishing a lower tolerance limit (based on the sample size) to the tensile bond

strength target value. The lower tolerance limit is selected so that a certain percentage of the time (the so-called “confidence”), no more than the desired percentage of the entire population will fall below the target value. This statistical technique is referred to as a “one-sided tolerance limit.” It is more complex than the lower characteristic value approach of X1.2. It is appropriate for use when relatively few joints are tested, and the sample of joints may not closely approximate the entire population of joints. It is also appropriate for use when the scatter of results is small, so that the required number of specimens is less than for the criterion of X1.2. Specifically, the objective of this example criterion is to establish a 90 % probability that 90 % of the masonry in the entire population will have a flexural bond strength, perpendicular to the bed joints, equaling or exceeding the target value.

X1.3.2 Determine and report the acceptability of the flexural bond strength of the masonry by the following calculation:

$$[X - (K \times s)] \geq A \quad (X1.2)$$

where:

- X = mean flexural tensile strength of masonry sample, psi (MPa),
- K = factor determined from Table X1.1,
- s = standard deviation in flexural tensile strength of masonry sample, psi (MPa), and
- A = target value.

TABLE X1.1 Factors for One-Sided Tolerance Limits for Normal Distributions

Number of Mortar Joints Tested	K
15	1.87
18	1.80
24	1.71
30	1.66
35	1.62
40	1.60
45	1.58
50	1.56

NOTE X1.2—The target value in Eq X1.2 might be the allowable stress in flexural tension perpendicular to bed joints in unreinforced masonry built with inspection, psi (MPa). If no other building code is used to select the allowable stress referred to above, the allowable stress might be that specified in ACI 530-99/ASCE 5-99/TMS 402-99. The allowable tensile stress would be that perpendicular to bed joints in unreinforced masonry built with inspection. It might also be some other value, determined by project design requirements.

NOTE X1.3—The values of K given in Table X1.1, excerpted from standard statistical tables, are obtained based on the properties of the normal distribution. These values of K correspond to a 90 % probability that 90 % of the masonry population will have a flexural tensile strength equal to or greater than the corresponding target value.⁵

X1.3.3 If Eq X1.2 is satisfied, the masonry bond strength is acceptable. If Eq X1.2 is not satisfied, the masonry bond strength is not acceptable.

ASTM International takes no position respecting the validity of any patent rights asserted in connection with any item mentioned in this standard. Users of this standard are expressly advised that determination of the validity of any such patent rights, and the risk of infringement of such rights, are entirely their own responsibility.

This standard is subject to revision at any time by the responsible technical committee and must be reviewed every five years and if not revised, either reapproved or withdrawn. Your comments are invited either for revision of this standard or for additional standards and should be addressed to ASTM International Headquarters. Your comments will receive careful consideration at a meeting of the responsible technical committee, which you may attend. If you feel that your comments have not received a fair hearing you should make your views known to the ASTM Committee on Standards, at the address shown below.

This standard is copyrighted by ASTM International, 100 Barr Harbor Drive, PO Box C700, West Conshohocken, PA 19428-2959, United States. Individual reprints (single or multiple copies) of this standard may be obtained by contacting ASTM at the above address or at 610-832-9585 (phone), 610-832-9555 (fax), or service@astm.org (e-mail); or through the ASTM website (www.astm.org).