



Designation: C 1492 – 01

Standard Specification for Concrete Roof Tile¹

This standard is issued under the fixed designation C 1492; the number immediately following the designation indicates the year of original adoption or, in the case of revision, the year of last revision. A number in parentheses indicates the year of last reapproval. A superscript epsilon (ϵ) indicates an editorial change since the last revision or reapproval.

1. Scope

1.1 This specification covers concrete tiles intended for the use as roof covering where durability and appearance are required to provide a weather-resistant surface of specified design.

1.2 Tiles are manufactured from portland cement, water, and mineral aggregates with or without the inclusion of other materials.

1.3 Tiles are shaped during manufacturing by molding, pressing, or extrusion. The shaping method can be used to describe the tile.

1.4 Other constituents, such as chemical and mineral admixtures established as suitable for use in concrete, shall conform to ASTM standard specifications where applicable, or shall be shown by tests or experience not to be detrimental to the durability of concrete.

1.5 Tiles are generally planar or undulating rectangular shapes available in a variety of cross-sectional areas profiles, shapes, sizes, surface textures, and colors.

NOTE 1—Concrete roof tiles covered by this specification are made from lightweight or normal weight aggregates, or both.

NOTE 2—When particular features are desired, such as color, surface texture for appearance, or other special features, such properties should be specified by the purchaser. However, the local sellers should be consulted as to the availability of concrete roof tile having a desired feature.

1.6 The values stated in inch-pound units are to be regarded as the standard.

2. Referenced Documents

2.1 ASTM Standards:

C 33 Specification for Concrete Aggregates²

C 67 Test Methods for Sampling and Testing Brick and Structural Clay Tile³

C 90 Specification for Loadbearing Concrete Masonry Units³

C 140 Test Methods for Sampling and Testing Concrete Masonry Units and Related Units³

C 150 Specification for Portland Cement⁴

C 260 Specification for Air-Entraining Admixtures for Concrete²

C 331 Specification for Lightweight Aggregates for Concrete Masonry Units²

C 494/C 494M Specification for Chemical Admixtures for Concrete²

C 595 Specification for Blended Hydraulic Cements⁴

C 618 Specification for Coal Fly Ash and Raw or Calcined Natural Pozzolan for Use as a Mineral Admixture in Concrete²

C 979 Specification for Pigments for Integrally Colored Concrete²

C 989 Specification for Ground Granulated Blast-Furnace Slag for Use in Concrete and Mortars²

C 1157 Performance Specification for Hydraulic Cement⁴

3. Terminology

3.1 *Definitions*—The following terms are used in connection with concrete roof tiles:

3.2 *batten lugs*—protrusions on the underside of the tile designed to engage over the upper edge of tiling battens.

3.3 *head lap*—distance of overlap measured from the uppermost course to the point that it laps over the undermost course.

3.4 *high profile tile*—tile with a rise to width ratio greater than 1:5.

3.5 *interlocking tile*—tiles with a system of ribs or grooves enabling the lateral joining of adjacent tiles in the same horizontal row, with the overlapping lock covering the underlapping lock.

3.6 *length*—maximum overall dimension of the tile measured parallel to the water course.

3.7 *low profile tile*—tile with a rise equal to or less than 1/2 in.

3.8 *medium profile tile*—tile with a rise greater than 1/2 in. and a rise-to-width ratio of less than or equal to 1:5.

3.9 *nail hole*—small opening passing partially or totally through the tile to allow the penetration of a nail or screw for the purpose of fastening the tile to a support.

3.10 *non-interlocking tile*—tiles that butt at the sides without lapping adjacent tiles.

3.11 *nose lugs*—protrusion on the underside of the nose of

¹ This specification is under the jurisdiction of ASTM Committee C15 on Manufactured Masonry Units and is the direct responsibility of Subcommittee C15.06 on Roofing Tile.

Current edition approved Jan. 10, 2001. Published March 2001.

² *Annual Book of ASTM Standards*, Vol 04.02.

³ *Annual Book of ASTM Standards*, Vol 04.05.

⁴ *Annual Book of ASTM Standards*, Vol 04.01.

 **C 1492**

each tile, contoured to fit into the main water courses of the tile immediately below, inhibiting the entry of wind-driven rain.

3.12 *profile*—contour of the top surface of the tile when viewed from the nose end.

3.13 *rise*—vertical distance from the underside of the batten lug to the highest point of the surface profile.

3.14 *side lap*—continuous longitudinal overlap of a tile on its neighbor.

3.15 *thickness*—any vertical measurement of the cross section of the tiles excluding the lapping area, nose lugs, and weather checks.

3.16 *weather checks*—protrusions below the tile designed to restrict the flow of water between two consecutive courses of tiles.

3.17 *width*—maximum overall dimension of the tile measured perpendicular to the length or water channel

3.18 *water course*—valley portion of a profiled tile along which water drains.

4. Classification

4.1 Concrete roof tiles manufactured in accordance with this specification are of the following types:

4.1.1 *Type I*—High Profile Tile.

4.1.2 *Type II*—Medium Profile Tile.

4.1.3 *Type III*—Low Profile Tile.

4.1.4 *Type IV*—Accessory Tile, shall include those tile such as ridge, rake, hip, and valley tile used in conjunction with those tile listed in 4.1.1-4.1.3.

5. Materials and Manufacture

5.1 Cementitious materials shall conform to the following applicable ASTM specifications.

5.1.1 *Portland Cement*—Specification C 150.

5.1.2 *Modified Portland Cement*—Specification C 90.

5.1.3 *Blended Cement*—Specification C 595.

5.1.4 *Pozzolans*—Specification C 618.

5.1.5 *Ground Granulated Blast Furnace Slag*—Specification C 989.

5.1.6 Performance Specification C 1157.

5.2 Aggregates such as normal weight and lightweight shall conform to the following ASTM specifications, except that grading requirements do not apply.

5.2.1 *Normal Weight Aggregates*—Specification C 33.

5.2.2 *Lightweight Aggregates*—Specification C 331.

5.3 *Admixtures*—shall conform to the following applicable specifications.

5.3.1 *Air-Entrained Admixtures*—Specification C 260.

5.3.2 *Pigments*—Specification C 979.

5.3.3 *Other Admixtures*—Specification C 494/C 494M.

6. Standard Methods of Sampling Concrete Tile

6.1 Tile sampling shall be appropriate for one of the following three purposes:

6.1.1 Resolution of quality disputes.

6.1.2 Third party certification.

6.1.3 Production or job shipment verification.

6.2 Tile sampling for the purpose listed in 6.1 shall be taken according to Table 1. To be rated as in compliance with this standard, the indicated number of tile sampled in accordance

TABLE 1 Physical Testing Criteria

NOTE—Number of tile to be sampled and tested for determining compliance with this specification (see 6.2).

Test	Quality Dispute Resolution	Third Party Certification	Job – Production Verification	
			Up to 250 000 Tile	Over 250 000 Tile
Dimensional	5	5	5	5
Transverse	3	5	3	5
Permeability	3	3	3	5
Water Absorption	3	3	3	5
Freeze Thaw	5	5	Annual Test	Annual Test

with Table 1 must pass the specified test.

6.2.1 In the event of a failure in any of the specified tests indicated in Table 1, a second set of specimens shall be taken and tested in accordance with the criteria listed in Table 2.

6.2.2 Provided that the number of failures in the re-test sample are less than the maximum allowed in Table 2, the lot shall be rated as being in compliance with this specification.

6.3 *Sampling Procedure*—Buyer and seller shall agree on the method of sampling prior to shipment. The random sampling method shall be used.

7. Standard Methods of Testing Concrete Roof Tiles

7.1 The following tests are required on concrete roof tiles:

7.1.1 Dimensional Tolerances.

7.1.2 Freeze Thaw (see 7.3.1).

7.1.3 Transverse Strength.

7.1.4 Permeability.

7.1.5 Water Absorption.

7.2 *Testing for Dimensional Tolerances and Weight:*

7.2.1 *Dimensions*—The total variation in dimensions of tiles (length, width, and height), when measured in accordance with Test Methods C 140, shall not be more than $\pm 5\%$ from the manufacturer's designated dimensions.

7.2.2 *Weight*—The total variation in weight of tiles, when measured in accordance with Test Methods C 140 and Table 1 of this specification, shall not be more than $\pm 5\%$ from the nominal weight specified by the supplier.

7.3 *Freezing and Thawing*—Tiles shall be subjected to 50 cycles of freezing and thawing of Test Methods C 67 as modified in 7.3.4.

7.3.1 A lot shall be rated as passing without repeating a freezing and thawing test provided that a previous lot made by

TABLE 2 Retest Criteria

NOTE 1—Retest criteria of the specific test that failed (see 6.2.1).

NOTE 2—If 250 000 tiles were in the lot, then 32 specimens would be taken for the retest of the specific test that failed. If 3 or less of the 32 specimens failed, the lot would be rated as passing; however, if 4 or more of the 32 specimens failed, the lot would have failed the specific test.

Number of Tile in the Lot	Number of Specimens	Maximum Number of Failures Allowed for Acceptance
Less than 151	3	0
151–3200	13	1
3200–35 000	20	2
35 001–500 000	32	3
Over 500 000	50	5

the supplier from similar materials, by the same production plant, and within the previous 12 months, passed the test, and provided also that a sample of five tiles selected from the lot has an average and individual minimum transverse strength not less than the previously tested sample and has average and individual maximum water absorption not greater than those of the previously tested sample.

7.3.2 Only tile passing freeze-thaw testing shall be installed in areas subjected to weathering indices of 50 or greater and lot tags or certification that the lot of tile has passed the freeze-thaw testing accompanies the lot. See Fig. 1 for weathering indices map.

7.3.3 Tile not tested for freeze-thaw shall state clearly that the lot has not been tested for freeze-thaw acceptance on all lot tags or certification.

7.3.4 Modify Test Methods C 67 procedure for freezing and thawing as follows:

7.3.4.1 The test specimens shall consist of five whole tile.

7.3.4.2 The freezing trays and containers shall be of sufficient size and depth to allow the tiles to be completely submerged in water when placed horizontally.

7.3.4.3 The tile shall be completely submerged in water when the trays are placed in the freezing chamber.

7.3.4.4 Tile shall be tested individually or shall be stacked on top of each other in the tray, provided that spacers of at least ¼ in. (6 mm) thick are used between adjacent tile and that the total stack is completely submerged.

NOTE 3—A large capacity freezer is generally necessary to accomplish freezing in the manner specified in Test Methods C 67 for trays containing more than one tile. It is permitted to use custom trays to enclose the tile(s) and minimize the volume of water required to completely submerge the tile(s).

7.3.5 Tile is considered to have passed the freezing and thawing test if, at the completion of 50 cycles, all specimens

remain unbroken and no individual specimen loses more than 1 % of original dry weight.

7.4 *Transverse Strength:*

7.4.1 *Apparatus*—The transverse breaking strength of tiles shall be determined as described in the Modulus of Rupture (Flexural Test) in Test Methods C 67 except as modified in 7.4.2-7.4.9.

7.4.2 Five tiles shall be tested wet after a 24-h submersion in water at a temperature of 75 ± 10°F (24 ± 6°C) or five tiles shall be tested dry after heating in a ventilated oven for 24 h at a temperature of 230 to 239°F (100 to 115°C).

7.4.3 Tiles shall be considered to comply with this specification if they comply with either the wet or dry transverse strength required. The choice of method, wet or dry, shall be mutually agreed upon between specifier and supplier.

7.4.4 The span for the test shall be 12 in. (30.5 cm) ± 5 % or ⅔ the length of the tile, whichever is greater. The span is measured between the centers of the lower support members (see Fig. 2).

7.4.4.1 It is permitted to use a shorter span than required by 7.4.4 when the length of the tile to be tested, or the installed unsupported span of the tile, is not sufficient to allow a 12 in. (30.5 cm) span to be used. In that case a shorter span, not less than ⅓ of the length of the tile, or the total length of the longest unsupported span as installed, whichever is less, shall be used.

7.4.5 The tile shall be tested in a three-point bending mode in a horizontal plane with the bottom surface of the tile resting on two lower support members and with the load being applied to the upper (exposed) surface of the tile by a third member moving in a direction perpendicular to the plane of the tile and at mid-span (that is, equidistant from each of the lower support members). A schematic of the assembly for testing a typical "S" tile is shown in Fig. 2.

7.4.5.1 The two support members and the loading member

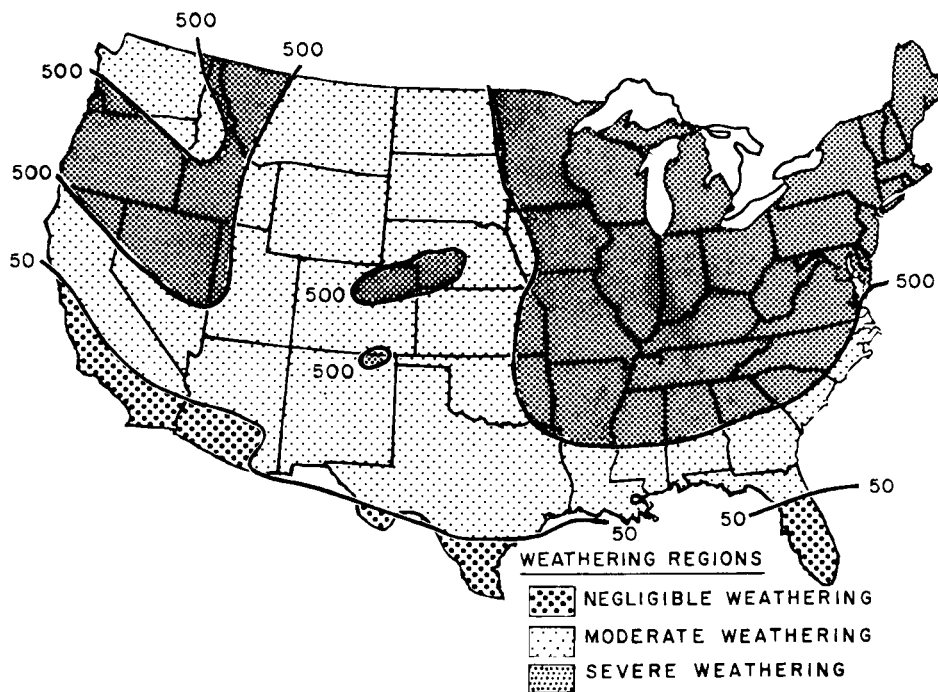
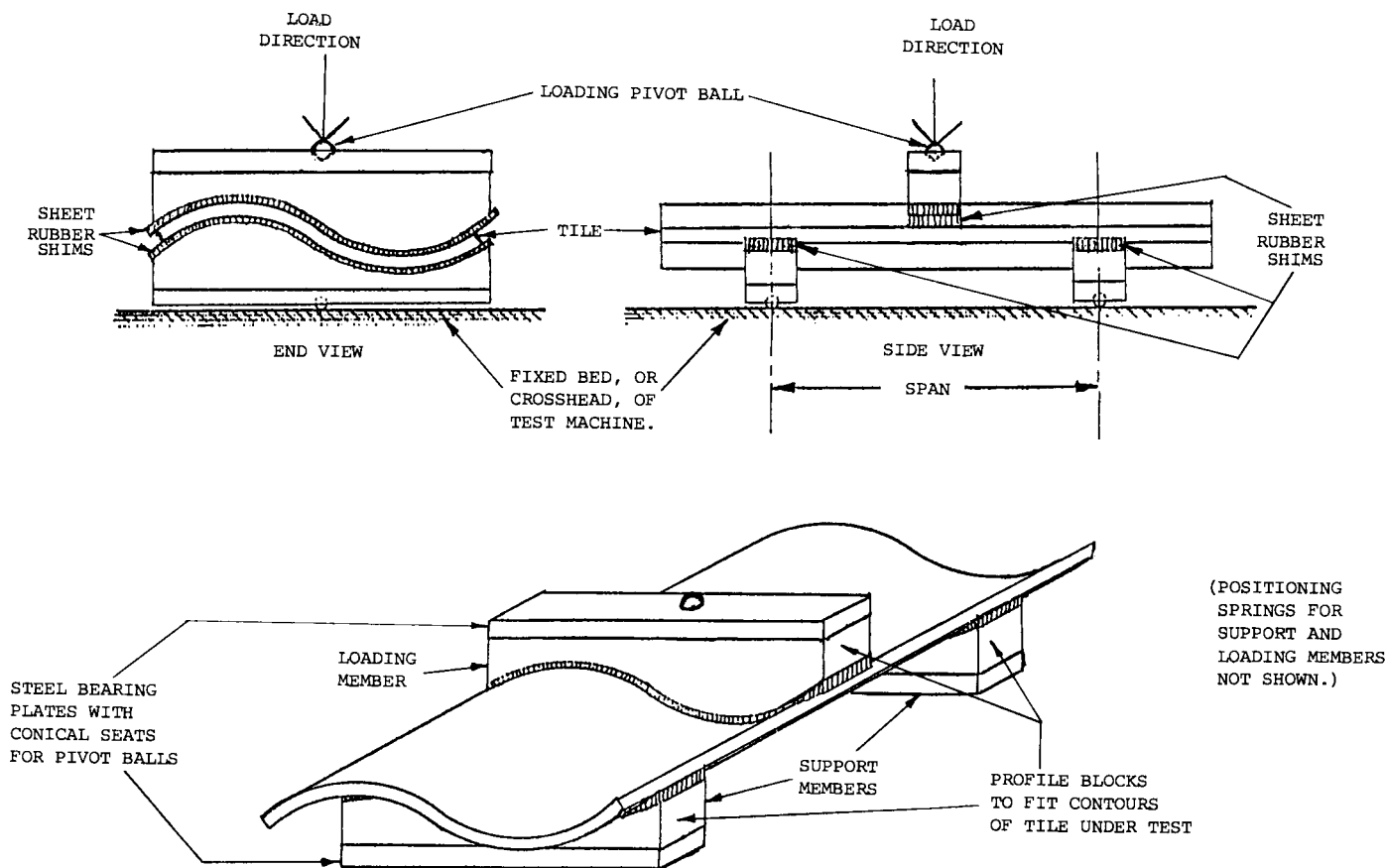

FIG. 1 Weathering Indices in the United States

ASTM C 1492



NOTE—See text for dimensions.

FIG. 2 Schematic of Assembly for Flexure Strength Testing

shall each be of metal or hardwood with 1 in. (25 mm) \pm 5 % wide faces. The faces shall be shaped (see Note 4) to closely conform to the profile of the surface of the tile upon which they bear during the test (the profile can, therefore, be different for each member depending on the profile and cross-sectional shape of the tile). The total height of the support members shall not be more than 1 in. (25 mm) greater than the rise of the profile. If hardwood, they should be backed up with steel bearing plates at least 1/2 in. (13 mm) thick. A rubber shim strip 3/16 in. (4.8 mm) \pm 10 % thick of hardness no greater than shore durometer 30 (A scale), and 1 in. (25 mm) \pm 5 % wide, shall be placed between the faces of the support and loading members and the surface of the tile.

NOTE 4—The intent of the defined loading system is (1) to apply the bending force with a loading member that pushes against as much of the profiled surface of the tile as practical, (2) to support the tile on members that support as much of the profiled surface of the tile as is practical, and (3) to ensure that the contact area of both the loading and support members is equally distributed on either side of the tile's centerline in the long direction to avoid nonsymmetrical loading.

For tile with complex profiles and cross sections but with flat bearing surfaces that are at least 50 % of the width of the tile and that are also equally distributed on either side of the length centerline, use flat support and loading members to perform this test, provided that they otherwise comply with the requirements of 7.4.4.1-7.4.5.1. When sufficient flat bearing surfaces do not exist, use wood blocks of appropriate thickness and profile and 1 in. (25 mm) wide to provide a surface that will permit load application using a flat loading member that otherwise meets the

requirements of 7.4.4.1-7.4.5.1, and causes the load to be applied to at least 50 % of the width of the tile and equally distributed on either side of the length centerline of the tile.

Each wood block used that is to provide sufficient flat surface to allow loading and supporting with the flat bearing members shall have a length of at least 25 % of the width of the tile. Such blocks shall be spaced no farther apart than 25 % of the width of the tile to avoid concentrated loading. Loading support members shall be parallel to each other and be placed in the same alignment across the width of the tile, when viewed from the end of the tile, to avoid torsional loading.

7.4.5.2 The length of the support and loading members shall not be less than the width of the tile.

7.4.5.3 Both of the support members and the loading member shall be free to rotate in the longitudinal and transverse directions of the test specimen and be adjusted so that they will exert no negligible force in these directions. It is permitted to accomplish this by spherically seated steel balls with appropriate supporting springs.

7.4.6 The tile shall be loaded uniformly and continuously, without shock, at the rate not to exceed 1000 lbf (4448 N/min) until fracture.

7.4.7 Record the load in pounds (kilograms) at the fracture of the five tiles and report the average of the five tests and the minimum individual result.

7.4.8 For a tile with a width greater than 14 in. (35.6 cm), the minimum values in Table 3 are to be adjusted proportionally to the change in width according to Eq 1.

TABLE 3 Transverse Breaking Strength, min, Lbf (N)

	Dry		Wet	
	Average of 5 Tile	Individual Tile	Average of 5 Tile	Individual Tile
High Profile	400 (1779)	350 (1556)	300 (1334)	260 (1157)
Medium Profile	300 (1334)	250 (1112)	225 (1001)	200 (890)
Low Profile	300 (1334)	250 (1112)	225 (1001)	200 (890)

$$\text{Transverse Break strength} = \frac{\text{Width (in.)}}{14} \times (\text{Value in Table 3}) \quad (1)$$

7.4.9 The minimum values required shall be those listed in Table 3.

7.5 Permeability:

7.5.1 *Apparatus*—Construct a 3 ft (1 m) by 3 ft (1 m) frame, as shown in Fig. 3, at a pitch not to exceed $30^\circ \pm 1^\circ$ without nails or roofing felt. Provide access to the underside of the roof for observation. Provide illumination to the underside of the tile, if required, to identify the presence of free water on the underside of the tile.

7.5.1.1 Install the tiles as would be installed during field application for tile headlap without the use of nails.

7.5.1.2 Place a 1/2 in. diluge pipe (12 mm) inside diameter with 1/16 in. (2 mm) holes on 1 1/2 in. (38 mm) over the top course of the roof to simulate run down from the higher course (see Fig. 3). Place a spray nozzle over the center of the tile to simulate direct rainfall and such that every tile on the roof will receive an equal volume of water. The application of water shall be such that a minimum volume is lost from overspray. Water shall be maintained at $75 \pm 5^\circ\text{F}$ ($24 \pm 3^\circ\text{C}$).

7.5.2 *Test Procedure*—The simulated rainfall shall be applied to the roof deck at the following combined rates:

7.5.2.1 *Via Diluge Pipe*—6 in. (150 mm)/h.

7.5.2.2 *Via Spray Nozzle*—3 in. (75 mm)/h.

7.5.2.3 Total simulated rainfall shall be 9 in. (225 mm)/h.

7.5.2.4 Calculate the flow rates required for the spray unit to achieve the simulated rainfall for a given roof area by Eq 2.

$$Q \text{ (gal/min)} = 0.031 \times A \quad (2)$$

where:

A = actual roof test area in square feet.

Metric Equivalent:

$$Q \text{ (L/min)} = 1.25 \times A$$

where:

A = actual roof test area in square metres.

7.5.2.5 The flow rate for the diluge pipe shall be twice that calculated for the spray unit above.

7.5.2.6 The flow rate shall be monitored by means of a flowmeter.

7.5.2.7 The flow of water shall be maintained for a time period of 2 h.

7.5.3 *Acceptance Criteria*—The tile shall be considered to have passed the test if after 2 h:

7.5.3.1 Free water has not formed on the underside of the tile, and

7.5.3.2 Not more than 25 % of the visible underside of any one tile shall show dampness.

7.5.3.3 *Example Calculation*—If a test apparatus provides a tile roof area of 4 by 4 ft, then you will have 16 ft² of roof deck. Flow $Q = 0.031 \times 16 \text{ ft}^2 = 0.50 \text{ gal/min}$ for the spray unit. The diluge unit is twice the spray unit and would therefore have a flow of 1.0 gal/min. The combined flow would be a total of 1.5 gal/min on the tile roof.

7.6 Water Absorption:

7.6.1 *Apparatus and Procedure*—The procedures and apparatus should be in accordance with the section on absorption in Test Methods C 140.

7.6.2 The tile shall then be classified according to Table 4.

7.6.3 The maximum percent water absorption (average of 5 units) and individual specimen maximum, shall be as listed in Table 5.

ASTM C 1492

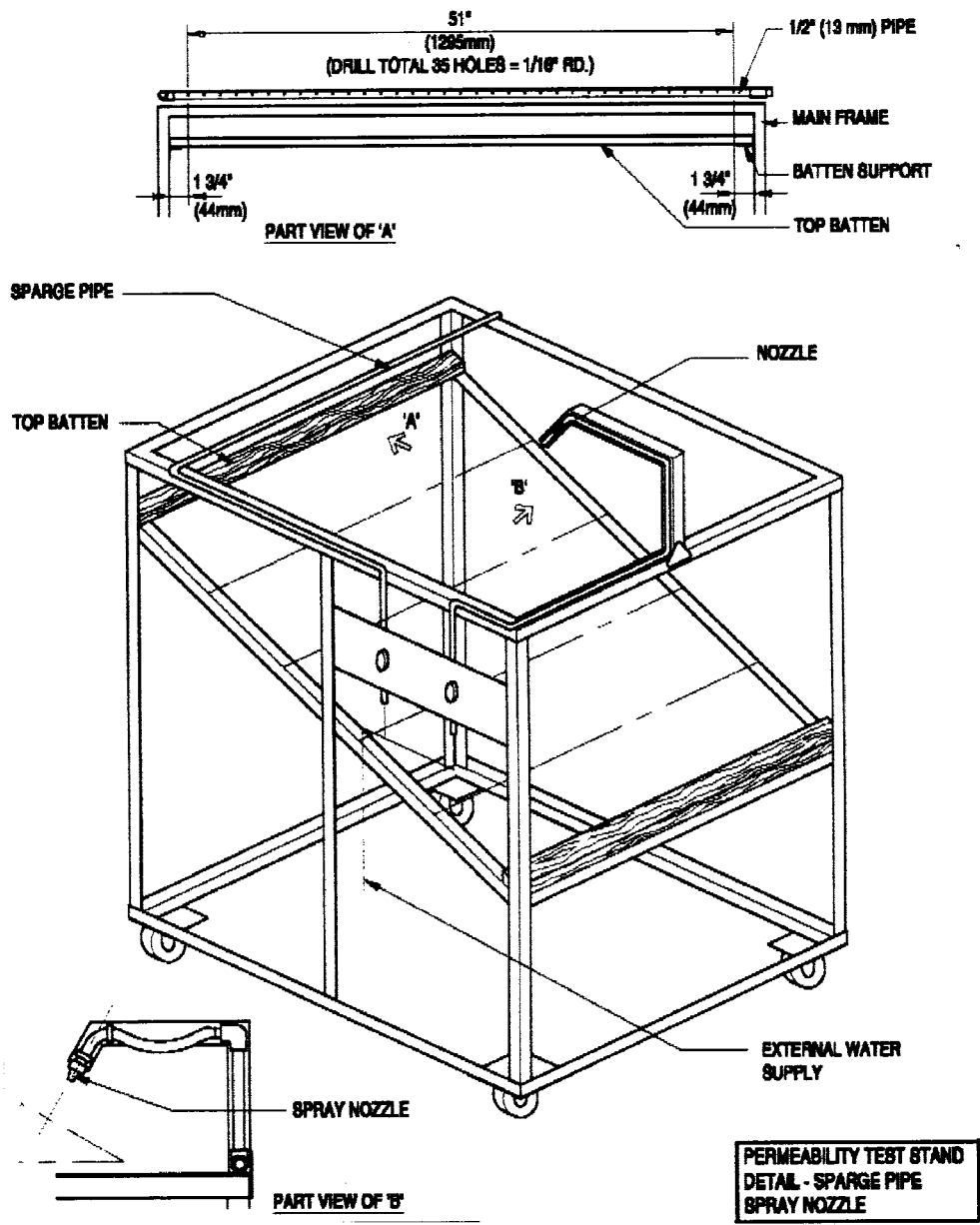

FIG. 3 Diluge Pipe

TABLE 4 Weight Classification

Weight Classification	Oven Dry Weight of Tile (lb/ft ³)
Normal	Greater than 125
Medium	105 to 125
Lightweight	Less than 105

TABLE 5 Water Absorption

Weight Classification	Max % Absorption, Average of Five Tiles	Max % Absorption, Individual Tile
Normal	10.5 %	12.5 %
Medium	14.5 %	16.5 %
Lightweight	18.0 %	20.0 %

8. Texture and Color

8.1 The texture and color of tiles should be specified by the purchaser and mutually agreed upon between purchaser and supplier with reference to a sample of the type specified representing the possible range of textures and shades of color.

9. Inspection

9.1 Inspection of the material covered by this specification shall be agreed upon between the purchaser and the supplier as

part of the purchase contract.

9.2 The tile, as delivered to the site, shall by visual inspection conform to the requirements specified by the purchaser or to the sample or samples approved as the standard of comparison and to the samples passing the tests for physical requirements. Minor indentations, chips, or surface crazing incidental to the usual method of manufacture, shall not be deemed grounds for rejection.

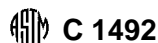

9.3 After tile are placed in use, the manufacturer or manufacturer's shall not be held responsible for compliance of the tile with the requirements of this specification for color or damage caused during installation.

10. Rejection and Rehearing

10.1 Material that fails to conform to the requirements of this specification can be rejected. Rejection should be promptly reported in writing to the supplier. In case of rejection, and if not specifically excluded in the purchase order or contract, the supplier shall have the right to inspect the rejected lot and resubmit the lot after removal of the material not conforming to the specified requirements, provided this is done within 20 days after receipt of notice of the specific cause for rejection.

10.2 If the shipment fails to conform to the requirements for the type of tile specified, the manufacturer is permitted to sort it, and new specimens shall be selected by the purchaser from the retained lot and tested at the expense of the supplier. In the case the second set of specimens fails to meet the requirements, the entire shipment shall be rejected.

11. Certification

11.1 When specified in the purchase order or contract, the purchaser shall be furnished certification that a representative sample of each lot has been either tested or inspected as required by this specification and the requirements have been met. When specified in the purchase order or contract, a report of the test results shall be furnished.

NOTE 5—Unless otherwise specified in the purchase contract, the cost of the tests is typically borne as follows: If the results of the test show that the tile do not conform to the requirements of this specifications, the cost is typically borne by the seller. If the results of the test show that the tile do conform to the requirements of this specification, the cost is typically borne by the purchaser.

12. Keywords

12.1 absorption; concrete; concrete roof tile; durability; freeze thaw durability; permeability; roof; roofing; tile; transverse breaking strength

ANNEX

(Mandatory Information)

A1. EXPLANATORY INFORMATION

A1.1 The effect of weathering on tile is related to the weathering index, which for any locality is the product of the average annual number of freezing cycle days and the average annual winter rainfall in inches (millimetres), defined as follows.⁵

A1.2 *Freezing Cycle Day*—any day during which the air temperature passes either above or below 32°F (0°C). The average number of freezing cycle days in a year may be taken to equal the difference between the mean number of days during which the minimum temperature was 32°F or below, and the mean number of days during which the maximum

temperature was 32°F or below.

A1.3 *Winter Rainfall*—the sum, in inches (millimetres), of the mean monthly corrected precipitation (rainfall) occurring during the period between and including the normal date of the first killing frost in the fall and the normal date of the last killing frost in the spring. The winter rainfall for any period is equal to the total precipitation less one tenth of the total fall of snow, sleet, and hail. Rainfall for a portion of a month is prorated.

A1.4 Fig. 1 indicates general areas of the United States which correspond to the weathering index categories. The index for geographic locations near the 50 line should be determined by analysis of weather bureau local climatological summaries, with due regard to the effect of microclimatic conditions, especially altitude.

⁵ Data needed to determine the weathering for any locality may be found or estimated from tables of Local Climatological Data – Annual Summary with Comparative Data available from the National Oceanic and Atmospheric Administration.

The American Society for Testing and Materials takes no position respecting the validity of any patent rights asserted in connection with any item mentioned in this standard. Users of this standard are expressly advised that determination of the validity of any such patent rights, and the risk of infringement of such rights, are entirely their own responsibility.

This standard is subject to revision at any time by the responsible technical committee and must be reviewed every five years and if not revised, either reapproved or withdrawn. Your comments are invited either for revision of this standard or for additional standards and should be addressed to ASTM Headquarters. Your comments will receive careful consideration at a meeting of the responsible technical committee, which you may attend. If you feel that your comments have not received a fair hearing you should make your views known to the ASTM Committee on Standards, at the address shown below.

This standard is copyrighted by ASTM, 100 Barr Harbor Drive, PO Box C700, West Conshohocken, PA 19428-2959, United States. Individual reprints (single or multiple copies) of this standard may be obtained by contacting ASTM at the above address or at 610-832-9585 (phone), 610-832-9555 (fax), or service@astm.org (e-mail); or through the ASTM website (www.astm.org).