



Standard Test Method for Wind Resistance of Concrete and Clay Roof Tiles (Mechanical Uplift Resistance Method)¹

This standard is issued under the fixed designation C 1568; the number immediately following the designation indicates the year of original adoption or, in the case of revision, the year of last revision. A number in parentheses indicates the year of last reapproval. A superscript epsilon (ϵ) indicates an editorial change since the last revision or reapproval.

1. Scope

1.1 This test method covers a procedure to determine the mechanical uplift resistance of concrete and clay roof tiles, which relates to the wind resistance of an air-permeable roof tile system as applied to a roof.

1.2 The procedure covers mechanically-fastened attachment systems, adhesive-set attachment systems, and mortar-set attachment systems, or combinations of attachment systems, that are used to apply tile to a roof.

1.3 The values stated in inch pound units are to be regarded as the standard. The values in parentheses are given for reference only.

1.4 *This standard does not purport to address all of the safety concerns, if any, associated with its use. It is the responsibility of the user of this standard to establish appropriate safety and health practices and determine the applicability of regulatory limitations prior to use.*

2. Referenced Documents

2.1 ASTM Standards:

C 43 Terminology of Structural Clay Products²

C 67 Test Methods for Sampling and Testing Brick and Structural Clay Tile²

C 140 Test Methods of Sampling and Testing Concrete Masonry Units²

C 1167 Specification for Clay Roof Tiles²

C 1492 Specification for Concrete Roof Tiles²

2.2 SBCCI Standard:

SBCCI SSTD 11 SBCCI Test Standard for Determining Wind Resistance of Concrete or Clay Roof Tiles

NOTE 1—This standard is based on the International Code Council's ICC/SBCCI SSTD 11 Test Standard for Determining Wind Resistance of Concrete or Clay Roof Tiles, and work derived from the tile industry's testing programs completed in the Redland Wind Tunnel in the UK.

2.3 ASCE Standard:

ASCE 7 Minimum Design Loads for Buildings and Other Structures

3. Terminology

3.1 *Definitions*—For definitions of terms used in this test method refer to Terminology C 43, and Specifications C 1167 and C 1492.

4. Significance and Use

4.1 The method of attachment of roof tiles to the roof deck, or support structure, is one factor in the resistance of concrete and clay roof tiles to the action of wind. Several systems of attachment, and even combinations of systems, are used in the application of tile to a roof. The mechanical uplift resistance of the tile, when applied to the roof by any attachment system approved by, and in accordance with, the manufacturer's instructions, is a primary factor in the tile's resistance to the action of wind. This test method determines the mechanical uplift resistance that is related to resistance to the uplift forces acting as a result of wind. Natural wind conditions differ with respect to intensity, duration, and turbulence; these conditions are beyond the means of this test method to simulate.

5. Apparatus

5.1 A test apparatus shown in Fig. 1 shall be used to test the mechanical uplift resistance of roof tiles. The triangulated framework and loading bar shall be constructed of tubular steel of sufficient strength to remain rigid when loads of up to 500 lbf are applied to the test tile. The frame shall be fixed to the floor to prevent movement of the frame and to provide a solid reference plane for deflection measurements. The joints of the frame shall be rigid, however, the loading bar rotates about the frame to facilitate the loading of the test tile. The other end of the loading bar is attached to a hydraulic jack, or similarly controllable mechanical device, which allows the load to be applied gradually and to be maintained at any desired load while deflections are being measured. The load is applied to the tile through a load transfer device (steel bolt with chain linkage) and is measured by a load cell capable of operating at up to 500 lbf. The roof framing used for the specimens shall be either fixed to the floor, anchored to the triangulated framework, or weighted to prevent the roof framing from being lifted

¹ This test method is under the jurisdiction of ASTM Committee C15 on Manufactured Masonry Units and is the direct responsibility of Subcommittee C15.06 on Roofing Tile.

Current edition approved June 10, 2003. Published July 2003.

² *Annual Book of ASTM Standards*, Vol 04.05.

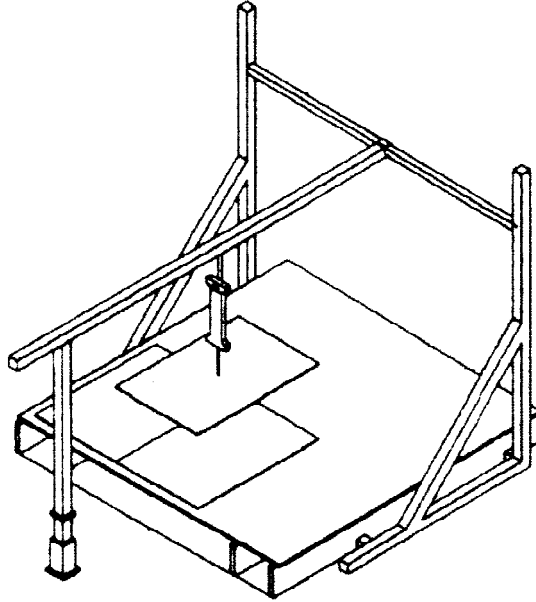

FIG. 1 Mechanical Uplift Resistance Test Apparatus

during the test. Deflections are measured by dial gages firmly fixed to a reference plane so that as the tile is loaded and the tile or test frame distorts, the reference position remains static. A dial gage plunger is placed on top of the tile nose in a central position to measure the mechanical uplift of the tile. Additional dial gages are required depending on the method of tile attachment: (a) in mechanically fastened systems, a dial gage at the fastener in the bead of the tile to measure withdrawal of the fastener; (b) when a clip is used, a dial gage at the clip to measure deflection and permanent set of the clip; and (c) when a barrel tile is used, a dial gage at the roll of the tile to measure the deflection of the roll due to the rotation of this type of tile.

6. Procedure

6.1 Drill the test tile and install the steel-bolt load-transfer device into the tile as follows:

6.1.1 Drill a hole along the centerline of the exposed width of the tile at 0.76 times the tile length from the head of the tile using a 1/4 in. (6 mm) non-percussion, cutting carbide bit. Discard any tile that, after drilling, exhibits spalling or chipping around the hole in excess of 1/4 in. (6 mm). Install a 4 in. (100 mm) long, 1/4 in. (6 mm) diameter steel bolt with a 1 in. (25 mm) diameter steel washer under the tile through the hole. It is not prohibited to shape the washer to match the contour of the underside of the tile. It is also not prohibited to omit the washer.

6.2 Install the tile in the same manner as on a roof, in accordance with the manufacturer's instructions, on a small section of roof deck constructed to fit within the frame of the test apparatus as shown in Fig. 1. The rafters shall be securely anchored to the frame or the floor and the sheathing firmly nailed to the rafters. If the roofing underlayment transfers loads, the underlayment shall be installed and, if required, battens shall be nailed to the sheathing. The tile to be tested shall then be installed onto the roof deck section. Tiles in the course below the test tile shall be installed to ensure that the tile

being tested is at the correct angle to the sheathing with the nose of the test tile at the correct angle to the tile course below.

6.3 The loading shall be applied through a chain linkage attached to the load transfer bolt at a rate that will cause deflection of the tile nose of approximately 1 in. (25 mm) per minute.

6.3.1 The load cell shall be zeroed to take out the weight of the load transfer bolt and chain linkage.

6.4 Each type of tile installation shall be tested three (3) times with a new tile and fixing. The position of the tile shall be moved each time so that new fixings will not be affected by any damage caused by previous tests. The sheathing, underlayment, and battens shall be replaced when damage is such that the test result is compromised. If the failure of any of the three (3) tests varies from the average failure by more than twenty percent (20 %), then three (3) additional tests shall be performed to provide a total of six (6) tests.

7. Conditioning

7.1 See the conditioning specified for each specific installation system.

8. Failure

8.1 The failure criteria are described for each specific installation system and tile.

9. Calculation of Mechanical Uplift Resistance

9.1 The reported mechanical uplift resistance shall be the failure load corresponding to the failure criteria described for each specific attachment system, and adjusted as in 9.2.

9.2 The failure load shall be adjusted when the attachment system is used to provide resistance to more than one (1) tile by dividing the failure load by a load factor of two (2). If the attachment system provides resistance for only one (1) roof tile, the load factor is one (1).

9.3 The mechanical uplift resistance is the net result of the Attachment resistance minus the tile's gravity moment.

- W = average weight of tile (lbf).
 θ = test roof deck slope (degrees).
 α = installed tile angle with respect to the test roof deck (degrees).
 L_g = tile gravitational moment arm (ft). The tile gravitational moment arm, L_g , is the orthogonal distance from the tile's center of gravity to the tile's axis of rotation.
 L_f = tile attachment moment arm (ft). The tile attachment moment arm, L_f , is the orthogonal distance from the point of load application to the tile's axis of rotation.
 F = failure load as determined under 9.2 (lbf).
 $S.F.$ = safety factor.
 M_g = tile gravitational moment (ft-lbf). The gravitational moment, M_g , is the moment created by the dead weight of the tile for the roof deck slope.
 M_f = fastening system attachment moment (ft-lbf). The attachment moment, M_f , is the allowable uplift resistance for the attachment resistance for the roof deck slope.
 $M_g = W [\cos (\theta - \alpha) (L_g)]$
 $M_f = F [\cos (\theta - \alpha) (L_f - M_f, S.F.)]$

10. Tile Installation Using Mechanically-Fastened Systems

10.1 Tile shall be installed in accordance with the manufacturer's instructions, using supplementary clips if so specified.

10.2 It is not prohibited to omit the tile underlayment system.

10.3 When a hot-mopped underlayment system is used, the underlayment shall be left to reach ambient temperature before tile installation.

10.4 For a tile fixed without a clip, one dial gage shall be mounted to measure the upward deflection of the tile $\frac{3}{4}$ in. (19 mm) from the nose of the tile and in line with the point of application of the load.

10.5 For a tile fixed with a clip, load the tile in such a manner that the load and deflection can be measured at several levels of deflection up to a maximum of $\frac{1}{4}$ in. (6 mm). At a deflection of $\frac{1}{4}$ in. (6 mm), the load shall be removed and the permanent set of the clip measured, then the loading shall be taken to ultimate failure of either the fixing or the tile. For a tile fixed with a clip, one dial gage shall be mounted to measure the deflection at the clip position.

10.6 Failure Criteria:

10.6.1 For a tile without clips, failure of the tile's mechanically-fastened attachment system shall be considered as the load required to deflect the nose of the tile by two (2) in. (51 mm), or to break the tile, or to cause $\frac{1}{4}$ in. (6 mm) withdrawal of the fastener (nail, screw, etc.) at the tile head. For a tile with clips, failure of the tile's mechanically-fastened attachment system shall be considered as the lower of the loads required to develop a permanent set at the clip of $\frac{1}{8}$ in. (3 mm), or a $\frac{1}{4}$ in. (6 mm) withdrawal of the fastener (nail, screw, etc.) at the tile head. For a barrel tile with clips, failure of the tile's

mechanically-fastened attachment system shall be considered as the lower of the loads required to develop a permanent set at the clip of $\frac{1}{8}$ in. (3 mm), or a $\frac{1}{4}$ in. (6 mm) withdrawal of the fastener (nail, screw, etc.) at the tile head, or a deflection of two (2) in. (51 mm) at the roll of the tile. In all cases, if the ultimate failure of the mechanically-fastened attachment system or the tile occurs before any one of the above criteria are met, then the load at ultimate failure shall be considered as failure of the tile's mechanically-fastened attachment system.

10.6.2 The mechanical uplift resistance of the mechanically-fastened tile is the lowest load corresponding to any of the failure criteria described in 10.6.1, adjusted in accordance with Section 9.

11. Tile Attachment Using Adhesive-Set Systems

11.1 The adhesive system shall be installed in accordance with the manufacturer's instructions using supplementary clips if so specified.

11.2 When a hot-mopped underlayment system is used, the underlayment shall be left to reach ambient temperature before tile installation.

11.3 Tiles shall be at a temperature of 1000°F (380°C) plus or minus 50°F ($\pm 30^\circ\text{C}$) when installed. The adhesive system shall be cured in accordance with the manufacturer's instructions. Testing must be completed within 28-days of installation.

11.4 Specimens shall be tested at a surface temperature of 750°F (210°C) plus or minus 50°F ($\pm 30^\circ\text{C}$) measured with a surface-mounted thermocouple and recorded on a chart to confirm that the surface temperature meets the required test temperature.

11.5 One dial gage shall be mounted to measure the upward deflection of the tile $\frac{3}{4}$ in. (19 mm) from the nose of the tile and in line with the point of application of the load.

11.6 For a tile fixed with a clip, load the tile in such a manner that the load and deflection can be measured at several levels of deflection up to a maximum of $\frac{1}{4}$ in. (6 mm). At a deflection of $\frac{1}{4}$ in. (6 mm), the load shall be removed and the permanent set of the clip measured, then the loading shall be re-applied and increased until ultimate failure of either the attachment system or the tile. For a tile fixed with a clip, one dial gage shall be mounted to measure the deflection at the clip position.

11.7 Failure Criteria:

11.7.1 Failure of the tile's adhesive-set attachment system shall be considered as the load required to cause deflection without any further increase in the load, or to cause a separation of the system, or to cause the tile to break. An adhesive-set attachment system that includes mechanical fasteners and/or clips shall use the failure criteria of this section and 10.6 for the fasteners and/or clips.

11.7.2 The mechanical uplift resistance of the adhesive-set tile is the lowest load corresponding to any of the failure criteria in 11.7.1, adjusted in accordance with Section 9.

12. Tile Installation Using Mortar-Set Systems

12.1 The mortar-set system shall be mixed and installed in accordance with the manufacturer's instructions.

12.2 When a hot-mopped underlayment system is used, the underlayment shall be left to reach ambient temperature before tile installation.

12.3 Tiles shall be at a temperature of 1000°F (380°C) plus or minus 50°F (30°C) when installed. It is not prohibited to begin testing 1-day (24-h) after installation. Testing must be completed within 28-days of installation.

12.4 Tile shall be tested at a surface temperature of 75°F (240°C) plus or minus 50°F ($\pm 30^\circ\text{C}$) measured with a surface-mounted thermocouple and recorded on a chart to confirm that the surface temperature meets the required test temperature.

12.5 One dial gage shall be mounted to measure the upward deflection of the tile $\frac{3}{4}$ in. (19 mm) from the nose of the tile and in line with the point of application of the load.

12.6 For a tile fixed with a clip, load the tile in such a manner that the load and deflection can be measured at several levels of deflection up to a maximum of $\frac{1}{4}$ in. (6 mm). At a deflection of $\frac{1}{4}$ in. (6 mm), the load shall be removed and the permanent set of the clip measured, then the loading shall be re-applied and increased until ultimate failure of either the attachment system or the tile. See Section 10.6 for the failure criteria for clips. For a tile fixed with a clip, one dial gauge shall be mounted to measure the deflection at the clip position.

12.7 *Failure Criteria:*

12.7.1 Failure of the tile's mortar-set attachment system shall be considered as the load required to cause deflection without any further increase in the load, or to cause a separation of the system, or to cause the tile to break. A mortar-set attachment system that includes mechanical fasteners and/or clips shall use the failure criteria of this Section and Section 10.6 for the fasteners and/or clips.

12.8 The mechanical uplift resistance of the mortar-set tile is the lowest load corresponding to any of the failure criteria in 12.7.1, adjusted in accordance with Section 9.

13. Testing of Hip/Ridge Roof Tile

13.1 Install one of the two load transfer devices to the test hip/ridge tiles as follows.

13.1.1 Drill a hole along the centerline of the exposed width of the tile at 0.50 times the tile length from the head of the tile using a $\frac{1}{4}$ in. (6 mm) non-percussion, cutting carbide bit. Discard any tile that, after drilling, exhibits spalling or chipping around the hole in excess of $\frac{1}{4}$ in. (6 mm). Install a $\frac{1}{4}$ in. (6 mm) diameter with or without a 1 in. (25 mm) diameter steel

washer under the tile through the hole. It is not prohibited to shape the washer to match the contour of the underside of the tile. It is also not prohibited to omit the washer.

13.1.2 Use a 24 in. (610 mm) long by $1 \frac{5}{8}$ in. (41 mm) wide steel bar suspended underneath the center of the tile. Attach an eyebolt to the bar 1 in. (25 mm) from each end of the bar. Connect the load cell by a chain sling to the eyebolts.

13.2 The tile attachment system shall be installed in accordance with the manufacturer's instructions.

13.3 When using an adhesive-set attachment system, the adhesive shall be cured in accordance with the manufacturer's instructions, and testing shall be completed within 28 days of application.

13.4 When using a mortar-set attachment system, the mortar shall be cured in accordance with the manufacturer's instructions, and testing shall be completed within 28 days of application.

13.5 The hip/ridge tile shall be installed on a roof assembly in the same manner as on a roof. The test roof deck section and test assembly shall fit within the frame as shown in Fig. 2. The rafters shall be securely anchored to the floor or to the frame, and the sheathing shall be firmly nailed to the rafters. If the roofing underlayment transfers loads, the underlayment shall be installed and, if required, battens shall be nailed to the sheathing. The tile installation to be tested is then installed onto the roof deck section in the test frame.

13.6 When a hot-mopped underlayment system is used, the underlayment shall be left to reach ambient temperature before tile installation.

13.7 Tiles shall be at a temperature of 1000°F (380°C) plus or minus 50°F ($\pm 30^\circ\text{C}$) when installed. It is not prohibited to begin testing 1 day (24 hours) after installation. Testing must be completed within 28-days of installation.

13.8 Tile shall be tested at a surface temperature of 750°F (240°C) plus or minus 50°F ($\pm 30^\circ\text{C}$) measured with a surface-mounted thermocouple and recorded on a chart to confirm that the surface temperature meets the required test temperature.

13.9 The load cell shall be attached to the tile using one of the load transfer devices in 13.1. The load cell shall be zeroed to take out the weight of the steel bolt load transfer device, the steel bar, and the chain linkage.

13.10 *Failure Criteria:*

13.10.1 Failure of the hip/ridge tile's attachment system shall be considered as the load required to cause deflection

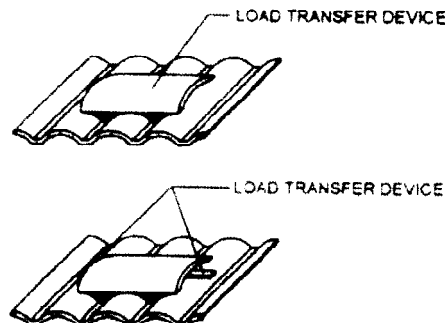

FIG. 2 Test Arrangement for Hip/Ridge Roof Tiles

without any further increase in the load, or to cause a separation of the system, or to cause the tile to break. An adhesive-set system or mortar-set system that includes mechanical fasteners in the system shall use the failure criteria of this Section and Section 10.6 for the fasteners and/or clips.

13.11 The hip/ridge tile's mechanical uplift resistance is the lower of the loads in 13.10.1.

14. Report

14.1 The report shall include the following:

14.1.1 A statement that the test or tests were conducted in accordance with these test procedures.

14.1.2 In the event that any deviations from these test procedures are used, the report shall explain the reasons for, and effect of, any deviations on the test results.

14.1.3 Descriptions of the framing system, and the concrete or clay roof tiles, with sketches. The description of the concrete or clay roof tiles shall include as a minimum the following: tile profile, location of nail holes, location of clips (if any), headlap, side laps and exposed width, thickness, weight, and the uplift resistance moment arm.

14.1.4 A detailed description, with sketches, of the test setup, and details of any auxiliary apparatus, and equipment.

14.1.5 A detailed description of the method of loading, and method of making measurements.

14.1.6 All data obtained during the test:

14.1.6.1 Test deck slope,

14.1.6.2 Test tile slope,

14.1.6.3 Average tile weight,

14.1.6.4 Temperatures,

14.1.6.5 Moment arms,

14.1.6.6 Tile gravitational moment,

14.1.6.7 Safety factor, and

14.1.6.8 Other data required for analysis.

14.1.7 All pertinent observations on the behavior of the concrete or clay roof tiles during the test including, as a minimum, the following:

14.1.7.1 Failure mode: Specify the failure criteria that determined the failure load. When a mechanically-fastened attachment system is tested, specify the type of failure as either

(a) deflection of the nose of the tile by 2 in. (51 mm), (b) ¼ in. (6 mm) withdrawal of the fastener (nail, screw, etc.) at the tile head, or, (c) that the tile broke. When adhesive-set or mortar-set systems are tested, specify the type of separation that occurred at failure. The separation of the system is to be recorded as either (a) between the adhesive or mortar and the tile, (b) within the adhesive or mortar, (c) between the adhesive or mortar and the underlayment, (d) separation of the underlayment, or (e) that the tile broke.

14.1.7.2 Deflections recorded.

14.1.7.3 Any tile rotation observed.

14.2 Details of the adhesive and mortar system mixing, installation and curing.

14.3 Conditioning details.

14.4 Quantity of adhesive or mortar used to attach the test tile.

14.5 The contact area between the test tile and the adhesive or mortar system.

14.6 Calculated mechanical uplift resistance for the specific attachment system used.

14.7 Fastening system attachment moment.

15. Precision and Bias

15.1 The precision of method CXXXX for measuring the Mechanical Uplift Resistance of Concrete and Clay Roof Tile is being determined and will be available on or before December 2003. It is not feasible to specify the precision at this time because there has not been sufficient experience with the method in a sufficient number of different test facilities.

15.2 It is not possible to specify the bias in method CXXXX for measuring the Mechanical Uplift Resistance of Concrete and Clay Roof Tiles because no material having an accepted reference value is available.

16. Keywords

16.1 adhesive-set attachment systems; air-permeable roof system; clay roof tile; concrete roof tile; mechanically-fastened attachment systems; mechanical uplift resistance; mortar-set attachment systems; wind resistance

ASTM International takes no position respecting the validity of any patent rights asserted in connection with any item mentioned in this standard. Users of this standard are expressly advised that determination of the validity of any such patent rights, and the risk of infringement of such rights, are entirely their own responsibility.

This standard is subject to revision at any time by the responsible technical committee and must be reviewed every five years and if not revised, either reapproved or withdrawn. Your comments are invited either for revision of this standard or for additional standards and should be addressed to ASTM International Headquarters. Your comments will receive careful consideration at a meeting of the responsible technical committee, which you may attend. If you feel that your comments have not received a fair hearing you should make your views known to the ASTM Committee on Standards, at the address shown below.

This standard is copyrighted by ASTM International, 100 Barr Harbor Drive, PO Box C700, West Conshohocken, PA 19428-2959, United States. Individual reprints (single or multiple copies) of this standard may be obtained by contacting ASTM at the above address or at 610-832-9585 (phone), 610-832-9555 (fax), or service@astm.org (e-mail); or through the ASTM website (www.astm.org).