



Designation: C 361 – 99

Standard Specification for Reinforced Concrete Low-Head Pressure Pipe¹

This standard is issued under the fixed designation C 361; the number immediately following the designation indicates the year of original adoption or, in the case of revision, the year of last revision. A number in parentheses indicates the year of last reapproval. A superscript epsilon (ϵ) indicates an editorial change since the last revision or reapproval.

This standard has been approved for use by agencies of the Department of Defense.

1. Scope

1.1 This specification covers reinforced concrete pipe intended to be used for the construction of pressure pipelines with low internal hydrostatic heads generally not exceeding 125 ft.

1.2 A complete metric companion to Specification C 361 has been developed—C 361M; therefore, no metric equivalents are presented in this specification.

NOTE 1—Field tests on completed portions of the pipeline are not covered by this specification for the manufacture of the pipe but should be included in specifications for pipe laying.

2. Referenced Documents

2.1 ASTM Standards:

- A 27/A 27M Specification for Steel Castings, Carbon, for General Application²
- A 36/A 36M Specification for Carbon Structural Steel³
- A 82 Specification for Steel Wire, Plain, for Concrete Reinforcement³
- A 185 Specification for Steel Welded Wire, Fabric, Plain, for Concrete Reinforcement³
- A 283/A 283M Specification for Low and Intermediate Tensile Strength Carbon Steel Plates³
- A 496 Specification for Steel Wire, Deformed, for Concrete Reinforcement³
- A 497 Specification for Steel Welded Wire Fabric, Deformed, for Concrete Reinforcement³
- A 570/A 570M Specification for Steel, Sheet and Strip, Carbon, Hot-Rolled, Structural Quality⁴
- A 575 Specification for Steel Bars, Carbon, Merchant Quality, M-Grades⁵
- A 576 Specification for Steel Bars, Carbon, Hot-Wrought, Special Quality⁵
- A 611 Specification for Steel, Sheet, Carbon, Cold-Rolled, Structural Quality⁴

- A 615/A 615M Specification for Deformed and Plain Billet-Steel Bars for Concrete Reinforcement³
- A 675/A 675M Specification for Steel Bars, Carbon, Hot-Wrought, Special Quality, Mechanical Properties⁵
- C 31 Practice for Making and Curing Concrete Test Specimens in the Field⁶
- C 33 Specification for Concrete Aggregates⁶
- C 39 Test Method for Compressive Strength of Cylindrical Concrete Specimens⁶
- C 150 Specification for Portland Cement⁷
- C 260 Specification for Air-Entraining Admixtures for Concrete⁶
- C 309 Specification for Liquid Membrane-Forming Compounds for Curing Concrete⁶
- C 497 Test Methods for Concrete Pipe, Manhole Sections, or Tile⁸
- C 595 Specification for Blended Hydraulic Cements⁷
- C 618 Specification for Fly Ash and Raw or Calcined Natural Pozzolan for Use as a Mineral Admixture in Portland Cement Concrete⁶
- C 822 Terminology Relating to Concrete Pipe and Related Products⁸
- D 395 Test Methods for Rubber Property—Compression Set⁹
- D 412 Test Methods for Vulcanized Rubber and Thermoplastic Rubbers and Thermoplastic Elastomers Tension⁹
- D 471 Test Method for Rubber Property—Effect of Liquids⁹
- D 573 Test Method for Rubber—Deterioration in an Air Oven⁹
- D 698 Test Method for Laboratory Compaction Characteristics of Soil Using Standard Effort (12 400 ft-lbf/ft³ (600 kN-m/m³))¹⁰
- D 1149 Test Method for Rubber Deterioration—Surface Ozone Cracking in a Chamber⁹
- D 2240 Test Method for Rubber Property—Durometer Hardness⁹
- D 4253 Test Method for Maximum Index Density and Unit

¹ This specification is under the jurisdiction of ASTM Committee C-13 on Concrete Pipe and is the direct responsibility of Subcommittee C13.04 on Low Head Pressure Pipe.

Current edition approved April 10, 1999. Published July 1999. Originally published as C 361 – 55 T. Last previous edition C 361 – 98.

² *Annual Book of ASTM Standards*, Vol 01.02.

³ *Annual Book of ASTM Standards*, Vol 01.04.

⁴ *Annual Book of ASTM Standards*, Vol 01.03.

⁵ *Annual Book of ASTM Standards*, Vol 01.05.

⁶ *Annual Book of ASTM Standards*, Vol 04.02.

⁷ *Annual Book of ASTM Standards*, Vol 04.01.

⁸ *Annual Book of ASTM Standards*, Vol 04.05.

⁹ *Annual Book of ASTM Standards*, Vol 09.01.

¹⁰ *Annual Book of ASTM Standards*, Vol 04.08.



Weight of Soils Using a Vibratory Table¹⁰
D 4254 Test Method for Minimum Index Density and Unit
Weight of Soils and Calculation of Relative Density¹⁰
2.2 *Other Standards:*
ACI Code 318 Standard Building Code Requirements for
Reinforced Concrete¹¹
AISI-C 1012¹²

3. Terminology

3.1 *Definitions*—For definitions of terms relating to concrete pipe, see Terminology C 822.

4. Classification

4.1 Pipe manufactured according to this specification shall be for hydrostatic heads of 25, 50, 75, 100, and 125 ft measured to the centerline of the pipe. Designs are provided in Table 1 for the above hydrostatic heads combined with external loadings of 5, 10, 15, and 20 ft (designated A, B, C, and D in Table 1) of earth cover over the top of the pipe under specific installation conditions. The specific installation conditions are covered in Appendix X1. Where the hydrostatic head, external loadings, and installation conditions vary from those given in Table 1 and Appendix X1, detailed design calculations should be made. The design criteria for Table 1 are presented in Appendix X2.

5. Basis of Acceptance

5.1 Acceptability of the pipe in all diameters and classes shall be determined by the results of such material tests as are required in 6.2 through 6.9 by crushing tests on cured concrete cylinders, by hydrostatic pressure tests on units of the pipe, by joint leakage tests, and by inspection during or after manufacture to determine whether the pipe conforms to this specification as to design and freedom from defects.

5.2 *Age for Acceptance*—Pipe shall be considered ready for acceptance when they conform to the requirements, as indicated by the specified tests.

6. Materials

6.1 *Reinforced Concrete*—The reinforced concrete shall consist of portland cement, mineral aggregates, and water, in which steel has been embedded in such a manner that the steel and concrete act together. Fly ash or pozzolan may be used as a partial cement replacement; see 9.1.

6.2 *Cementitious Materials:*

6.2.1 *Cement:*

6.2.1.1 *Portland Cement*—Portland cement shall conform to the requirements of Specification C 150.

6.2.1.2 *Blended Cement*—Blended cement shall conform to the requirements of Specification C 595 for Type IS portland blast furnace slag cement or Type IP portland pozzolan cement, except that the pozzolan constituent in the Type IP portland pozzolan cement shall not exceed 20 % by weight.

6.2.2 *Fly Ash or Pozzolan*—Fly ash or pozzolan shall conform to the requirements of Specification C 618.

6.2.3 *Allowable Combinations of Cementitious Materials*—The combination of cementitious materials used in the concrete shall be one of the following:

6.2.3.1 Portland cement only,

6.2.3.2 Portland blast furnace slag cement only, or

6.2.3.3 Portland pozzolan cement only.

6.2.3.4 A combination of portland cement and fly ash or pozzolan, wherein the proportion of fly ash or pozzolan is between 5 and 20 % by weight of total cementitious material (portland cement plus fly ash or pozzolan).

6.3 *Aggregates*—Aggregates shall conform to Specification C 33, except that the requirements for grading are waived.

6.4 *Admixtures*—Admixtures, except for air-entraining agents, shall not be added to the concrete unless permitted by the owner. At the option of the manufacturer, or if specified by the owner, the concrete in precast concrete pipe placed by the cast-and-vibrated method shall contain an air-entraining agent conforming to Specification C 260. The amount of air-entraining agent used shall be such as will affect the entrainment of not more than 3 % air by volume of concrete as discharged from the mixer.

6.5 *Steel Reinforcement*—Reinforcement may consist of wire conforming to Specification A 82, Specification A 496, or of wire fabric conforming to Specification A 185 or Specification A 497, or of bars of Grade 40 steel conforming to Specification A 615/A 615M.

6.6 *Steel for Joint Rings:*

6.6.1 Steel strips for bell rings less than ¼ in. thick shall conform to Grade 30 of Specification A 570/A 570M or Grade Designation 1012 of Specification A 575. Steel that meets the requirements of AISI-C1012 for chemical components will be acceptable provided it conforms to Grade 30 of Specification A 570/A 570M in other respects.

6.6.2 Steel plate for bell rings ¼ in. or more in thickness and special shapes for spigot joint rings shall conform to Specification A 36/A 36M, or to Grade A of Specification A 283/A 283M, or to Grade Designation 1012 of Specification A 576, or to Grade 50 of Specification A 675/A 675M. Steel that meets the requirements of AISI-C1012 for chemical components will be acceptable provided it conforms to Specification A 36/A 36M or to Specification A 283/A 283M in other respects.

6.7 *Steel Castings for Fittings*—Steel castings for fittings shall conform to Grade 70-36, Normalized, of Specification A 27/A 27M.

6.8 *Steel Plates and Sheets for Specials and Fittings*—Steel plates for specials and fittings shall conform to Specification A 36/A 36M or to Grade B or C of Specification A 283/A 283M or Grade 30 or 33 of Specification A 570/A 570M or Grade B of Specification A 611.

6.9 *Rubber Gaskets:*

6.9.1 *Composition and Properties*—All rubber gaskets shall be extruded or molded and cured in such a manner that any cross section will be dense, homogeneous, and free of porosity, blisters, pitting, and other imperfections. The gaskets shall be of a solid circular cross section and shall be extruded or molded

¹¹ Available from the American Concrete Institute, P.O. Box 19150, Detroit, MI 48219.

¹² Available from American Iron and Steel Institute, 1133 15th St., NW, Washington, DC 20005.



to the specified size within a diametrical tolerance of $\pm 1/64$ in. or $\pm 1.5\%$ of the diameter, whichever is larger. The basic polymer shall be natural rubber, synthetic rubber, or a blend of both. The properties enumerated below shall be determined in accordance with 10.5.

6.9.1.1 *Standard Gasket Requirements*—The compound shall meet the following for physical requirements (see also Test Methods D 412):

Tensile strength, min, psi	2300
Elongation at break, min, %	425
Shore durometer hardness, nominal:	
Min	40 ^A
Max	60 ^A
Compression set, max, % of original deflection	20
Accelerated aging, max, % of original	
Decrease in tensile strength	15
Decrease in elongation	20
Liquid immersion, max, % weight increase	
Water absorption	5
Ozone resistance	no visible cracking in accordance with Test Method D 1149

^A Allowable variation ± 5 from manufacturers' specified nominal hardness.

6.9.1.2 *Oil Resistant Gasket Requirements*—The compound shall contain not less than 50 % by volume oil resistant polymer and shall meet the following physical requirements:

Tensile strength, min, psi	1500
Elongation at break, min, %	350
Shore durometer hardness, nominal:	
Min	40 ^A
Max	60 ^A
Durometer aging, max, increase	15
Compression set, max, % of original deflection	20
Accelerated aging, max, % of original	
Decrease in tensile strength	20
Decrease in elongation	40
Liquid immersion, max, % volume change:	
Oil, in ASTM #3 (70 h at 212°F)	80
Water absorption	15
Ozone resistance, 72 h exposure in 50 PPHM ozone concentration at 104°F	no visible cracking in accordance with Test Method D 1149

^A Allowable variation ± 5 from manufacturers specified nominal hardness.

6.9.1.3 *Durometer Hardness*—The shore durometer hardness shall be in the range of from 35 to 50 for concrete spigots and 35 to 65 for steel spigots where the range includes the allowable variation as given in 6.9.1.1 and 6.9.1.2.

6.9.2 *Storage*—All rubber shall be stored in as cool a place as practicable, preferably at 70°F or less, and in no case shall the rubber for joints be exposed to the direct rays of the sun for more than 72 h.

6.10 *Gasket Lubricants:*

6.10.1 Where the joint design utilizing a rubber gasket dictates the use of a lubricant to facilitate assembly, the lubricant composition shall have no detrimental effect on the performance of the gasket and joint due to prolonged exposure.

6.10.2 *Storage*—The lubricant shall be stored in accordance with the lubricant manufacturer's recommended temperature range.

6.10.3 *Certification*—When requested by the owner, the manufacturer shall furnish written certification that the joint lubricant conforms to all requirements of this specification for the specific gaskets supplied.

6.10.4 *Marking*—The following information shall be clearly marked on each container of lubricant.

6.10.4.1 Name of lubricant manufacturer.

6.10.4.2 Usable temperature range for application and storage.

6.10.4.3 Shelf life.

6.10.4.4 Lot or batch number.

7. Design

7.1 *Design Tables*—The diameter, wall thickness, compressive strength of the concrete, and the area of circumferential reinforcement shall be as prescribed for the classes of combined hydrostatic head and external loading given in Table 1 subject to the provisions of 7.2, 7.4, 7.5, 10.3, 11.1, 11.2, and 11.5.

7.2 *Modified and Special Design*—Manufacturers may submit to the owner, for approval prior to manufacture, detailed designs for loading or installation conditions other than those shown in Table 1. Such pipe must meet all of the tests and performance requirements specified by the owner in accordance with Section 5.

7.3 *Laying Lengths*—The maximum laying lengths of pipe units that will be acceptable are as follows and are subject to the provisions of 11.4:

Internal Diameter of Pipe, in.	Maximum Laying Length of Pipe, ft
12 to 15	12
18	14
21 to 24	16
27 to 30	18
33 to 36	20
39 and larger	24

7.4 *Placement of Reinforcement*—The circumferential reinforcement shall be a single-cage circular, double-cage circular, or elliptical cage as shown in Table 1. Elliptical reinforcement will be permitted for 25 and 50-ft head classes only and only in pipe 18 to 72 in. in diameter, inclusive. All pipe with a wall thickness of less than $3/4$ in. shall be reinforced with either a circular cage or a single elliptical cage of steel as provided in Table 1. All pipe with wall thickness of $3/4$ in. and greater shall be reinforced with either two separate cages or a single elliptical cage of steel as provided in Table 1, except that for pipe sizes 36 in. and less with wall thicknesses equal to or greater than $3/4$ in., a single circular cage may be accepted if the steel area is equal to or greater than the least area shown for a single circular cage for that particular class of pipe. The areas of circumferential reinforcement shown in Table 1 are the design requirements for each of the wall thicknesses shown in the table. Where single-cage circular reinforcement is used, the center-line of the reinforcement shall be placed from 40 to 50 % of the wall thickness from the inner surface of the pipe, provided that the minimum concrete cover specified below shall be maintained. Where two separated circular cages of reinforcement are used, the inner and outer cages shall be placed so that the concrete cover, measured radially, over the circumferential reinforcement will be as follows:

Pipe Diameter, in.	Minimum Cover, in.	Maximum Cover, in.
45 and less	$3/4$	1
48 through 60	$3/4$	$1\frac{1}{8}$
63 through 69	$3/4$	$1\frac{1}{4}$
72 through 108	1	$1\frac{1}{2}$

7.4.1 These limits on minimum and maximum cover are applicable to elliptical steel at the horizontal and vertical axes



of the pipe. The circumferential reinforcement at each end of the pipe unit shall consist of one complete coil or ring in which the end is lapped or welded as prescribed in 7.6. The clear distance of the end coil or ring shall not be less than $\frac{1}{2}$ in. or more than 1 in. from the end of the pipe unit, except this requirement does not apply to the inner layer of circumferential reinforcement in joints utilizing steel bell and spigot rings, provided that the clear distance restrictions will not apply for a distance of 20 bar diameters measured circumferentially from the end of the lap or weld.

7.4.2 A cage of circumferential reinforcement with Table 1 areas greater than $0.45 \text{ in.}^2/\text{linear ft}$ of pipe may be composed of two layers of reinforcement, and cage areas greater than $0.90 \text{ in.}^2/\text{linear ft}$ of pipe may be composed of three layers. The layers shall not be separated by more than the thickness of one longitudinal plus $\frac{1}{4}$ in. The layers shall be fastened together to form a single rigid cage. Where inner and outer cages are used, the minimum clear spacing between the two cage systems shall be 0.25 times the wall thickness. All other specification requirements such as laps, welds, concrete cover, and tolerances of placement in the wall of the pipe, etc., shall apply to this method for fabrication of a cage of reinforcement.

7.5 *Longitudinal Reinforcement*—Each layer of circumferential reinforcement shall be assembled into a rigid cage supported by longitudinal bars that extend the full length of the pipe. The minimum concrete cover for longitudinal steel shall be $\frac{1}{2}$ in. except that the longitudinal bars or rods may extend to either or both ends of the pipe unit to form supports for holding the circumferential cage in proper position. Not less than four longitudinal bars at approximately equal spacing shall be provided for each cage, and additional bars shall be provided as necessary so that the circumferential spacing between longitudinal bars shall not exceed 42 in. in any cage. Where the pipe joint construction requires the use of a bell, the minimum number of longitudinal bars shall be provided in the bell and may be continuous bars or spliced to the main longitudinal bars. The circumferential bars of each cage shall be spaced and supported by welding or tying each hoop to the longitudinal bars. Spacer bars, chairs, or other methods shall be provided to maintain the reinforcement cage or cages in proper position within the forms during the placement and consolidation of the concrete. The spacer bars or chairs may extend to the finished concrete surfaces of the pipe.

7.6 *Laps, Welds, and Spacing*—If the splices are not welded, the reinforcement shall be lapped not less than 20 diameters for deformed bars and deformed cold-worked wire, and 40 diameters for plain bars and cold-drawn wire. In addition, where lapped cages of welded wire fabric are used without welding, the lap shall contain a longitudinal wire. Lapped or butt welded splices shall develop a tensile strength of not less than 40 000 psi based on the nominal cross-sectional area of the bar or wire. Lapped welds shall have a minimum lap of 2 in. The spacing center-to-center of adjacent rings of circumferential reinforcement in a cage shall not exceed 4 in. The continuity of the circumferential reinforcing steel shall not be destroyed during the manufacture of the pipe.

8. Joints

8.1 Joints may utilize steel joint rings, steel bells and

concrete spigots, or be formed entirely of concrete. Joint assemblies shall be so formed and accurately manufactured that when the pipes are drawn together the pipe shall form a continuous watertight conduit with a smooth and uniform interior surface and shall provide for slight movements of any pipe unit in the pipeline due to expansion, contraction, settlement, or lateral displacement. The rubber gasket shall be the sole element of the joint depended upon to provide watertightness. The joint shall be so designed that the gaskets will not be required to support the weight of the pipe, but will keep the joint tight under all normal conditions of service. The ends of the pipe shall be in planes at right angles to the longitudinal centerline of the pipe, except where bevel-end pipe for deflections up to 5° is specified or indicated for bends.

8.2 Joints utilizing collars instead of bells cast as an integral part with the pipe barrel shall comply with the requirements for bell-and-spigot joints given in 8.4.1 through 8.4.8. The collar shall be flared at each end to facilitate entrance of the gasket when closing the joint. The straight section between the flares at either end shall be a true cylinder of such length that at the position of normal joint closure, the parallel surfaces upon which the gasket may bear during closure will extend not less than $\frac{3}{4}$ in. away from the edges of the gasket. Each end of the pipe shall have a groove formed on its outer surface of suitable dimensions to contain a circular rubber gasket.

8.3 Joints utilizing steel bell-and-spigot rings shall comply with the requirements for bell-and-spigot joints given in 8.4.1, 8.4.3, and 8.4.5. The bell ring shall have a minimum thickness of $\frac{3}{16}$ in. and width sufficient to provide for adequate embedment in the pipe. It shall be flared at one end and may be tapered at the other end. The remainder of the bell ring shall be a true cylinder of such length that at the position of normal joint closure, the parallel surface upon which the gasket may bear during the closure will extend not less than 1 in. away from the edge of the gasket. The spigot ring shall be formed from a specially shaped section of steel with a groove of suitable dimensions to contain a circular rubber gasket. The difference in circumference of the inside of the bell ring and the outside of the spigot ring shall not exceed $\frac{3}{16}$ in. for gaskets of $\frac{21}{32}$ -in. diameter or less, and $\frac{1}{4}$ in. for gaskets greater than $\frac{21}{32}$ -in. diameter.

8.4 In pipe utilizing bell-and-spigot joints, the joint shall be designed and manufactured so that the spigot and gasket will readily enter the bell of the pipe. In all-concrete joints the manufacturer shall provide sufficient reinforcement in the bell to resist the hydrostatic, hydrodynamic, and gasket pressures. The shape and dimensions of the joint shall be such as to provide the minimum requirements given in 8.4.1 through 8.4.8.

8.4.1 The rubber gaskets shall be solid gaskets of circular cross section and shall be confined in an annular space formed by shoulders on the bell and spigot or in a groove in the spigot of the pipe so that movement of the pipe or hydrostatic and hydrodynamic pressure cannot displace the gasket. When the joint is assembled, the gasket shall be compressed to form a watertight seal.

8.4.2 In joints that utilize spigot grooves, the volume of the annular space provided for the gasket, with the engaged joint at



normal joint closure in concentric position, and neglecting ellipticity of the bell and spigot, shall be not less than the design volume of the gasket furnished. The cross-sectional area of the annular space shall be calculated for minimum bell diameter, maximum spigot diameter, minimum width of groove at surface of spigot, and minimum depth of groove. The volume of the annular space shall be calculated considering the centroid of the cross-sectional area to be at the midpoint between the inside bell surface and the surface of the groove on which the gasket is seated at the centerline of the groove.

8.4.3 In joints that utilize spigot grooves, if the average volume of the gasket furnished is less than 75 % of the volume of the annular space in which the gasket is to be contained with the engaged joint at normal joint closure in concentric position, the gasket shall not be stretched more than 20 % of its unstretched length when seated on the spigot or not more than 30 % if the design volume of the gasket is 75 % or more of the volume of the annular space. For determining the volume of the annular space, the cross-sectional area of the annular space shall be calculated for average bell diameter, average spigot diameter, average width of groove at surface of spigot, and average depth of groove. The volume of the annular space shall be calculated considering the centroid of the cross-sectional area to be at the midpoint between the inside bell surface and the surface of the groove on which the gasket is seated at the centerline of the groove. It is further specified that when the design volume of the gasket is less than 75 % of the volume of the annular space, as calculated above, the gasket shall be of such diameter that when the outer surface of the spigot and the inner surface of the bell come into contact at some point in their periphery, the deformation in the gasket shall not exceed 40 % at the point of contact nor be less than 15 % at any point. If the design volume of the gasket is 75 % or more of the volume of the annular space, the deformation of the gasket, as prescribed above, shall not exceed 50 % nor be less than 15 %. When determining the maximum percent deformation of the gasket, the maximum groove width, the minimum depth of groove, and the stretched gasket diameter shall be used and calculations made at the centerline of the groove. When determining the minimum percent deformation of the gasket, the minimum groove width, the maximum bell diameter, the minimum spigot diameter, the maximum depth of groove, and the stretched gasket diameter shall be used and calculations made at the centerline of the groove. For gasket deformation calculations, stretched gasket diameter shall be determined as being the design diameter of the gasket divided by the square root of $(1 + x)$ where x equals the design percent of gasket stretch divided by 100.

8.4.4 In joints that utilize shoulders on the bell and spigot to confine the gasket, the gasket shall not be stretched more than 20 % of its unstretched length when seated on the spigot. It is further specified that the gasket shall be of such diameter that when the outer surface of the spigot and the inner surface of the bell come into contact at some point in their periphery, the deformation in the gasket shall not exceed 40 % at the point of contact nor be less than 15 % at any point. When determining the maximum percent deformation of the gasket, the minimum depth of shoulders and the stretched gasket diameter shall be

used. When determining the minimum percent deformation of the gasket, the maximum depth of shoulders, the maximum bell diameter, the minimum spigot diameter, and the stretched gasket diameter shall be used. For gasket deformation calculations, the stretched diameter shall be determined as described for joints that utilize spigot grooves.

8.4.5 Each gasket shall be manufactured to provide the volume of rubber required by the pipe manufacturer's joint design with a tolerance of $\pm 3\%$ for gaskets up to and including $\frac{1}{2}$ in. in diameter and $\pm 1\%$ for gaskets of 1-in. diameter and larger. The allowable percentage tolerance shall vary linearly between $\pm 3\%$ and $\pm 1\%$ for gasket diameters between $\frac{1}{2}$ and 1 in.

8.4.6 The tolerances permitted in the construction of the joint shall be those stated in the pipe manufacturer's design as approved.

8.4.7 The taper on all surfaces of the bells and spigots, on which the rubber gasket may bear during closure of the joint and at any degree of partial closure, except within the gasket groove, shall form an angle of not more than 2° with the longitudinal axis of the pipe. The joint shall be so designed and manufactured that at the position of normal joint closure, the parallel surfaces upon which the gasket may bear during closure will extend not less than $\frac{3}{4}$ in. away from the edges of the gasket.

8.4.8 The surfaces of the bell and spigot in contact with the gasket, and adjacent surfaces that may come in contact with the gasket within a joint movement range, shall be free from airholes, chipped or spalled concrete, laitance, or other defects. The inside surface of the bell adjacent to the bell face shall be flared to facilitate joining the pipe sections without damaging or displacing the gasket.

8.5 *Alternative Joint Designs*—If permitted by the owner, manufacturers may submit to the owner, detailed designs for joints and gaskets other than those described in Section 8. Design submissions shall include joint geometry, tolerances, gasket characteristics, proposed plant tests, gasket splice bend tests, and such other information as required by the owner to evaluate the joint design for field performance. Joints and gaskets of alternate joint designs shall meet all test requirements of this specification and shall maintain at least 15 % deformation of the rubber gasket when out-of-roundness and off-center position of the joint is considered. Alternative joint designs shall be acceptable provided the designs are approved by the owner prior to manufacture and provided the test pipe comply with the specified tests.

9. Materials and Manufacture

9.1 *Concrete Mixture*—The aggregates shall be graded, proportioned, and thoroughly mixed in a batch mixer with the proportions of cementitious materials and water that will produce a workable, uniform, homogeneous concrete mixture of such quality that the pipe will conform to the test and design requirements of this specification. Batching shall be accomplished by weighing. If the concrete materials are weighed accumulatively, the cementitious materials shall be weighed before the other ingredients. Cementitious materials shall be as specified in 6.2 and shall be added to the mix in a proportion not less than 564 lb/yd³.



9.1.1 *Placement of Concrete*—The transporting and placement of concrete shall be by methods that will prevent separation of the concrete materials and the displacement of the reinforcement steel from its proper position in the form.

9.2 *Curing of Pipe*—The method and extent of curing shall be established by testing not less than five cylinders cured in the same manner as the pipe until they have attained an average strength of 3600 psi. After a satisfactory curing method and period have been established, they shall not be changed without approval of the owner. If required by the owner, each day's run of pipe shall be cured until a companionate test cylinder cured in the same manner as the pipe has attained a strength of 3600 psi. Pipe shall be protected from temperatures below 40°F from the time the concrete is placed until the curing period is completed. Curing may be by any other method or combination of methods described below or by any other method approved by the owner.

9.2.1 *Steam Curing*—After the pipe has been cast, it shall be placed in an enclosure of such nature as to protect the pipe from outside drafts and to allow full circulation of saturated vapor around the inside and outside of the pipe. The rise in the ambient temperature shall not exceed 40°F in any 1 h; nor shall the ambient temperature exceed 100°F during the 2 h immediately following concrete placement. At no time shall the ambient temperature exceed 150°F. Following the periods of steam curing, the pipe shall be protected from rapid drops in temperature, which may injure the pipe.

9.2.2 *Water Curing*—Concrete in pipe may be water-cured by any method that will keep the pipe moist during the curing period.

9.2.3 *Membrane Curing*—The sealing compound used for membrane curing shall conform to the requirements of Specification C 309. The pipe surfaces shall be kept moist prior to application of the compound, and at the time of application the surfaces shall be moist and the temperature of the concrete shall be within 10°F of the atmospheric temperature. If the membrane is damaged, it shall be repaired immediately with additional compound.

10. Physical Properties

10.1 *Test Specimens*—The specified number of pipe required for the tests shall be furnished without charge by the manufacturer and shall be selected at random by the owner, and shall be pipe that would not otherwise be rejected under this specification. The selection shall be made at the point or points designated by the owner when placing the order. Pipe units that satisfactorily pass the required tests shall be acceptable for use.

10.2 *Number and Type of Test Required for Various Delivery Schedules:*

10.2.1 *Preliminary Tests for Extended Delivery Schedules*—An owner of pipe, whose needs require shipments at intervals over extended periods of time, shall be entitled to such tests, preliminary to delivery of pipe, as are required in Section 5, of not more than three sections of pipe covering each size in which he is interested. The strength of concrete shall be determined from test cylinders made from the concrete used in making the pipe as provided in 10.3.

10.2.2 *Additional Tests for Extended Delivery Schedules*—After the preliminary tests described in 10.2.1 an owner shall

be entitled to additional tests in such numbers and at such times as he may deem necessary, provided that the total number of pipe shall not exceed 1 % of each size and class of pipe manufactured in each test period, except that at least one hydrostatic and joint leakage test shall be made for each size and class.

10.2.3 *Length of Test Period*—For the purpose of testing the pipe units, the length of the test period will be set at the number of days the plant of the pipe manufacturer is normally operated in a calendar week. The test period will include any shutdown of the plant that does not exceed a 24-h period due to failure of the plant or equipment. The length of the test period may be reduced, at the discretion of the owner if there is a significant change in the materials used in the pipe, in the mix proportions, or in the production procedures or by numerous shutdowns of the plant due to failures of the plant or equipment. The length of the test period may be increased at the discretion of the owner when results of tests for successive periods indicate that the manufacturer's operations are productive of uniformly acceptable pipe.

10.3 Concrete Strength:

10.3.1 *Compressive Strength*—Compression tests for satisfying the design concrete strength shall be made on cured concrete cylinders. The concrete shall have a minimum crushing strength as specified in 10.3.3. Compression tests of such cylinders shall be made in accordance with Test Method C 39.

10.3.2 *Number of Compression Tests*—At least five standard test cylinders shall be prepared from each day's production of concrete. Test cylinders shall be prepared in conformance with Practice C 31, except that the cylinders may be prepared by methods comparable to those used to consolidate and cure concrete in the actual pipe manufactured, or for concrete of a consistency too stiff for compaction by rodding or internal vibration, the alternative method described in the cylinder strength test method section of Test Methods C 497 may be used.

10.3.3 *Compression Test Requirements*—The average 28-day compressive strength of all cylinders tested shall be equal to or greater than the design strength of the concrete. Not more than 10 % of the cylinders tested shall fall below the design strength. In no case shall any cylinder tested fall below 80 % of the specified design strength. These compressive strength requirements refer to standard 6 by 12-in. concrete test cylinders. Where the strength of 6 by 12-in. concrete test cylinders exceeds the capacity of the normal field testing machine (200 000 lbf), 3 by 6-in. test cylinders will be permitted with correction for size of cylinder.

10.4 Hydrostatic Tests:

10.4.1 *Hydrostatic Testing of Pipe*—Hydrostatic tests on pipe shall be made in accordance with the provisions of Test Methods C 497. Before the test pressure is applied, the pipe may be allowed, at the option of the manufacturer, to stand under reduced pressure, but not for more than 48 h. Acceptance hydrostatic tests shall be made to 120 % of the specified internal working pressure for which the pipe is designed. The pipe shall withstand the percentage of working pressure prescribed above for at least 20 min without cracking and with



no leakage appearing on the exterior surface. Moisture appearing on the surface of the pipe in the form of patches or beads adhering to the surface will not be considered as leakage. Slow-forming beads of water that result in minor dripping which can be proven to seal and dry up upon retesting under the prescribed test pressure will be considered acceptable.

10.4.2 Hydrostatic Testing of Rubber Gasket Joints—Hydrostatic pressure tests on joints shall be made on joints assembled of two sections of pipe, properly connected in accordance with the joint design. Suitable bulkheads may be provided with the pipe adjacent to and on either side of the joint, or the manufacturer may bulkhead the outer ends of joined pipe sections and conduct hydrostatic tests on both the pipe and pipe joint concurrently. No mortar or concrete coatings, fillings, or packings shall be placed prior to watertightness tests. After the pipe sections are fitted together with the rubber gasket or gaskets in place, the watertightness of the joints shall be tested under hydrostatic heads of 120 % of the pressure for which the pipe is designed, and there shall be no water leakage through the rubber gasket joint. On completion of the above straight alignment tests, the assembly shall be loaded to cause maximum joint annular space to occur. The load shall be applied such that a minimum differential load across the non-bulkheaded joint of 150 lb per inch of diameter is obtained or concrete to concrete contact occurs. The assembly shall then be retested as set forth in 10.4.1 and 10.4.2.

10.4.3 Retests of Pipe or Pipe Joints Not Meeting the Hydrostatic Test Requirements—In the event that a pipe or pipe joint fails the required tests, the manufacturer shall have the right to test two other sections of the pipe selected by the owner from the same period's run from which the original was selected. If these two pipe successfully pass the test, the remainder of the pipe in that period's run will be accepted. If either of these pipe fails, the remainder in that period's run will not be accepted until each pipe has satisfactorily passed this test.

10.5 Rubber Gasket Compound:

10.5.1 Test Methods—Laboratory tests to determine the physical properties of the rubber gaskets to be furnished under this specification shall be performed on test specimens taken from the finished rubber product, except that at the option of the pipe manufacturer specimens may be furnished in accordance with the appropriate ASTM method.

10.5.1.1 Tensile Strength and Elongation— Test Methods D 412.

10.5.1.2 Hardness—Test Method D 2240 (with the exception of the Summary of Test Methods Section). The determination shall be taken directly on the gasket. The presser foot shall be applied on areas that are ¼ in. or greater in thickness. If ¼ in. or greater in thickness is not available in the gasket, thinner samples may be plied up to obtain this thickness.

10.5.1.3 Compression Set—The Compression Set under Constant Deflection in Air Method of Test Methods D 395. The specimens shall be a ½ in. long section of gasket with a minimum diameter of ½ in., deflected axially. Test conditions shall be 22 h at 158°F.

10.5.1.4 Accelerated Aging—Test Method D 573. Test conditions shall be 96 h at 158°F.

10.5.1.5 Water Absorption—Test Method D 471. Use distilled water for the standard test liquid. When a 1-in. wide test specimen cannot be obtained, use the greatest width obtainable from the test sample. Test conditions shall be 48 h at 158°F.

10.5.1.6 Splices—If a splice is used in the manufacture of the gasket, the strength shall be such that the gasket shall withstand 100 % elongation over the part of the gasket that includes the splice with no visible separation of the splice. While in the stretched position, the gasket shall be rotated in the spliced area a minimum of 180° in each direction in order to inspect for separation. Any portion of the splice shall be capable of passing a bend test without visible separation. The bend test for circular gaskets is defined as wrapping the portion of the unstretched gasket containing the splice a minimum of 180° and a maximum of 270° around a rod of a diameter equal to the cross section diameter of the gasket.

10.5.1.7 Ozone Resistance—Determine the resistance to ozone in accordance with Test Method D 1149. Specimens shall be the test specimen of the finished gasket cross-section. Conduct test for 72 h in 50 PPHM at 104 ± 4°F with specimens stressed to 20 % extension.

10.5.2 Test Reports—The manufacturer shall, if required, furnish certified copies of test reports of the rubber compound used in all rubber gaskets.

10.6 Test Equipment—Every manufacturer furnishing pipe under the specifications shall furnish all facilities and personnel necessary to carry out the tests described in this specification.

11. Permissible Variations

11.1 Internal Diameter—Variations of the internal diameter of the pipe shall not exceed ±1.5 % for pipe having internal diameters 12 to 24 in., inclusive, and ±0.75 % or ⅜ in., whichever is larger, for pipe having internal diameters over 24 to 108 in., inclusive. In order to obtain continuity of the interior surfaces of the pipeline, the maximum offset at the joints shall not exceed 0.75 % of the internal diameter of the pipe.

11.2 Wall Thickness—The wall thickness shall be not less than that intended in the design by more than 5 % at any point.

11.3 Length of Two Opposite Sides—Variations in laying lengths (see *L* in Figs. 1 and Figs. 2 of Test Methods C 497) of two opposite sides of pipe shall not be more than ⅛ in./ft of diameter, with a maximum of ⅝ in. in any length of pipe, except where beveled-end pipe for laying on curves is specified by the owner.

11.4 Length of Pipe—The underrun or overrun in length of a section of pipe shall not be more than ⅛ in./ft with a maximum of ½ in. in any length of pipe.

11.5 Area of Reinforcements—The area of steel reinforcement shall be not less than 97 % of the design steel area of each cage ring. Steel areas greater than those required in the design shall not be cause for rejection.

11.6 The average diameter of any bell or spigot shall be within the minimum and maximum limits used in Section 8 (except 8.3 for design of the joint). The average diameter of a bell will be determined by taking the average of four equally spaced diametric measurements. The average spigot diameter will be determined by dividing the measured circumference by 3.1416.

11.6.1 An additional tolerance referred to as “inspection”



tolerance is allowed during inspection of completed pipe units. This tolerance quantitatively is two times the minimum design joint clearance. The minimum design joint clearance is one half of the difference between the maximum design spigot diameter and the minimum design bell diameter. This “inspection” tolerance shall be apportioned to the bell and to the spigot in a ratio elected by the manufacturer. This tolerance, when applied, defines the minimum acceptable bell diameter on any pipe unit, measured diametrically, to be the minimum design bell diameter minus that part of the “inspection” tolerance apportioned to the bell. Similarly, the maximum acceptable spigot diameter on any pipe unit, measured diametrically, is defined to be the maximum design spigot diameter plus that part of the “inspection” tolerance apportioned to the spigot.

12. Workmanship, Finish, and Appearance

12.1 Pipe shall be substantially free of fractures, excessive surface crazing, pits, air holes, laitance, excessive brush marks, and interior surface roughness.

13. Repairs

13.1 Pipe may be repaired if made necessary because of imperfections in manufacture or damage during handling, and will be considered acceptable if, in the opinion of the owner, the defects do not subject the pipe unit to rejection as specified in Section 15, and the repairs are sound and properly finished and cured. Air holes in the gasket-bearing area may be repaired. Such fillings shall be kept moist under wet burlap for at least 48 h. Hydrostatic testing of repaired pipe may be required if deemed necessary by the owner, and such testing shall be at no additional cost to the owner.

14. Inspection

14.1 The quality of all materials, the process of manufacture, and the finished pipe shall be subject to inspection and approval by the owner.

15. Rejection

15.1 Pipe shall be subject to rejection on account of failure to conform to any of the specification requirements or on account of any of the following:

15.1.1 Defects that indicate any imperfect mixing and molding not in compliance with 9.1,

15.1.2 Surface defects indicating honeycombed or open texture, and

15.1.3 Damaged ends where such damage would prevent making a satisfactory joint.

16. Product Marking

16.1 The following shall be legibly marked on the interior surface of the pipe:

16.1.1 Specification designation, class, and size as indicated in Table 1,

16.1.2 Date of manufacture,

16.1.3 Name or trademark of the manufacturer, and

16.1.4 One end of each section of pipe with elliptical reinforcement shall be clearly marked, during the process of manufacturing or immediately thereafter, on the inside and the outside of opposite walls along the minor axes of the elliptical reinforcing. Markings shall be indented on the pipe section or painted thereon with waterproof paint.

**NOTICE: This standard has either been superseded and replaced by a new version or discontinued.
Contact ASTM International (www.astm.org) for the latest information.**

TABLE 1 Design Requirements for Reinforced Concrete Low-Head Pressure Pipe^A [12 Through 108 in. Diameter], Concrete Design Strength 4500 psi

NOTE 1—See Appendix for specific installation conditions and design criteria conditions required in conjunction with the use of Table 1.

NOTE 2—Designations, A, B, C, and D, for class of pipe, denote 5, 10, 15, and 20 ft of earth cover over top of pipe. Figures 25, Figures 50, Figures 75, etc. for class of pipe, denote hydrostatic pressure heads in feet measured to centerline of pipe.

Internal Designated Dia, in.	Circumferential reinforcement, in. ² /linear ft of pipe ^B																							
	12		15		18				21				24				27							
	Circular		Circular		Circular		Elliptical		Circular		Elliptical		Circular		Elliptical		Circular				Elliptical			
	2	3	2	3	2¼	3	2¼	3	2½	3	2¾	3	2½	3	2½	3	2½	3½	¾		¼		2½	¾
Layers of Reinforcement	Single	Single	Single	Single	Single	Single	Single	Single	Single	Single	Single	Single	Single	Single	Single	Single	Single	Single	Inner	Outer	Inner	Outer	Single	Single
Class																								
A-25	0.07	0.06	0.10	0.08	0.12	0.11	0.12	0.12	0.15	0.13	0.14	0.14	0.18	0.16	0.16	0.16	0.21	0.19	0.13	0.09	0.11	0.07	0.18	0.18
B-25	0.10	0.08	0.14	0.11	0.18	0.15	0.16	0.12	0.23	0.19	0.20	0.14	0.29	0.25	0.23	0.18	0.35	0.30	0.20	0.11	0.15	0.08	0.27	0.20
C-25	0.13	0.09	0.19	0.14	0.25	0.19	0.22	0.14	0.32	0.26	0.27	0.19	0.40	0.33	0.32	0.24	0.49	0.41	0.27	0.14	0.20	0.09	0.39	0.27
D-25	0.16	0.11	0.25	0.17	0.32	0.24	0.28	0.17	0.42	0.33	0.37	0.23	0.54	0.43	0.44	0.30	...	0.54	0.35	0.16	0.24	0.10	0.51	0.35
A-50	0.11	0.10	0.14	0.13	0.18	0.16	0.24	0.24	0.21	0.19	0.28	0.28	0.25	0.23	0.32	0.32	0.29	0.27	0.19	0.15	0.16	0.12	0.36	0.36
B-50	0.13	0.11	0.19	0.15	0.23	0.20	0.24	0.24	0.29	0.26	0.28	0.28	0.36	0.32	0.32	0.32	0.43	0.38	0.26	0.17	0.20	0.13	0.36	0.36
C-50	0.16	0.13	0.24	0.18	0.30	0.25	0.26	0.24	0.38	0.32	0.32	0.28	0.47	0.40	0.39	0.32	0.57	0.49	0.32	0.19	0.25	0.14	0.45	0.36
D-50	0.19	0.15	0.29	0.21	0.37	0.29	0.33	0.24	0.48	0.39	0.42	0.28	0.61	0.50	0.50	0.37	...	0.61	0.41	0.22	0.29	0.15	0.58	0.41
A-75	0.17	0.17	0.21	0.21	0.26	0.26	0.30	0.30	0.34	0.34	0.38	0.38	0.25	0.20	0.21	0.17
B-75	0.17	0.17	0.23	0.21	0.29	0.26	0.35	0.32	0.43	0.39	0.50	0.46	0.31	0.23	0.25	0.18
C-75	0.20	0.17	0.28	0.23	0.35	0.30	0.44	0.38	0.54	0.47	0.65	0.57	0.39	0.25	0.30	0.19
D-75	0.23	0.18	0.34	0.26	0.43	0.35	0.55	0.45	0.68	0.57	0.69	0.46	0.27	0.35	0.20
A-100	0.25	0.25	0.32	0.32	0.38	0.38	0.44	0.44	0.50	0.50	0.57	0.57	0.31	0.26	0.29	0.24
B-100	0.25	0.25	0.32	0.32	0.38	0.38	0.44	0.44	0.50	0.50	0.58	0.57	0.38	0.28	0.31	0.23
C-100	0.25	0.25	0.32	0.32	0.41	0.38	0.50	0.44	0.61	0.55	0.73	0.65	0.45	0.30	0.35	0.24
D-100	0.26	0.25	0.38	0.32	0.48	0.40	0.61	0.51	0.75	0.64	0.77	0.52	0.33	0.40	0.25
A-125	0.32	0.32	0.39	0.39	0.47	0.47	0.55	0.55	0.63	0.63	0.71	0.71	0.40	0.31	0.38	0.32
B-125	0.32	0.32	0.39	0.39	0.47	0.47	0.55	0.55	0.63	0.63	0.71	0.71	0.44	0.35	0.40	0.31
C-125	0.32	0.32	0.39	0.39	0.47	0.47	0.57	0.55	0.68	0.63	0.81	0.72	0.50	0.37	0.41	0.30
D-125	0.32	0.32	0.42	0.39	0.53	0.47	0.67	0.57	0.82	0.71	0.85	0.57	0.40	0.45	0.30





TABLE 1 Continued

Internal Designated Dia. in.	Circumferential reinforcement, in. ² /linear ft of pipe ^B																					
	36						39 ^C						42									
	Circular						Circular						Elliptical									
Type of Reinforcement	3/4			4			5			3 1/2			4			3 1/2		4 1/4				
Wall Thickness, in.	Inner	Outer	Inner	Inner	Outer	Inner	Inner	Outer	Inner	Outer	Inner	Outer	Inner	Outer	Inner	Outer	Inner	Outer	Inner	Outer		
	Single	Inner	Outer	Inner	Outer	Inner	Inner	Outer	Inner	Outer	Inner	Outer	Inner	Outer	Inner	Outer	Inner	Outer	Inner	Outer	Single	
Layers of Reinforcement	Single	Inner	Outer	Inner	Outer	Inner	Inner	Outer	Inner	Outer	Inner	Outer	Inner	Outer	Inner	Outer	Inner	Outer	Inner	Outer	Single	
Class	0.31	0.21	0.14	0.17	0.12	0.19	0.24	0.47	0.47	0.47	0.47	0.47	0.47	0.47	0.47	0.47	0.47	0.47	0.47	0.47	0.47	
A-25	0.53	0.36	0.20	0.27	0.15	0.22	0.38	0.27	0.38	0.27	0.38	0.27	0.38	0.27	0.38	0.27	0.38	0.27	0.38	0.27	0.38	
B-25	...	0.49	0.26	0.37	0.19	0.28	0.52	0.37	0.52	0.37	0.52	0.37	0.52	0.37	0.52	0.37	0.52	0.37	0.52	0.37	0.52	
C-25	...	0.67	0.33	0.46	0.23	0.35	0.72	0.46	0.70	0.46	0.70	0.46	0.70	0.46	0.70	0.46	0.70	0.46	0.70	0.46	0.70	
D-25	0.41	0.29	0.22	0.24	0.19	0.21	0.47	0.47	0.30	0.23	0.26	0.20	0.23	0.18	0.51	0.51	0.51	0.51	0.51	0.51	0.51	
A-50	0.64	0.43	0.28	0.35	0.22	0.29	0.47	0.47	0.45	0.29	0.37	0.24	0.31	0.20	0.51	0.51	0.51	0.51	0.51	0.51	0.51	
B-50	...	0.56	0.33	0.43	0.26	0.35	0.62	0.47	0.59	0.36	0.47	0.28	0.38	0.22	0.59	0.51	0.64	0.38	0.50	0.30	0.42	
C-50	...	0.74	0.41	0.53	0.29	0.41	0.80	0.53	0.77	0.43	0.57	0.32	0.46	0.24	0.77	0.57	0.81	0.46	0.63	0.35	0.50	
D-50	0.52	0.37	0.29	0.31	0.26	0.28	0.47	0.47	0.39	0.31	0.34	0.27	0.30	0.24	0.41	0.41	0.41	0.33	0.36	0.29	0.33	
A-75	0.74	0.51	0.36	0.41	0.29	0.35	0.53	0.47	0.53	0.38	0.45	0.31	0.38	0.27	0.56	0.56	0.56	0.40	0.47	0.33	0.41	
B-75	...	0.66	0.42	0.50	0.32	0.41	0.62	0.47	0.69	0.44	0.54	0.36	0.45	0.29	0.72	0.72	0.72	0.46	0.58	0.38	0.50	
C-75	...	0.81	0.49	0.61	0.37	0.49	0.80	0.53	0.84	0.51	0.66	0.40	0.53	0.32	0.88	0.88	0.88	0.54	0.70	0.43	0.58	
D-75	0.75	0.45	0.38	0.42	0.34	0.38	0.53	0.47	0.47	0.40	0.46	0.36	0.42	0.34	0.50	0.50	0.50	0.42	0.49	0.40	0.45	
A-100	0.85	0.58	0.44	0.48	0.37	0.42	0.62	0.47	0.63	0.46	0.52	0.39	0.45	0.34	0.66	0.66	0.66	0.48	0.55	0.42	0.48	
B-100	...	0.73	0.49	0.57	0.40	0.48	0.72	0.46	0.77	0.52	0.63	0.43	0.52	0.36	0.80	0.80	0.80	0.55	0.67	0.46	0.56	
C-100	...	0.88	0.56	0.68	0.44	0.54	0.80	0.53	0.92	0.59	0.73	0.47	0.59	0.38	0.99	0.99	0.99	0.63	0.78	0.50	0.65	
D-100	0.94	0.53	0.45	0.52	0.43	0.51	0.72	0.46	0.56	0.47	0.56	0.47	0.55	0.47	0.60	0.60	0.60	0.50	0.60	0.50	0.59	
A-125	0.95	0.68	0.51	0.56	0.44	0.52	0.72	0.46	0.71	0.54	0.61	0.47	0.57	0.45	0.74	0.74	0.74	0.57	0.64	0.50	0.61	
B-125	...	0.81	0.57	0.66	0.47	0.54	0.80	0.53	0.84	0.62	0.70	0.50	0.59	0.43	0.88	0.88	0.88	0.64	0.75	0.54	0.65	
C-125	...	0.99	0.65	0.75	0.51	0.62	0.80	0.53	1.03	0.68	0.80	0.54	0.67	0.45	1.07	1.07	1.07	0.71	0.86	0.58	0.72	
D-125



TABLE 1 Continued

Internal Designated Dia., in.	Circumferential reinforcement, in. ² /linear ft of pipe ^b																										
	45 ^c						48						51 ^c														
	Circular			Elliptical			Circular			Elliptical			Circular		Elliptical												
Wall Thickness, in.	3/8		4/8		5 3/4		3/8		4 3/4		5		4 1/4		5		4 1/4		5 1/4		6		4 1/4		5 1/4		
	Inner	Outer	Inner	Outer	Inner	Outer	Inner	Outer	Inner	Outer	Inner	Outer	Inner	Outer	Inner	Outer	Inner	Outer	Inner	Outer	Inner	Outer	Inner	Outer	Inner	Outer	
Class																											
A-25	0.26	0.18	0.22	0.15	0.19	0.13	0.30	0.30	0.28	0.19	0.24	0.16	0.21	0.14	0.32	0.32	0.30	0.20	0.25	0.17	0.23	0.15	0.34	0.34	0.34	0.34	0.34
B-25	0.43	0.25	0.33	0.19	0.28	0.15	0.43	0.33	0.45	0.27	0.36	0.21	0.32	0.18	0.45	0.36	0.49	0.29	0.38	0.22	0.34	0.19	0.49	0.49	0.49	0.49	0.49
C-25	0.62	0.33	0.46	0.24	0.37	0.19	0.62	0.46	0.66	0.36	0.50	0.27	0.44	0.22	0.66	0.50	0.72	0.40	0.53	0.28	0.47	0.24	0.72	0.72	0.72	0.72	0.72
D-25	0.80	0.42	0.58	0.29	0.47	0.22	0.80	0.58	0.86	0.45	0.65	0.32	0.54	0.26	0.86	0.65	0.97	0.50	0.69	0.35	0.58	0.28	0.69
A-50	0.35	0.26	0.30	0.23	0.27	0.21	0.59	0.59	0.38	0.28	0.32	0.25	0.30	0.23	0.63	0.63	0.41	0.30	0.35	0.26	0.32	0.25	0.67	0.67	0.67	0.67	0.67
B-50	0.51	0.33	0.42	0.27	0.36	0.23	0.59	0.59	0.55	0.36	0.45	0.30	0.40	0.26	0.63	0.63	0.58	0.39	0.48	0.31	0.43	0.28	0.67	0.67	0.67	0.67	0.67
C-50	0.70	0.42	0.54	0.32	0.46	0.27	0.70	0.59	0.75	0.45	0.59	0.36	0.52	0.30	0.75	0.63	0.81	0.49	0.63	0.38	0.55	0.33	0.81	0.81	0.81	0.81	0.81
D-50	0.88	0.50	0.67	0.38	0.55	0.30	0.88	0.67	0.97	0.54	0.73	0.41	0.62	0.34	0.97	0.73	1.06	0.59	0.77	0.44	0.68	0.37	0.77
A-75	0.44	0.36	0.39	0.31	0.35	0.28	0.47	0.38	0.42	0.34	0.39	0.31	0.50	0.41	0.44	0.36	0.42	0.33
B-75	0.61	0.43	0.50	0.36	0.44	0.31	0.65	0.46	0.54	0.39	0.49	0.35	0.69	0.49	0.57	0.41	0.52	0.37
C-75	0.78	0.51	0.63	0.41	0.54	0.34	0.84	0.54	0.68	0.44	0.60	0.39	0.90	0.58	0.72	0.47	0.65	0.42
D-75	0.99	0.59	0.75	0.46	0.62	0.37	1.06	0.64	0.81	0.50	0.72	0.43	1.14	0.70	0.86	0.53	0.76	0.46
A-100	0.53	0.45	0.52	0.43	0.48	0.40	0.57	0.48	0.55	0.45	0.51	0.42	0.62	0.51	0.59	0.48	0.54	0.45
B-100	0.70	0.52	0.58	0.44	0.52	0.39	0.75	0.55	0.64	0.48	0.57	0.44	0.79	0.59	0.67	0.50	0.61	0.46
C-100	0.87	0.59	0.71	0.49	0.61	0.42	0.95	0.65	0.77	0.53	0.69	0.47	1.02	0.70	0.81	0.56	0.73	0.50
D-100	1.08	0.69	0.83	0.54	0.70	0.45	1.15	0.73	0.90	0.58	0.79	0.51	1.24	0.79	0.97	0.63	0.84	0.54
A-125	0.65	0.53	0.64	0.54	0.63	0.54	0.69	0.56	0.68	0.57	0.67	0.57	0.74	0.60	0.73	0.60	0.72	0.61
B-125	0.79	0.62	0.67	0.54	0.66	0.51	0.84	0.66	0.73	0.57	0.70	0.55	0.89	0.70	0.76	0.61	0.74	0.58
C-125	0.98	0.70	0.80	0.57	0.69	0.50	1.05	0.74	0.86	0.63	0.77	0.56	1.12	0.79	0.91	0.66	0.82	0.59
D-125	1.16	0.77	0.91	0.63	0.78	0.53	1.24	0.83	1.00	0.68	0.87	0.59	1.33	0.89	1.06	0.72	0.94	0.64



TABLE 1 Continued

Internal Designated Dia, in.		Circumferential reinforcement, in. ² /linear ft of pipe ^B																									
		54						57 ^C						60													
Type of Reinforcement	Wall Thickness, in.	Circular						Circular						Elliptical													
		4½		5½		6¼		4¾		5¾		6½		4¾		5¾		6¾		5		6					
Layers of Reinforcement	in.	Inner	Outer	Inner	Outer	Inner	Outer	Inner	Outer	Inner	Outer	Inner	Outer	Inner	Outer	Inner	Outer	Inner	Outer	Inner	Outer	Inner	Outer				
		Class																									
A-25		0.31	0.21	0.27	0.18	0.25	0.16	0.33	0.22	0.28	0.19	0.26	0.17	0.38	0.38	0.35	0.23	0.20	0.30	0.41	0.31	0.38	0.29	0.18	0.39	0.39	
B-25		0.50	0.30	0.40	0.23	0.36	0.20	0.52	0.31	0.43	0.25	0.38	0.22	0.52	0.43	0.54	0.32	0.45	0.45	0.55	0.44	0.55	0.37	0.51	0.33	0.54	0.45
C-25		0.75	0.41	0.57	0.30	0.50	0.26	0.78	0.43	0.61	0.32	0.53	0.28	0.78	0.61	0.81	0.45	0.64	0.64	0.74	0.55	0.74	0.45	0.67	0.39	0.81	0.64
D-25		1.00	0.52	0.73	0.37	0.63	0.30	1.03	0.54	0.77	0.40	0.67	0.33	...	0.77	1.07	0.56	0.81	0.81	0.91	0.67	0.91	0.52	0.81	0.45	...	0.81
A-50		0.42	0.32	0.37	0.28	0.34	0.26	0.44	0.33	0.39	0.29	0.36	0.28	0.75	0.75	0.46	0.35	0.41	0.41	0.41	0.35	0.41	0.38	0.29	0.78	0.78	0.78
B-50		0.62	0.41	0.50	0.33	0.46	0.30	0.64	0.42	0.52	0.35	0.48	0.32	0.75	0.75	0.66	0.44	0.55	0.55	0.66	0.44	0.55	0.37	0.51	0.33	0.78	0.78
C-50		0.84	0.51	0.67	0.40	0.59	0.35	0.87	0.53	0.71	0.42	0.64	0.37	0.90	0.90	0.91	0.55	0.74	0.74	0.91	0.55	0.74	0.45	0.67	0.39	0.96	0.78
D-50		1.09	0.63	0.82	0.46	0.72	0.39	1.13	0.65	0.86	0.49	0.77	0.43	...	0.88	1.16	0.67	0.91	0.91	1.16	0.67	0.91	0.52	0.81	0.45	...	0.94
A-75		0.53	0.43	0.47	0.38	0.44	0.35	0.55	0.44	0.49	0.40	0.47	0.37	0.57	0.46	0.52	0.52	0.66	0.47	0.66	0.42	0.49	0.39
B-75		0.72	0.51	0.60	0.43	0.55	0.39	0.74	0.53	0.63	0.45	0.58	0.42	0.77	0.55	0.66	0.66	0.77	0.55	0.66	0.47	0.61	0.44
C-75		0.96	0.62	0.76	0.50	0.69	0.45	1.00	0.64	0.80	0.52	0.73	0.47	1.03	0.67	0.85	0.85	1.03	0.67	0.85	0.55	0.77	0.50
D-75		1.18	0.72	0.91	0.56	0.81	0.49	1.22	0.75	0.97	0.59	0.86	0.52	1.26	0.78	1.02	1.02	1.26	0.78	1.02	0.63	0.92	0.55
A-100		0.64	0.53	0.62	0.51	0.58	0.47	0.67	0.55	0.66	0.54	0.61	0.50	0.70	0.57	0.70	0.70	0.70	0.57	0.70	0.56	0.64	0.53
B-100		0.82	0.62	0.70	0.53	0.65	0.49	0.85	0.64	0.74	0.55	0.68	0.52	0.88	0.67	0.88	0.88	0.88	0.67	0.88	0.58	0.72	0.54
C-100		1.06	0.72	0.86	0.59	0.78	0.54	1.10	0.75	0.90	0.63	0.82	0.57	1.14	0.78	0.96	0.96	1.14	0.78	0.96	0.66	0.87	0.60
D-100		1.28	0.82	1.02	0.66	0.89	0.58	1.32	0.85	1.07	0.69	0.96	0.62	1.39	0.88	1.12	1.12	1.39	0.88	1.12	0.73	1.01	0.65
A-125		0.77	0.64	0.77	0.64	0.76	0.64	0.82	0.67	0.82	0.68	0.80	0.67	0.86	0.71	0.85	0.85	0.86	0.71	0.85	0.72	0.85	0.71
B-125		0.92	0.73	0.80	0.64	0.78	0.62	0.97	0.75	0.83	0.68	0.82	0.65	1.01	0.78	0.86	0.86	1.01	0.78	0.86	0.72	0.87	0.69
C-125		1.16	0.82	0.97	0.70	0.87	0.64	1.20	0.85	1.02	0.73	0.92	0.67	1.25	0.89	1.07	1.07	1.25	0.89	1.07	0.77	0.98	0.71
D-125		1.40	0.92	1.11	0.76	1.00	0.68	1.45	0.97	1.17	0.79	1.06	0.72	1.50	1.00	1.22	1.22	1.50	1.00	1.22	0.83	1.11	0.76



TABLE 1 Continued

Internal Designated Dia., in.		Circumferential reinforcement, in. ² /linear ft of pipe ^e																					
		63 ^c						66						69 ^c									
		Circular			Elliptical			Circular			Elliptical			Circular			Elliptical						
Wall Thickness, in.	5/4	6/4		7	5/4	6/4	5/2	6 1/2		7 1/4		5 1/2	6 1/2	5 3/4	6 3/4		7 1/2	5 3/4	6 3/4				
		Inner	Outer					Inner	Outer	Inner	Outer				Inner	Outer				Inner	Outer	Inner	Outer
Layers of Reinforcement	Inner	Outer	Inner	Outer	Inner	Outer	Inner	Outer	Inner	Outer	Inner	Outer	Inner	Outer	Inner	Outer	Inner	Outer	Inner	Outer			
Class																							
A-25	0.37	0.25	0.32	0.22	0.30	0.20	0.41	0.41	0.39	0.26	0.34	0.23	0.32	0.21	0.43	0.43	0.41	0.27	0.36	0.24	0.33	0.22	0.45
B-25	0.57	0.35	0.48	0.28	0.43	0.25	0.57	0.48	0.59	0.36	0.50	0.29	0.45	0.26	0.60	0.50	0.62	0.37	0.52	0.31	0.48	0.28	0.63
C-25	0.85	0.47	0.68	0.37	0.60	0.31	0.85	0.68	0.87	0.49	0.71	0.38	0.63	0.33	0.87	0.71	0.89	0.50	0.73	0.40	0.66	0.35	0.90
D-25	1.13	0.59	0.87	0.45	0.76	0.38	...	0.87	1.17	0.63	0.91	0.47	0.81	0.41	...	0.91	1.20	0.65	0.97	0.50	0.85	0.43	...
A-50	0.49	0.37	0.44	0.33	0.41	0.31	0.82	0.82	0.51	0.39	0.46	0.35	0.43	0.33	0.86	0.86	0.53	0.40	0.48	0.36	0.46	0.34	0.90
B-50	0.69	0.46	0.58	0.39	0.54	0.36	0.82	0.82	0.72	0.48	0.62	0.41	0.57	0.37	0.86	0.86	0.74	0.49	0.63	0.43	0.59	0.39	0.90
C-50	0.97	0.58	0.79	0.47	0.71	0.42	1.01	0.83	1.00	0.61	0.82	0.49	0.74	0.44	1.05	0.87	1.02	0.63	0.85	0.51	0.77	0.47	1.10
D-50	1.23	0.71	0.98	0.55	0.87	0.49	...	1.01	1.27	0.74	1.03	0.58	0.92	0.51	...	1.07	1.31	0.76	1.08	0.62	0.97	0.54	...
A-75	0.62	0.49	0.55	0.44	0.52	0.42	0.64	0.51	0.58	0.46	0.55	0.44	0.67	0.53	0.61	0.48	0.58	0.46	...
B-75	0.81	0.57	0.70	0.50	0.66	0.47	0.84	0.60	0.73	0.52	0.69	0.49	0.86	0.62	0.76	0.55	0.72	0.52	...
C-75	1.08	0.70	0.89	0.58	0.82	0.53	1.11	0.73	0.94	0.61	0.85	0.56	1.14	0.75	0.97	0.64	0.90	0.58	...
D-75	1.36	0.82	1.09	0.67	0.98	0.59	1.40	0.85	1.14	0.70	1.03	0.63	1.45	0.88	1.19	0.73	1.08	0.66	...
A-100	0.74	0.61	0.73	0.59	0.68	0.55	0.76	0.63	0.77	0.62	0.71	0.57	0.79	0.66	0.80	0.64	0.74	0.60	...
B-100	0.92	0.70	0.81	0.62	0.76	0.57	0.97	0.73	0.85	0.65	0.79	0.61	1.00	0.75	0.88	0.68	0.83	0.64	...
C-100	1.20	0.82	1.01	0.70	0.92	0.64	1.23	0.84	1.05	0.73	0.97	0.67	1.26	0.87	1.09	0.76	1.01	0.70	...
D-100	1.47	0.95	1.19	0.77	1.08	0.70	1.51	0.98	1.25	0.81	1.13	0.73	1.56	1.01	1.30	0.85	1.19	0.77	...
A-125	0.90	0.74	0.90	0.75	0.89	0.75	0.95	0.78	0.94	0.79	0.93	0.78	0.99	0.82	0.98	0.82	0.97	0.82	...
B-125	1.06	0.82	0.93	0.75	0.91	0.72	1.09	0.85	0.96	0.79	0.95	0.76	1.13	0.88	1.00	0.82	1.00	0.79	...
C-125	1.31	0.95	1.13	0.81	1.04	0.75	1.37	0.98	1.17	0.84	1.08	0.78	1.40	1.01	1.21	0.88	1.12	0.82	...
D-125	1.58	1.06	1.30	0.88	1.18	0.81	1.62	1.09	1.38	0.92	1.24	0.84	1.68	1.13	1.43	0.97	1.30	0.88	...



TABLE 1 Continued

Internal Designated Dia., in.	Circumferential reinforcement, in. ² /linear ft of pipe ^B																				
	72				78				84												
	Circular				Elliptical				Circular												
Type of Reinforcement	6		7		7 ³ / ₄		6		7		6 ¹ / ₂		7 ¹ / ₂		8 ¹ / ₄		8		8 ³ / ₄		
	Inner	Outer	Inner	Outer	Inner	Outer	Single	Single	Single	Single	Inner	Outer	Inner	Outer	Inner	Outer	Inner	Outer	Inner	Outer	
Layers of Reinforcement																					
Class																					
A-25	0.45	0.30	0.40	0.26	0.37	0.24	0.48	0.47	0.43	0.29	0.41	0.27	0.53	0.35	0.47	0.31	0.45	0.29	0.45	0.29	
B-25	0.68	0.41	0.57	0.34	0.52	0.30	0.68	0.57	0.62	0.37	0.57	0.33	0.77	0.46	0.67	0.40	0.62	0.36	0.62	0.36	
C-25	1.00	0.55	0.80	0.44	0.72	0.38	1.00	0.80	0.86	0.47	0.78	0.42	1.09	0.62	0.91	0.51	0.84	0.45	0.84	0.45	
D-25	1.37	0.72	1.07	0.55	0.95	0.47	...	1.07	1.15	0.61	1.04	0.52	1.51	0.81	1.23	0.65	1.11	0.57	1.11	0.57	
A-50	0.59	0.44	0.53	0.40	0.50	0.37	0.94	0.94	0.57	0.43	0.55	0.41	0.68	0.50	0.63	0.46	0.59	0.44	0.59	0.44	
B-50	0.81	0.54	0.70	0.47	0.65	0.43	0.94	0.94	0.76	0.50	0.71	0.47	0.92	0.62	0.82	0.54	0.77	0.51	0.77	0.51	
C-50	1.12	0.69	0.92	0.56	0.84	0.51	1.15	0.96	1.00	0.61	0.92	0.55	1.23	0.76	1.06	0.65	0.99	0.59	0.99	0.59	
D-50	1.48	0.84	1.18	0.68	1.07	0.59	...	1.20	1.28	0.74	1.16	0.66	1.64	0.96	1.38	0.79	1.26	0.71	1.26	0.71	
A-75	0.73	0.58	0.66	0.53	0.63	0.51	0.72	0.57	0.69	0.55	0.84	0.66	0.78	0.62	0.75	0.59	0.75	0.59	
B-75	0.96	0.68	0.83	0.60	0.78	0.56	0.90	0.65	0.85	0.61	1.08	0.77	0.97	0.70	0.92	0.66	0.92	0.66	
C-75	1.25	0.82	1.06	0.70	0.98	0.64	1.13	0.75	1.05	0.69	1.39	0.91	1.21	0.80	1.13	0.74	1.13	0.74	
D-75	1.60	0.98	1.31	0.80	1.19	0.72	1.43	0.87	1.31	0.79	1.78	1.10	1.52	0.94	1.40	0.85	1.40	0.85	
A-100	0.87	0.72	0.83	0.68	0.77	0.63	0.90	0.73	0.83	0.68	1.00	0.82	0.97	0.79	0.90	0.73	0.90	0.73	
B-100	1.10	0.82	0.97	0.73	0.90	0.69	1.05	0.79	0.98	0.74	1.23	0.92	1.12	0.84	1.06	0.80	1.06	0.80	
C-100	1.40	0.96	1.19	0.82	1.09	0.76	1.27	0.89	1.17	0.82	1.54	1.07	1.36	0.95	1.26	0.88	1.26	0.88	
D-100	1.73	1.11	1.45	0.94	1.30	0.84	1.56	1.01	1.42	0.91	1.94	1.24	1.65	1.08	1.52	0.99	1.52	0.99	
A-125	1.04	0.85	1.03	0.85	1.02	0.85	1.12	0.92	1.11	0.91	1.20	0.99	1.21	0.99	1.19	0.96	1.19	0.96	
B-125	1.23	0.97	1.11	0.87	1.04	0.82	1.19	0.94	1.13	0.89	1.40	1.09	1.27	1.00	1.21	0.98	1.21	0.98	
C-125	1.53	1.10	1.32	0.97	1.22	0.89	1.42	1.03	1.31	0.96	1.68	1.22	1.51	1.10	1.42	1.03	1.42	1.03	
D-125	1.89	1.24	1.57	1.07	1.43	0.97	1.69	1.15	1.55	1.05	2.08	1.40	1.79	1.22	1.66	1.13	1.66	1.13	



TABLE 1 Continued

		Circumferential reinforcement, in. ² /linear ft of pipe ^A																	
Internal Designated Dia., in.	Type of Reinforcement	90				96				102				108					
		7½		8		8		8½		8½		9		9		9½			
Wall Thickness, in.	Layers of Reinforcement	Outer		Inner		Outer		Inner		Outer		Inner		Outer		Inner		Outer	
		Class		Inner	Outer	Inner	Outer	Inner	Outer	Inner	Outer	Inner	Outer	Inner	Outer	Inner	Outer	Inner	Outer
A-25		0.57	0.38	0.54	0.36	0.62	0.41	0.58	0.39	0.66	0.44	0.63	0.42	0.71	0.47	0.68	0.45		
B-25		0.82	0.49	0.77	0.46	0.87	0.53	0.82	0.49	0.92	0.56	0.87	0.52	0.99	0.59	0.94	0.56		
C-25		1.14	0.65	1.06	0.59	1.20	0.68	1.12	0.63	1.26	0.72	1.18	0.67	1.32	0.76	1.24	0.71		
D-25		1.57	0.84	1.43	0.76	1.62	0.88	1.49	0.80	1.69	0.92	1.56	0.84	1.75	0.97	1.64	0.89		
A-50		0.73	0.54	0.70	0.52	0.78	0.57	0.75	0.55	0.84	0.62	0.81	0.59	0.89	0.65	0.86	0.63		
B-50		0.98	0.66	0.92	0.62	1.04	0.70	0.99	0.66	1.10	0.74	1.05	0.70	1.16	0.78	1.11	0.74		
C-50		1.29	0.80	1.20	0.74	1.37	0.84	1.27	0.79	1.44	0.89	1.35	0.83	1.50	0.94	1.43	0.88		
D-50		1.70	1.00	1.57	0.90	1.77	1.04	1.64	0.96	1.86	1.09	1.72	1.01	1.93	1.14	1.80	1.06		
A-75		0.89	0.71	0.86	0.68	0.96	0.75	0.92	0.73	1.02	0.80	0.99	0.77	1.08	0.84	1.05	0.82		
B-75		1.14	0.81	1.08	0.78	1.21	0.86	1.15	0.82	1.27	0.91	1.22	0.87	1.36	0.97	1.29	0.92		
C-75		1.46	0.96	1.37	0.90	1.53	1.01	1.44	0.96	1.60	1.07	1.52	1.01	1.68	1.12	1.60	1.07		
D-75		1.87	1.15	1.71	1.06	1.94	1.20	1.79	1.12	2.02	1.25	1.89	1.17	2.10	1.31	1.98	1.23		
A-100		1.07	0.87	1.04	0.84	1.13	0.92	1.11	0.90	1.20	0.98	1.17	0.96	1.27	1.04	1.24	1.01		
B-100		1.30	0.99	1.24	0.94	1.39	1.04	1.32	1.00	1.46	1.10	1.41	1.06	1.54	1.15	1.49	1.12		
C-100		1.61	1.12	1.52	1.06	1.69	1.18	1.60	1.12	1.77	1.24	1.69	1.18	1.87	1.30	1.78	1.25		
D-100		2.01	1.30	1.88	1.21	2.09	1.37	1.96	1.28	2.18	1.43	2.05	1.35	2.27	1.49	2.15	1.42		
A-125		1.29	1.06	1.29	1.06	1.38	1.13	1.38	1.13	1.47	1.19	1.47	1.19	1.56	1.26	1.55	1.26		
B-125		1.48	1.15	1.42	1.11	1.56	1.21	1.50	1.17	1.64	1.28	1.58	1.24	1.73	1.35	1.67	1.30		
C-125		1.77	1.28	1.68	1.22	1.87	1.36	1.77	1.29	1.96	1.43	1.88	1.37	2.05	1.49	1.97	1.44		
D-125		2.16	1.47	2.02	1.38	2.25	1.53	2.12	1.45	2.34	1.60	2.22	1.52	2.46	1.67	2.32	1.60		

^A Steel areas may be interpolated between those shown for variations in wall thickness. See 7.2 for provisions for special designs.

^B The prescribed amounts of reinforcement do not provide any allowance for pressure surges (water hammer) in pipelines.

^C Available in some areas.

APPENDIXES

(Nonmandatory Information)

X1. FIELD INSTALLATION PROCEDURES

X1.1 The class of pipe given in Table 1 for combined external load and hydrostatic head is based on a field installation procedure at least comparable to that described below. Where the designer does not expect to attain such an installation, a detailed design analysis of the pipe should be made taking into consideration the anticipated external loading, hydrostatic head, and installation procedure. Failure to comply with the requirements herein may result in a bedding angle of less than 90° as defined in Appendix X2 and may result in excessive pipe cracking.

X1.2 The trench shall be excavated of sufficient width to achieve the specified haunch backfill compaction, and to a depth of either 4 or 6 in. below the bottom of the pipe, to provide for granular cushion material as shown in Fig. X1.1. The trench shall be backfilled to the bottom of the pipe with uncompacted granular cushion material meeting the physical requirements of X1.2.2. After the pipe is placed in the trench to the correct grade and alignment, additional haunch support backfill material shall be compacted in accordance with X1.2.1 or X1.2.2, depending on the type of soil used as pipe material

backfill. An additional depth of 6 in. or more shall be removed if the native material in the trench is soft, low density, or unsuitable for a pipeline foundation. The additional 6 in. or more shall be compacted to the requirements of the design engineer.

X1.2.1 *Cohesive Soil or Granular Soil Containing More Than 5 % Fines*—If the haunch support backfill material is a cohesive soil or is a granular soil containing more than 5 % material passing the number 200 sieve, the material shall be placed in layers not exceeding 6 in. in thickness and compacted by appropriate surface methods such as tamping, rolling, vibration, or a combination thereof. The material shall be placed from the bottom of the pipe to a height of 0.37 times the outside diameter of the pipe, shall be placed and compacted in such a manner as to completely fill the space under the haunches of the pipe, and shall be compacted throughout to a minimum of 95 % of laboratory maximum density as determined in accordance with Test Method D 698.

X1.2.2 *Granular Soil Containing 5 % Fines or Less*—If the haunch support backfill material is a cohesionless, free-draining soil (containing no more than 5 % material passing the number 200 sieve) it shall be placed a minimum depth of 0.37 times the outside diameter of the pipe and shall be compacted by saturation and internal vibrations in such a manner as to completely fill the spaces under the haunches of the pipe and shall be compacted throughout to a minimum of 70 % relative density as determined in accordance with Test Methods D 4253 and D 4254.

NOTE X1.1—In order to achieve specified density, it may be necessary to provide means for draining the water utilized during vibration whenever the trench sides and subgrade are incapable of readily absorbing the excess.

X1.2.3 The pipe backfill material in X1.2.1 and X1.2.2 shall have a maximum particle size not exceeding 3/4 in. and shall be graded to preclude migration of soil particles. The backfill material placed above the 0.37 outside diameter level shall be compacted or uncompacted to the requirements of the design engineer.

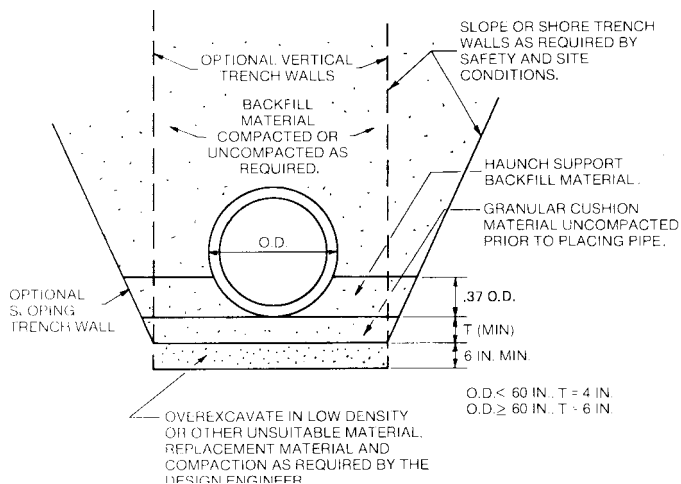

FIG. X1.1 Pipe Bedding

X2. DESIGN CRITERIA FOR TABLE 1

X2.1 The designs for reinforced concrete low-head pressure pipe presented in Table 1 are based on specific loadings, bedding, and design requirements summarized in this appendix as information for the designer in considering the suitability of the designs.

X2.2 *Loads*—This pipe is designed for dead load of the pipe itself, the earth load, the water load, and the internal pressure due to hydrostatic head calculated from the inside top

of the pipe to the design gradient. The hydrostatic head defined in Table 1 is measured to the horizontal centerline of the pipe.

X2.2.1 The earth load is based on a one-foot length of the prism of earth directly over the outside diameter of the pipe. The *effective* unit weight of earth, in pounds per cubic foot is:

$$w_e = 100 + 20(H_e/OD) \quad (X2.1)$$

where:



H_e = earth cover over top of pipe, ft,
 OD = outside diameter of pipe, ft, and
 Maximum w_e = 150 lb/ft³.

The earth load on the pipe is

$$W = w_e H_e (OD), \text{ lb/linear ft} \quad (\text{X2.2})$$

NOTE X2.1—The earth load from X2.2.1 represents loose backfill over pipe in a trench of any width, as may be used for cross-country pipelines. For any other earth load design assumption selected by the engineer, the new earth load may be compared to the design earth load in pounds per linear foot from X2.2.1 for the range of cover loads, A through D , within the same pressure head designation.

X2.2.2 The prescribed amounts of reinforcement do not provide any allowance for pressure surges (water hammer) in pipelines.

X2.3 *Bedding*—The bedding described in Appendix X1 is assumed to result in bearing over a 90° central angle. Pressure distributions and the analysis of stresses in the pipe wall are based on theory.¹³

X2.4 *Design Requirements*—Reinforced concrete design for combined internal and external loads is based on ACI Code 318, with a concrete compressive strength of 4500 psi, reinforcing steel with a yield point strength of 40 000 psi, a load factor of 1.8, and a capacity reduction factor of 1.0.

X2.4.1 The minimum steel area is calculated for hydrostatic head only. The minimum area of circular reinforcement is:

$$A_s = \frac{6(0.433H_w)D}{f_s}, \text{ in.}^2/\text{linear ft} \quad (\text{X2.3})$$

where:

H_w = hydrostatic head, ft,
 D = internal designated diameter, in., and
 f_s = 17 000 – 35 H_w , allowable tensile stress in the reinforcement, psi centerline.

For elliptical reinforcement, the minimum area of reinforcement is 1.6 times that required for circular reinforcement for hydrostatic head alone.

X2.4.2 The design concrete cover is the average of the dimensions given in 7.4 of the specification for a particular range of pipe diameters. For single-layer reinforcement, the steel is assumed to be at the center line of the cross section.

X2.4.3 The minimum wall thickness (t_w) of the pipe is:

$$t_w \text{ min} = \frac{D}{12}, \text{ in.} \quad (\text{X2.4})$$

where:

D = internal designated diameter, in.

The tensile stress (f_{ct}) in the concrete of the pipe wall is:

$$f_{ct} = \frac{0.433H_w D}{2t_w}, \text{ psi} \quad (\text{X2.5})$$

where:

t_w = design pipe wall thickness, assumed unreinforced, in., and

f_{ct} = ≤325 psi for the concrete design strength of 4500 psi shown in Table 1.

¹³ Olander, H.C., *Stress Analysis of Concrete Pipe*, Engineering Monograph No. 6, U.S. Bureau of Reclamation, October 1950.

ASTM International takes no position respecting the validity of any patent rights asserted in connection with any item mentioned in this standard. Users of this standard are expressly advised that determination of the validity of any such patent rights, and the risk of infringement of such rights, are entirely their own responsibility.

This standard is subject to revision at any time by the responsible technical committee and must be reviewed every five years and if not revised, either reapproved or withdrawn. Your comments are invited either for revision of this standard or for additional standards and should be addressed to ASTM International Headquarters. Your comments will receive careful consideration at a meeting of the responsible technical committee, which you may attend. If you feel that your comments have not received a fair hearing you should make your views known to the ASTM Committee on Standards, at the address shown below.

This standard is copyrighted by ASTM International, 100 Barr Harbor Drive, PO Box C700, West Conshohocken, PA 19428-2959, United States. Individual reprints (single or multiple copies) of this standard may be obtained by contacting ASTM at the above address or at 610-832-9585 (phone), 610-832-9555 (fax), or service@astm.org (e-mail); or through the ASTM website (www.astm.org).