



## Standard Specification for Clay Drain Tile and Perforated Clay Drain Tile<sup>1</sup>

This standard is issued under the fixed designation C 4; the number immediately following the designation indicates the year of original adoption or, in the case of revision, the year of last revision. A number in parentheses indicates the year of last reapproval. A superscript epsilon ( $\epsilon$ ) indicates an editorial change since the last revision or reapproval.

*This standard has been approved for use by agencies of the Department of Defense.*

### 1. Scope

1.1 This specification establishes the criteria for acceptance, prior to installation, of drain tile and perforated drain tile to be used for underdrainage, filter fields, leaching fields, and similar subdrainage installations.

1.2 The values stated in inch-pound units are to be regarded as the standard. The values given in parentheses are for information only.

1.3 The following safety hazards caveat pertains only to the Test Methods portion of this specification: *This standard does not purport to address all of the safety concerns, if any, associated with its use. It is the responsibility of the user of this standard to establish appropriate safety and health practices and determine the applicability of regulatory limitations prior to use.*

NOTE 1—Attention is called to Test Methods C 301 and Terminology C 896.

### 2. Referenced Documents

#### 2.1 ASTM Standards:

C 301 Test Methods for Vitrified Clay Pipe<sup>2</sup>

C 896 Terminology Relating to Clay Products<sup>2</sup>

### 3. Terminology

#### 3.1 Definitions:

3.1.1 *Clay, fire clay, shale, and surface clay* are as defined in Terminology C 896.

3.1.2 Within this specification, the terms *tile, drain tile, and clay drain tile* are synonyms.

### 4. Classification

4.1 Four classes of clay drain tile are specified:

4.1.1 Standard.

4.1.2 Extra Quality.

4.1.3 Heavy Duty.

4.1.4 Extra Strength.

4.2 Drain tile of a higher strength classification than that

specified by the purchaser may be furnished by the seller, provided the substituted drain tile meets the physical requirements of the class specified.

### 5. Materials and Manufacture

5.1 Drain tile shall be manufactured from clay, fire clay, shale, surface clay, or a combination of these materials, that, when formed into tile and fired to suitable temperatures, yields a product that conforms to this specification.

### 6. Physical Properties

6.1 Drain tile shall meet the physical test requirements for the class, as specified in Table 1.

6.2 The maximum water absorption (5-h boiling) shall be as follows:

	Average, %	Individual, %
Standard	13	16
Extra Quality	11	13
Heavy Duty	11	13
Extra Strength	11	13

6.3 The requirements for water absorption (5-h boiling) shall be waived, provided that test specimens meet the requirements of the freezing and thawing test, Section 13, of this specification

### 7. Sizes and Perforations

7.1 The size of drain tile shall be designated by inside diameter. Not all sizes and strengths may be available from all manufacturers.

7.2 The minimum length of drain tile smaller than 12 in. (305 mm) shall be approximately 12 in.

7.3 The length of drain tile 12 through 30-in. (305 through 760-mm) diameter shall be not less than their diameter.

7.4 *Perforations*—Perforations shall be circular and cleanly cut through the tile wall. They shall be arranged in rows parallel to the longitudinal axis of the tile. The minimum number of rows of perforations shall be as shown in Table 2.

7.4.1 Where two rows of perforations are used, the rows shall be separated by an arc of  $90 \pm 15^\circ$ .

7.4.2 Where four rows of perforations are used, the rows shall be symmetrical around a vertical centerline. The lowermost rows of perforations shall be separated by an arc of  $90 \pm 10^\circ$ , and the uppermost rows shall be separated by an arc of not over  $160^\circ$  measured around the lower part of the tile (Fig. 1).

<sup>1</sup> This specification is under the jurisdiction of ASTM Committee C-4 on Vitrified Clay Pipe and is the direct responsibility of Subcommittee C04.20 on Methods of Test and Specifications.

Current edition approved Jan. 10, 2000. Published March 2000. Originally published as C 4 – 14. Last previous edition C 4 – 99.

<sup>2</sup> *Annual Book of ASTM Standards*, Vol 04.05.

**TABLE 1 Physical Test Requirements for Clay Drain Tile**

Internal Diameter of Tile, in.	Standard		Extra Quality		Heavy Duty		Extra Strength	
	Minimum Crushing Strength, <sup>A</sup> lbf/linear ft (kN/m)		Minimum Crushing Strength, <sup>A</sup> lbf/linear ft (kN/m)		Minimum Crushing Strength, <sup>A</sup> lbf/linear ft (kN/m)		Minimum Crushing Strength, <sup>A</sup> lbf/linear ft (kN/m)	
	Average	Individual	Average	Individual	Average	Individual	Average	Individual
4	800 (11.7)	680 (9.9)	1100 (16.0)	990 (14.5)	1400 (20.4)	1260 (18.4)	2000 (29.2)	1800 (26.3)
5	800 (11.7)	680 (9.9)	1100 (16.0)	990 (14.5)	1400 (20.4)	1260 (18.4)	2000 (29.2)	1800 (26.3)
6	800 (11.7)	680 (9.9)	1100 (16.0)	990 (14.5)	1400 (20.4)	1260 (18.4)	2000 (29.2)	1800 (26.3)
8	800 (11.7)	680 (9.9)	1100 (16.0)	990 (14.5)	1500 (21.9)	1350 (19.7)	2140 (31.2)	1920 (28.0)
10	800 (11.7)	680 (9.9)	1100 (16.0)	990 (14.5)	1550 (22.6)	1400 (20.4)	2200 (32.1)	1980 (28.9)
12	800 (11.7)	680 (9.9)	1100 (16.0)	990 (14.5)	1700 (24.8)	1530 (22.3)	2420 (35.3)	2170 (31.7)
14	840 (12.3)	720 (10.5)	1100 (16.0)	990 (14.5)	1850 (27.0)	1660 (24.2)	2640 (38.5)	2370 (34.6)
15	870 (12.7)	740 (10.8)	1150 (16.8)	1030 (15.0)	1980 (28.9)	1780 (26.0)	2800 (40.9)	2620 (38.3)
16	...	...	1200 (17.5)	1080 (15.8)	2100 (30.7)	1890 (27.6)	3000 (43.8)	2700 (39.4)
18	...	...	1300 (19.0)	1170 (17.1)	2340 (34.2)	2100 (30.7)	3300 (48.2)	2970 (43.4)
21	...	...	1450 (21.2)	1300 (19.0)	2680 (39.1)	2410 (35.2)	...	...
24	...	...	1600 (23.4)	1440 (21.0)	3000 (43.8)	2700 (39.4)	...	...
27	...	...	1800 (26.3)	1620 (23.7)	3330 (48.6)	3000 (43.8)	...	...
30	...	...	2000 (29.2)	1800 (26.3)	3590 (52.4)	3230 (47.2)	...	...

<sup>A</sup> Strengths of sizes not listed may be interpolated between tabular values of sizes and strengths of the nearest listed diameters.

**TABLE 2 Number of Perforations per Row for Perforated Clay Drain Tile**

Tile Size Diameter, in. (mm)	Minimum Number of Rows of Perforations	Nominal Lengths of Tile, ft (m)				
		1 (0.30)	1½ (0.46)	2 (0.60)	2½ (0.76)	3 (0.91)
		Minimum Number of Perforations per Row				
4, 5, 6 (100, 125, 150)	4	3	5	7	9	11
4, 5, 6 (100, 125, 150)	2	5	8	11	13	15
8, 10, 12 (205, 255, 305)	4	3	5	7	9	11
14 to 18 (355 to 455)	6	...	5	7	9	11

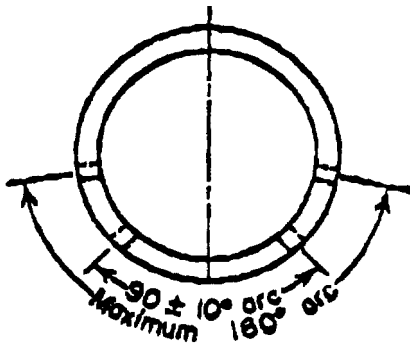

**FIG. 1 Spacing of Four Rows of Perforations**

7.4.3 If more than four rows of perforations are used, the spacing of rows shall be uniform between the limits in 7.4.2.

7.4.4 The purchaser shall specify the desired perforation diameter option of: (1) ¼ ± 1/16 in. (6.4 ± 1.6 mm) or (2) ½ ± 1/8 in. (12.7 ± 3.2 mm), and the number of rows of perforations.

7.4.5 Perforations shall not be spaced more than approximately 3 in. (75 mm) center-to-center along the rows.

**8. Workmanship and Finish**

8.1 Drain tile shall be free of cracks, checks, or chips that decrease the strength.

8.2 Drain tile shall conform to the permissible dimensional variations in Table 3.

8.3 Butt-end tile shall be furnished unless otherwise specified by the purchaser.

8.3.1 The ends of butt-end tile shall be sufficiently square as to make close joints.

**9. Sampling and Testing**

9.1 Tile shall be sampled and tested in accordance with Sections 11 through 13.

9.2 For test purposes, full-size drain tile shall be selected by the purchaser or his authorized representative. Tile shall be representative of the lot from which they are selected. The

**TABLE 3 Permissible Variations in Dimensions**

Physical Properties Specified	Standard	Extra Quality, Heavy Duty, and Extra Strength
Permissible variation of average diameter below specified diameter, %	3	3
Permissible variation between maximum and minimum diameters of same tile, percentage of wall thickness	75	65
Permissible variation of average length of tile sampled below manufacturer's specified length, %	3	3
Permissible variation from straightness, percentage of length	3	3
Permissible thickness of exterior blisters, lumps, and flakes, percentage of wall thickness	20	15
Permissible diameters of blisters, lumps, and flakes, percent of inside diameter	15	10

place or places of selection shall be designated when the purchase order is issued. The manufacturer or seller shall furnish test tile without charge.

9.3 Each tile shall be individually marked so that it is identifiable within the testing period.

**10. Basis of Acceptance**

10.1 Acceptability of nonperforated drain tile is determined by compliance with the requirements of Table 1, Table 3, and the inspection requirements of Section 14.

10.2 Acceptability of perforated drain tile is determined by compliance with the requirements of Tables 1-3 and the inspection requirements of Section 14.

**TEST METHODS**

**11. Crushing Strength Test**

*11.1 Test Samples:*

11.1.1 Test tile shall be sound, full size, and selected by the purchaser or his representative.

11.1.2 The number of tile to be tested shall not exceed 0.5 % of the number of tile of each size furnished, except that no less than five tile of each size shall be tested.

*11.2 Loading Apparatus (see Fig. 2):*

*11.2.1 Testing Machine:*

11.2.1.1 The loading apparatus may consist of any mechanically driven or hand-powered device that is capable of applying the necessary loads, with upper and lower bearings capable of transmitting these loads to the tile. The bearings shall be bearing beams and contact edges.

11.2.1.2 Any device that is capable of applying a load at a uniform rate, from 500 to 2000 lbf/linear ft-min (7300 to 29 200 N/linear m-min) of tile length, may be used for making the test.

11.2.1.3 The testing machine shall be sufficiently rigid so that the load distribution will not be appreciably affected by the deformation or yielding of any part. The machine and bearings shall be constructed to transmit the load in a vertical plane through the longitudinal axes of the bearings and tile. The bearings shall be attached to the machine so as to receive and

uniformly transmit the loads required in the tests, without vibration or shock.

11.2.1.4 The loading apparatus shall provide means for determination of load with an accuracy of at least 98 % and capable of retaining the loading information that results in the crushing strength determination.

11.2.2 *Bearing Beams*— Bearing beams shall be no less than the length of the barrel of the tile. Built-up bearing beams may be used, provided their deflection does not exceed that specified. In order for the bell or socket of the tile, if applicable, to clear the bearing beams, it is recommended that the bearing beams be faced with a metal or hardwood member for affixing the contact edges.

*11.2.3 Three-Edge Bearings:*

11.2.3.1 Three-edge bearings shall consist of an upper member, comprised of a bearing beam on which one contact edge is located so that it lies in the vertical plane passing through the longitudinal axis of the tile, and a lower member comprised of a bearing beam on which two contact edges are symmetrically located parallel to that vertical plane.

11.2.3.2 The contact edges shall consist of rubber strips alone or hardwood strips with plaster of paris fillets. Contact edges shall uniformly contact the outside of the tile.

11.2.3.3 The two contact edges on the lower member shall be spaced apart approximately 1 in./ft (25 mm/m) of tile diameter, but in no case less than 1 in. (25 mm).

11.2.3.4 Positioning strips may be used to align the upper contact edge and to align and space the lower contact edges. In the case of rubber contact edges, positioning strips shall not exceed one half of the thickness of the contact edge and may remain in place.

11.2.3.5 If rubber strips are used as contact edges, they shall be cut or formed from a material having a Shore A, instantaneous, durometer hardness between 45 and 60. The strips shall be of rectangular cross section, having a 2-in. (50-mm) width, and a thickness not less than 1 in. (25 mm) nor more than 1½ in. (38 mm). The contact edges shall be used with the 2-in. dimension in contact with the bearing beam. Rubber contact edges may be attached to the bearing beam by an adhesive, provided the contact edge remains firmly fixed in position.

11.2.3.6 If hardwood strips with plaster of paris fillets are used as contact edges, the strips shall be straight and have a cross section not less than 1 in. (25 mm) in either direction. The bottom contact edges shall have vertical sides, with the interior top corners having a radius of approximately ½ in. (13 mm). The contact edges shall be securely fastened to the beams.

11.2.3.7 Plaster of paris fillets shall be cast on hardwood contact edges to provide uniform bearing contact on the outside of the tile. Fillets shall be cast on the two lower contact edges and on the upper contact edge, along the tile crown. Sufficient excess plaster shall be removed from between the two lower contact edges to eliminate the possibility of a single continuous lower contact. The tile and contact edges shall be joined while the plaster of paris is still workable. Testing shall be performed only after the fillets have set.

*11.3 Procedure:*

11.3.1 Immerse tile, 12-in. (305-mm) diameter and smaller, in water for at least 1 h and not more than 2 h immediately

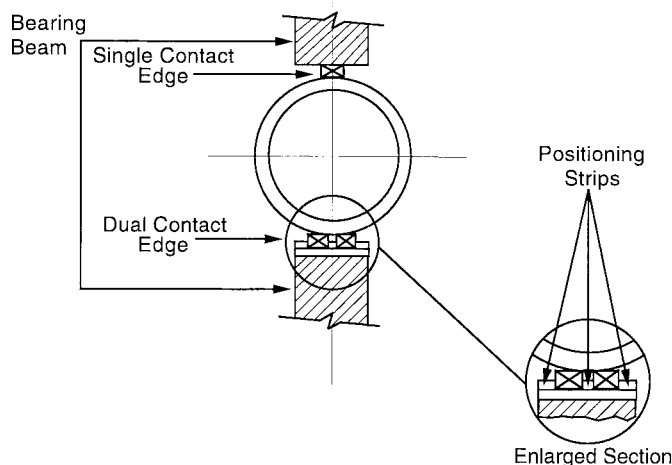

**FIG. 2 Loading Apparatus**

prior to testing. Tile with diameters larger than 12 in. (305 mm) may be tested without wetting, but shall not be dried except as may occur in complying with the provisions of 11.3.2.

11.3.2 No tile specimen shall be exposed to temperatures lower than 40°F (4.4°C) from the start of wetting until tested. Frozen tile shall be completely thawed before testing.

11.3.3 Strength tests are to be made by the three edge bearing method.

11.3.4 Center all bearings and test tile accurately for symmetrical distribution of load.

11.3.5 Apply load as continuously as testing equipment permits until the tile fails.

11.3.6 Record the load at which failure occurs.

11.4 *Calculation and Report*—Calculate and report the results of individual strength tests and the average in pounds-force per linear foot (or newtons per linear metre) of tile.

## 12. Absorption Test

### 12.1 *Test Specimens:*

12.1.1 All absorption test tile specimens shall be sound, solid pieces of tile. They shall be free of observable cracks or shattered edges and shall not have laminations and fissures more than is typical of the tile from which they are taken.

12.1.2 Test specimens shall consist of segments taken from each of the tile broken in the crushing strength test, and they shall be selected in accordance with the following provisions:

12.1.3 For tile with nominal inside diameters of 12 in. (305 mm) or less, and nominal lengths of 12 in., a “standard sample” shall consist of one full-length quarter segment taken from each of the tile broken in the strength test. A quarter segment is meant to be one of the four pieces into which a tile usually breaks in the strength test. Each segment selected shall be approximately of uniform width. If a tile breaks in such a manner that a satisfactory quarter segment cannot be obtained, the absorption test may be performed on two or more pieces whose combined areas approximate the area of a quarter tile of that size. Such a specimen shall be selected so that both ends and center portion of the tile are represented. The average absorption of the pieces so selected shall be considered to be the absorption for that tile.

12.1.4 For tile with nominal inside diameters or lengths in excess of 12 in. (305 mm), the absorption test shall be performed on three pieces, one piece taken from each end of the tile, and the third piece taken from near the center. These pieces preferably should come from tile broken in the strength test, and shall be of the full thickness of the barrel with all edges broken or cut. Each piece shall have an area not less than 25 in.<sup>2</sup> (160 cm<sup>2</sup>) as measured on one barrel surface. Average absorption of the three pieces shall be considered to be the absorption for that tile.

### 12.2 *Apparatus:*

12.2.1 A ventilated oven capable of holding a 500°F (260°C) temperature is required and shall be used for all drying.

12.2.2 A balance sensitive to 0.5 g when loaded with 1 kg is required and shall be used for all weighings. When weights other than metric are used, the same order of accuracy shall be attained.

### 12.3 *Procedure:*

12.3.1 *Drying*—Dry specimens at least 16 h in a ventilated oven at a temperature between 230 and 248°F (110 and 120°C) and until two successive weighings, at intervals of not less than 3 h, show an incremental loss not greater than 0.1 % of the original weight of the specimen.

12.3.1.1 Dry weight of the specimen shall be its weight after final drying and as soon as it has cooled to 75 ± 10°F (24 ± 5.5°C).

12.3.2 *Saturation*—Place dried specimens in a suitable container, pack tightly enough to prevent jostling, and cover with clean water. Heat water to boiling in not less than 1 or more than 2 h. Boil continuously for 5 h, and allow to cool to room temperature by natural loss of heat for not less than 12 h. Remove specimens from the water and allow to drain for not more than 1 min. Remove the superficial water by absorbant cloth or paper, and immediately weigh the specimens.

### 12.4 *Calculation and Report:*

12.4.1 Determine the weight of water absorbed, by the difference of weight of the saturated specimen and the dry specimen. Calculate the percent absorption by dividing the weight of absorbed water by the weight of the dried specimen (see 12.3.1), and report as percent of the initial dry weight.

12.4.2 Report results separately for each specimen, and the average for all specimens comprising the standard sample.

## 13. Freezing and Thawing Test

13.1 This section consists of two test procedures, Drying and Saturation (13.4.1), and Freezing and Thawing (13.4.2).

13.1.1 The Drying and Saturation procedure establishes that the tile from which test specimens are taken have a water absorption that exceeds the allowable value. Passing the Freezing and Thawing test attests to the fact that the quality of the tile under question warrants the waiver of the Water Absorption Test requirement.

### 13.2 *Test Specimens:*

13.2.1 Specimens for the Drying and Saturation and the Freezing and Thawing tests shall be from tile samples taken from the lot of tile from which water absorption tests have exceeded the allowable.

13.2.2 A sample consisting of five drain tile meeting all the requirements of this specification, with the exception of water absorption, shall be taken for the Drying and Saturation and the Freezing and Thawing tests.

13.2.3 These sample tile shall be selected by one of the following methods:

13.2.3.1 Preferably, samples should be from the tile originally used in the crushing strength tests, with any necessary additional tile selected as in 13.2.3.2.

13.2.3.2 The purchaser, with the manufacturer’s assistance, may select a sample of five tile from the lot that did not meet the absorption test requirement and for which it is desired to establish a waiver of that requirement.

13.2.3.3 No test specimen taken from the sample tile shall have been previously subjected to boiling.

13.2.4 The water absorption of each specimen tested in this resample shall be not less than the average absorption at which the tile previously failed to meet the absorption requirements.

13.2.5 Two sets of specimens shall be prepared from each of the tile selected.



13.2.5.1 One set of specimens shall be used for determining a new water absorption value for the lot, using the Drying and Saturation test. The additional set of specimens shall be used in the Freezing and Thawing test. The size and number of test specimens for each of these test procedures shall be as required in the Water Absorption section of this specification.

### 13.3 Apparatus:

13.3.1 Scales and weights of the same precision and accuracy as required for weighing in the absorption test (12.2.2) are required for the weighings in the Drying and Saturation test and in the Freezing and Thawing test.

13.3.2 A freezing apparatus is required. It shall meet the following requirements:

13.3.2.1 The freezing apparatus shall have sufficient heat absorption capacity for lowering the temperature of its freezing compartment to 14°F (−10°C), within 30 min after introduction of the specimens and for maintaining a temperature of 4 ± 10°F (−15.5 ± 5.5°C) during the test period.

13.3.2.2 The freezing chamber of the freezing apparatus shall provide an atmosphere in which air currents are no greater than necessary to maintain approximately uniform temperatures in all parts of the freezing compartment.

13.3.3 A water bath is required. It shall meet the following requirements:

13.3.3.1 The water bath shall be of sufficient volume to maintain the water temperature at 70 ± 15°F (21 ± 8.5°C) while the specimens are thawing. Running water may be used to assist in meeting this condition, or the water bath may be heated moderately.

### 13.4 Procedure:

#### 13.4.1 Drying and Saturation:

13.4.1.1 Dry and weigh specimens in accordance with the preparation for the water absorption test.

13.4.1.2 Saturate the specimens by submersion in water at a temperature within the range from 70 ± 30°F (21 ± 17°C) for not less than 24 h.

13.4.1.3 Remove the specimens from the water and allow to drain for not more than 1 min. Remove superficial water by use of absorbent cloth or paper, and immediately weigh the specimens. Return the specimens to water and keep them immersed until the freezing and thawing test is begun.

#### 13.4.2 Freezing and Thawing:

13.4.2.1 *Freezing*—Place the specimens, concave side up, in watertight trays. Adjust the depth of water in each tray to ½ in. (13 mm) and place the trays in the freezing compartment. Each freezing period in the freezing cycle shall be not less than 3 h for specimens taken from tile with barrel thickness up to 1.5 in. (38 mm), and 4 h for specimens taken from tile with barrel thickness exceeding 1.5 in. (38 mm).

13.4.2.2 *Thawing*—At the end of each freezing period, remove the trays containing the specimens and submerge the frozen tray contents in the water bath at a temperature of 75 ± 10°F (24 ± 5.5°C). The specimens are to remain in the bath until all of the ice has melted, but not less than 1 h. Following this, return the specimens to their trays with the appropriate amount of water, and return the trays to the freezer compartment for the next cycle.

13.4.2.3 Continue the freezing and thawing cycles until the

required number of cycles is completed.

13.4.2.4 The number of cycles of freezing and thawing to which the tile shall be subjected are:

Class	Number of Cycles
Standard	36
Extra Quality	48
Heavy Duty	48
Extra Strength	48

13.4.2.5 At the end of each freeze-thaw cycle, visually inspect and note the condition of each specimen.

13.4.2.6 When the required number of freezing and thawing cycles has been completed, dry and weigh the specimens as in 12.3.1. Determine the loss in dry weight.

### 13.5 Calculation and Report:

13.5.1 Report the condition of each specimen as observed and noted at the end of the freezing and thawing test.

13.5.2 If breakage occurs in any specimen, report the number of cycles required to cause breakage.

13.5.3 If the specimen does not fail by breakage, calculate and report the percentage loss in dry weight of each specimen at the conclusion of 36 or 48 freezing and thawing cycles as appropriate for the class of tile.

13.5.4 Calculate and report the loss in dry weight for each of the five specimens.

### 13.6 Requirements:

13.6.1 No specimen shall break or show disintegration or spalling in the freezing and thawing test.

13.6.2 No specimen shall show a loss in dry weight greater than 5 % in the freezing and thawing test.

13.6.3 If all specimens meet the requirements of the freezing and thawing test, the absorption requirement of 6.2 shall be waived.

## 14. Field Inspection and Acceptance

14.1 The seller shall designate the lot of tile to be inspected.

14.2 Drain tile shall be subject to inspection by an inspector approved by the purchaser. The tile shall be inspected at the location and time agreed upon between the purchaser and the seller. The purpose of the inspection is to determine that visually, the tile are suitable for the intended use.

14.3 Drain tile, in a dry condition, shall give a clear ring when held free of the ground or tipped on edge and tapped with a hammer. The weight of the hammer head shall not exceed 4 oz (113 g).

14.4 All individual drain tile rejected shall be plainly marked by the inspector and shall be removed from the site by the seller, at the seller's expense.

## 15. Precision and Bias

15.1 No statements are made on the precision or bias of these test methods for measuring (1) crushing strength, (2) water absorption, (3) drying and saturation, and (4) freezing and thawing, since conformance to specific criteria is the only measure for success specified in these test methods.

## 16. Keywords

16.1 absorption; butt-end; clay; crushing strength; drain; drainage; filter field; freezing and thawing; inspection; leaching field; perforation; subdrainage; tile

## SUPPLEMENTARY REQUIREMENTS

The following supplementary requirements shall apply when material is supplied under this specification for U.S. Government procurement.

### S1. Packaging

S1.1 Unless otherwise specified in the contract, the material shall be packaged in accordance with the producer's standard practice which will be acceptable to the carrier at lowest rates. Containers and packing shall comply with Uniform Freight Classification Rules<sup>3</sup> or National Motor Freight Classification Rules.<sup>4</sup> Marking for shipment of such material shall be in accordance with Fed. Std. No. 123 for civil agencies and

MIL-STD-129 for military agencies.

### S2. Responsibility for Inspection

S2.1 Unless otherwise specified in the contract or purchase order, the producer is responsible for the testing of all material to ensure compliance with the requirements specified herein. Except as otherwise specified in the contract or order, the producer may use his own or any other suitable facilities for the performance of the inspection and test requirements specified herein, unless disapproved by the purchaser. The purchaser shall have the right to perform any of the inspections and tests set forth in this specification where such inspections are deemed necessary to ensure that material conforms to prescribed requirements.

---

<sup>3</sup> Available from The Uniform Classification Commission, Room 1106, 222 S. Riverside Plaza, Chicago, IL 60606.

<sup>4</sup> Available from National Motor Freight Inc., 1616 P. St., NW, Washington, DC 20036.

*The American Society for Testing and Materials takes no position respecting the validity of any patent rights asserted in connection with any item mentioned in this standard. Users of this standard are expressly advised that determination of the validity of any such patent rights, and the risk of infringement of such rights, are entirely their own responsibility.*

*This standard is subject to revision at any time by the responsible technical committee and must be reviewed every five years and if not revised, either reapproved or withdrawn. Your comments are invited either for revision of this standard or for additional standards and should be addressed to ASTM Headquarters. Your comments will receive careful consideration at a meeting of the responsible technical committee, which you may attend. If you feel that your comments have not received a fair hearing you should make your views known to the ASTM Committee on Standards, at the address shown below.*

*This standard is copyrighted by ASTM, 100 Barr Harbor Drive, PO Box C700, West Conshohocken, PA 19428-2959, United States. Individual reprints (single or multiple copies) of this standard may be obtained by contacting ASTM at the above address or at 610-832-9585 (phone), 610-832-9555 (fax), or service@astm.org (e-mail); or through the ASTM website (www.astm.org).*