



Designation: C 497 – 03

Standard Test Methods for Concrete Pipe, Manhole Sections, or Tile¹

This standard is issued under the fixed designation C 497; the number immediately following the designation indicates the year of original adoption or, in the case of revision, the year of last revision. A number in parentheses indicates the year of last reapproval. A superscript epsilon (ϵ) indicates an editorial change since the last revision or reapproval.

This standard has been approved for use by agencies of the Department of Defense.

1. Scope

1.1 These test methods cover testing of concrete pipe, manhole sections, and tile. The test methods described are used in production testing and acceptance testing to evaluate the properties provided for in the specifications.

1.2 The test methods appear in the following order:

	Section
External Load Crushing Strength	4
Flat Slab Top	5
Core Strength	6
Absorption	7
Hydrostatic	8
Permeability	9
Manhole Step	10
Cylinder Strength	11

1.3 The test specimens shall not have been exposed to a temperature below 40°F for the 24 h immediately preceding the test.

1.4 If any test specimen fails because of mechanical reasons such as failure of testing equipment or improper specimen preparation, it shall be discarded and another specimen taken.

1.5 Specimens shall be selected in accordance with the specifications for the type of pipe or tile being tested.

1.6 A complete metric companion to Test Methods C 497 has been developed—C 497M; therefore, no metric equivalents are presented in these methods.

1.7 *This standard does not purport to address all of the safety concerns, if any, associated with its use. It is the responsibility of the user of this standard to establish appropriate safety and health practices and determine the applicability of regulatory limitations prior to use.*

2. Referenced Documents

2.1 ASTM Standards:

C 31 Practice for Making and Curing Concrete Test Specimens in the Field²

C 39 Test Method for Compressive Strength of Cylindrical Concrete Specimens²

C 42 Test Method for Obtaining and Testing Drilled Cores and Sawed Beams of Concrete²

C 617 Practice for Capping Cylindrical Concrete Specimens²

C 670 Practice for Preparing Precision and Bias Statements for Test Methods for Construction Materials²

C 822 Terminology Relating to Concrete Pipe and Related Products³

C 1231 Practice for Use of Unbonded Caps in Determination of Compressive Strength of Hardened Concrete Cylinders²

D 2240 Test Method for Rubber Property-Durometer Hardness⁴

E 4 Practices for Force Verification of Testing Machines⁵

3. Terminology

3.1 *Definitions*—For definitions of terms relating to concrete pipe, see Terminology C 822.

4. External Load Crushing Strength Test by the Three-Edge Bearing Test Method

4.1 *Summary of Test Method*—The test specimen is tested in a machine designed to apply a crushing force upon the specimen in a plane through the vertical axis extending along the length of the specimen.

4.2 *Significance and Use*—The crushing test shall be either a quality control test performed to establish that the finished, shippable pipe has sufficient strength to withstand the crushing loads stated in the specifications or a proof of design test performed to prove the adequacy of design.

4.3 Apparatus:

4.3.1 The testing machine shall be of any type of sufficient capacity and shall be capable of providing the rate of loading prescribed in 4.5.3.

4.3.2 The testing machine shall be substantial and rigid throughout, so that the distribution of the load will not be affected appreciably by the deformation or yielding of any part.

4.3.3 The three-edge-bearing method of loading shall be used. The test specimen shall be supported on a lower bearing

¹ These test methods are under the jurisdiction of ASTM Committee C13 on Concrete Pipe and are the direct responsibility of Subcommittee C13.09 on Methods of Test.

Current edition approved Feb. 10, 2003. Published July 2003. Originally approved in 1962. Last previous edition approved in 2002 as C 497 – 02.

² *Annual Book of ASTM Standards*, Vol 04.02.

³ *Annual Book of ASTM Standards*, Vol 04.05.

⁴ *Annual Book of ASTM Standards*, Vol 09.01.

⁵ *Annual Book of ASTM Standards*, Vol 03.01.

of two parallel longitudinal strips and the load applied through an upper bearing (Figs. 1-4). At the option of the manufacturer, either or both the lower bearing and the upper bearing shall extend the full length or any portion of the length of the specimen. Fig. 5

4.3.4 The lower bearings shall consist of wood or hard rubber strips. Wooden strips shall be straight, have a cross section of not less than 2 in. in width and not less than 1 in. nor more than 1½ in. in height and shall have the top inside corners rounded to a radius of ½ in. Hard rubber strips shall have a durometer hardness of not less than 45 nor more than 60. They

shall be rectangular in cross section, having a width of not less than 2 in., a thickness of not less than 1 in. nor more than 1½ in., and shall have the top inside corner rounded to a radius of ½ in.

4.3.5 The lower bearing strips shall be fastened to a wooden or steel beam or directly to a concrete base, any of which shall provide sufficient rigidity so that deflection is not greater than 1/720 of the specimen length when the maximum load is applied. The rigid base shall be at least 6 in. wide. The interior vertical sides of the strips shall be parallel and spaced a distance apart of not more than 1 in./ft of specimen diameter, but in no case

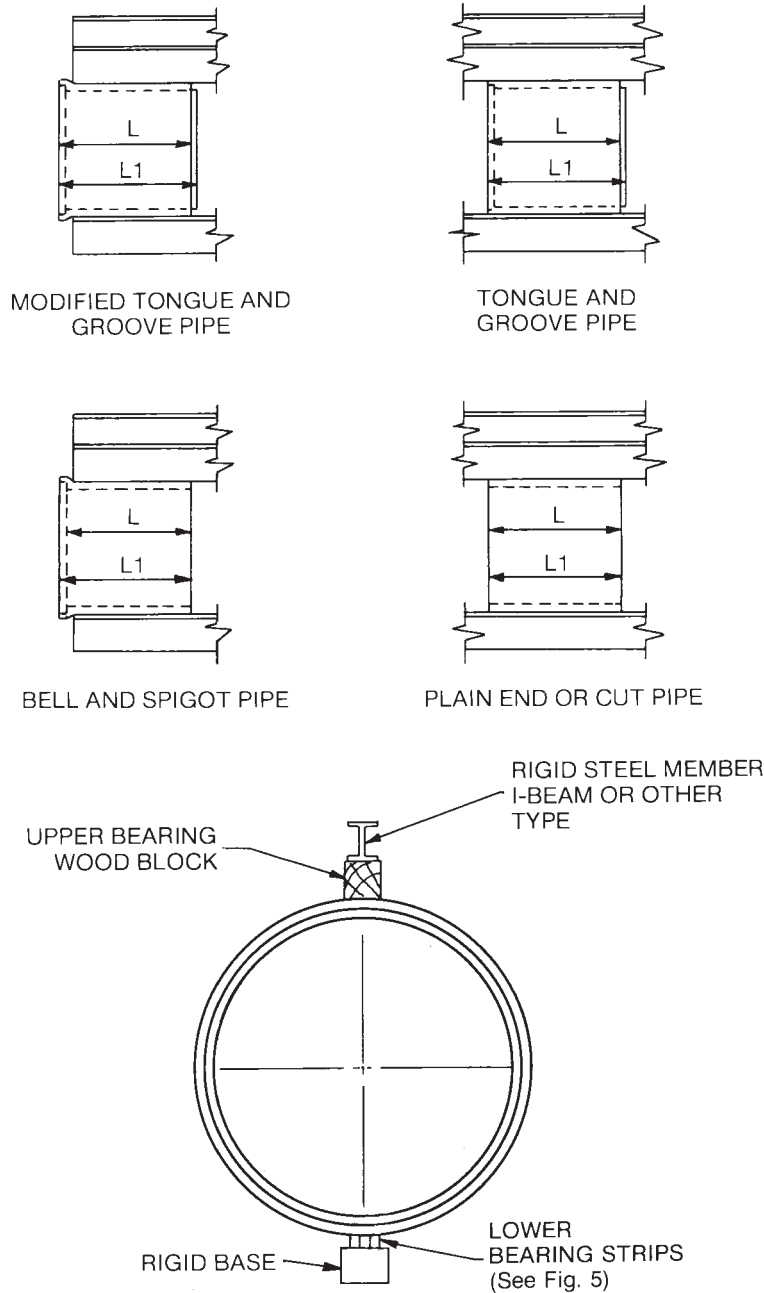

NOTE 1—The figures illustrate a method of applying the load to the pipe.

FIG. 1 Three-Edge-Bearing Test, Circular Pipe

ASTM C 497 – 03

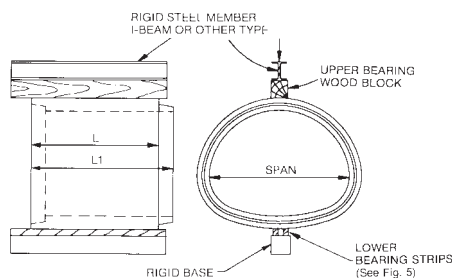

NOTE 1—The figure illustrates a method of applying the load to the pipe.

FIG. 2 Three-Edge-Bearing Test, Arch Pipe

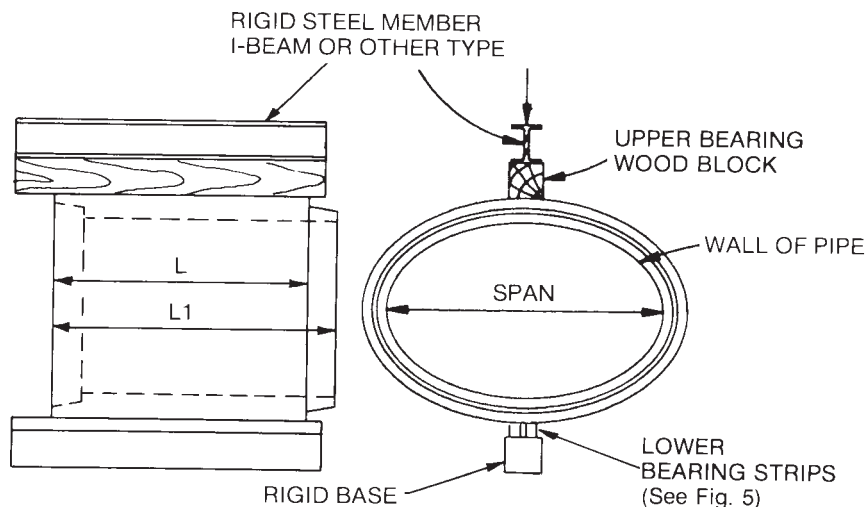

NOTE 1—The figure illustrates a method of applying the load to the pipe.

FIG. 3 Three-Edge-Bearing Test, Horizontal Elliptical Pipe

less than 1 in. The bearing faces of the lower strips shall not vary from a straight line vertically or horizontally by more than $\frac{1}{32}$ in./ft of length under no load.

4.3.6 The upper bearing shall be a rigid wood beam with or without an attached hard rubber strip. The wood shall be sound, free of knots, and straight and true from end to end. It shall be fastened to a steel or wood-faced steel beam of such dimensions that deflections under maximum load will not be greater than $\frac{1}{720}$ of the specimen length. The bearing face of the upper bearing shall not deviate from a straight line by more than $\frac{1}{32}$ in./ft of length. When a hard rubber strip is used on the bearing face it shall have a durometer hardness of not less than 45 nor more than 60, and shall have a width of not less than 2 in. and a thickness of not less than 1 in. nor more than $1\frac{1}{2}$ in. and shall be secured to a wood beam meeting the above requirements.

4.3.7 If mutually agreed upon by the manufacturer and the owner prior to the test, before the specimen is placed, a fillet of plaster of paris not exceeding 1 in. in thickness shall be cast on the surface of the upper and lower bearings. The width of the fillet cap, upper or lower, shall be not more than 1 in./ft of the specimen diameter, but in no case less than 1 in.

4.3.8 The equipment shall be so designed that the load will be distributed about the center of the overall length (L_1) of the specimen (Figs. 1-4). At the option of the manufacturer, the center of the load shall be applied at any point of the overall length (L_1) of the specimen. The load shall be applied either at

a single point or at multiple points dependent on the length of the specimen being tested and the rigidity of the test frame.

NOTE 1—The user of these test methods is advised that multiple points of load applications to the upper bearing will permit use of lighter beams without excessive deflection.

4.4 *Calibration*—The loading device shall be one which shall provide an accuracy of $\pm 2\%$ at the specified test loads. A calibration curve shall be used. The machines used for performing the three-edge-bearing tests shall be verified in accordance with Practices E 4.

4.5 *Procedure:*

4.5.1 Place the specimen on the two lower bearing strips in such a manner that the pipe or tile rests firmly and with uniform bearing on each strip.

4.5.2 Mark the two ends of the specimen at a point midway between the lower bearing strips and then establish the diametrically opposite point on each end. Place the upper bearing so that it is aligned with these marks.

4.5.3 For reinforced concrete pipe, any rate of load application up to a maximum of 7500 lbf/linear foot of pipe per minute shall be used up to 75 % of the specified design strength, at which time the rate of loading shall be reduced to a maximum uniform rate of $\frac{1}{3}$ of the specified design strength of the pipe per minute. This rate of loading shall be continuous until the specified acceptance design strength is reached. If

ASTM C 497 - 03

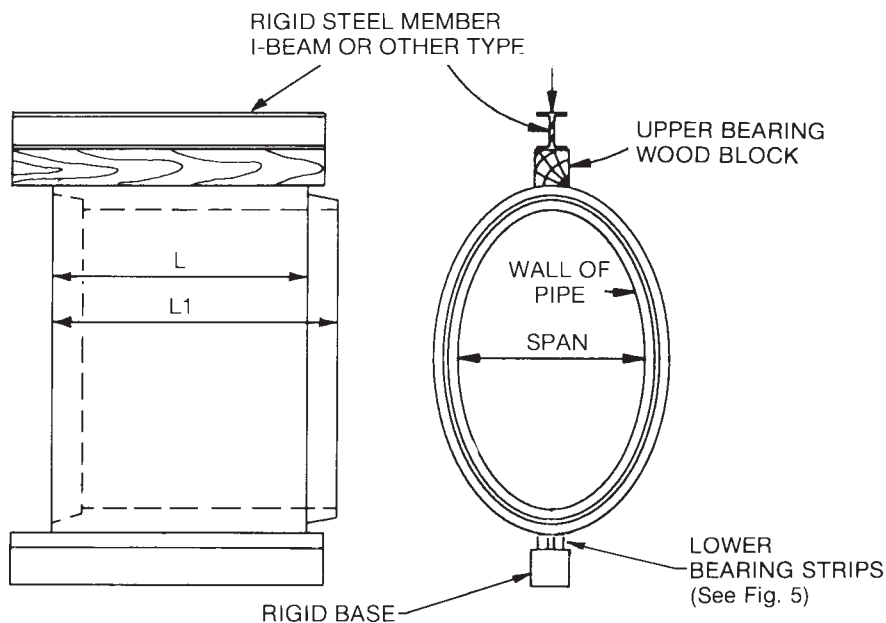

NOTE 1—The figure illustrates a method of applying the load to the pipe.

FIG. 4 Three-Edge-Bearing Test, Vertical Elliptical Pipe

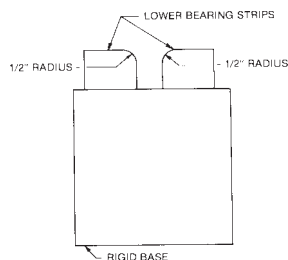

FIG. 5 Lower Bearing Strip Detail

4.5.4 As defined in Terminology C 822, the design strength is the maximum load, expressed as a D-load, supported by the pipe before a crack having a width of 0.01 in. occurs throughout a continuous length of 1 ft or more measured parallel to the longitudinal axis of pipe barrel. The crack is 0.01 in. in width when the point of the measuring gage will, without forcing, penetrate $\frac{1}{16}$ in. at close intervals throughout the specified distance of 1 ft. Measure the width of the crack by means of a gage made from a leaf 0.01 in. in thickness (as in a set of standard machinist gages), ground to a point of $\frac{1}{16}$ in. in width with corners rounded and with a taper of $\frac{1}{4}$ in./in. as shown in Fig. 6.

NOTE 2—As used in this specification, the 0.01-in. crack is a test criterion for pipe under load in three-edge bearing test and is not intended as an indication of overstressed or failed pipe under installed conditions.

4.5.5 As defined in Terminology C 822, the ultimate strength is the maximum load supported by the pipe.

NOTE 3—Ultimate strength of concrete pipe in the buried condition is dependent on varying soil bedding factors and varying failure modes and shall have no relationship to the ultimate strength as defined under three-edge bearing conditions.

both the design strength and the ultimate strength are being determined, a specified rate of loading need not be maintained after the acceptance design strength has been reached. For non-reinforced concrete pipe, any rate of load application up to a maximum of 7500 lbf/linear foot of pipe per minute shall be used up to 75 % of the specified ultimate strength, at which time the rate of loading shall be reduced to the maximum uniform rate of 3000 lbf/linear foot of pipe per minute. At the manufacturer's option, the rates of loading in this paragraph shall be any rates that do not exceed the specified maximums.

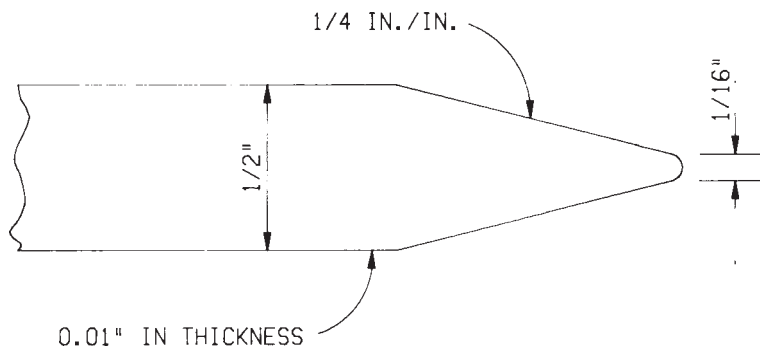

FIG. 6 Gage Leaf for Measuring Cracks

4.6 *Conditioning*—The moisture requirements of 1.3 are not required, at the option of the manufacturer.

4.7 *Calculations:*

4.7.1 Strength test results shall be calculated in terms of pounds per linear foot. The laying length used in calculating the strength values shall be that indicated by *L* in Figs. 1-4. For plain end pipe, no bell or spigot, the length *L* shall be the overall length. For pipe having a bell or spigot on one end with the opposite end being plain, *L* shall be the distance from the plain end to the center of the joint, where *L* equals the overall length minus ½ the depth of the bell, or the overall length minus ½ the length of the spigot.

4.7.2 The ultimate strength in pounds per linear foot shall be calculated by dividing the maximum test load applied to the pipe by the laying length *L*.

4.7.3 The D-load strength in pounds per linear foot per foot of inside diameter or horizontal span shall be either the 0.01-in. crack D-load strength or the ultimate D-load strength. The 0.01-in. crack D-load shall be calculated by dividing the test load required to produce the 0.01-in. crack by the laying length *L* and by the pipe inside diameter or horizontal span.

4.8 *Precision and Bias*—The user of these test methods is advised that the true value for the strength of a concrete pipe cannot be determined because the specimen is tested to destruction and exact duplicate specimen cannot be obtained. Therefore, no calculations of precision and bias are presently capable of being performed. Specifications that include this test method for the various types of concrete pipe should include a provision for additional tests of one or more specimens.

5. Flat Slab Top Test Method

5.1 *Summary of Test Method*—A load is applied to the flat slab top and the supporting capacity of the flat slab top is measured.

5.2 *Significance and Use*—The test method is a proof of design test performed to prove the adequacy of the design.

5.3 *Conditioning*—The moisture requirements of 1.3 are not required, at the option of the manufacturer.

5.4 *Procedure*—Place the section that has been designated to receive the flat slab top on a firm, even surface. Assemble the flat slab top to this section. If a frame or riser has been designed to be fitted to the access portion of the flat slab top, assemble

it to the slab top. Apply the test load to the riser or frame as assembled to the flat slab top. If no access opening has been provided to the flat slab top, apply the test load to the center of the flat slab top by means of a 12 by 12 by 4-in. wood bearing block. See Fig. 7. Calculate the test load as follows:

$$P_u = 1.3 D + 2.17L(1 + I) \tag{1}$$

where:

- P_u* = applied minimum ultimate proof-of-design test load, lb,
- D* = total calculated field dead load on the slab, lb,
- L* = calculated live load on the flat slab top, and
- I* = impact factor, 30 % minimum.

6. Core Strength Test Method

6.1 *Summary of Test Method*—The compressive strength of the concrete in the pipe is determined by making crushing tests of cores cut from the pipe.

6.2 *Significance and Use*—The core strength test is a quality control test performed to establish the fact that the finished, shippable precast concrete product had sufficient concrete strength to meet the strengths stated in the specifications.

6.3 *Apparatus*—A core drill shall be used for securing cylindrical core specimens from the wall of the pipe; a shot drill or a diamond drill shall be used.

6.4 *Test Specimens:*

6.4.1 A core specimen for the determination of compressive strength shall have a diameter at least three times the maximum size of the coarse aggregate used in the concrete. If cores are cut from the wall of the pipe and tested, the length to diameter ratio shall lie between one and two after the curved surfaces have been removed from the cut core.

6.4.2 *Moisture Conditioning*—Unless the agency for which the testing is being done directs otherwise, the core test specimens shall be submerged in lime-saturated water in accordance with the provisions of Test Method C 42.

6.5 *Procedure:*

6.5.1 *End Preparation and Capping*—Core specimens to be tested in compression shall have ends that are essentially smooth and perpendicular to the axis and of the same diameter as the body of the specimen. Before making the compression

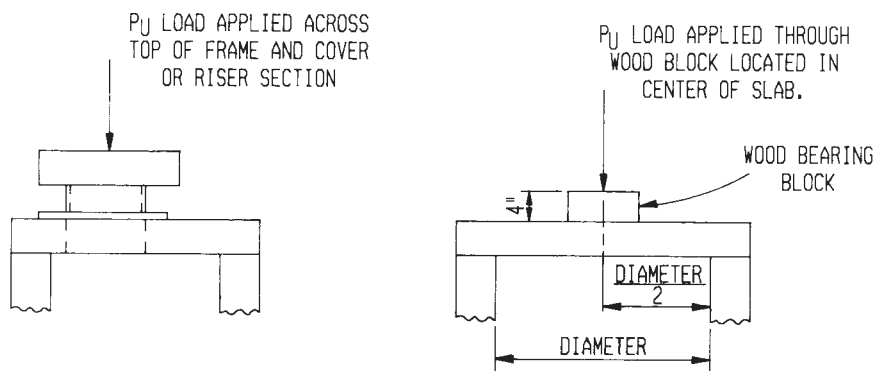

FLAT SLAB TOP WITH ACCESS OPENING FLAT SLAB TOP WITHOUT ACCESS OPENING
FIG. 7 Flat Slab Top Test

test, cap the ends of the specimen in order to meet the requirements of Practice C 617.

6.5.2 *Measurement*—Prior to testing, measure the length of the capped specimen to the nearest 0.1 in. and determine its average diameter to the nearest 0.1 in. from two measurements taken at right angles near the center of the length.

6.5.3 Test specimens as prescribed in Section 5 of Test Method C 39. See also Practice C 31.

6.6 *Calculation and Report*—Calculate the compressive strength of each specimen in pounds-force per square inch based on the average diameter of the specimen. If the ratio of length to diameter is less than two, make allowance for the ratio of length to diameter by multiplying the compressive strength by the applicable correction factor given in the following table (determine values not given in the table by interpolation):

Ratio Length of Cylinder to Diameter, l/d	Strength Correction Factor
1.75	0.98
1.50	0.96
1.25	0.94
1.10	0.90
1.00	0.85

6.7 *Precision and Bias*—The user of this test method is advised that this method for testing concrete pipe for strength is considered satisfactory for acceptance testing of commercial shipments since the test method has been used extensively for acceptance testing. In cases of disagreement arising from differences in values reported by the owner and the manufacturer when using this test method for acceptance testing, the statistical bias, if any, between the laboratory of the owner and the laboratory of the manufacturer should be determined with each comparison being based on testing specimens randomly drawn from one pipe of the type being evaluated.

7. Absorption Test Method

7.1 *Summary of Test Method*—This test method covers the testing of a specimen that is a sample or core from the wall of the pipe. The test specimen is first subjected to drying, then to immersion to determine the specimen's absorption of water when tested by the described procedures. Two alternative procedures for conducting the test are presented. Test Method A is the standard test and referee and will require 3 to 6 days to complete. Test Method B is intended as an accelerated test that requires about 1½ days to complete.

7.2 *Significance and Use*—The test method is a quality control test performed to establish the fact that the finished, shippable pipe meets the absorption limits stated in the specifications.

7.3 Test Specimens:

7.3.1 *Test Method A Specimens*—Test Method A absorption test specimens shall be in accordance with the requirements of the applicable pipe specification and shall be used for the absorption procedure that requires 5 h for boiling and a natural water cooling period of 14 to 24 h.

7.3.2 *Test Method B Specimens*—Test Method B absorption test specimens shall consist of three 1½-in. diameter cores as taken from the two ends and the center area of each tile, pipe, or section.

7.4 Procedure for Boiling Absorption Test Method:

7.4.1 *Drying Specimens*—Dry specimens in a ventilated mechanical convection oven at a temperature of 221 to 239°F.

7.4.1.1 *Test Method A*—Dry specimens until two successive weighings at intervals of not less than 6 h show an increment of loss not greater than 0.10 % of the last oven-dry mass of the specimen. Dry specimens with a wall thickness of 1.5 in. or less for a minimum of 24 h; dry specimens with a wall thickness of 1.5 to 3 in. for a minimum of 48 h; dry specimens with a wall thickness exceeding 3 in. for a minimum of 72 h. Use the last 6 h of the minimum drying time to determine whether or not the sample had obtained the proper dried mass.

7.4.1.2 *Test Method B*—Dry specimens for a minimum of 24 h.

7.4.2 *Weighing Dried Specimens*—Weigh the oven-dried specimens immediately upon removal from the oven where the drying temperature is 221 to 239°F.

7.4.3 Immersion and Boiling:

7.4.3.1 *Test Method A Specimen*—Within 24 h, carefully place the dried specimen that has been weighed in a suitable receptacle that contains clean water at a temperature of 50 to 75°F. Use distilled water, rain water, or tap water that is known to have no effect on test results. Heat the water to boiling in not less than 1 h and not more than 2 h. Do not apply live steam to the water to shorten the preboil period until 1 h of heating by gas or electricity has been completed. Continue the boiling for 5 h. At the end of the 5-h boiling period, turn off the heat, and allow the specimen to cool in the water to room temperature by natural loss of heat for not less than 14 h nor more than 24 h.

7.4.3.2 *Test Method B Specimen*—Within 24 h, carefully place the dried specimen that has been weighed in a suitable receptacle that contains clean water at a temperature of 50 to 75°F. Use distilled water, rain water, or tap water that is known to have no effect on test results. Heat the water to boiling in not less than 1 h and not more than 2 h. Do not apply live steam to the water to shorten the preboil periods until 1 h of heating by gas or electricity has been completed. Continue the boiling for 3 h. At the end of the 3-h boiling period, turn off the heat and cool the specimen for a period of 3 h by running cold tap water into the boiler, or by placing the specimen in a separate container of water. The temperature of the cooling water shall not exceed 65°F.

7.4.4 *Reweighing Wet Specimens*—Remove the water-cooled specimens from the water, place on an open drain rack, and allow to drain for 1 min. Remove the remaining superficial water by quickly blotting the specimen with a dry absorbent cloth or paper. Weigh the specimen immediately following blotting.

7.4.5 *Scale Sensitivity*—Weigh specimens weighing less than 1 kg to an accuracy of 0.10 % of the specimen mass. Weigh specimens weighing more than 1 kg to an accuracy of 1 g.

7.5 Calculation and Report:

7.5.1 *Test Method A Specimen*—Take the increase in mass of the boiled specimen over its dry mass as the absorption of the specimen, and express it as a percentage of the dry mass. Report the results separately for each specimen.

7.5.2 *Test Method B Specimen*—Take the increase in mass of the boiled specimen over its dry mass as the absorption of the specimen, and express it as a percentage of the dry mass. Report the result as an average of the three 1½-in. diameter cores as taken from one tile or pipe. The absorption, as calculated by the Test Method B procedure, shall be considered satisfactory when its value does not exceed a value that is 0.5 % less than the absorption designated in the Test Method A procedure. When the absorption, as computed by the Test Method B procedure, does not meet the specified requirement, the manufacturer is not permitted from performing a retest using Test Method A.

7.6 *Procedure for 10-Min Soaking Absorption Test*—Test specimens for the determination of the 10-min water soaking absorption shall be the same as are later used for the 5-h boiling absorption test. After drying and weighing as specified in 7.4.1 and 7.4.2, immerse the specimens in clear water for 10 min at room temperature. Then remove the specimens and weigh in accordance with 7.4.4, calculate the percentage absorption, and report in accordance with the provisions described in 7.5.

NOTE 4—There is no significant correlation between the results of this test and those of Test Method A or Test Method B.

7.7 *Precision and Bias*—The user of these test methods are advised of the following:

7.7.1 *Single-Operator Precision:*

7.7.1.1 *Test Method A*—The single operator standard deviation has been found to be 0.143 %. Therefore, results of two properly conducted tests by the same operator on the same material should not differ by more than 0.40 %.

7.7.1.2 *Test Method B*—The single operator standard deviation has been found to be 0.157 %. Therefore, results of two properly conducted tests by the same operator on the same material should not differ by more than 0.44 %.

NOTE 5—The numbers in 7.7.1.1 and 7.7.1.2 represent, respectively, the (1S) and (D2S) limits described in Practice C 670.

7.7.1.3 *10-Min Soak Test Method*—Precision for this test method has not been determined but is being investigated. A statement will be included when proper data have been collected and analyzed.

7.7.2 *Multilaboratory Precision*—Multilaboratory precision of Test Methods A, B, and the 10-min soak test method have not been determined but are being investigated. Statements will be included for each when the proper data have been obtained and analyzed.

7.7.3 *Bias*—Bias for Test Methods A, B, and the 10-min soak test method cannot be determined since the true value of absorption is not known and cannot be determined except by application of tests for which the bias is not known.

8. Hydrostatic Test Method

8.1 *Summary of Test Method*—The section of pipe or manhole is subjected to hydrostatic pressure and observed for leakage at the joint or on the surface of the wall. The joint is defined as a connection between the concrete section of pipe or manhole that provides alignment and the flexible watertight seal using either rubber gaskets, sealing bands, or preformed flexible joint sealant.

8.2 *Significance and Use*—The test method is a quality control test performed to establish the fact that the finished, shippable pipe or manhole meets the hydrostatic requirements stated in the specifications for the installed wall or joint, or both.

8.3 *Procedure:*

8.3.1 The equipment for making the test shall be such that, when the specimen under test is filled with water to the exclusion of air and subject to the required hydrostatic pressure, there shall not be enough leakage of water from the ends of the pipe to interfere with the test. The specimen under test shall be free of all visible moisture prior to the initiation of the test.

8.3.2 Do not test when the temperature of the specimen, the air around the specimen, or the water within the specimen is below 33°F.

8.3.3 If the joint seal or flexible connector is being tested, it shall be the sole element providing joint watertightness. No mortar or concrete coatings, fillings, or packing shall be used prior to the test.

8.3.4 Connect a standardized pressure gage to the specimen. If being tested in a vertical position, the gage shall be placed at or as close to as is practical above the joint or section being tested. If being tested in a horizontal position, the gage shall be placed to measure pressure at or as close to as practical above the horizontal axis. Raise the pressure of the water in approximately 1 min to the required level and hold for the specified time. There shall be no visible leakage. Moisture appearing in the form of patches or beads adhering to the surface shall not be considered leakage. If leakage occurs, the manufacturer is not prohibited from extending the soak time to 24 h.

8.4 *Precision and Bias*—No justifiable statement is presently capable of being made either on precision or on the bias of this method of testing for leakage under hydrostatic pressure since the test result merely states whether there is conformance to the criteria for success specified.

9. Permeability Test Method

9.1 *Summary of Test Method*—A section of pipe is kept filled with water for a specified time and the outer surface is tested for moisture.

9.2 *Significance and Use*—The test method is a quality control test performed to establish the fact that the finished, shippable pipe meets the leakage limits stated in the specifications.

9.3 *Procedure*—The pipe specimen under test shall be free of all visible moisture prior to the initiation of the test. Perform tests by placing the specimen to be tested, with the spigot end down on a soft rubber mat or its equivalent, weighted if necessary, and kept filled with water to a level of the base of the socket during the test period. Make the initial inspection approximately 15 min after the test has begun. If the pipe shows moist or damp spots on the outer surface of the pipe at that time, continue the tests for a period not to exceed 24 h at the option of the manufacturer. Examine the pipe during the extended period for existence of moist or damp spots.

9.4 *Precision and Bias*—No justifiable statement is presently capable of being made either on precision or on the bias

of this method of testing for leakage since the test result merely states whether there is conformance to the criteria for success specified.

10. Manhole Step Test Methods

10.1 *Summary of Test Method*—This test method determines the ability of an installed step to withstand a specified horizontal pull at right angles to the wall of a manhole riser or cone section, and then a vertical load parallel to the wall of the section.

10.2 *Significance and Use*—The manhole step tests are intended to be used for production control, lot acceptance, or adequacy of design. These tests are performed to establish whether or not the installed step has sufficient strength to withstand the specified loads.

10.3 *Apparatus*—In making the tests, any mechanical or hand powered devices which have calibrated load indicators attached shall be used. The attachments from the heads of each testing device to the rung of the step are to be sufficiently sturdy to preclude any bending of the attachment and rung over the length of the attachment. The attachments to the rung are to be 3½ in. in length.

10.4 *Conditioning*—The moisture requirements of 1.3 are not required, at the option of the manufacturer.

10.5 *Procedure*—It is not prohibited that the tests be made with the section to be tested placed on its side for easier access to the step to be tested. The first load shall be applied to the plane of the step by means of a pull-out device centered on the step rung and shall be applied at a uniform rate until the specified load is reached. The pull-out device is then removed and the test attachment is centered at the same location on the rung, and a second load is applied perpendicular to the plane of the first load application. The second load is applied at a uniform rate until the specified load is reached.

10.5.1 *Maximum Loads*—The first load as defined in 10.5 shall be 400 lb. The second load as defined in 10.5 shall be 800 lb.

10.6 *Precision and Bias*—No justifiable statement is presently capable of being made either on precision or bias of these methods of testing for strength since the test results merely state whether there is conformance to the criteria for success specified.

11. Cylinder Strength Test Method

11.1 *Summary of Test Method*—The concrete compressive strength of a concrete pipe, box section, or manhole is determined by making crushing tests of concrete cylinders.

11.2 *Significance and Use*—The concrete cylinder strength test is a quality control test performed to establish the fact that the finished, shippable precast concrete product had sufficient concrete compressive strength to meet the strengths stated in the specifications.

11.3 Test Specimens:

11.3.1 Cylinders shall be made, cured, and tested in accordance with Practice C 31 and Test Method C 39 or by methods comparable to those used to consolidate and cure the concrete in the manufactured concrete product. Cylinder specimens of sizes other than 6 by 12 in. are not prohibited, provided all other requirements of Practice C 31 are met.

11.3.2 If the concrete consistency is too stiff for compaction by rodding or internal vibrations, the following alternative method shall be used:

11.3.2.1 Attach a cylinder mold to the top of a vibrating table or to the actual concrete pipe form being used to produce the concrete product.

11.3.2.2 Place concrete in the cylinder mold in three equal lifts.

11.3.2.3 Place a cylindrical hammer on the surface of each lift with the hammer to be ¼ in. less in diameter than the inside diameter of the mold and of a weight to create a pressure of 0.353 psi on the surface of the concrete.

11.3.2.4 External vibration shall be applied on each lift with a frequency of at least 800 vibrations per minute, and continue the vibration until cement paste begins to ooze up around the bottom edge of the hammer.

11.4 Procedure:

11.4.1 *End Preparation and Capping*—Cylinder specimens to be tested in compression shall have ends that are essentially smooth and perpendicular to the axis and of the same diameter as the body of the specimen. Before making the compression test, cap the ends of the specimen to meet the requirements of Practice C 617 or Practice C 1231.

11.4.2 *Testing*—Test specimens as prescribed in Test Method C 39.

11.5 *Calculation and Report*—Calculate the compressive strength of each specimen in pounds-force per square inch based on the average diameter of the specimen.

11.6 *Precision and Bias*—The user of this specification is advised that this method of testing concrete products for concrete compressive strength is considered satisfactory for acceptance testing of commercial shipments since the test method has been used extensively for acceptance testing. In cases of disagreement arising from differences in values reported by the owner and the manufacturer when using this method for acceptance testing, the statistical bias, if any, between the laboratory of the owner and the laboratory of the manufacturer should be determined with each comparison being based on testing specimens randomly selected from the specimens available for the type of concrete product being evaluated.

12. Gasket Lubricant Tests

12.1 The lubricant manufacturer shall be responsible for all testing.

12.2 Durometer and Volume Change Tests:

12.2.1 The concrete pipe manufacturer or the gasket manufacturer shall supply the lubricant manufacturer with a minimum of three samples of each gasket material used by the pipe manufacturer.

12.2.2 Measure 2-in. samples from each gasket type for volume. The durometer shall be checked in accordance with Test Method D 2240. The samples shall be immersed in lubricant in a closed container.

12.2.3 The immersed samples shall be held at 70°F for a period of three days.

12.2.4 At the end of the three day period, the volume of the samples shall be re-measured and the durometer of the samples rechecked in accordance with Test Method D 2440.

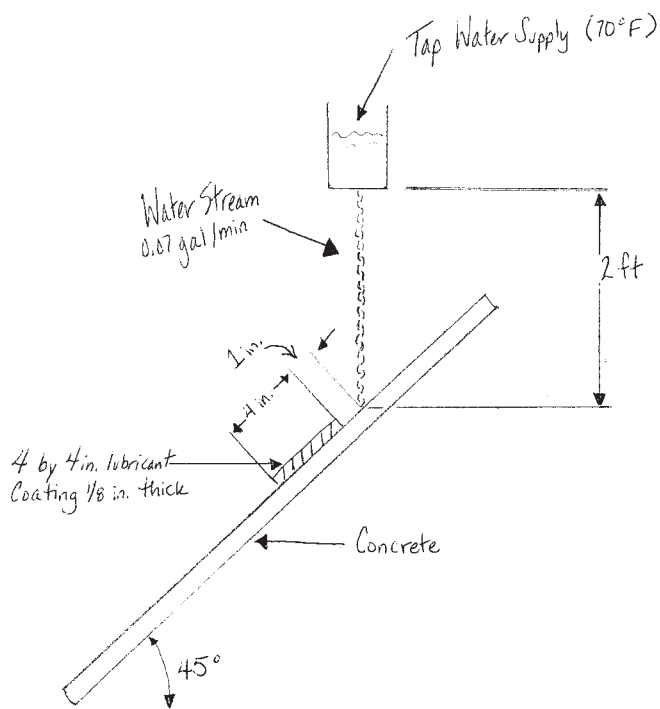

FIG. 8 Lubricant Wash Test

12.3 Wash Test for Subaqueous Lubricants:

12.3.1 A clean piece of concrete from the pipe shall be thoroughly wetted and then coated with a 1/8 in. layer of lubricant covering an area of 4 by 4 in.

12.3.2 The prepared specimen shall then be washed for 5 min with a soft stream (250 mL/min) of tap water (70°F) from a height of 2 ft using equipment as shown in Fig. 8.

12.3.3 After air drying, the washed off area shall be divided by the original coated area and multiplied by one hundred and the result is the percent washed-away.

12.4 Certification:

12.4.1 The lubricant manufacturer shall supply the purchaser written certification that the gasket lubricant has met all test requirements specified to the gasket samples supplied.

12.4.2 Tests shall be performed each year on a gasket lubricant for certification, which shall be valid for one year provided there are no changes in the materials or process used in the manufacture of either the gaskets or the lubricant.

12.4.3 No gasket lubricant shall be used on concrete pipe joints meeting this specification without valid certification provided to the concrete pipe manufacturer.

12.5 Marking:

12.5.1 The following information shall be clearly marked on each container of lubricant supplied to the pipe manufacturer.

- 12.5.1.1 Name of lubricant manufacturer.
- 12.5.1.2 Usable temperature range.
- 12.5.1.3 Shelf life.
- 12.5.1.4 Lot or batch number.

13. Measurement of Rubber Gasket Volume and Dimensions

NOTE 6—These are measurements performed by the pipe manufacturer for quality control checks.

13.1 *Volume*—This method is used to determine the volume of a pipe gasket. Measure the mass of the gasket to the nearest gram. Next, immerse the gasket completely in water and measure the mass of the gasket while totally submerged. A surfactant shall be added to the water to minimize air bubbles from clinging to the gasket material. The difference in the dry mass and the immersed mass of the gasket, measured in grams, is the volume of the gasket in cubic centimeters.

13.1.1 As an alternate to the above, the gasket shall be placed in a water tank and the displaced water shall be collected. The volume of water is then measured directly in cubic centimeters or by pouring into a calibrated tube or the water displaced shall be weighed. One gram of water equals one cubic centimeter.

13.2 *Unstretched Length*—This method is used to determine the unstretched length of a pipe gasket. Construct a flat, straight calibrated measuring scale such as a measuring tape attached to a table or the floor. Make an index mark on the gasket cross-section with the flat side down (or out). Place the gasket index mark at the zero point on the measuring scale and carefully roll the uncut gasket loop without sliding or stretching. The gasket length is the distance measured at the point where the index mark retouches the scale.

13.3 *Height of Profile Gasket*—These methods are used to determine the profile gasket height, while stretched to the design strain of the proposed joint geometry for which the gasket is to be utilized.

13.3.1 *Method 1*—This method requires a precise measuring device mounted on a rigid fixture attached to the pipe joint (see Fig. 9).

13.3.1.1 Install the test gasket at the location on the joint that is designated by the joint data sheet. Equalize the gasket stretch according to the gasket manufacturer's recommendations.

13.3.1.2 Carefully measure the distance to the highest sealing surface of the gasket. For self-lubricating gaskets, the tube containing the lubricant must be rolled over the gasket body and held under slight pressure as the measurement is taken. Without disturbing the measuring device, slide the gasket out of the joint recess toward the pipe barrel. Measure the point on the joint gasket-bearing surface immediately under the point where the gasket measurement was taken. The difference in measurements is the stretched gasket height.

13.3.2 *Method 2*—Position the gasket or a segment of a gasket in the same orientation that the cross-section is to be installed on the pipe joint. Make two index marks 12 in. apart on a straightened, but nonstretched segment of gasket. With an axial force, elongate the gasket until the distance between the marks is equal to $12[(100\% + \% \text{ design stretch})/100]$. Hold or clamp the gasket segment in the stretched position. Measure the distance between the two sealing surfaces of the gasket with a vernier, micrometer, or dial gauge.

14. Joint Shear Test

14.1 *Summary of Test Method*—A shear force, normal to the longitudinal axis of the pipes, is applied across the assembled joint between two concrete pipes.

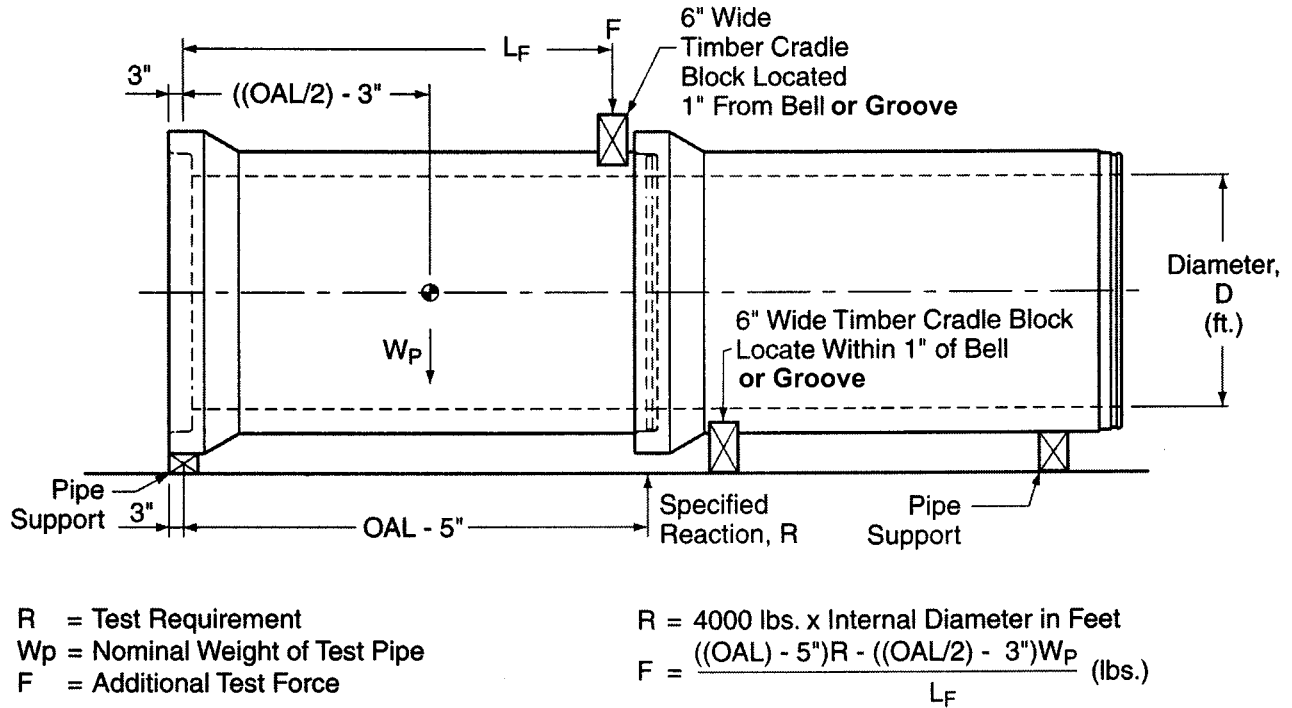

FIG. 9 Joint Shear Test

14.2 *Significance and Use*—This is a proof-of-design test that evaluates the structural capability of the pipe joint when subjected to a differential load.

14.3 *Apparatus:*

14.3.1 The testing machine shall be of any type that has sufficient capacity to apply the required test load or a suitable dead load shall be applied. The applied force shall not be less than the required force by more than 2 %.

14.3.2 Supporting timber cradle blocks, with one face curved to match the outer diameter of the pipe barrel, shall be used to transmit the shear force from the test apparatus to the test pipe joint. The curved face shall be lined with a 1-in. thick

hard rubber strip. Additional timber blocks or similar supports are necessary to elevate the test pipes. At the manufacturers option, it is permissible to use flat timbers in lieu of cradle blocks.

14.4 *Procedure:*

14.4.1 To perform the test, two test pipes shall be assembled with one pipe fully supported and the spigot or tongue end of the second pipe installed in the bell or groove end of the first pipe as illustrated in Fig. 10. Both pipes shall be supported so a uniform invert elevation is maintained. The user of this specification is advised that for safety reasons the pipe supports shall be constructed as shown in Fig. 10.

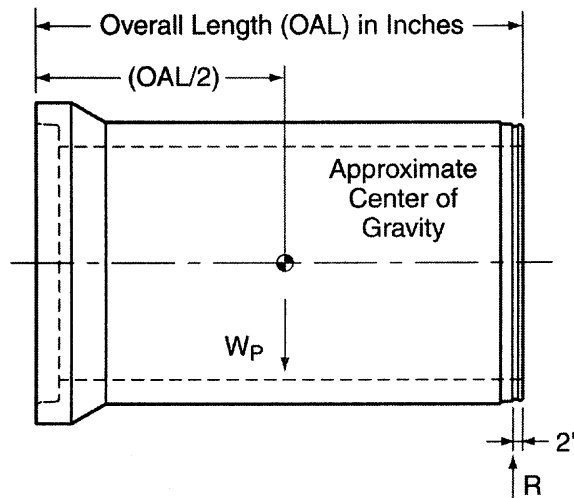

FIG. 10 Simplified Center of Gravity of Pipe

14.4.2 **Warning**—Block or restrain the test pipe assembly horizontally to prevent any inadvertent pipe movements. The blocking or restraints shall be designed to avoid beneficial effects on the test.

14.4.3 The joint shear test shall be run without water in the pipe or bulkheads installed on the pipe. A vertical test load (F) shall be applied to the suspended portion of the test joint until the total differential load, including the weight of a pipe, is 4000 lbf-ft of pipe diameter.

NOTE 7—The manufacturer shall have the option to conduct concurrently a hydrostatic test and this structural test. If proven watertight under these combined conditions, hairline cracks that do not leak shall not be cause for rejection.

14.4.4 The test load shall be applied to the unsupported spigot of the test joint until the force reaches 4000 lbf-ft for no less than 1 min or the joint reaches the limit of its shear strength. The shear strength limit shall be noted by a sudden reduction in the applied load or shearing of the concrete.

NOTE 8—This is also a quality control test result for the lowest concrete strength and lowest class of pipe produced.

14.4.5 Cracks that occur during the test load are not considered failure, provided those cracks close to a width of less than 0.01 in. on release of the load.

14.5 Calculations:

14.5.1 The shear force resisted by the test joint shall be calculated by the resolution of applied and gravity forces on the pipe section. The total shear force on the joint is the sum of the resultants of the pipe weight and the applied force. (See Figs. 10 and 11.)

14.6 *Precision and Bias*—The differential shear test provides an objective value of the structural strength of a concrete pipe joint. There is no widely accepted method of analysis for differential shear through the joints in buried concrete pipes. All current methods of concrete pipe design assume that the installed pipes are uniformly bedded along the length of the pipeline. Stronger joints will resist greater flaws in subgrade design or installation.

15. Alkalinity of Concrete Mixture

15.1 *Summary of Test Method*—This test method compares the ability of a sample of powdered, hardened concrete and pure calcium carbonate to neutralize acid. The concrete alkalinity is the ratio of the mass of acid neutralized by powdered concrete divided by the mass of acid neutralized by a similar sample of pure calcium carbonate.

15.2 *Significance and Use*—The user of this specification is advised that this is a proof-of-design test that evaluates the ability of the concrete mixture used in concrete pipes to resist the attack of acids that at times can form in sanitary sewers. The alkalinity rating of the concrete mixture is one of the design criteria used to predict the service life of concrete pipelines where hydrogen sulfide may be generated.

15.3 Apparatus:

15.3.1 One method of extracting powdered concrete samples is by use of a rotary drill with a twist bit.

15.3.2 A buret is required to complete the titration process on the concrete and calcium carbonate samples.

15.4 Procedure:

15.4.1 Samples of concrete from a pipe are obtained by drilling two one inch diameter cores from the interior pipe wall to the depth of the reinforcement. Each core sample is then placed in a separate container and dried in an oven for one to two hours at a temperature between 212 and 230°F. The samples are then pulverized to obtain 100 % passing a 100-mesh sieve.

15.4.2 Place approximately 1 g of a sample into a beaker and add 10 mL of water. Next, slowly add 40 mL of standard 1-Normal hydrochloric acid, HCl, to the sample and water. When the effervescence has subsided, heat the mixture to boiling. Continue to boil for 30 s, and then cool.

15.4.3 Add 50 to 100 mL of water to the cooled mixture and titrate with a carbonate free standard 1-Normal sodium hydroxide, NaOH, solution. Titrate the mixture until the pH stays above 6.8 for 2 min. The final pH shall be between 6.8 and 7.8. Run two tests on each core sample.

15.5 Calculations:

15.5.1 The alkalinity of the material is the average of all samples.

15.5.2 The net calcium carbonate equivalent of the sample is:

$$\text{CaCO}_3 \text{ Equivalent} = \frac{5[(\text{mL of HCl}) - (\text{mL of NaOH})]}{[\text{sample mass in grams}]} \quad (2)$$

16. Measurement of Rubber Gasket Volume and Dimensions

NOTE 9—These are measurements performed by the pipe manufacturer for quality control checks.

16.1 *Volume*—This method is used to determine the volume of a solid, circular cross section pipe gasket. Measure the mass of the gasket to the nearest gram. Next, immerse the gasket completely in water and measure the mass of the gasket while totally submerged. A surfactant shall be added to the water to minimize air bubbles from clinging to the gasket material. The difference in the dry mass and the immersed mass of the gasket, measured in grams, is the volume of the gasket in cubic centimeters. As an alternate to the above, the gasket shall be placed in a water tank and the displaced water shall be collected. The volume of water is then measured directly in cubic centimeters or by pouring into a calibrated tube or the water displaced shall be weighed. 1 g of water equals 1 cm³.

16.2 *Unstretched Length*—This method is used to determine the unstretched length of a pipe gasket. Construct a flat, straight calibrated measuring scale such as a measuring tape attached to a table or the floor. Make an index mark on the gasket cross-section with the flat side down (or out). Place the gasket index mark at the zero point on the measuring scale and carefully roll the uncut gasket loop without sliding or stretching. The gasket length is the distance measured at the point where the index mark retouches the scale.

16.3 *Height of Profile Gasket*—These methods are used to determine the profile gasket height, while stretched to the design strain of the proposed joint geometry for which the gasket is to be utilized.

16.3.1 *Method 1*—This method requires a precise measuring device mounted on a rigid fixture attached to the pipe joint (see Fig. 11). Install the test gasket at the location on the joint

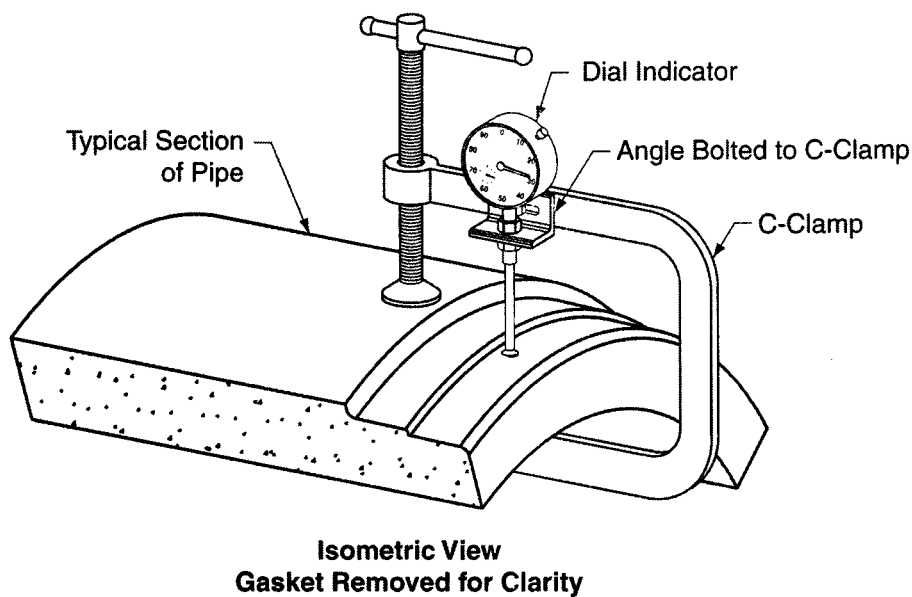
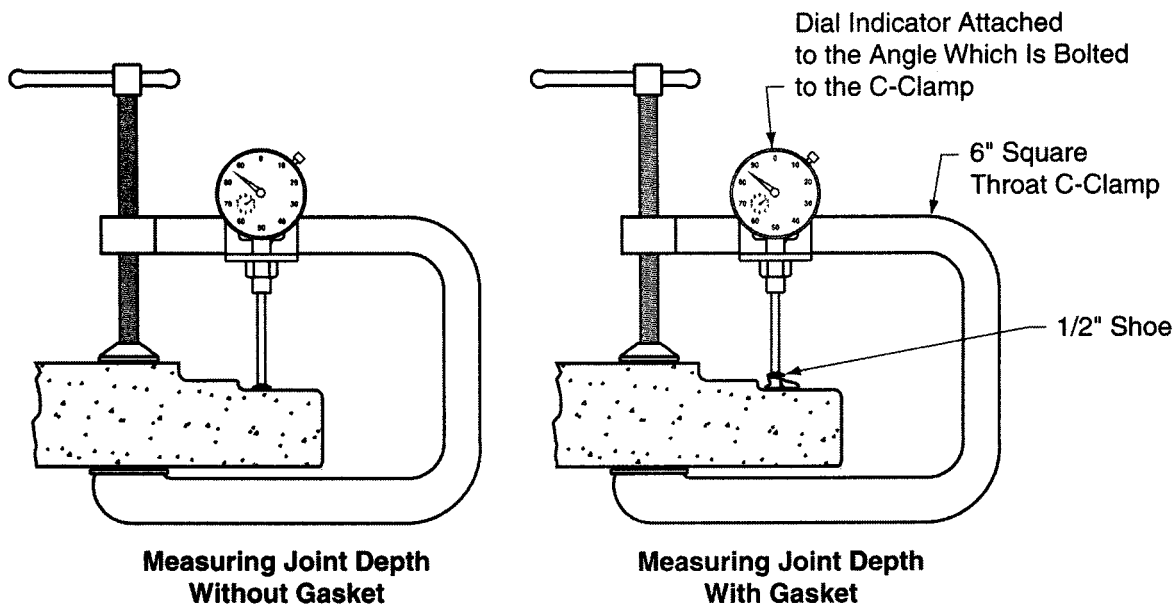

FIG. 11 Dial Indicator

that is designated by the joint data sheet. Equalize the gasket stretch according to the gasket manufacturer's recommendations. Carefully measure the distance to the highest sealing surface of the gasket. For self-lubricating gaskets, the tube containing the lubricant must be rolled over the gasket body and held under slight pressure as the measurement is taken. Without disturbing the measuring device, slide the gasket out of the joint recess. Measure the point on the joint gasket-bearing surface immediately under the point where the gasket measurement was taken. The difference in measurements is the stretched gasket height.

16.3.2 *Method 2*—Position the gasket or a segment of a gasket in the same orientation that the cross-section is to be installed on the pipe joint. Make two index marks 12 in. apart on a straightened, but nonstretched segment of gasket. With an axial force, elongate the gasket until the distance between the marks is equal to $12[(100\% + \% \text{design stretch})/100]$. Hold or clamp the gasket segment in the stretched position. Measure the distance between the two sealing surfaces of the gasket with a vernier, micrometer, or dial gage.

**NOTICE: This standard has either been superseded and replaced by a new version or discontinued.
Contact ASTM International (www.astm.org) for the latest information.**



ASTM International takes no position respecting the validity of any patent rights asserted in connection with any item mentioned in this standard. Users of this standard are expressly advised that determination of the validity of any such patent rights, and the risk of infringement of such rights, are entirely their own responsibility.

This standard is subject to revision at any time by the responsible technical committee and must be reviewed every five years and if not revised, either reapproved or withdrawn. Your comments are invited either for revision of this standard or for additional standards and should be addressed to ASTM International Headquarters. Your comments will receive careful consideration at a meeting of the responsible technical committee, which you may attend. If you feel that your comments have not received a fair hearing you should make your views known to the ASTM Committee on Standards, at the address shown below.

This standard is copyrighted by ASTM International, 100 Barr Harbor Drive, PO Box C700, West Conshohocken, PA 19428-2959, United States. Individual reprints (single or multiple copies) of this standard may be obtained by contacting ASTM at the above address or at 610-832-9585 (phone), 610-832-9555 (fax), or service@astm.org (e-mail); or through the ASTM website (www.astm.org).