



Designation: **C 652 – 01a<sub>4</sub>**

## Standard Specification for Hollow Brick (Hollow Masonry Units Made From Clay or Shale)<sup>1</sup>

This standard is issued under the fixed designation C 652; the number immediately following the designation indicates the year of original adoption or, in the case of revision, the year of last revision. A number in parentheses indicates the year of last reapproval. A superscript epsilon (ε) indicates an editorial change since the last revision or reapproval.

*This standard has been approved for use by agencies of the Department of Defense.*

### 1. Scope\*

1.1 This specification covers hollow building brick and hollow facing brick made from clay, shale, fire clay, or mixtures thereof, and fired to incipient fusion. Four types of hollow brick in each of two grades and two classes are covered. In this specification the term hollow brick shall be understood to mean hollow clay masonry units whose net cross-sectional area (solid area) in any plane parallel to the surface, containing the cores, cells, or deep frogs, is less than 75 % of its gross cross-sectional area measured in the same plane (see 3.3). This specification does not cover brick intended for use as paving brick (see Specification C 902).

1.2 The property requirements of this standard apply at the time of purchase. The use of results from testing of brick extracted from masonry structures for determining conformance or nonconformance to the property requirements (Section 5) of this standard is beyond the scope of this standard.

1.3 Brick covered by this specification are manufactured from clay, shale, or similar naturally occurring substances and subjected to a heat treatment at elevated temperatures (firing). The heat treatment shall develop sufficient fired bond between the particulate constituents to provide the strength and durability requirements of this specification. (See “firing” and “firing bond” in Terminology C 43.)

1.4 Hollow brick differ from unglazed structural clay tile (Specifications C 34 and C 212) and solid brick (Specifications C 62 and C 216). Hollow brick require greater shell and web thicknesses and higher minimum compressive strength than structural clay tile, but permit greater void area and lesser distance from exposed edge to core hole than solid brick. Therefore, environmental and structural performance may be different in elements constructed of hollow brick from those constructed of structural clay tile or solid brick.

1.5 The text of this standard references notes and footnotes which provide explanatory material. These notes and footnotes (excluding those in tables and figures) shall not be considered as requirements of the standard.

1.6 The values stated in inch-pound units are to be regarded as the standard. The values given in parentheses are for information only.

---

<sup>1</sup> This specification is under the jurisdiction of ASTM Committee C15 on Manufactured Masonry Units and is the direct responsibility of Subcommittee C15.02 on Brick and Structural Clay Tile.

Current edition approved ~~Sept. 10, 2001~~; January 1, 2004. Published ~~November 2001~~; February 1, 2004. Originally published as ~~C 652-70~~; approved in 1970. Last previous edition approved in 2001 as C 652-01a.

\*A Summary of Changes section appears at the end of this standard.

## 2. Referenced Documents

### 2.1 ASTM Standards: <sup>2</sup>

- C 34 Specification for Structural Clay Load-Bearing Wall Tile
- C 43 Terminology of Structural Clay Products
- C 62 Specification for Building Brick (Solid Masonry Units Made from Clay or Shale)
- C 67 Test Methods for Sampling and Testing Brick and Structural Clay Tile
- C 212 Specification for Structural Clay Facing Tile
- C 216 Specification for Facing Brick (Solid Masonry Units Made from Clay or Shale)
- C 902 Specification for Pedestrian and Light Traffic Paving Brick
- E 835/E 835M Guide for Modular Coordination of Clay and Concrete Masonry Units

## 3. Classification

### 3.1 Grades—Two grades of hollow brick are covered:

3.1.1 *Grade SW*—Hollow brick intended for use where a high and uniform degree of resistance to frost action and disintegration by weathering is desired and the exposure is such that the hollow brick may be frozen when permeated with water.

3.1.2 *Grade MW*—Hollow brick intended for use where a moderate and somewhat nonuniform degree of resistance to frost action is permissible or where they are unlikely to be permeated with water when exposed to temperatures below freezing.

### 3.2 Types—Four types of hollow brick are covered:

3.2.1 *Type HBS*—Hollow brick for general use in masonry.

3.2.2 *Type HBX*—Hollow brick for general use in masonry where a higher degree of precision and lower permissible variation in size than permitted for Type HBS is required.

3.2.3 *Type HBA*—Hollow brick for general use in masonry selected to produce characteristic architectural effects resulting from nonuniformity in size and texture of the individual units.

3.2.4 *Type HBB*—Hollow brick for general use in masonry where a particular color, texture, finish, uniformity, or limits on cracks, warpage, or other imperfections detracting from the appearance are not a consideration.

3.2.5 When the type is not specified, the requirements for Type HBS shall govern.

### 3.3 Class—Two classes of hollow brick are covered:

3.3.1 *Class H40V*—Hollow brick intended for use where void areas or hollow spaces greater than 25 %, but not greater than 40 %, of the gross cross-sectional area of the unit measured in any plane parallel to the surface containing the cores, cells, or deep frogs are desired. The void spaces, the web thicknesses, and the shell thicknesses shall comply with the requirements of Section 10 on Hollow Spaces.

3.3.2 *Class H60V*—Hollow brick intended for use where larger void areas are desired. The sum of these void areas shall be greater than 40 %, but not greater than 60 %, of the gross cross-sectional area of the unit measured in any plane parallel to the surface containing the cores, cells or deep frogs. The void spaces, the web thicknesses, and the shell thicknesses shall comply with the requirements of Section 10 on Hollow Spaces and to the minimum requirements contained in Table 1 (see Fig. 1).

3.3.3 When the class is not specified, the requirements of class H40V shall govern.

## 4. Materials and Manufacture

4.1 The body of all hollow brick shall be of clay, shale, fire clay, or mixtures of these materials, with or without admixtures, burned to meet the requirements of this specification. Any coloring or other materials added to the clay shall be suitable ceramic materials and shall be well distributed throughout the body. Unless otherwise specified by the purchaser, surface coloring shall not be applied to any brick other than by sanding or flashing.

## 5. Physical Properties

5.1 *Durability*—When Grade is not specified, the requirements for Grade SW shall govern. ~~Unless otherwise specified by the purchaser, brick of Grade SW shall be accepted instead of Grade MW. govern.~~

5.1.1 *Physical Property Requirements* —The brick shall conform to the physical requirements for the Grade specified as prescribed in Table 2. For the compressive strength requirements in Table 2, test the unit with the compressive force perpendicular

**TABLE 1 Class H60V—Hollow Brick Minimum Thickness of Face Shells and Webs, in. (mm)**

Nominal Width of Units	Face Shell Thicknesses		End Shells or End Webs
	Solid	Cored or Double Shell	
3 and 4 (76 and 101)	¾ (19.05)	...	¾ (19.05)
6 (152)	1 (25.4)	1½ (38)	1 (25.4)
8 (203)	1¼ (32)	1½ (38)	1 (25.4)
10 (254)	1⅝ (35)	1⅝ (41)	1⅝ (29.5)
12 (306)	1½ (38)	2 (50)	1⅝ (29.5)

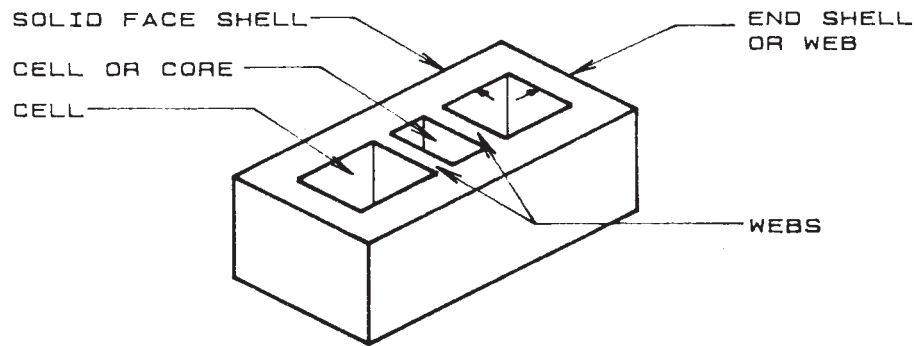

**SOLID SHELL HOLLOW BRICK UNITS**

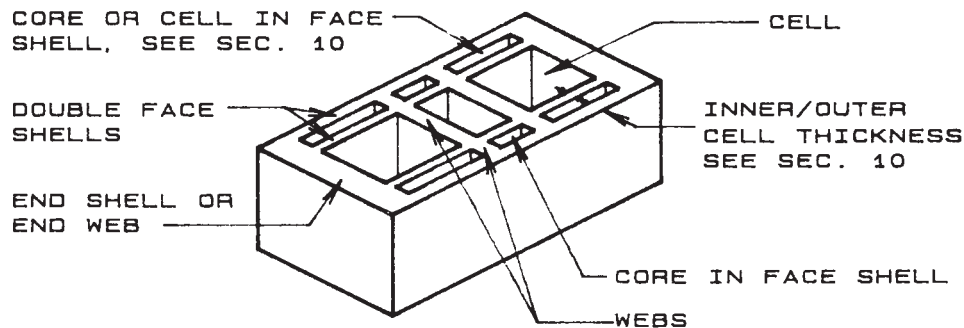

**DOUBLE SHELL HOLLOW BRICK UNITS**

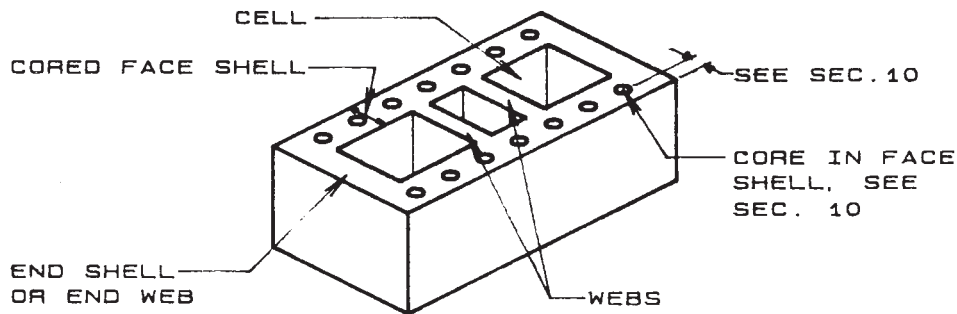

**CORED SHELL HOLLOW BRICK UNITS**

FOR MINIMUM DIMENSIONS SEE SECTION 10 AND TABLE 5  
**FIG. 1 Hollow Brick Units**

**TABLE 2 Physical Requirements**

Designation	Compressive Strength gross area, min, psi (MPa)		Water Absorption by 5-h Boiling, max, %		Saturation Coefficient, max	
	Average of 5 brick	Individual	Average of 5 brick	Indi- vidual	Average of 5 brick	Indi- vidual
	Grade SW	3000 (20.7)	2500 (17.2)	17.0	20.0	0.78
Grade MW	2500 (17.2)	2200 (15.2)	22.0	25.0	0.88	0.90

to the bed surface of the unit, with the unit in the stretcher position.

5.1.2 *Absorption Alternate*—The saturation coefficient requirement does not apply, provided the 24-h cold water absorption of each unit of a random sample of five brick does not exceed 8.0 %.

5.1.3 *Freezing and Thawing Alternative* —The requirements for 5 h boiling water absorption and saturation coefficient do not apply, provided a sample of five brick, meeting the strength requirements of Table 2, passes the freezing and thawing test as described in the Rating Section of the Freezing and Thawing test procedures of Test Methods C 67.

5.1.3.1 *Grade SW: Weight Loss Requirement* —Not greater than 0.5 % loss in dry weight of any individual unit.

NOTE 1—The 50 cycle freezing and thawing test is used as an alternative only when the brick do not conform to either Table 2 requirements for maximum water absorption and saturation coefficient, or to the requirements of the Absorption Alternate in Section 5.1.2.

5.1.3.2 *Grade SW: Breakage Requirement*—No individual unit separates into two or more significant pieces.

5.1.3.3 *Grade SW: Cracking Requirement*—No individual unit develops a crack that exceeds, in length, the unit’s least dimension.

5.2 *Strength*—When hollow brick are required having strengths greater than prescribed in Table 2, the purchaser shall specify the desired minimum compressive strength.

5.3 *Initial Rate of Absorption (IRA)*—Test results for IRA shall be determined in accordance with Section 9 of Test Methods C 67 and shall be furnished at the request of the specifier or purchaser. IRA is not a qualifying condition or property of units in this specification. This property is measured in order to assist in mortar selection and material handling in the construction process. See Note 2.

NOTE 2—*Initial Rate of Absorption (Suction)*—Both laboratory and field investigation have shown that strong and watertight joints between mortar and masonry units are not achieved by ordinary construction methods when the units as laid have excessive initial rates of absorption. Mortar that has stiffened somewhat because of excessive loss of mixing water to a unit may not make complete and intimate contact with the second unit, resulting in poor adhesion, incomplete bond, and water-permeable joints of low strength. IRA of the units is determined by the oven-dried procedure described in the IRA (Suction) (Laboratory Test) of Test Methods C 67. IRA in the field depends on the moisture content of the masonry unit and is determined in accordance with the IRA (Suction)—Field Test of Test Methods C 67. Units having average field IRA exceeding 30 g/min per 30 in.<sup>2</sup> (30 g/min 194 cm<sup>2</sup>) should have their IRA reduced below 30 g/min per 30 in.<sup>2</sup> prior to laying. They may be wetted immediately before they are laid, but it is preferable to wet them thoroughly 3 to 24 h prior to their use so as to allow time for moisture to become distributed throughout the unit.

## 6. Efflorescence

6.1 Brick are not required to be tested for efflorescence to comply with this specification unless requested by the specifier or purchaser. When the efflorescence test is requested by the specifier or purchaser, the brick shall be sampled at the place of manufacture, and tested in accordance with Test Methods C 67, and a rating for efflorescence shall be “not effloresced.” If the rating for efflorescence is “effloresced,” the brick represented by the testing do not meet the efflorescence requirements of this specification.

## 7. Dimensions and Permissible Variations

7.1 *Size*—The size of hollow brick shall be as specified by the purchaser. In a sample of ten hollow brick selected to include the extreme range of color and sizes to be supplied, no hollow brick shall depart from the specified size by more than the individual tolerance for the type specified as prescribed in Table 3. Tolerances on dimensions for Type HBA shall be as specified by the purchaser, but not more restrictive than HBS and HBB.

NOTE 3—For a list of modular sizes see Guide E 835/E 835M. Sizes listed in this standard are not produced in all parts of the United States. Brick names denoting sizes may be regional and therefore may not be included in all reference books. Purchasers should ascertain the size of brick available in their locality and should specify accordingly, stating the desired dimensions (width by height by length).

7.2 *Warpage*—Tolerances for distortion or warpage of surfaces or edges intended to be exposed in use of individual hollow brick from a plane surface and from a straight line, respectively, shall not exceed the maximum for the type specified as prescribed in Table 4. Tolerances on distortion for Type HBA shall be as specified by the purchaser.

## 8. Workmanship, Finish, and Appearance

8.1 The face or faces that will be exposed in place shall be free of chips that exceed the limits of Table 5. The limits apply to the types as specified. The aggregate length of chips shall not exceed 10 % of the perimeter of the exposed face or faces of the hollow brick.

8.2 *Other than Chips*—The face or faces shall be free of other imperfections detracting from the appearance of a sample wall when viewed from a distance of 15 ft (4.6 m) for Type HBX and a distance of 20 ft (6.1 m) for Types HBS and HBA.

NOTE 4—Of all the units that will be exposed in place, a small percentage of the units may have chips that are larger in size than those chips allowed for the majority of the units. This special allowed percentage, listed in the second column from the left of Table 5, ranges up to 5 % for HBX, up to 10 %

**TABLE 3 Tolerances on Dimensions, in. (mm)**

Specified Dimensions	Permissible Variation, max	
	Type HBX	Type HBS and HBB
3 (76) and under	± $\frac{1}{16}$ (1.58)	± $\frac{3}{32}$ (2.38)
Over 3 to 4 (102), incl	± $\frac{3}{32}$ (2.38)	± $\frac{1}{8}$ (3.18)
Over 4 to 6 (152), incl	± $\frac{1}{8}$ (3.18)	± $\frac{3}{16}$ (4.76)
Over 6 to 8 (204), incl	± $\frac{5}{32}$ (3.97)	± $\frac{1}{4}$ (6.35)
Over 8 to 12 (306), incl	± $\frac{7}{32}$ (5.56)	± $\frac{5}{16}$ (7.94)
Over 12 to 16 (408), incl	± $\frac{9}{32}$ (7.14)	± $\frac{3}{8}$ (9.52)

**TABLE 4 Tolerances on Distortion, in. (mm)**

Dimension, max	Permissible Distortion, max	
	Type HBX	Type HBS
8 (204) and under	1/16 (1.58)	3/32 (2.38)
Over 8 to 12, (306), incl	3/32 (2.38)	1/8 (3.18)
Over 12 to 16 (408), incl	1/8 (3.18)	5/32 (3.97)

**TABLE 5 Maximum Permissible Range of Chippage That Extends from the Edges and Corners of the Finished Face or Faces Onto the Surface**

Type	Percentage Allowed <sup>A</sup>	Chippage in in. (mm) in from		Percentage Allowed <sup>A</sup>	Chippage in in. (mm) in from	
		Edge	Corner		Edge	Corner
HBX	5 % or less	1/8 to 1/4 (3.18 to 6.35)	1/4 to 3/8 (6.35 to 9.52)	95 to 100 %	0 to 1/8 (0 to 3.18)	0 to 1/4 (0 to 6.35)
HBS (formed) <sup>B</sup>	10 % or less	1/4 to 5/16 (6.35 to 7.94)	3/8 to 1/2 (9.52 to 12.7)	90 to 100 %	0 to 1/4 (0 to 6.35)	0 to 3/8 (0 to 9.52)
HBS (altered) <sup>C</sup>	15 % or less	5/16 to 7/16 (7.94 to 11.11)	1/2 to 3/4 (12.7 to 19.05)	85 to 100 %	0 to 5/16 (0 to 7.94)	0 to 1/2 (0 to 12.7)
HBA and HBB	to meet the designated sample or as specified by the purchaser, but not more restrictive than HBS (altered)					

<sup>A</sup> The allowable percentage of brick that will be exposed in the wall having the allowed maximum size chips measured the listed maximum dimensions in from an edge or corner.

<sup>B</sup> Formed units are extruded brick with an unbroken natural die finish face.

<sup>C</sup> Altered units are extruded brick with the face sanded, combed, scratched, scarified, or broken by mechanical means such as wire-cutting or wire brushing, or are molded brick.

for HBS (formed), and up to 15 % for HBS (altered). The remainder of the units that will be exposed in place, listed in the fifth column from the left, must conform to the chip sizes listed in the sixth and seventh columns from the left.

*Example*—Type HBS (formed) units will conform to the requirements of Table 5 if not more than 10 % of the units have edge chips greater than 1/4 in. (6.4 mm) but less than 5/16 in. (7.9 mm), or corner chips greater than 3/8 in. (9.5 mm) but less than 1/2 in. (12.7 mm) and the remainder of the units, in this maximum case 90 % (100 % – 10 %), do not have edge chips greater than 1/4 in. (6.4 mm) in from the edge nor corner chips greater than 3/8 in. (9.5 mm) in from the corner.

8.3 The brick shall be free of defects, deficiencies, and surface treatments, including coatings, that interfere with the proper setting of the brick or significantly impair the strength or performance of the construction.

8.4 ~~Unless otherwise agreed upon by the purchaser and the seller, a delivery~~

8.4 ~~The number of hollow brick may contain not more than 5 % brick, including broken brick, in a delivery that are broken or otherwise fail to meet the requirements for chippage and tolerances shall not exceed 5 %.~~

8.5 After brick are placed in usage the manufacturer or the manufacturer's agent shall not be held responsible for compliance of brick with the requirements of this specification for chippage and dimensional tolerances.

## 9. Texture and Color

9.1 If brick having a particular color, color range, or texture are desired, these features shall be specified separately by the purchaser. ~~Unless otherwise specified by the purchaser, at~~ At least one end of the majority of the individual hollow brick shall have the same general texture and general color tone as the approved sample. The texture of the finished surfaces that will be exposed when in place shall conform to an approved sample consisting of not less than four stretcher hollow brick, each representing the texture desired. The color range shall be indicated by the approved sample.

9.2 Where brick with other than one finished face and one finished end are required (brick with two finished faces or ends, or other types), all such special brick shall be explicitly specified by the purchaser.

NOTE 5—The manufacturer should be consulted for the availability of specialty units suitable for the intended purpose.

## 10. Hollow Spaces

10.1 *Cores*—The distance of any core (void space having a gross cross-sectional area equal to or less than 1 1/2 in.<sup>2</sup> (9.68 cm<sup>2</sup>)) from exposed edges shall be not less than 5/8 in. (16 mm), except for cored-shell hollow brick.

10.1.1 Cored-shell hollow brick shall have a minimum shell thickness of 1 1/2 in. Cores greater than 1 in.<sup>2</sup> (6.45 cm<sup>2</sup>) in cored shells shall be not less than 1/2 in. (13 mm) from any edge. Cores not greater than 1 in.<sup>2</sup> in shells cored not more than 35 %, shall be not less than 3/8 in. (10 mm) from any edge.

10.2 *Cells*—The distance of cells (void space having a gross cross-sectional area greater than 1 1/2 in.<sup>2</sup>) from any exposed edge of the unit shall not be less than 3/4 in. (19 mm), except for double-shell hollow brick.

10.2.1 Double-shell hollow brick with inner and outer shells not less than 1/2 in. (13 mm) are permitted to have cells not greater than 5/8 in. (16 mm) in width nor 5 in. (127 mm) in length between the inner and outer shell.

10.3 *Webs*—The thickness of webs between cells shall not be less than 1/2 in. (13 mm), 3/8 in. (9.5 mm) between cells and cores, or 1/4 in. (6 mm) between cores.

10.4 *Unexposed Edges*— The distance of voids from unexposed edges, which are recessed not less than 1/2 in. (13 mm), shall be not less than 1/2 in.

~~10.5 Frogging—Unless otherwise specified in the invitation for bids, one~~ One bearing face of each brick ~~is~~ shall be permitted to have a recess or panel frog and deep frogs. The recess or panel frog shall not exceed  $\frac{3}{8}$  in. (9.5 mm) in depth and no part of the recess or panel frog shall be less than  $\frac{5}{8}$  in. (15.9 mm) from any edge of the brick. In brick containing deep frogs, frogs deeper than  $\frac{3}{8}$  in. (9.5 mm), any cross-section through the deep frogs parallel to the bearing surface shall conform to other requirements of this specification for hollow spaces and void area.

## 11. Sampling and Testing

~~11.1 For purposes of tests,~~

~~11.1 The brick that are representative of the commercial product shall be selected by a competent person appointed by the purchaser, the place or places of selection to be designated when the purchase order is placed. The sample or samples shall include specimens representative of the complete range of colors sampled and sizes of the brick supplied or to be supplied. The manufacturer or the seller shall furnish specimens for test without charge.~~

~~11.2 Sample and test the brick tested in accordance with Test Methods C 67.~~

NOTE 6—Unless otherwise specified in the purchase order, the cost of tests is typically borne as follows: If the results of the tests show that the brick do not conform to the requirements of this specification, the cost is typically borne by the seller. If the results of the tests show that the brick do conform to the requirements of this specification, the cost is typically borne by the purchaser.

~~11.2 The manufacturer or the seller shall furnish specimens for test without charge. The place or places of selection shall be designated when the purchase order is placed.~~

## 12. Keywords

12.1 appearance requirements; clay; fired masonry unit; hollow brick; hollow building brick; hollow facing brick; masonry construction; physical properties; shale

## SUMMARY OF CHANGES

Committee C15 has identified the location of selected changes to this standard since C 652–01a that may impact the use of this standard.

- (1) Paragraph 5.1 was changed to remove Grade SW accepted instead of Grade MW.
- (2) Open-ended agreements were removed from 8.4, 9.1, and 10.5.

Committee C15 has identified the location of selected changes to this standard since C 652–01 that may impact the use of this standard.

- (1) Table 5 row titles for HBS brick were revised, and footnotes B and C were modified for clarity and consistency.
- (2) Note 4 was changed to reflect the changes in row titles.

*ASTM International takes no position respecting the validity of any patent rights asserted in connection with any item mentioned in this standard. Users of this standard are expressly advised that determination of the validity of any such patent rights, and the risk of infringement of such rights, are entirely their own responsibility.*

*This standard is subject to revision at any time by the responsible technical committee and must be reviewed every five years and if not revised, either reapproved or withdrawn. Your comments are invited either for revision of this standard or for additional standards and should be addressed to ASTM International Headquarters. Your comments will receive careful consideration at a meeting of the responsible technical committee, which you may attend. If you feel that your comments have not received a fair hearing you should make your views known to the ASTM Committee on Standards, at the address shown below.*

*This standard is copyrighted by ASTM International, 100 Barr Harbor Drive, PO Box C700, West Conshohocken, PA 19428-2959, United States. Individual reprints (single or multiple copies) of this standard may be obtained by contacting ASTM at the above address or at 610-832-9585 (phone), 610-832-9555 (fax), or service@astm.org (e-mail); or through the ASTM website (www.astm.org).*