



**Designation: C 654 – 9903**

## **Standard Specification for Porous Concrete Pipe<sup>1</sup>**

This standard is issued under the fixed designation C 654; the number immediately following the designation indicates the year of original adoption or, in the case of revision, the year of last revision. A number in parentheses indicates the year of last reapproval. A superscript epsilon ( $\epsilon$ ) indicates an editorial change since the last revision or reapproval.

*This standard has been approved for use by agencies of the Department of Defense.*

### **1. Scope**

1.1 This specification covers porous nonreinforced concrete pipe for use in underdrains.

1.2 A complete metric companion to this specification has been developed— 654M; therefore, no metric equivalents are presented in this specification.

### **2. Referenced Documents**

2.1 *ASTM Standards:*

C 33 Specification for Concrete Aggregates<sup>2</sup>

---

<sup>1</sup> This specification is under the jurisdiction of ASTM Committee C-13 on Concrete Pipe and is the direct responsibility of Subcommittee C13.01 on Reinforced Concrete Sewer, Drain, and Irrigation Pipe.

Current edition approved ~~Aug. 10, 1999~~, 2003. Published September 1999, 2003. Originally published as C 654-70F, approved in 1970. Last previous edition ~~C 654-95<sup>1</sup>~~, approved in 1999 as C 654 – 99.

C 150 Specification for Portland Cement<sup>3</sup>

C 497 Test Methods for Concrete Pipe, Manhole Sections, or Tile<sup>4</sup>

C 595 Specification for Blended Hydraulic Cements<sup>3</sup>

C 618 Specification for Coal Fly Ash and Raw or Calcined Natural Pozzolan for Use as a Mineral Admixture in Concrete<sup>2</sup>

C 822 Terminology Relating to Concrete Pipe and Related Products<sup>4</sup>

C 1116 Specification for Fiber-Reinforced Concrete and Shotcrete<sup>2</sup>

### 3. Terminology

3.1 *Definitions*—For definitions of terms relating to concrete pipe, see Terminology C 822.

### 4. Classification

4.1 Pipe manufactured according to this specification shall be of two classes identified as “Standard-Strength Porous Nonreinforced Concrete Pipe” and “Extra-Strength Porous Nonreinforced Concrete Pipe.”

### 5. Basis of Acceptance

5.1 The acceptability of the pipe shall be determined by the results of the strength and porosity or rate of infiltration tests, and by inspection to determine whether the pipe conforms to this specification as to design and freedom from defects.

5.2 The pipe shall be acceptable under the strength tests when they have met the requirements as prescribed in Section 10.

5.3 *Acceptance as to Infiltration Properties*—Pipe shall be acceptable under the infiltration test when all test pipe conform to the test requirements as prescribed in Section 10.

### 6. Materials

6.1 *Concrete*—The concrete shall consist of cementitious materials and water.

6.2 *Cementitious Materials*:

6.2.1 *Cement*—Cement shall conform to the requirements for portland cement of Specification C 150 or shall be portland blast-furnace slag cement or portland-pozzolan cement conforming to the requirements of Specification C 595, except that the pozzolan constituent in the Type IP portland-pozzolan cement shall be fly ash.

6.2.2 *Fly Ash*—Fly ash shall conform to the requirements of Specification C 618, Class F or Class C.

6.2.3 *Allowable Combinations of Cementitious Materials*—The combination of cementitious materials used in the concrete shall be one of the following:

6.2.3.1 Portland cement only,

6.2.3.2 Portland blast furnace slag cement only,

6.2.3.3 Portland pozzolan cement only, or

6.2.3.4 A combination of portland cement and fly ash.

NOTE 1—The user of this specification is advised that porous pipe may experience leaching detrimental to durability when subjected to drainage of soft or acid waters (less than 50 ppm hardness or less than 6.0 pH). Type V portland cement should be specified where high sulfate resistance is required, and Type II or IIA portland cement should be specified where the pipe will be exposed to moderate sulfate conditions. More than 3000 ppm of chiefly sodium or magnesium sulfates, or both, may be considered high sulfate content.

6.3 *Aggregates*—Aggregates shall conform to Specification C 33 except that the requirement for gradation shall not apply.

6.4 *Admixtures and Blends*—Admixtures and blends ~~may~~ shall only be used with the approval of the owner.

6.5 *Synthetic Fibers*—Collated fibrillated virgin polypropylene fibers ~~may be used, at the manufacturer’s option, are not prohibited~~ in concrete pipe as a nonstructural manufacturing material. Only Type III synthetic fibers designed and manufactured specifically for use in concrete and conforming to the requirements of Specification C 1116 shall be accepted.

### 7. Design

7.1 *Design Tables*—Design requirements shall be in accordance with Table 1 and Table 2 and Fig. 1. Wall thickness used ~~may shall be more than but~~ not less than the value shown, except as affected by the tolerance herein specified.

### 8. Joints

8.1 The joints shall be of such design and the ends of the concrete pipe sections so formed that the pipe can be laid together to make a continuous line of pipe compatible with the permissible variations given in Section 7.

### 9. Manufacture

9.1 *Mixture*—The aggregates shall be sized, graded, proportioned, and mixed with such proportions of cementitious materials and water as will produce a homogeneous concrete mixture of such quality that the pipe will conform to the test and design requirements of this specification.

<sup>2</sup> Annual Book of ASTM Standards, Vol 04.02.

<sup>3</sup> Annual Book of ASTM Standards, Vol 04.01.

<sup>4</sup> Annual Book of ASTM Standards, Vol 04.05.

**TABLE 1 Physical and Dimensional Requirements of Porous Concrete Pipe**

Internal Designated Diameter, <i>D</i>	Minimum <sup>A</sup> Wall Thickness, <i>T</i>	Minimum Laying Length <sup>A</sup>	Minimum Socket Depth, <i>L<sub>s</sub></i>	Minimum Strength Three-Edge-Bearing	Minimum Infiltration
in.	in.	in.	in.	lb/ft	gal/min-ft
4	1	24	1	1000	4
6	1	24	1	1100	6
8	1¼	24	1¼	1300	8
10	1½	24	1½	1400	10
12	1½	24	1½	1500	12
15	1¾	24	1¾	1750	15
18	2	24	2	2000	18
21	2¼	24	2¼	2200	21
24	2½	24	2½	2400	24

<sup>A</sup> Normally the minimum laying length is 24 in. in length, but if the owner has no objections, then 18-in. length pipe up to 12 in. in diameter may be accepted.

**TABLE 2 Physical and Dimensional Requirements of Extra-Strength Porous Concrete Pipe**

Internal Designated Diameter, <i>D</i>	Minimum Wall Thickness, <i>T</i>	Minimum Laying Length <sup>A</sup>	Minimum Socket Depth, <i>L<sub>s</sub></i>	Minimum Strength Three-Edge-Bearing	Minimum Infiltration
in.	in.	in.	in.	lb/ft	gal/min-ft
8	1½	24	1½	2600	8
10	1⅝	24	1⅝	2800	10
12	2	24	2	3000	12
15	2¼	24	2¼	3200	15
18	2½	24	2½	3200	18

<sup>A</sup> Normally the minimum laying length is 24 in. in length, but if the owner has no objections, then 18-in. length pipe up to 12 in. in diameter may be accepted.

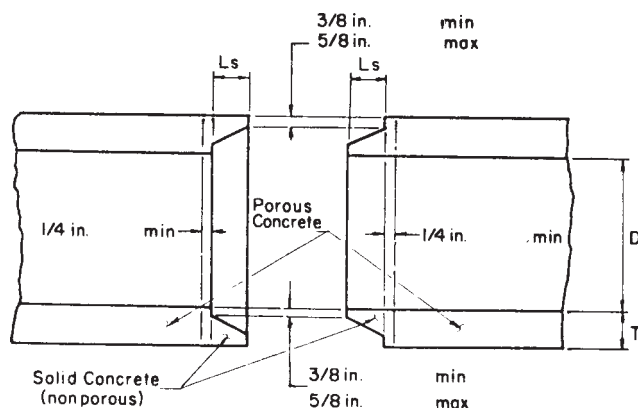

Note—See Table 1 and Table 2 for values of *D*, *T*, and *L<sub>s</sub>*.

**FIG. 1 Joint Dimensions**

9.2 *Curing*—Pipe shall be subjected to any one of the methods of curing described in 9.2.1 through 9.2.3, or to any other method or combination of methods approved by the owner that will give satisfactory results. The pipe shall be cured for a sufficient length of time so that the concrete will develop the specified strength requirement at 28 days or less.

9.2.1 *Steam Curing*— Pipe ~~may~~ shall be placed in a curing chamber, free from outside drafts, and cured in a moist atmosphere maintained by the injection of steam for such time and at such temperature as ~~may be~~ needed to enable the pipe to meet the strength requirements. The curing chamber shall be constructed as to allow full circulation of steam around the entire pipe.

9.2.2 *Water Curing*— Concrete pipe ~~may~~ shall be water-cured by covering with water-saturated material or by a system of perforated pipes, mechanical sprinklers, porous hose, or by any other approved method that will keep the pipe moist during the specified curing period.

9.2.3 The manufacturer ~~may, at his option,~~ has the option to combine the methods described in 9.2.1 and 9.2.2 provided the specified strength is attained.

9.3 *Specials:*

9.3.1 *General Requirements*—Special shapes or fittings such as wyes, tees, bends, and adapters for use with concrete pipe conforming to this specification shall be made of porous or nonporous concrete in such manner as will provide strength at least equal to the class of the adjacent pipe to which they are joined; and shall conform to all other requirements specified for pipe of corresponding class and internal diameter, except minimum infiltration. Joints shall be the same type as used in the adjoining pipe.

9.3.2 *Wyes and Tees*— Fabricated branches for wyes and tees shall be securely attached to the wall of the pipe and shall be flush with the inside surface of the pipe.

## 10. Physical Requirements

10.1 *Test Specimen*— The specified number of pipe required for the test shall be furnished by the manufacturer and shall be selected at random by the owner, and shall be pipe that would not otherwise be rejected under this specification. The selection shall be made at the point or points designated by the owner when placing the order. The test pipe shall first be freed from all visible moisture. When dry, each pipe shall be measured and inspected. The results of these observations shall be recorded.

10.2 *Number and Type of Test Specimens* —The manufacturer shall furnish pipe for crushing tests, up to 0.5 % of the number of pipe of each size included in the order, except that in no case shall less than two pipes be furnished.

10.3 *External Load Crushing Requirements* —The crushing strength of porous nonreinforced concrete pipe shall conform to the requirements prescribed in Table 1 and Table 2. The individual results of the various tests for each size of pipe and for each shipment and plant shall be tabulated separately. The crushing strength shall ordinarily be applied to not less than 75 % of the pipe received for purpose of test. All tests shall be made in accordance with Test Methods C 497. Pipe shall be acceptable when all test pipe conform to the specified strength requirement. Should any of the test pipe provided in 10.2 fail to meet the strength requirement, the manufacturer will be allowed to test two pipe for each pipe that failed, and the pipe shall be acceptable only when all of these additional test pipe meet the strength requirement.

10.4 *Infiltration Requirement*—Infiltration (or porosity) shall conform to the requirements in Table 1 or Table 2.

10.4.1 The test pipe shall be placed with a spigot end down on a soft rubber nonpermeable mat, or its equivalent, and weighted or clamped down if necessary to prevent the escape of water through the spigot end of the pipe.

10.4.2 Water shall be introduced into the pipe, and the distance above the bottom of the porous section at which the water level becomes constant shall be determined. The rate of flow shall be at least equal to the required minimum infiltration for 1 ft of pipe as given in Table 1 or Table 2.

10.4.3 The rate of infiltration per foot of pipe shall be determined as follows:

$$GPM = g/h$$

where:

*GPM* = infiltration rate in gallons per minute per foot of pipe,

*g* = gallons per minute of flow introduced into the test pipe, and

*h* = height in feet from the bottom of the porous section of the pipe at which the level of water becomes constant.

10.5 *Test Equipment*— The manufacturer shall furnish all equipment, facilities, and personnel necessary to perform at his plant the tests specified in Section 10. In the event that the owner elects to have tests performed at any other location, the manufacturer will not be required to furnish equipment, facilities, nor personnel.

## 11. Permissible Variations

11.1 *Size and Dimensions*—Pipe shall be furnished in the sizes, internal diameters, and dimensions prescribed in Table 1, Table 2, and Table 3 and Fig. 1.

11.2 Permissible variations from the dimensions described in Table 1 and Table 2 shall not exceed those stated in Table 3. This is not to be construed, however, that heavier wall thickness pipe cannot be furnished at the option of the manufacturer. Pipe intended to be straight shall not have variation in alignment of more than 1/8 in./ft of length.

## 12. Repairs

12.1 Pipe ~~may be repaired, if necessary,~~ repaired because of imperfections in manufacture or damage during handling and will be acceptable, if in the opinion of the owner, and the repaired pipe conforms to the requirements of this specification.

## 13. Inspection

13.1 The quality of all materials, in the process of manufacture, and the finished pipe shall be subject to the inspection and approval by the owner. Such inspection ~~may~~ shall be performed either at the point of manufacture or delivery.

**TABLE 3 Permissible Variations in Dimensions of Porous Concrete Pipe**

Limits of Permissible Variation					
Internal Designated Diameter,	Internal Diameter, <sup>A</sup>	Length, Two Opposite Sides	Wall Thickness, <sup>A</sup> c	Length,	Depth of Socket, <sup>A</sup>
in.	in.	in.	in.	in./ft	in.
4	±1/8	-1/16	1/4	-1/4	-1/8
6	±1/8	-1/16	1/4	-1/4	-1/8
8	±1/4	-1/16	5/16	-1/4	-1/4
10	±1/4	-1/16	3/8	-1/4	-1/4
12	±1/4	-1/16	3/8	-1/4	-1/4
15	±1/4	-3/32	7/16	-1/4	-1/4
18	±1/4	-3/32	1/2	-1/4	-1/4
21	±1/4	-1/8	9/16	-1/4	-1/4
24	±1/4	-1/8	9/16	-3/8	-1/4

<sup>A</sup> The minus sign (-) indicates that the plus variation is not limited; the plus and minus (±) indicates variation in both excess and deficiency in dimension.

## 14. Rejection

14.1 Pipe shall be subject to rejection on account of failure to conform to any of the specification requirements. It is not prohibited for individual sections of pipe may to be rejected because of any of the following:

14.1.1 Fractures or cracks passing through the wall or joints, except that a single crack not exceeding 2 in. in length at either end of a pipe or a single fracture in the joints not exceeding 3 in. in width nor more than 2 in. in length shall not be considered cause for rejection unless these defects exist in more than 5 % of the entire shipment or delivery.

14.1.2 The planes of the ends of the pipe are not perpendicular to the longitudinal axis, subject to the limits of variation as shown in Table 3.

14.1.3 Defects that indicate mixing and molding not in accordance with 9.1.

14.1.4 Cracks sufficient to impair the strength, durability, or serviceability of the pipe.

## 15. Marking

15.1 The letters “ES” shall be legibly stamped with waterproof ink, or other permanent matter, on all extra-strength porous concrete pipe.

## 16. Keywords

16.1 concrete pipe; nonreinforced; porous; underdrains

*ASTM International takes no position respecting the validity of any patent rights asserted in connection with any item mentioned in this standard. Users of this standard are expressly advised that determination of the validity of any such patent rights, and the risk of infringement of such rights, are entirely their own responsibility.*

*This standard is subject to revision at any time by the responsible technical committee and must be reviewed every five years and if not revised, either reapproved or withdrawn. Your comments are invited either for revision of this standard or for additional standards and should be addressed to ASTM International Headquarters. Your comments will receive careful consideration at a meeting of the responsible technical committee, which you may attend. If you feel that your comments have not received a fair hearing you should make your views known to the ASTM Committee on Standards, at the address shown below.*

*This standard is copyrighted by ASTM International, 100 Barr Harbor Drive, PO Box C700, West Conshohocken, PA 19428-2959, United States. Individual reprints (single or multiple copies) of this standard may be obtained by contacting ASTM at the above address or at 610-832-9585 (phone), 610-832-9555 (fax), or service@astm.org (e-mail); or through the ASTM website (www.astm.org).*