



Standard Test Methods for Sampling and Testing Brick and Structural Clay Tile¹

This standard is issued under the fixed designation C 67; the number immediately following the designation indicates the year of original adoption or, in the case of revision, the year of last revision. A number in parentheses indicates the year of last reapproval. A superscript epsilon (ϵ) indicates an editorial change since the last revision or reapproval.

This standard has been approved for use by agencies of the Department of Defense.

1. Scope*

1.1 These test methods cover procedures for the sampling and testing of brick and structural clay tile. Although not necessarily applicable to all types of units, tests include modulus of rupture, compressive strength, absorption, saturation coefficient, effect of freezing and thawing, efflorescence, initial rate of absorption and determination of weight, size, warpage, length change, and void area. (Additional methods of test pertinent to ceramic glazed facing tile are included in Specification C 126.)

1.2 The text of this standard references notes and footnotes which provide explanatory material. These notes and footnotes (excluding those in tables and figures) shall not be considered as requirements of the standard.

NOTE 1—The testing laboratory performing this test method should be evaluated in accordance with Practice C 1093.

1.3 Unless otherwise indicated, the values stated in inch-pound units are to be regarded as the standard. The values given in parentheses are for information only.

1.4 *This standard does not purport to address all of the safety concerns, if any, associated with its use. It is the responsibility of the user of this standard to establish appropriate safety and health practices and determine the applicability of regulatory limitations prior to use.*

2. Referenced Documents

2.1 ASTM Standards:

- C 43 Terminology of Structural Clay Products²
- C 126 Specification for Ceramic Glazed Structural Clay Facing Tile, Facing Brick, and Solid Masonry Units²
- C 150 Specification for Portland Cement³
- C 1093 Practice for Accreditation of Testing Agencies for Unit Masonry²

¹ These test methods are under the jurisdiction of Committee C15 on Manufactured Masonry Units and is the direct responsibility of Subcommittee C15.02 on Brick and Structural Clay Tile.

Current edition approved January 10, 2003. Published August 2003. Originally published as C 67 – 37T and C 112 – 34T. Last previous edition approved in 2002 as C 67 – 02c.

² *Annual Book of ASTM Standards*, Vol 04.05.

³ *Annual Book of ASTM Standards*, Vol 04.01.

E 4 Practices for Force Verification of Testing Machines⁴

E 6 Terminology Relating to Methods of Mechanical Testing⁴

3. Terminology

3.1 *Definitions*—Terminology E 6 and Terminology C 43 shall be considered as applying to the terms used in these test methods.

4. Sampling

4.1 *Selection of Test Specimens*—For the purpose of these tests, whole full-size brick or tile units shall be selected by the purchaser or by the purchaser's authorized representative. Specimens shall be representative of the lot of units from which they are selected and shall include specimens representative of the complete range of colors, textures, and sizes and shall be free of dirt, mud, mortar, or other foreign materials unassociated with the manufacturing process.

4.2 Number of Specimens:

4.2.1 *Brick*—For the modulus of rupture, compressive strength, abrasion resistance, and absorption determinations, at least ten individual brick shall be selected for lots of 1 000 000 brick or fraction thereof. For larger lots, five additional specimens shall be selected from each additional 500 000 brick or fraction thereof. Additional specimens are taken at the discretion of the purchaser.

4.2.2 *Structural Clay Tile*—For the weight determination and for compressive strength and absorption tests, at least five tile shall be selected from each lot of 250 tons (226.8 Mg) or fraction thereof. For larger lots, five additional specimens shall be tested for each 500 tons (453.6 Mg) or fraction thereof. In no case shall less than five tile be taken. Additional specimens are taken at the discretion of the purchaser.

4.3 *Identification*—Each specimen shall be marked so that it may be identified at any time. Markings shall cover not more than 5 % of the superficial area of the specimen.

5. Specimen Preparation

5.1 Weight Determination:

5.1.1 *Drying*—Dry the test specimens in a ventilated oven at 230 to 239°F (110 to 115°C) for not less than 24 h and until

⁴ *Annual Book of ASTM Standards*, Vol 03.01.

***A Summary of Changes section appears at the end of this standard.**

two successive weighings at intervals of 2 h show an increment of loss not greater than 0.2 % of the last previously determined weight of the specimen.

5.1.2 *Cooling*—After drying, cool the specimens in a drying room maintained at a temperature of $75 \pm 15^\circ\text{F}$ ($24 \pm 8^\circ\text{C}$), with a relative humidity between 30 and 70 %. Store the units free from drafts, unstacked, with separate placement, for a period of at least 4 h and until the surface temperature is within 5°F (2.8°C) of the drying room temperature. Do not use specimens noticeably warm to the touch for any test requiring dry units. The specimens shall be stored in the drying room with the required temperature and humidity maintained until tested.

5.1.2.1 An alternative method of cooling the specimens to approximate room temperature shall be permitted as follows: Store units, unstacked, with separate placement, in a ventilated room maintained at a temperature of $75 \pm 15^\circ\text{F}$ ($24 \pm 8^\circ\text{C}$), with a relative humidity between 30 and 70 % for a period of 4 h and until the surface temperature is within 5°F (2.8°C) of the ventilated room temperature, with a current of air from an electric fan passing over them for a period of at least 2 h. The specimens shall be stored in the ventilated room with the required temperature and humidity maintained until tested.

5.1.3 *Weighing and Report:*

5.1.3.1 Weigh five dry full size specimens. The scale or balance used shall have a capacity of not less than 3000 g and shall be sensitive to 0.5 g.

5.1.3.2 Report results separately for each specimen to the nearest 0.1 g, with the average of all specimens tested to the nearest 0.1 g.

5.2 *Removal of Silicone Coatings from Brick Units*—The silicone coatings intended to be removed by this process are any of the various polymeric organic silicone compounds used for water-resistant coatings of brick units. Heat the brick at $950 \pm 50^\circ\text{F}$ ($510 \pm 28^\circ\text{C}$) in an oxidizing atmosphere for a period of not less than 3 h. The rate of heating and cooling shall not exceed 300°F (149°C) per h.

NOTE 2—Where indicated for specific individual tests, additional specimen preparation may be required.

6. Modulus of Rupture (Flexure Test)

6.1 *Test Specimens*—The test specimens shall consist of whole dry full-size units (see 5.1.1). Five such specimens shall be tested.

6.2 *Procedure:*

6.2.1 Support the test specimen flatwise unless specified and reported otherwise (that is, apply the load in the direction of the depth of the unit) on a span approximately 1 in. (25.4 mm) less than the basic unit length and loaded at midspan. If the specimens have recesses (panels or depressions) place them so that such recesses are on the compression side. Apply the load to the upper surface of the specimen through a steel bearing plate $\frac{1}{4}$ in. (6.35 mm) in thickness and $1\frac{1}{2}$ in. (38.10 mm) in width and of a length at least equal to the width of the specimen.

6.2.2 Make sure the supports for the test specimen are free to rotate in the longitudinal and transverse directions of the test specimen and adjust them so that they will exert no force in these directions.

6.2.3 *Speed of Testing*—The rate of loading shall not exceed 2000 lbf (8896 N)/min. but this requirement is considered as being met if the speed of the moving head of the testing machine immediately prior to application of the load is not more than 0.05 in. (1.27 mm)/min.

6.3 *Calculation and Report:*

6.3.1 Calculate and report the modulus of rupture of each specimen to the nearest 1 psi (0.01 MPa) as follows:

$$S = 3W(l/2 - x) / bd^2 \quad (1)$$

where:

S = modulus of rupture of the specimen at the plane of failure, lb/in.² (Pa),

W = maximum load indicated by the testing machine, lbf (N),

l = distance between the supports, in. (mm),

b = net width, (face to face minus voids), of the specimen at the plane of failure, in. (mm),

d = depth, (bed surface to bed surface), of the specimen at the plane of failure, in. (mm), and

x = average distance from the midspan of the specimen to the plane of failure measured in the direction of the span along the centerline of the bed surface subjected to tension, in. (mm).

6.3.2 Calculate and report the average of the modulus of rupture determinations to the nearest 1 psi (0.01 MPa).

7. Compressive Strength

7.1 *Test Specimens:*

7.1.1 *Brick*—The test specimens shall consist of dry half brick (see 5.1.1), the full height and width of the unit, with a length equal to one half the full length of the unit ± 1 in. (25.4 mm), except as described below. If the test specimen, described above, exceeds the testing machine capacity, the test specimens shall consist of dry pieces of brick, the full height and width of the unit, with a length not less than one quarter of the full length of the unit, and with a gross cross-sectional area perpendicular to bearing not less than 14 in.² (90.3 cm²). Test specimens shall be obtained by any method that will produce, without shattering or cracking, a specimen with approximately plane and parallel ends. Five specimens shall be tested.

7.1.2 *Structural Clay Tile*—Test five dry tile specimens in a bearing bed length equal to the width ± 1 in. (25.4 mm); or test full-size units.

7.2 *Capping Test Specimens:*

7.2.1 All specimens shall be dry and cool within the meaning of 5.1.1 and 5.1.2 before any portion of the capping procedure is carried out.

7.2.2 If the surface which will become bearing surfaces during the compression test are recessed or paneled, fill the depressions with a mortar composed of 1 part by weight of quick-hardening cement conforming to the requirements for Type III cement of Specification C 150, and 2 parts by weight of sand. Age the specimens at least 48 h before capping them. Where the recess exceeds $\frac{1}{2}$ in. (12.7 mm), use a brick or tile

slab section or metal plate as a core fill. Cap the test specimens using one of the two procedures described in 7.2.3 and 7.2.4.

7.2.3 Gypsum Capping—Coat the two opposite bearing surfaces of each specimen with shellac and allow to dry thoroughly. Bed one of the dry shellacked surfaces of the specimen in a thin coat of neat paste of calcined gypsum (plaster of paris) that has been spread on an oiled nonabsorbent plate, such as glass or machined metal. The casting surface plate shall be plane within 0.003 in. (0.076 mm) in 16 in. (406.4 mm) and sufficiently rigid; and so supported that it will not be measurably deflected during the capping operation. Lightly coat it with oil or other suitable material. Repeat this procedure with the other shellacked surface. Take care that the opposite bearing surfaces so formed will be approximately parallel and perpendicular to the vertical axis of the specimen and the thickness of the caps will be approximately the same and not exceeding 1/8 in. (3.18 mm). Age the caps at least 24 h before testing the specimens.

NOTE 3—A rapid-setting industrial type gypsum is frequently used for capping.

7.2.4 Sulfur-Filler Capping—Use a mixture containing 40 to 60 weight % sulfur, the remainder being ground fire clay or other suitable inert material passing a No. 100 (150- μ m) sieve with or without plasticizer. The casting surface plate requirements shall be as described in 7.2.3. Place four 1-in. (25.4-mm) square steel bars on the surface plate to form a rectangular mold approximately 1/2 in. (12.7 mm) greater in either inside dimension than the specimen. Heat the sulfur mixture in a thermostatically controlled heating pot to a temperature sufficient to maintain fluidity for a reasonable period of time after contact with the surface being capped. Take care to prevent overheating, and stir the liquid in the pot just before use. Fill the mold to a depth of 1/4 in. (6.35 mm) with molten sulfur material. Place the surface of the unit to be capped quickly in the liquid, and hold the specimen so that its vertical axis is at right angles to the capping surface. The thickness of the caps shall be approximately the same. Allow the unit to remain undisturbed until solidification is complete. Allow the caps to cool for a minimum of 2 h before testing the specimens.

7.3 Procedure:

7.3.1 Test brick specimens flatwise (that is, the load shall be applied in the direction of the depth of the brick). Test structural clay tile specimens in a position such that the load is applied in the same direction as in service. Center the specimens under the spherical upper bearing within 1/16 in. (1.59 mm).

7.3.2 The testing machine shall conform to the requirements of Practices E 4.

7.3.3 The upper bearing shall be a spherically seated, hardened metal block firmly attached at the center of the upper head of the machine. The center of the sphere shall lie at the center of the surface of the block in contact with the specimen. The block shall be closely held in its spherical seat, but shall be free to turn in any direction, and its perimeter shall have at least 1/4 in. (6.35 mm) clearance from the head to allow for specimens whose bearing surfaces are not exactly parallel. The diameter of the bearing surface shall be at least 5 in. (127.00 mm). Use a hardened metal bearing block beneath the speci-

men to minimize wear of the lower platen of the machine. The bearing block surfaces intended for contact with the specimen shall have a hardness not less than HRC60 (HB 620). These surfaces shall not depart from plane surfaces by more than 0.001 in. (0.03 mm). When the bearing area of the spherical bearing block is not sufficient to cover the area of the specimen, place a steel plate with surfaces machined to true planes within \pm 0.001 in. (0.03 mm), and with a thickness equal to at least one third of the distance from the edge of the spherical bearing to the most distant corner between the spherical bearing block and the capped specimen.

7.3.4 Speed of Testing—Apply the load, up to one half of the expected maximum load, at any convenient rate, after which, adjust the controls of the machine so that the remaining load is applied at a uniform rate in not less than 1 nor more than 2 min.

7.4 Calculation and Report:

7.4.1 Calculate and report the compressive strength of each specimen to the nearest 10 psi (0.01 MPa) as follows:

$$\text{Compressive strength, } C = W / A \quad (2)$$

where:

C = compressive strength of the specimen, lb/in.² (or kg/cm²) (or Pa·10⁴),

W = maximum load, lbf, (or kgf) (or N), indicated by the testing machine, and

A = average of the gross areas of the upper and lower bearing surfaces of the specimen, in.² (or cm²).

NOTE 4—When compressive strength is to be based on net area (example: clay floor tile), substitute for A in the above formula the net area, in in.² (or cm²), of the fired clay in the section of minimum area perpendicular to the direction of the load.

7.4.2 Calculate and report the average of the compressive strength determinations to the nearest 10 psi (0.1 MPa).

8. Absorption

8.1 Accuracy of Weighings:

8.1.1 Brick—The scale or balance used shall have a capacity of not less than 2000 g, and shall be sensitive to 0.5 g.

8.1.2 Tile—The balance used shall be sensitive to within 0.2 % of the weight of the smallest specimen tested.

8.2 Test Specimens:

8.2.1 Brick—The test specimens shall consist of half brick conforming to the requirements of 7.1.1. Five specimens shall be tested.

8.2.2 Tile—The specimens for the absorption test shall consist of five tile or three representative pieces from each of these five tile. If small pieces are used, take two from the shell and one from an interior web, the weight of each piece being not less than 227 g. The specimens shall have had their rough edges or loose particles ground off and, if taken from tile that have been subjected to compressive strength tests, specimens shall be free of cracks due to failure in compression.

8.3 5-h and 24-h Submersion Tests:

8.3.1 Procedure:

8.3.1.1 Dry and cool the test specimens in accordance with 5.1.1 and 5.1.2 and weigh each one.

8.3.1.2 Saturation—Submerge the dry, cooled specimen, without preliminary partial immersion, in clean water (soft, distilled or rain water) at 60 to 86°F (15.5 to 30°C) for the

specified time. Remove the specimen, wipe off the surface water with a damp cloth and weigh the specimen. Complete weighing of each specimen within 5 min after removing the specimen from the bath.

8.3.2 Calculation and Report:

8.3.2.1 Calculate and report the cold water absorption of each specimen to the nearest 0.1 % as follows:

$$\text{Absorption, \%} = 100(W_s - W_d) / W_d \quad (3)$$

where:

W_d = dry weight of the specimen, and

W_s = saturated weight of the specimen after submersion in cold water.

8.3.2.2 Calculate and report the average cold water absorption of all specimens to the nearest 0.1 %.

8.4 1-h, 2-h, and 5-h Boiling Tests:

8.4.1 *Test Specimens*—The test specimens shall be the same five specimens used in the 5-h or 24-h cold-water submersion test where required and shall be used in the state of saturation existing at the completion of that test.

8.4.2 Procedure:

8.4.2.1 Return the specimen that has been subjected to the cold-water submersion to the bath, and subject it to the boiling test as described in 8.4.2.2.

8.4.2.2 Submerge the specimen in clean water (soft, distilled or rain water) at 60 to 86°F (15.5 to 30°C) in such a manner that water circulates freely on all sides of the specimen. Heat the water to boiling, within 1 h, boil continuously for specified time, and then allow to cool to 60 to 86°F (15.5 to 30°C) by natural loss of heat. Remove the specimen, wipe off the surface water with a damp cloth, and weigh the specimen. Complete weighing of each specimen within 5 min after removing the specimen from the bath.

8.4.2.3 If the tank is equipped with a drain so that water at 60 to 86°F (15.5 to 30°C) passes through the tank continuously and at such a rate that a complete change of water takes place in not more than 2 min, make weighings at the end of 1 h.

8.4.3 Calculation and Report:

8.4.3.1 Calculate and report the boiling water absorption of each specimen to the nearest 0.1 % as follows:

$$\text{Absorption, \%} = 100(W_b - W_d) / W_d \quad (4)$$

where:

W_d = dry weight of the specimen, and

W_b = saturated weight of the specimen after submersion in boiling water.

8.4.3.2 Calculate and report the average boiling water absorption of all specimens to the nearest 0.1 %.

8.5 Saturation Coefficient:

8.5.1 Calculate and report the saturation coefficient of each specimen to the nearest 0.01 as follows:

$$\text{Saturation coefficient} = W_s^2 - W_d / W_b^5 - W_d \quad (5)$$

where:

W_d = dry weight of the specimen,

W_s^2 = saturated weight of the specimen after 24-h submersion in cold water, and

W_b^5 = saturated weight of the specimen after 5-h submersion in boiling water.

8.5.2 Calculate and report the average saturation coefficient of all specimens to the nearest 0.01.

9. Freezing and Thawing

9.1 Apparatus:

9.1.1 *Compressor, Freezing Chamber, and Circulator* of such design and capacity that the temperature of the air in the freezing chamber will not exceed 16°F (−9°C) 1 h after introducing the maximum charge of units, initially at a temperature not exceeding 90°F (32°C).

9.1.2 *Trays and Containers*, shallow, metal, having an inside depth of 1½ ± ½ in. (38.1 ± 12.7 mm), and of suitable strength and size so that the tray with a charge of frozen units can be removed from the freezing chamber by one man.

9.1.3 *Balance*, having a capacity of not less than 2000 g and sensitive to 0.5 g.

9.1.4 *Drying Oven* that provides a free circulation of air through the oven and is capable of maintaining a temperature between 230 and 239°F (110 and 115°C).

9.1.5 *Thawing Tank* of such dimensions as to permit complete submersion of the specimens in their trays. Adequate means shall be provided so that the water in the tank may be kept at a temperature of 75 ± 10°F (24 ± 5.5°C).

9.1.6 *Drying Room*, maintained at a temperature of 75 ± 15°F (24 ± 8°C), with a relative humidity between 30 and 70 %, and free from drafts.

9.2 Test Specimens:

9.2.1 *Brick*—The test specimens shall consist of half brick with approximately plane and parallel ends. If necessary, the rough ends may be smoothed by trimming off a thin section with a masonry saw. The specimens shall be free from shattering or unsoundness, visually observed, resulting from the flexure or from the absorption tests. Additionally, prepare specimens by removing all loosely adhering particles, sand or edge shards from the surface or cores. Test five specimens.

9.2.2 *Structural Clay Tile*—The test specimens shall consist of five tile or of a cell not less than 4 in. (101.6 mm) in length sawed from each of the five tile.

9.3 Procedure:

9.3.1 Dry and cool the test specimens as prescribed in 5.1.1 and 5.1.2 and weigh and record the dry weight of each.

9.3.2 Carefully examine each specimen for cracks. A crack is defined as a fissure or separation visible to a person with normal vision from a distance of one foot under an illumination of not less than 50 fc. Mark each crack its full length with an indelible felt marking pen.

9.3.3 Submerge the test specimens in the water of the thawing tank for 4 ± ½ h.

9.3.4 Remove the specimens from the thawing tank and stand them in the freezing trays with one of their head faces down. Head face is defined as the end surfaces of a whole rectangular brick (which have the smallest area). A space of at least ½ in. (12.7 mm) shall separate the specimens as placed in the tray. Pour sufficient water into the trays so that each specimen stands in ½ in. depth of water and then place the trays and their contents in the freezing chamber for 20 ± 1 h.

9.3.5 Remove the trays from the freezing chamber after 20 ± 1 h and totally immerse them and their contents in the water of the thawing tank for $4 \pm \frac{1}{2}$ h.

9.3.6 Freeze the test specimens by the procedure in 9.3.4 one cycle each day of the normal work week. Following the $4 \pm \frac{1}{2}$ h thawing after the last freeze-thaw cycle of the normal work week, remove the specimens from the trays and store them for 44 ± 1 h in the drying room. Do not stack or pile units. Provide a space of at least 1 in. (25.4 mm) between all specimens. Following this period of air drying, inspect the specimens, submerge them in the water of the thawing tank for $4 \pm \frac{1}{2}$ h, and again subject them to a normal week of freezing and thawing cycles in accordance with 9.3.4 and 9.3.5. When a normal 5-day work week is interrupted, put specimens into a drying cycle which may extend past the 44 ± 1 h drying time outlined in the procedures of this section.

9.3.7 Continue the alternations of drying and submersion in water for $4 \pm \frac{1}{2}$ h, followed by 5 cycles of freezing and thawing or the number of cycles needed to complete a normal work week, until a total of 50 cycles of freezing and thawing has been completed. Stop the test if the test specimen develops a crack as defined in 9.4.3, breaks, or appears to have lost more than 3 % of its original weight by disintegration as judged by visual inspection.

9.3.8 After completion of 50 cycles, or when the test specimen has been withdrawn from test as a result of disintegration, dry and weigh the specimen as prescribed in 9.3.1.

9.4 Calculations, Examination, Rating and Report:

9.4.1 *Calculation*—Calculate the loss in weight as a percentage of the original weight of the dried specimen.

9.4.2 *Examination*—Re-examine the surface of the specimens for cracks (see 9.3.2) and record the presence of any new cracks developed during the freezing-thawing testing procedure. Measure and record the length of the new cracks. Examine the specimen for gradual disintegration during the freeze-thaw process.

9.4.3 *Rating*—A specimen is considered to fail the freezing and thawing test under any one of three circumstances:

9.4.3.1 *Weight Loss*—A gradual disintegration resulting in a weight loss of greater than that required by the referenced unit specification for the appropriate classification.

9.4.3.2 *Breakage*—The specimen separates into two or more pieces, or

9.4.3.3 *Cracking*—A specimen develops a crack during the freezing and thawing procedure that exceeds in length the minimum dimension of the specimen.

If none of the above circumstances occur, the specimens are considered to pass the freezing and thawing test.

9.4.4 *Report*—The report shall state whether the sample passed or failed the test. Any failures shall include the rating and the reason for classification as a failure and the number of cycles causing failure in the event failure occurs prior to 50 cycles.

10. Initial Rate of Absorption (Suction) (Laboratory Test)

10.1 Apparatus:

10.1.1 *Trays or Containers*—Watertight trays or containers, having an inside depth of not less than $\frac{1}{2}$ in. (12.7 mm), and of such length and width that an area of not less than 300 in.²

(1935.5 cm²) of water surface is provided. The bottom of the tray shall provide a plane, horizontal upper surface, when suitably supported, so that an area not less than 8 in. (203.2 mm) in length by 6 in. (152.4 mm) in width will be level when tested by a spirit level.

10.1.2 *Supports for Brick*—Two noncorrodible metal supports consisting of bars between 5 and 6 in. (127.00 and 152.5 mm) in length, having triangular, half-round, or rectangular cross sections such that the thickness (height) will be approximately $\frac{1}{4}$ in. (6.35 mm). The thickness of the two bars shall agree within 0.001 in. (0.03 mm) and, if the bars are rectangular in cross section, their width shall not exceed $\frac{5}{16}$ in. (1.94 mm).

10.1.3 *Means for Maintaining Constant Water Level*—Suitable means for controlling the water level above the upper surface of the supports for the brick within ± 0.01 in. (0.25 mm) (see Note 5), including means for adding water to the tray at a rate corresponding to the rate of removal by the brick undergoing test (see Note 6). For use in checking the adequacy of the method of controlling the rate of flow of the added water, a reference brick or half brick shall be provided whose displacement in $\frac{1}{8}$ in. (3.18 mm) of water corresponds to the brick or half brick to be tested within ± 2.5 %. Completely submerge the reference brick in water for not less than 3 h preceding its use.

NOTE 5—A suitable means for obtaining accuracy in control of the water level may be provided by attaching to the end of one of the bars two stiff metal wires that project upward and return, terminating in points; one of which is $\frac{1}{8} - 0.01$ in. (3.18 - 0.25 mm) and the other $\frac{1}{8} + 0.01$ in. (3.18 + 0.25 mm) above the upper surface or edge of the bar. Such precise adjustment is obtainable by the use of depth plates or a micrometer microscope. When the water level with respect to the upper surface or edge of the bar is adjusted so that the lower point dimples the water surface when viewed by reflected light and the upper point is not in contact with the water, the water level is within the limits specified. Any other suitable means for fixing an maintaining a constant depth of immersion may be used if equivalent accuracy is obtained. As an example of such other suitable means, there may be mentioned the use of rigid supports movable with respect to the water level.

NOTE 6—A rubber tube leading from a siphon or gravity feed and closed by a spring clip will provide a suitable manual control. The so-called “chicken-feed” devices as a rule lack sensitivity and do not operate with the very small changes in water level permissible in this test.

10.1.4 *Balance*, having a capacity of not less than 3000 g, and sensitive to 0.5 g.

10.1.5 *Drying Oven*, conforming to the requirements of 9.1.4.

10.1.6 *Constant-Temperature Room*, maintained at a temperature of $70 \pm 2.5^\circ\text{F}$ ($21 \pm 1.4^\circ\text{C}$).

10.1.7 *Timing Device*—A suitable timing device, preferably a stop watch or stop clock, which shall indicate a time of 1 min to the nearest 1 s.

10.2 *Test Specimens*, consisting of whole brick. Five specimens shall be tested.

10.3 Procedure:

10.3.1 The initial rate of absorption shall be determined for the test specimen as specified, either oven-dried or ambient air-dried. If not specified, the initial rate of absorption shall be determined for the test specimens oven-dried. Dry and cool the test specimens in accordance with the applicable procedures



10.3.1.1 or 10.3.1.2. Complete the test procedure in accordance with 10.3.2, 10.3.3, and 10.3.4.

NOTE 7—There is no correlated relationship between the value of initial rate of absorption for ambient air-dried and oven-dried units. The test methods provide different information.

10.3.1.1 *Oven-dried Procedure*—Dry and cool the test specimens in accordance with 5.1.1 and 5.1.2.

10.3.1.2 *Ambient Air-dried Procedure*—Store units unstacked, with separate placement in a ventilated room maintained at a temperature of $75 \pm 15^\circ\text{F}$ ($24 \pm 8^\circ\text{C}$) with a relative humidity between 30 % and 70 % for a period of 4 h, with a current of air from an electric fan passing over them for a period of at least 2 h. Continue until two successive weighings at intervals of 2 h show an increment of loss not greater than 0.2 % of the last previously determined weight of the specimen.

10.3.2 Measure to the nearest 0.05 in. (1.27 mm) the length and width of the flatwise surface of the test specimen of rectangular units or determine the area of other shapes to similar accuracy that will be in contact with the water. Weigh the specimen to the nearest 0.5 g.

10.3.3 Adjust the position of the tray for the absorption test so that the upper surface of its bottom will be level when tested by a spirit level, and set the saturated reference brick (10.1.3) in place on top of the supports. Add water until the water level is $\frac{1}{8} \pm 0.01$ in. (3.18 ± 0.25 mm) above the top of the supports. When testing tile with scored bed surfaces, the depth of water level is $\frac{1}{8} \pm 0.01$ in. plus the depth of scores.

10.3.4 After removal of the reference brick, set the test brick in place flatwise, counting zero time as the moment of contact of the brick with the water. During the period of contact (1 min \pm 1 s) keep the water level within the prescribed limits by adding water as required. At the end of 1 min \pm 1 s, lift the brick from contact with the water, wipe off the surface water with a damp cloth, and reweigh the brick to the nearest 0.5 g. Wiping shall be completed within 10 s of removal from contact with the water, and weighing shall be completed within 2 min.

NOTE 8—Place the brick in contact with the water quickly, but without splashing. Set the brick in position with a rocking motion to avoid the entrapping of air on its under surface. Test brick with frogs or depressions in one flatwise surface with the frog or depression uppermost. Test molded brick with the struck face down.

10.4 Calculation and Report:

10.4.1 The difference in weight in grams between the initial and final weighings is the weight in grams of water absorbed by the brick during 1-min contact with the water. If the area of its flatwise surface (length times width) does not differ more than ± 0.75 in.² (4.84 cm²) (± 2.5 %) from 30 in.² (193.55 cm²), report the gain in weight of each specimen to the nearest 0.1 g, as its initial rate of absorption in 1 min.

10.4.2 If the area of its flatwise surface differs more than ± 0.75 in.² (4.84 cm²) (± 2.5 %) from 30 in.² (193.55 cm²), calculate the equivalent gain in weight from 30 in.² (193.55 cm²) of each specimen to the nearest 0.1 g as follows:

$$X = 30 W / LB \text{ (metric } X = 193.55 W / LB) \quad (6)$$

where:

X = gain in weight corrected to basis of 30 in.² (193.55 cm²) flatwise area,

W = actual gain in weight of specimen, g,

L = length of specimen, in., (cm), and

B = width of specimen, in., (cm).

10.4.3 Report the corrected gain in weight, X , of each specimen to the nearest 0.1 g, as the initial rate of absorption in 1 min.

10.4.4 If the test specimen is a cored brick, calculate the net area and substitute for LB in the equation given in 10.4.2. Report the corrected gain in weight, X , of each specimen to the nearest 0.1 g, as the initial rate of absorption in 1 min.

10.4.5 If specimen is non-prismatic, calculate the net area by suitable geometric means and substitute for LB in the equation given in 10.4.2.

10.5 Calculate and report the average initial rate of absorption of all specimens tested to the nearest 0.1 g/min/30 in.² (193.55 cm²).

10.6 Report the method of drying as oven-dried (in accordance with 10.3.1.1) or ambient air-dried (in accordance with 10.3.1.2).

11. Efflorescence

11.1 Apparatus:

11.1.1 *Trays and Containers*—Watertight shallow pans or trays made of corrosion-resistant metal or other material that will not provide soluble salts when in contact with distilled water containing leachings from brick. The pan shall be of such dimensions that it will provide not less than a 1-in. (25.4-mm) depth of water. Unless the pan provides an area such that the total volume of water is large in comparison with the amount evaporated each day, suitable apparatus shall be provided for keeping a constant level of water in the pan.

11.1.2 *Drying Room*, conforming to the requirements of 9.1.6.

11.1.3 *Drying Oven*, conforming to the requirements of 9.1.4.

11.2 Test Specimens:

11.2.1 The sample shall consist of ten full-size brick.

11.2.2 The ten specimens shall be sorted into five pairs so that both specimens of each pair will have the same appearance as nearly as possible.

11.3 *Preparation of Specimens*—Remove by brushing any adhering dirt that might be mistaken for efflorescence. Dry the specimens and cool them as prescribed in 5.1.1 and 5.1.2.

11.3.1 Calculate the weight per unit area of each specimen as follows:

$$W_a = \frac{nW_d}{A_{fa1} + A_{fa2}} \quad (7)$$

Where:

W_a = weight per unit area of the specimen, lb/sq. ft. (kg. m²),

n = number of faces of the specimen (1 for split tile units or 2 for all other units)

W_d = dry weight of the specimen, lb (kg),

A_{fa1} = area (height \times length) of finished face of specimen, sq. ft. (m²), and

A_{fa2} = area (height \times length) of back face of specimen, sq. ft. (m²).

11.3.2 Report the results of Eq. 7 in 11.3.1 separately for each unit and the average for all specimens tested.

11.4 Procedure:

11.4.1 Set one specimen from each of the five pairs, on end, partially immersed in distilled water to a depth of approximately 1 in. (25.4 mm) for 7 days in the drying room. When several specimens are tested in the same container, separate the individual specimens by a spacing of at least 2 in. (50.8 mm).

NOTE 9—Do not test specimens from different sources simultaneously in the same container, because specimens with a considerable content of soluble salts may contaminate salt-free specimens.

NOTE 10—Empty and clean the pans or trays after each test.

11.4.2 Store the second specimen from each of the five pairs in the drying room without contact with water.

11.4.3 At the end of 7 days, inspect the first set of specimens and then dry both sets in the drying oven for 24 h.

11.5 *Examination and Rating*—After drying, examine and compare each pair of specimens, observing the top and all four faces of each specimen from a distance of 10 ft. (3 m) under an illumination of not less than 50 footcandles (538.2 lm/m²) by an observer with normal vision. If under these conditions no difference is noted, report the rating as “not effloresced.” If a perceptible difference due to efflorescence is noted under these conditions, report the rating as “effloresced.” Report the appearance and distribution of the efflorescence.

11.6 *Precision and Bias*—No information is presented about either the precision or bias of the test method for efflorescence because the test result is nonquantitative.

12. Weight per Unit Area

12.1 *Apparatus*—A scale or balance sensitive to within 0.2 % of the weight of the smallest specimen.

12.2 *Test Specimens*—Weigh five dry full size structural clay tile units (see 5.1.1).

12.3 Calculation and Report:

12.3.1 Calculate the weight per unit area of a specimen by dividing the total weight in pounds by the average area in square feet of the two faces of the unit as normally laid in a wall.

12.3.2 Report results separately for each specimen to the nearest 1 g, with the average to the nearest 1 g.

13. Measurement of Size

13.1 *Apparatus*—Either a 1-ft (or metric) steel rule, graduated in $\frac{1}{32}$ -in. (or 1-mm) divisions, or a gage or caliper having a scale ranging from 1 to 12 in. (25 to 300 mm), and having parallel jaws, shall be used for measuring the individual units. Steel rules or calipers of corresponding accuracy and size required shall be used for measurement of larger brick, solid masonry units, and tile.

13.2 *Test Specimens*—Measure ten whole dry full-size units. These units shall be representative of the lot and shall include the extremes of color range and size as determined by visual inspection. (The same samples may be used for determining efflorescence and other properties.)

13.3 *Individual Measurements of Width, Length, and Height*—Measure the width across both ends and both beds from the midpoints of the edges bounding the faces. Record these four measurements to the nearest $\frac{1}{32}$ in. (1 mm) and record the average to the nearest $\frac{1}{64}$ in. (0.5 mm) as the width.

Measure the length along both beds and along both faces from the midpoints of the edges bounding the ends. Record these four measurements to the nearest $\frac{1}{32}$ in. (1 mm) and record the average to the nearest $\frac{1}{64}$ in. (0.5 mm) as the length. Measure the height across both faces and both ends from the midpoints of the edges bounding the beds. Record these four measurements to the nearest $\frac{1}{32}$ in. (1 mm) and record the average to the nearest $\frac{1}{64}$ in. (0.5 mm) as the height. Use the apparatus described in 13.1. Retest by the same method when required.

13.4 *Report*—Report the average width, length, and height of each specimen tested to the nearest $\frac{1}{32}$ in. (0.8 mm).

14. Measurement of Warpage

14.1 Apparatus:

14.1.1 Steel Straightedge:

14.1.2 *Rule or Measuring Wedge*—A steel rule graduated from one end in $\frac{1}{32}$ -in. (or 1-mm) divisions, or alternatively, a steel measuring wedge 2.5 in. (60 mm) in length by 0.5 in. (12.5 mm) in width by 0.5 in. (12.5 mm) in thickness at one end and tapered, starting at a line 0.5 in. (12.5 mm) from one end, to zero thickness at the other end. The wedge shall be graduated in $\frac{1}{32}$ -in. (or 1-mm) divisions and numbered to show the thickness of the wedge between the base, AB, and the slope, AC, Fig. 1.

14.1.3 *Flat Surface*, of steel or glass, not less than 12 by 12 in. (305 by 305 mm) and plane to within 0.001 in. (0.025 mm).

14.2 *Sampling*—Use the sample of ten units selected for determination of size.

14.3 *Preparation of Samples*—Test the specimens as received, except remove any adhering dirt by brushing.

14.4 Procedure:

14.4.1 *Concave Surfaces*—Where the warpage to be measured is of a surface and is concave, place the straightedge lengthwise or diagonally along the surface to be measured, selecting the location that gives the greatest departure from straightness. Select the greatest distance from the unit surface to the straightedge. Using the steel rule or wedge, measure this distance to the nearest $\frac{1}{32}$ in. (1 mm), and record as the concave warpage of the surface.

14.4.2 *Concave Edges*—Where the warpage to be measured is of an edge and is concave, place the straightedge between the ends of the concave edge to be measured. Select the greatest

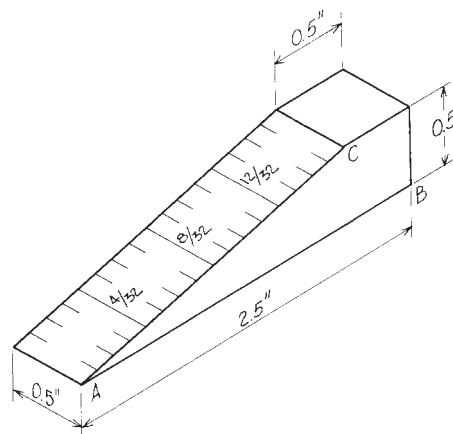

FIG. 1 Measuring Wedge

distance from the unit edge to the straightedge. Using the steel rule or wedge, measure this distance to the nearest $\frac{1}{32}$ in. (1 mm), and record as the concave warpage of the edge.

14.4.3 *Convex Surfaces*—When the warpage to be measured is of a surface and is convex, place the unit with the convex surface in contact with a plane surface and with the corners approximately equidistant from the plane surface. Using the steel rule or wedge, measure the distance to the nearest $\frac{1}{32}$ in. (1 mm) of each of the four corners from the plane surface. Record the average of the four measurements as the convex warpage of the unit.

14.4.4 *Convex Edges*—Where the warpage to be measured is of an edge and is convex, place the straightedge between the ends of the convex edge. Select the greatest distance from the unit edge to the straightedge. Using the steel rule or wedge, measure this distance to the nearest $\frac{1}{32}$ in. (1 mm) and record as the convex warpage of the edge.

14.5 *Report*—Report all recorded warpage measurements of each specimen tested to the nearest $\frac{1}{32}$ in. (0.8 mm).

15. Measurement of Length Change

15.1 *Apparatus*—A dial micrometer or other suitable measuring device graduated to read in 0.0001-in. (or 0.001-mm) increments, mounted on a stand suitable for holding the specimen in such a manner that reproducible results can be obtained, shall be used for measuring specimen length. Provisions shall be made to permit changing the position of the dial micrometer on its mounting rod so as to accommodate large variations in specimen size. The base of the stand and the tip of the dial micrometer shall have a conical depression to accept a $\frac{1}{4}$ -in. (6.35-mm) steel ball. A suitable reference instrument shall be provided for checking the measuring device.

15.2 *Preparation of Specimen*—Remove the ends of deeply textured specimens to the depth of the texture by cutting perpendicular to the length and parallel to each other. Drill a hole in each end of the specimen with a $\frac{1}{4}$ -in. (6.35-mm) carbide drill. Drill these holes at the intersection of the two diagonals from the corners. Place $\frac{1}{4}$ -in. (6.35-mm) steel balls in these depressions by cementing in place with a calcium aluminate cement. Any equivalent method for establishing the reference length is permissible.

15.3 *Procedure*—Mark the specimen for identification and measure to the nearest 0.0001 in. (or 0.001 mm) in a controlled environment and make subsequent measurements in the same controlled environment, $\pm 2^\circ\text{F}$ and $\pm 5\%$ relative humidity. Record the temperature and relative humidity. Apply a reference mark to the specimen for orientation in the measuring device. Check the measuring device with the reference instrument before each series of measurements.

15.4 *Report*—When more than one specimen is tested, calculate and report the average length change of all specimens to the nearest 0.0001 in. (0.001 mm). The report shall include all individual recordings as well as the recorded laboratory temperature and relative humidity.

16. Initial Rate of Absorption (Suction)—Field Test

16.1 *Scope*—This test method is intended to serve as a volumetric means of determining the initial rate of absorption (IRA) of any size brick when weighing determination, de-

scribed in Section 10 of these test methods, is impractical. This test method is applicable to assess the need for wetting the brick. This test method is performed on specimens taken from the field with no modification of moisture content, therefore, the IRA determined by this test method may differ from the IRA determined by the laboratory test method in Section 10, which requires drying the specimens.

16.2 Apparatus:

16.2.1 *Absorption Test Pan*—A watertight, rectangular pan, constructed of noncorroding material, with a flat, rigid bottom and inside depth of about $1\frac{1}{2}$ in. (38.1 mm). The inside length and width of the pan shall exceed the length and width of the tested brick by a minimum of 3 in. (76.2 mm) but not more than 5 in. (127.0 mm).

16.2.2 *Brick Supports*—Two noncorroding rectangular bars, $\frac{1}{4}$ in. (6.4 mm) in height and width and 1 in. (25.4 mm) shorter than the inside width of the pan in length. The brick supports can be placed on the bottom of the pan just before the test or permanently affixed to the bottom of the pan. The space between the supports should be about 4 in. (101.6 mm) shorter than the length of the tested brick. A device indicating the desired water level can be permanently attached to the end of one of the brick supports or suspended from the top of the pan (see Fig. 2 (a) and (b)). Any other device of equivalent accuracy for controlling the required water level, $\frac{1}{8}$ in. (3.2 mm) above the brick supports, can be used in place of that depicted in Fig. 2.

16.2.3 *Timing Device*—A suitable timing device that shall indicate a time of 1 min to the nearest 1 s.

16.2.4 *Squeeze Bottle*—A plastic squeeze bottle, 100 mL capacity.

16.2.5 *Graduated Cylinder*—A plastic or glass graduated measuring cylinder, 100 mL capacity.

16.3 *Test Specimens*—Select six whole brick in accordance with the requirements of Paragraph 4.1.

16.4 Procedure:

16.4.1 Completely immerse one brick specimen in a container of water for 2 h.

16.4.2 Measure to the nearest $\frac{1}{16}$ in. (1.6 mm) the length and width of the five remaining specimens at the surface that will be in contact with water. If the test specimens are cored, determine the area of the cores at the same surface.

16.4.3 Pre-wet and drain the absorption pan and place it on a flat, level surface.

16.4.4 Remove the pre-wetted specimen from the container, shake off the surface water, and place the specimen on brick

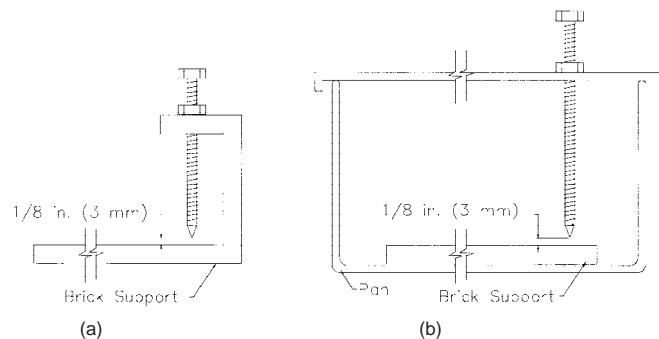

FIG. 2 Water Level Indicators



supports in the pan. Pour water into the pan until the water reaches a level $\frac{1}{8}$ in. (3.2 mm) above the brick supports. (If using a pointed level water indicator, pour water into the pan until the water makes a minimum contact (dimpling effect).) Remove the pre-wetted brick, and tilt the brick sharply so that one corner serves as a drip point for clinging surface water to return to the pan. A gentle shake of the brick may be necessary to make the last drop fall. Put the pre-wetted brick back into the container of water.

16.4.5 Using the graduated cylinder, fill the squeeze bottle with exactly 100 mL of water.

16.4.6 Set the first test specimen squarely on the brick supports, counting zero time as the moment the brick contacts the water. At the end of 1 min \pm 1 s lift the test specimen from water and tilt the brick sharply so that one corner serves as a drip point for clinging surface water to return to the pan. A gentle shake of the brick may be necessary to make the last drop fall.

16.4.6.1 Continue setting the remaining test specimens into the pan in the same way until all five specimens are tested. During the test add water to the pan, using the squeeze bottle, to keep the water level approximately constant at the $\frac{1}{8}$ in. depth. Refill the squeeze bottle with 100 mL of water when empty, recording each refill.

16.4.6.2 After the last specimen is tested, place the pre-wetted brick back in the pan and restore the original level with water from the squeeze bottle.

NOTE 11—Place the brick in contact with the water quickly, but without splashing. Set the brick in position with a rocking motion to avoid the entrapping of air on its under surface. Test brick with frogs or depressions in one flatwise surface with the frog or depression uppermost. Test molded brick with the struck face down.

16.4.7 Using the graduated cylinder, measure the volume of water remaining in the squeeze bottle.

16.5 Calculation and Report:

16.5.1 The number of refills plus the first full bottle, times 100 mL, minus the volume of water remaining in the squeeze bottle, is the total measured volume of water in milliliters absorbed by the five specimens.

$$V_t = 100(n + 1) - V_r \quad (8)$$

where:

V_t = total measured volume of water absorbed by all tested specimens, mL,

n = the number of squeeze bottle refills, and

V_r = the volume of water remaining in the squeeze bottle, mL.

16.5.2 When the average net surface area in contact with water of a single specimen (sum of net surface areas divided by the number of specimens) differs by ± 0.75 in.² (4.84 cm²) or less from 30 in.² (193.5 cm²), report the total measured absorbed volume of water divided by five, the number of tested specimens, as the IRA (Field) in g/min/30 in.²

$$\text{IRA (Field)} = \frac{V_t}{5} \quad (9)$$

16.5.3 If the average net surface area in contact with water differs by more than ± 0.75 in.² (4.84 cm²) from 30 in.² (193.5

cm²), calculate the equivalent volume in 1 min for 30 in.² (193.5 cm²) of surface as follows:

$$V_c = \frac{30 V_t}{A_n} \left(\text{metric } V_c = \frac{193.5 V_t}{A_n} \right) \quad (10)$$

where:

V_c = average volume of absorbed water by a specimen, corrected to basis of 30 in.² (193.5 cm²) of surface, mL, and

A_n = sum of net surface areas in contact with water of all tested specimens, in.² (cm²).

16.5.4 *Report*—Report the corrected volume (V_c) as the IRA (Field) in g/l min/30 in.²

16.6 *Precision and Bias*—Insufficient data is currently available for a precision and bias statement.

17. Measurement of Void Area in Cored Units

17.1 Apparatus:

17.1.1 *Steel Rule or Calipers*—As described in 13.1.

17.1.2 *Graduated Cylinder*—A glass cylinder with a capacity of 500 mL.

17.1.3 *Paper*—A sheet of smooth, hard-finish paper not less than 24 by 24 in. (610 by 610 mm).

17.1.4 *Sand*—500 mL of clean, dry sand.

17.1.5 *Steel Straightedge*.

17.1.6 *Flat Surface*—A level, flat, smooth, clean dry surface.

17.1.7 *Brush*—A soft-bristle brush.

17.1.8 *Neoprene Mat*—24 by 24 in. (610 by 610 mm) open-cell neoprene sponge $\frac{1}{4}$ in. (6.4 mm) in thickness.

17.1.9 *Balance*—See 10.1.4.

17.2 *Test Specimens*—Use of a sample of ten units selected as described for the determination of size (The samples taken for the determination of size may be used).

17.3 *Preparation of Samples*—Test the specimens as received, except remove any adhering dirt by brushing.

17.4 Procedure:

17.4.1 Measure and record the length, width, and depth of the unit as described for the determination of size.

17.4.2 Place the unit to be tested bed down (cores vertical) on the sheet of paper that has been spread over the neoprene mat on the flat surface.

17.4.3 Fill the cores with sand, allowing the sand to fall naturally. Do not work the sand into the cores. Using the steel straightedge, bring the level of the sand in the cores down to the top of the unit. With the brush, remove all excess sand from the top of the unit and from the paper sheet.

17.4.4 Lifting the unit up, allow all of the sand in the cores to fall on the sheet of paper.

17.4.5 Transfer the sand from the sheet of paper to the balance, weighing and recording to the nearest 0.5 g.

17.4.6 With a separate portion of the sand, fill a 500 mL cylinder to the exact 500 mL graduation by allowing the sand to fall naturally and without shaking or vibrating the cylinder. Transfer this sand to the balance, weighing and recording to the nearest 0.5 g.

17.5 Calculation and Report:

17.5.1 Determine the volume of sand held in the test unit as follows:

$$V_s = \frac{500 \text{ mL}}{S_c} \times S_u \quad (11)$$

where:

- V_s = volume of sand held in test unit,
- S_c = weight, in grams, of 500 mL sand contained in graduated cylinder, and
- S_u = weight in grams of sand held in test unit.

17.5.2 Determine the percentage of void as follows:

$$\% \text{ Void area} = \frac{V_s}{V_u} \times \frac{1}{16.4} \times 100 \quad (12)$$

where:

- V_s = volume of sand determined in 17.5.1, mL, and
- V_u = length \times width \times depth recorded in 17.4.1, in.³

17.5.3 Report the results of Eq 12 in 17.5.2 for each specimen to the nearest 1 %, as the unit's percentage of void area.

18. Measurement of Void Area In Deep Froged Units

NOTE 12—The area measured corresponds to a section located $\frac{3}{8}$ in. (9.5 mm) distant from the voided bed of the units.

18.1 Apparatus:

18.1.1 *Steel Rule or Gage or Calipers* (inside and outside)— as described in 13.1.

18.1.2 *Steel Straightedge*.

18.1.3 *Marking Pen or Scribe*.

18.2 *Test Specimens*—Use a sample of 10 units selected as described for the determination of size. (The samples taken for the determination of size may be used.)

18.3 *Preparation of Sample*—Test the specimens as received except remove any adhering dirt by brushing.

18.4 Procedure:

18.4.1 Measure the length along both faces and the width along both ends at a distance of $\frac{3}{8}$ in. (9.5 mm) down from the bed containing the deep frogs. Record the measurements to the nearest $\frac{1}{32}$ in. (1 mm). Record the average of the two length measurements to the nearest $\frac{1}{32}$ in. (1 mm) as the length of the unit and the average of the two width measurements to the nearest $\frac{1}{32}$ in. (1 mm) as the width of the unit.

18.4.2 With the steel straightedge parallel to the length of the unit and centered over the deep frog or frogs, inscribe a mark on both faces of the frog $\frac{3}{8}$ in. (9.5 mm) below the underside of the steel straightedge (mark 1 on Fig. 3). With the steel straightedge parallel to the width of the unit and centered over the deep frog, inscribe a mark on both faces of each frog $\frac{3}{8}$ in. (9.5 mm) below the underside of the steel straightedge (mark 2 on Fig. 3).

18.4.3 Measure and record to the nearest $\frac{1}{32}$ in. (1 mm) the distance between the inscribed marks on a line parallel to the length of the unit for each frog, and measure and record to the nearest $\frac{1}{32}$ in. (1 mm) the distance between the inscribed marks on a line parallel to the width of the unit for each frog.

18.5 Calculations and Report:

18.5.1 Using the recorded length and width measurements calculate the gross area of the unit (A_u) in the plane of the unit $\frac{3}{8}$ in. (9.5 mm) down from the froged bed.

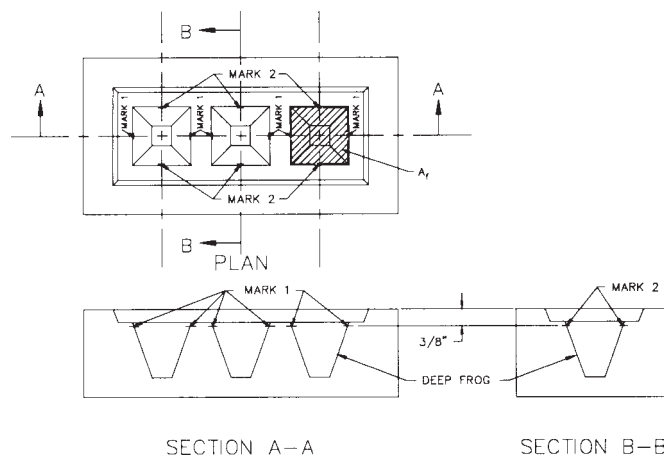

FIG. 3 Deep Froged Units

18.5.2 Using the distance between the inscribed marks calculate the inside area of each deep frog (A_f) in the plane of the unit $\frac{3}{8}$ in. (9.5 mm) down from the froged bed (see Fig. 3).

18.5.3 Determine the percentage of void as follows:

$$\% \text{ Void area} = \frac{\sum A_f \times 100}{A_u} \quad (13)$$

where:

- $\sum A_f$ = sum of the inside area of the deep frogs, and
- A_u = gross area of unit.

18.5.4 Report the results of the equation in 18.5.3 for each specimen to the nearest 1 %, as the unit's percentage of void area.

19. Measurement of Out of Square

19.1 Apparatus:

19.1.1 *Steel Rule or Calipers*, as described in 13.1.

19.1.2 *Steel Carpenter's Square*.

19.2 Procedure:

19.2.1 Place one leg of a carpenter's square adjacent to the length of the unit when laid as a stretcher. Align the leg of the square parallel to the length of the unit by having the corners of the face of the unit in contact with the leg of the square.

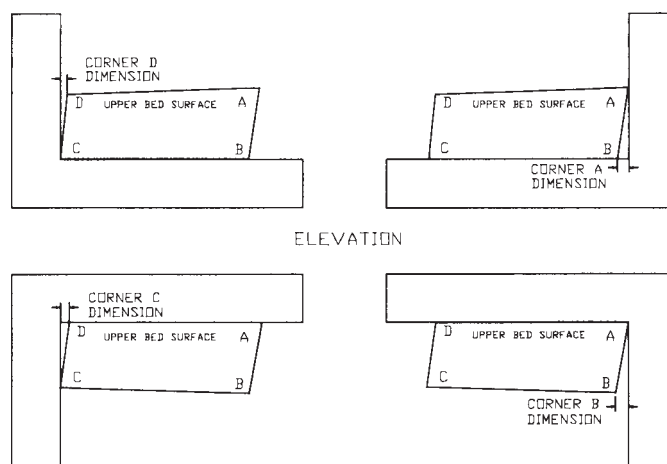

FIG. 4 Out-of-Square Measurements

Locate the square parallel to and at or within $\frac{1}{4}$ in. (6.4 mm) of the face to be exposed. See Fig. 5.

19.2.2 Measure the deviation due to the departure from the 90° angle at each corner of the exposed face of the unit. Record the measurement to the nearest $\frac{1}{32}$ in. (0.8 mm) for each corner. See Fig. 4.

19.3 Report—Report the recorded measurements for each specimen tested to the nearest $\frac{1}{32}$ in. (0.8 mm) as the unit's deviation from square.

20. Measurement of Shell and Web Thickness

20.1 Apparatus—a caliper rule graduated in not more than $\frac{1}{64}$ in. (0.4 mm) divisions and having parallel jaws not less than $\frac{1}{2}$ in. (12.7 mm) in length.

20.2 Test Specimens—Use a sample of five units as described for the measurement of size (samples taken for the determination of size are permitted to be used).

20.3 Preparation of Samples—Remove any shards or other projections interfering with measurement of the minimum parallel distance of two surfaces.

20.4 Procedure—For each unit, measure the shell thicknesses and, when required, the web thicknesses at the thinnest point of each element $\frac{1}{2}$ in. (12.7 mm) into the unit from either direction and record to the nearest division of the caliper.

NOTE 13—Current ASTM specifications for solid masonry units from clay or shale do not include minimum web thickness requirements.

21. Breaking Load

21.1 Test Specimens—The test specimens shall consist of whole full-size units (see 5.1.1). Five such specimens shall be tested.

21.2 Procedure:

21.2.1 Test units that have been dried according to 5.1.1.

21.2.2 Unless specified and reported otherwise, support the test specimen flatwise (that is, apply the load in the direction of

the height of the unit). The load shall be placed at the midspan, within $\frac{1}{16}$ in. (2 mm) of the center. If the specimens have frogs or depressions, place the specimen so that the frogs or depressions are on the underside of the specimen. The supports for the specimen shall be solid steel rods $1 \pm \frac{3}{8}$ in. (25.4 ± 10 mm) in diameter placed $\frac{1}{2} \pm \frac{1}{16}$ in. (12.7 ± 2 mm) from each end. The length of each support shall be at least equal to the width of the specimen. See Fig. 6.

21.2.3 Apply the load to the upper surface of the specimen through a steel bearing plate $\frac{1}{4}$ in. (6.4 mm) in thickness and $1\frac{1}{2}$ in. (38.1 mm) in width and of a length at least equal to the width of the specimen.

21.2.4 Speed of Testing—The rate of loading shall not exceed 2000 lbf (8896 N)/min. This requirement shall be considered as being met if the speed of the moving head of the testing machine immediately prior to application of the load is not more than 0.05 in. (1.27 mm)/min.

21.3 Report:

21.3.1 Record the unit dimensions and span length.

21.3.2 Record the transverse breaking load, P , of each unit to the nearest lb (N).

21.3.3 Calculate and record the breaking load per width of unit as $p = P/w$ for each unit, lb/in. (N/mm). Report the average of the breaking loads per width of all the specimens tested as the breaking load of the lot.

22. Keywords

22.1 absorption; compressive strength; efflorescence; freezing and thawing; initial rate of absorption; length change; modulus of rupture; out-of-square; sampling; size; void area; warpage

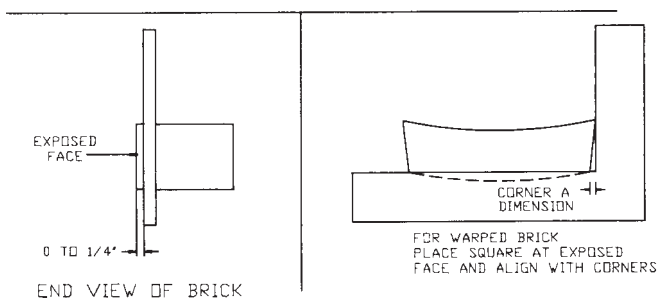

FIG. 5 Location of Carpenter's Square

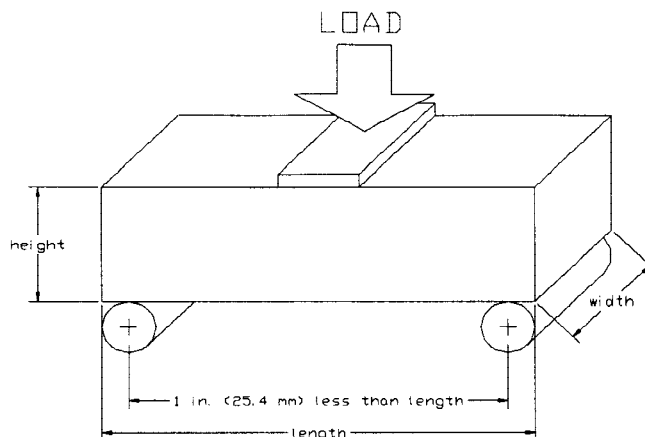

FIG. 6 Breaking Load Configuration



C 67 – 03

SUMMARY OF CHANGES

Committee C15 has identified the location of selected changes to this standard since C 67 – 02c that may impact the use of this standard.

- (1) Section 8.3.6 was revised to remove the alternate test procedure of conducting the test over 50 consecutive days.
- (2) Sections 11.3.1 and 11.3.2 were changed to include an equation for calculating the weight per unit area.
- (3) Section 4.1 was modified to provide clarity of specimen selection.

ASTM International takes no position respecting the validity of any patent rights asserted in connection with any item mentioned in this standard. Users of this standard are expressly advised that determination of the validity of any such patent rights, and the risk of infringement of such rights, are entirely their own responsibility.

This standard is subject to revision at any time by the responsible technical committee and must be reviewed every five years and if not revised, either reapproved or withdrawn. Your comments are invited either for revision of this standard or for additional standards and should be addressed to ASTM International Headquarters. Your comments will receive careful consideration at a meeting of the responsible technical committee, which you may attend. If you feel that your comments have not received a fair hearing you should make your views known to the ASTM Committee on Standards, at the address shown below.

This standard is copyrighted by ASTM International, 100 Barr Harbor Drive, PO Box C700, West Conshohocken, PA 19428-2959, United States. Individual reprints (single or multiple copies) of this standard may be obtained by contacting ASTM at the above address or at 610-832-9585 (phone), 610-832-9555 (fax), or service@astm.org (e-mail); or through the ASTM website (www.astm.org).