

This document is not an ASTM standard and is intended only to provide the user of an ASTM standard an indication of what changes have been made to the previous version. Because it may not be technically possible to adequately depict all changes accurately, ASTM recommends that users consult prior editions as appropriate. In all cases only the current version of the standard as published by ASTM is to be considered the official document.



Designation: C 868 – 85 (Reapproved 1995)^{€1}



Designation: C 868 – 02

Standard Test Method for Chemical Resistance of Protective Linings¹

This standard is issued under the fixed designation C 868; the number immediately following the designation indicates the year of original adoption or, in the case of revision, the year of last revision. A number in parentheses indicates the year of last reapproval. A superscript epsilon (ε) indicates an editorial change since the last revision or reapproval.

~~ε¹ Note – The safety caveat was updated and Keywords were added in September 1995.~~

¹ This test method is under the jurisdiction of ASTM Committee C-3 C03 on Chemical-Resistant Nonmetallic Materials and is the direct responsibility of Subcommittee C03.01 on Test Methods.

Current edition approved ~~Aug. 30, 1985; Oct. 10, 2002.~~ Published ~~October 1985; December 2002.~~ Originally published as C 868 – 77. Last previous edition C 868 – 77(1995)^{ε1}.

1. Scope

1.1 This test method covers a procedure for evaluating the chemical resistance of a polymer-based protective lining applied to a steel substrate, in immersion service. The method closely approximates the service conditions, including the temperature differential between the external and internal surfaces of the equipment, which may accelerate permeation of the lining by a corrosive media.

1.2 This test method may be used to simulate actual field use conditions insofar as a qualitative evaluation of the lining system after a predetermined period of exposure.

1.23 *This standard does not purport to address all of the safety concerns, if any, associated with its use. It is the responsibility of the user of this standard to establish appropriate safety and health practices and determine the applicability of regulatory limitations prior to use.*

2. Referenced Documents

2.1 ASTM Standards:

A 36/A 36M Specification for Carbon Structural Steel²

A 285/A 285M Specification for Pressure Vessel Plates, Carbon Steel, Low- and Intermediate-Tensile Strength²

C 267 Test Methods for Chemical Resistance of Mortars, Grouts, and Monolithic Surfacing and Polymer Concretes³

D 471 Test Method for Rubber Property—Effect of Liquids⁴

D 714 Test Method for Evaluating Degree of Blistering of Paints⁵

D 785 Test Method for Rockwell Hardness of Plastics and Electrical Insulating Materials⁶

D 1474 Test Methods for Indentation Hardness of Organic Coatings⁵

D 2583 Test Method for Indentation Hardness of Rigid Plastics by Means of a Barcol Impressor⁷

D 3363 Test Method for Film Hardness by Pencil Test⁵

D 4417 Test Methods for Field Measurement of Surface Profile of Blast Cleaned Steel⁸

D 4541 Test Method for Pull-Off Strength of Coatings Using Portable Adhesion Testers⁸

D 5162 Practice for Discontinuity (Holiday) Testing of Nonconductive Protective Coating on Metallic Substrates⁸

2.2 NACE Standard:

~~TM-01-70 Visual Standard for Surfaces of New Steel Airblast Cleaned with Sand Abrasive⁸~~

² Annual Book of ASTM Standards, Vol 01.04.

³ Annual Book of ASTM Standards, Vol 04.05.

⁴ Annual Book of ASTM Standards, Vol 09.01.

⁵ Annual Book of ASTM Standards, Vol 06.01.

⁶ Annual Book of ASTM Standards, Vol 08.01.

⁷ Annual Book of ASTM Standards, Vol 08.02.

⁸ Available from the National Association

⁸ Annual Book of Corrosion Engineers (NACE), P.O. Box 218340, Houston, TX 77218; ASTM Standards, Vol 06.02.

2.3 *Steel Structures Painting Council Standard:*

SSPC

NACE No. 5—Blast Cleaning to “White” 1/SSPC-SP-5 White Metal Blast Cleaning⁹

3. Significance and Use

3.1 The results obtained by this test method should serve as a guide in, but not as the sole basis for, selection of a lining material for particular application. Simple chemical-resistance evaluations of the lining materials may be performed more conveniently by other pertinent methods as a prescreening test for this procedure in accordance with Test Methods C 267 and D 471.

4. Apparatus

4.1 *Four-Neck Cylindrical, Borosilicate-Type Glass Test Cell*¹⁰, similar to the unit shown in Fig. 1.

4.1.1 Where an additional inlet is needed for a thermocouple or thermistor to control temperature, a five-neck cell should be used.

NOTE 1—If test solutions that are known to attack glass such as HF or caustic, a fluorocarbon or other suitable cell should be used.

4.2 *Heating Equipment:*

4.2.1 The corrosive media may be heated by an electrical-resistant coil fitting inside the test cell. This is protected by a glass immersion tube. The heater shall be controlled through the use of a rheostat or thermostat to produce the desired temperature $\pm 4^{\circ}\text{F}$ (2°C).

4.2.2 An electrical heating tape may be wrapped around the exterior of the test cell but not around the test panels and may not touch the test panels.

4.3 *Reflux Water Condenser*, to maintain a constant level and concentration of ~~this~~ the test solution.

⁹ Available from the Steel Structures Painting Council (SSPC), 4400 Fifth Ave., Society for Protective Coatings, 40 24th St., Pittsburgh, PA 15213; 15222. Web address: <http://www.SSPC.org>

¹⁰ The sole source of supply of the four-neck cylindrical, borosilicate-type glass test cell known to the committee at this time is DeVal Glass Inc., 1135 E. 7th St., Wilmington, DE. If you are aware of alternative suppliers, please provide this information to ASTM International Headquarters. Your comments will receive careful consideration at a meeting of the responsible technical committee, which you may attend.

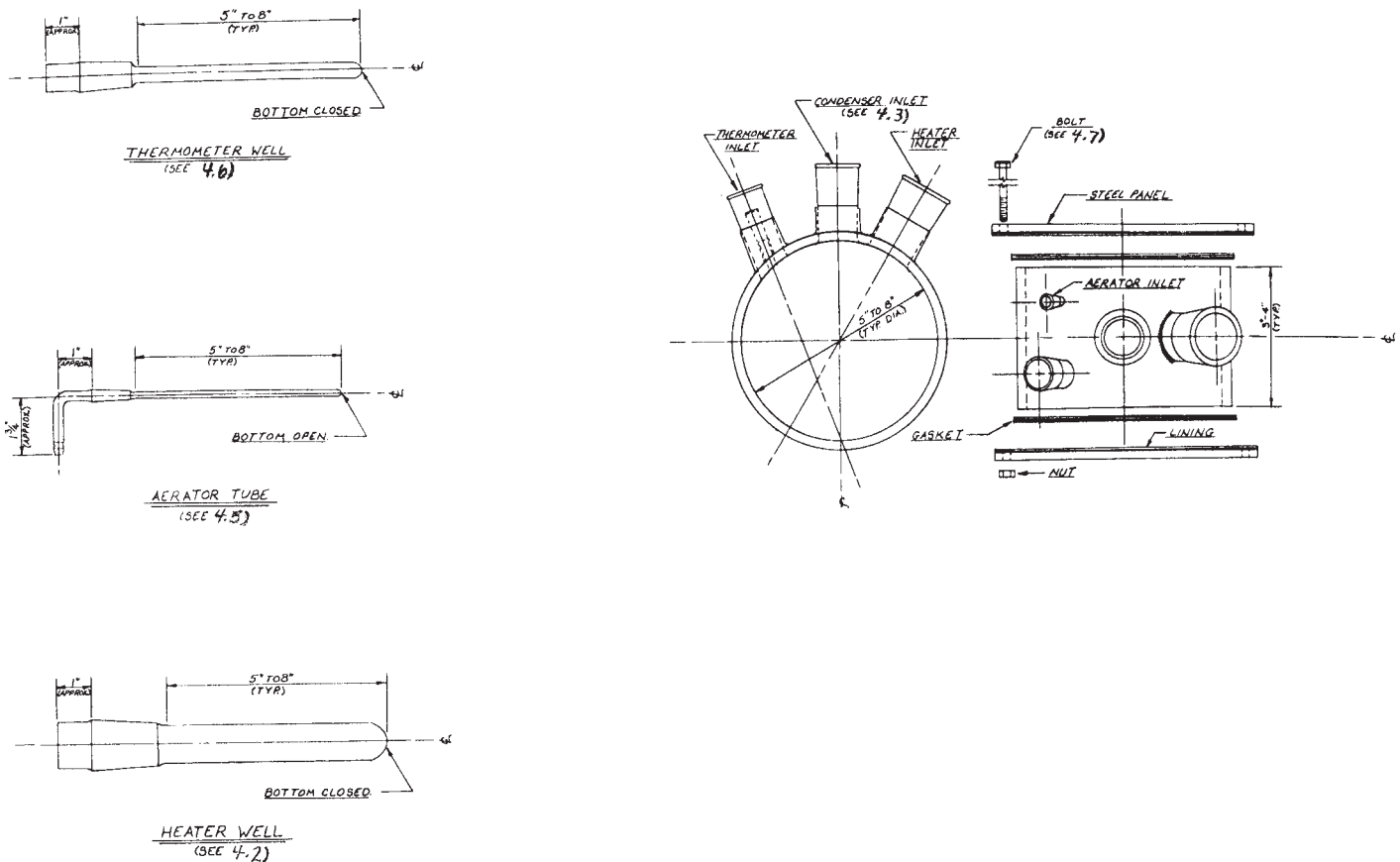

FIG. 1 Four-Neck Cylindrical, Borosilicate-Type Glass Test Cell and Accessories

4.4 *Gaskets*, of a chemically resistant material, capable of withstanding the chemical environment. The gaskets shall also provide a tight seal between the test cell and test specimen. ~~Neoprene, Hypalon, or Viton Gaskets having a Shore “A” gaskets (Shore “A” durometer Durometer of 60) 60~~ are generally adequate. The gasket material shall be selected so that it does not contaminate the test solution.

4.5 *Air or Gas Bubbler*—~~Normally, it will~~—It may be necessary to include an air or gas bubbler to agitate or aerate the solution. Where aeration is not required, a magnetic stirrer may be used to create agitation.

4.5.1 At solution temperatures below boiling, agitation is required to maintain temperature uniformity. Where the service solution is considered to be aerated, air should be bubbled into the solution. In cases where the solution will be air or oxygen depleted, nitrogen or other suitable inert gas should be used for agitation.

4.5.2 Insert a bubbler for air or other gas through the utility opening in the test cell. The bubbler shall consist of a piece of fluorocarbon or glass tubing $\frac{1}{8}$ in. (3 mm) in inside diameter, attached to the ground-glass fitting in the utility opening, and extending almost to the bottom of the test cell.

4.6 *Thermometer or Thermocouple*, to fit the prescribed thermowell, capable of registering the temperature ~~range involved in~~ specified for the test.

4.7 *Mounting Equipment (Alternatives):*

4.7.1 Mount the test panels on the test cell with a minimum of three carbon steel bolts, $\frac{1}{4}$ or $\frac{3}{8}$ in. (6 or 9 mm) in diameter, using wing nuts for easy removal.

4.7.2 “C” clamp fixtures or stainless steel band clamps or other suitable means can be used to mount the test panels to the test cell.

4.7.3 Use clamping pressures sufficient to seal the opening, but not so great as to destroy the test cell or test panel or damage the test coating—lining.

4.8 *Cell Test Area:*

4.8.1 The cells should be maintained in an open, well ventilated area with temperature controlled to $73 \pm 4^{\circ}\text{F}$ 4F° ($23 \pm 2^{\circ}\text{C}^{\circ}$).

4.8.2 The preferred method to ensure the free movement of air past the surfaces is to utilize grills or grating to support the cells with several inches of clearance beneath the grating to allow air flow past the plate surfaces. If this type of support is employed, cells should be at least 6 in. (152 mm) away from one another or any heat source.

4.8.3 If open grating support is not used, cells should be at least 12 in. (305 mm) from one another or from any potential source of heat. They should be placed on an open shelf or bench top in such a way that free convective cooling of the unlined side of the test panels may occur.

5. Test Specimens

5.1 *Substrate:*

5.1.1 Panels shall be commercial quality, unused, hot-rolled carbon steel (Specifications A 36/A 36M or A 285/A 285M) $\frac{1}{4}$ by 8 by 8 in. (6 by 200 by 200 mm).

~~5.1.2 This test~~

~~NOTE 2—With appropriate modification and procedures, this method can also be used for evaluation of to evaluate linings on other metallic substrates such as stainless steel or other alloys, copper, aluminum, etc.~~

~~5.1.3 With appropriate modifications etc., and procedures, this method can be used to evaluate linings on concrete, fiber reinforced plastic (FRP), or other substrates.~~

5.2 Prepare one side of the panels according to the surface conditions of NACE Standard No. 1-TM-01-70 or Steel Structures Painting Council SSPC No. 5. Measure SSPC-SP-5. The profile depth of the cleaned steel shall be as recommended by the lining manufacturer. The average profile depth using a Keane-Tator comparator, profile depth gage, or other suitable instrument, shall be measured by Test Methods D 4417.

5.3 Apply the lining to the test panels as prescribed by the manufacturer and in a manner as closely simulating field application as possible. For example, if the lining is to be spray applied in the field, the lining for the test panels should be spray applied also. Lining thickness should be within 10 % of the nominal thickness specified.

5.3.1 The opposite (unprepared) side should be left unlined. A very thin (1 to 3 mils, 25 to 76 μm) coating may be applied to the unprepared side, if necessary, to prevent rusting.

5.3.2 Wherever possible, duplicate test panels should be run to determine reproducibility of results.

5.4 *Conditioning of Test Panels*—Condition test panels for a period of 7 days at $73 \pm 4\text{F}^{\circ}$ ($23 \pm 2\text{C}^{\circ}$). Additional conditioning of test panels, including longer cure times or elevated cure temperatures, may be conducted if specified by the lining manufacturer.

5.5 *Specimen Measurements:*

5.45.1 Check the thickness of the lining material by using an appropriate dry-film thickness gage.

5.45.2 Check the discontinuities in the lining material of one-side exposure test panels by using an appropriate electrical holiday detector with a minimum voltage of 100 V/0.001 in. (25.4 μm) of lining thickness. Practice D 5162. Consult the lining manufacturer for the recommended voltage limitation of to be used. Low voltage detectors are not recommended unless specifically recommended by the lining manufacturer.

5.45.2.1 High-voltage holiday detection should not be used on linings that have been exposed. The test could be destructive and

may not be meaningful since the dielectric strength of the lining material may be changed by the exposure.

5.5.2.2 If discontinuities are found, either repair the lining or replace the test panel(s).

NOTE 13—Certain linings are conductive and cannot be tested in this manner.

5.45.3 Visually inspect the lining surface of all panels before the test exposure is begun to determine the color, clarity, surface gloss, and surface texture; also, any gross imperfections such as voids, cracks, runs, or sags.

5.45.4 Determine the hardness of the lining by a suitable standard hardness test such as Test Methods D 785, D 1474, ~~D 2583 Shore, Rockwell, or Bareol~~ methods D 2583, and D 3363 in an area of the panel that will not be exposed to the test solution.

~~5.5 Conditioning of Test Panels—Condition test panels for a period of 7 days at 73 ± 4°F (23 ± 2.2°C). Additional conditioning of test panels, including longer cure times or elevated cure temperatures, solution. Hardness determinations may be conducted if specified by the lining manufacturer. invalid for some aggregate-filled systems.~~

6. Test Solution

~~6.1 Although most lining tests are conducted with pure chemicals, the~~

6.1 The test solution media shall be identical to simulate the anticipated service environment when testing lining materials for a specific application. ~~All~~

~~6.1.1 The concentration(s) of the service environment must chemical(s) shall be present and reported in the results.~~

~~6.1.1 If only the name of the chemical is given to describe the environment, it is understood that the pure chemical name was used in the tests.~~

~~6.1.2 Unless specified. Unless otherwise stated, all dilutions shall be assumed to be with water; thus, 5 % hydrochloric acid shall be assumed to be 5 % by weight of HCl in water. Dilutions shall be made with distilled, demineralized, or deionized water unless otherwise reported. water.~~

6.1.2 If no concentration is specified, it is understood that the chemical is used in its undiluted form.

~~6.2 Analysis of the test solution will may be necessary only performed when the following conditions are known to exist. occur:~~

~~6.2.1 Loss of media or buildup of contaminants and.~~

~~6.2.2 Any change of the test solution.~~

7. Procedure

7.1 Following the conditioning period, clamp the test panels in place at the ends of the test cell with the lining material positioned against the cell interior. Use a suitable gasket material between the lining and cell faces described in 4.4 to ensure against leakage of the test solution.

7.2 The assembled test cell may be filled with tap water and held approximately 1 h to check for complete sealing of the apparatus.

7.3 Fill the test cell $\frac{2}{3}$ to $\frac{3}{4}$ of its total height with the test solution and commence heating, if required. Mark the outer, unexposed panel area, indicating the test solution level for visual control of the test solution level.

7.4 Disassemble the test cell at one month or other intervals for inspection. When the apparatus is reassembled, recharge it with fresh test media. Recharging of the test media may be necessary at more frequent intervals, if required due to the nature of the media, for instance, NaOCl (see Section 6).

7.4.1 When test panels are disassembled from the test cell, rinse the panels with distilled water and wipe dry. No other conditioning is required.

7.5 *Interim Evaluation:*

7.5.1 Make the visual inspection and record the results for the following:

7.5.1.1 *Color*—State any changes noted in the color of the lining.

7.5.1.2 *Surface Gloss*—Report any dulling of the lining surface.

7.5.1.3 *Surface Texture*—Note signs of chemical or physical erosion.

7.5.1.4 Blisters—Inspect the surface for blisters by visual and audible methods such as lightly tapping or applying a straight edge to the surface of the panel. Describe the size, quantity, and location of blisters. Use Test Method D 714 where possible.

7.5.1.5 Changes in the test solution.

7.6 *Final Evaluation:*

7.6.1 After the sixth month of exposure or upon failure, repeat the procedures described in Section 7.5 and conduct the following additional tests:

7.6.1.1 Determine the hardness of the lining as described in 5.45.4 on portions of the panel exposed to: (1) liquid solution, (2) vapor phase, (3) liquid-vapor interface, and (4) unexposed area.

~~7.6.1.2 Determine~~

7.6.1.2 Make an appraisal of the adhesion of the lining to the substrate by. Depending on the knife adhesion test. Because type of the thickness, rigidity, or toughness of certain lining systems, a hammer or chisel lining, this appraisal may be required. This is made using different methods such as strip peeling, elcometer test (Test Method D 4541) or prying with a simple and rapid method knife or similar equipment. Not all of determining qualitatively any change in the adhesion, hardness, embrittlement, etc., of a lining after exposure to a specific environment. The test does not these methods will provide a specific value but does provide

~~a comparison of properties between an exposed panel and the control (unexposed) area of the panel. Run the knife test on the unexposed portion of the panel, on the portion exposed to liquid, and on the portion exposed to the vapor. value. During this destructive evaluation, the location of blisters should be determined. The blisters may be at the surface of the substrate, between layers within the lining system, or within one layer of the lining system.~~

~~7.6.1.3 High-voltage holiday detection should not be used on linings that have been exposed. The test could be destructive and may not be meaningful since the dielectric strength of the lining material may be changed by the exposure.~~

8. Report

8.1 The report shall include the following information concerning the lining system and test conditions:

8.1.1 Manufacturer's name, product designation, and generic type;

~~8.1.2 Method type;~~

8.1.2 Type of test substrate;

~~8.1.3 Method of panel preparation, including the depth of profile and all steps and application procedures used in the construction application of the lining. The initial thickness of the lining shall be measured and recorded;~~

8.1.3 Type of metallic test substrate;

8.1.4 Thickness, hardness, and recorded;

8.1.4 Conditioning procedure;

~~8.1.5 Hardness, visual observations, and note any repairs or any discontinuities. The test method used to determine the lining;~~

8.1.5 Conditioning procedure, hardness shall be noted;

8.1.6 Description of lining appearance prior to testing; and

8.1.7 Test conditions including test media, temperature, ~~term~~ time of exposure, length of intervals between exposures, and frequency of recharging test solutions.

8.2 The results of each interim inspection shall comprise a description of the appearance of the test panel at each inspection, noting any changes in the surface texture, evidence of cracking, blistering, or delamination. Changes in media appearance should be reported. ~~Wherever possible, duplicate test panels should be run to determine reproducibility of results. reported.~~

8.3 Qualitative evaluation of the final inspection shall include ~~continuity~~, an appraisal of adhesion of adhesion of the lining to the substrate, notation of any signs of substrate attack or corrosion such as metal rusting, metal darkening, or any ~~oxides visible~~ visible oxides.

8.3.1 A pictorial study of test panels may also be kept. ~~Pictures shall~~ should be taken before exposure and at each test interval. ~~Two sets of pictures are~~ should be taken at test conclusion; one set before destruction; and one set after destruction.

8.3.2 When a degree of chemical attack is questionable, a microscopic examination may be of value. This is purely a qualitative examination to determine depth of degradation or possible degree of permeation of the lining by the test solution.

9. Precision and Bias

9.1 This test method is as specific as possible in establishing reproducible methods and procedures. Final test result and report, however, depends heavily on visual observations and subjective evaluation and results and conclusions may vary.

9.2 Wherever possible, duplicate test panels should be run to determine reproducibility of results.

10. Keywords

10.1 blistering; cell test; corrosive media; discontinuities; holiday; permeation; profile depth; protective lining; chemical resistance; adhesion; coating

ASTM International takes no position respecting the validity of any patent rights asserted in connection with any item mentioned in this standard. Users of this standard are expressly advised that determination of the validity of any such patent rights, and the risk of infringement of such rights, are entirely their own responsibility.

This standard is subject to revision at any time by the responsible technical committee and must be reviewed every five years and if not revised, either reapproved or withdrawn. Your comments are invited either for revision of this standard or for additional standards and should be addressed to ASTM International Headquarters. Your comments will receive careful consideration at a meeting of the responsible technical committee, which you may attend. If you feel that your comments have not received a fair hearing you should make your views known to the ASTM Committee on Standards, at the address shown below.

This standard is copyrighted by ASTM International, 100 Barr Harbor Drive, PO Box C700, West Conshohocken, PA 19428-2959, United States. Individual reprints (single or multiple copies) of this standard may be obtained by contacting ASTM at the above address or at 610-832-9585 (phone), 610-832-9555 (fax), or service@astm.org (e-mail); or through the ASTM website (www.astm.org).