



Designation: C 947—99 — 03

Standard Test Method for Flexural Properties of Thin-Section Glass-Fiber-Reinforced Concrete (Using Simple Beam With Third-Point Loading)¹

This standard is issued under the fixed designation C 947; the number immediately following the designation indicates the year of original adoption or, in the case of revision, the year of last revision. A number in parentheses indicates the year of last reapproval. A superscript epsilon (ϵ) indicates an editorial change since the last revision or reapproval.

1. Scope

1.1 This test method covers determination of the flexural ultimate strength in bending and the yield strength of glass-fiber reinforced concrete sections by the use of a simple beam of 1.0 in. (25.4 mm) or less in depth using third-point loading.

1.2 The values stated in inch-pound units are to be regarded as the standard. The values given in parentheses are for information only.

1.3 *This standard does not purport to address all of the safety concerns, if any, associated with its use. It is the responsibility of the user of this standard to establish appropriate safety and health practices and determine the applicability of regulatory limitations prior to use.*

2. Referenced Documents

2.1 *ASTM Standards:*

C 1228 Practice for Flexural and Washout Tests on Glass Fiber Reinforced Concrete²

¹ This test method is under the jurisdiction of ASTM Committee C-27 on Precast Concrete Products and is the direct responsibility of Subcommittee C27.40 on Glass Fiber Reinforced Concrete Made by the Spray-Up Process.

Current edition approved Jan. June 10, 1999; 2003. Published June 1999; July 2003. Originally published as C 947-81; approved in 1981. Last previous edition approved in 1999 as C 947 - 979.

D 76 Specification for Tensile Testing Machines for Textiles³
 E 4 Practices for Force Verification of Testing Machines⁴

3. Significance and Use

3.1 Flexural properties determined by this test method are useful for quality control of glass-fiber reinforced concrete products, ascertaining compliance with the governing specifications, research and development, and generating data for use in product design.

4. Apparatus

4.1 *Testing Machine*— A properly calibrated testing machine that can be operated at constant rates of crosshead motion and in which the error in the force measuring system shall not exceed $\pm 1.0\%$ of the maximum force expected to be measured shall be used. The testing machine shall be equipped with a deflection measuring and recording device. The stiffness of the testing machine shall be such that the total elastic deformation of the system does not exceed 1.0 % of the total deflection of the test specimen during the test, or appropriate corrections shall be made. The force-indicating mechanism shall be essentially free of inertial lag at the crosshead rate used. The accuracy of the testing machine shall be verified in accordance with Practices E 4 and Specification D 76.

4.2 *Loading Noses and Supports* —The loading noses and supports shall have cylindrical surfaces. In order to avoid excessive indentation or failure due to stress concentration directly under the loading noses or supports, the radius of the noses and supports shall be at least 0.25 in. (6.35 mm). See Fig. 1 for loading configuration. The arc of the loading noses and supports, in contact with the specimen, shall be sufficiently large to prevent contact of the specimen with the sides of the noses. Neoprene pads, approximately 1/16 in. (1.6 mm) thick, may be placed between the loading noses and the test specimen for uniform load distribution across the width of the specimen. However, neoprene pads should not be used if deflection measurements are to be made, as the compression of the neoprene will distort the measurements.

4.3 *Loading Head and Support Apparatus* —Loading noses, supports, and their respective holding devices shall be designed to allow rotation to occur about axes that lie in horizontal planes of the loading apparatus as shown in Fig. 1. This configuration of loading head and support apparatus will ensure that forces applied to the specimen will be initially perpendicular to the surfaces of the specimen and applied without eccentricity.

4.4 *Specimen Depth and Width Measuring Device*—A caliper or micrometer or other suitable device that is able to measure sample depth accurate to 0.005 in. (0.13 mm) and width accurate to 0.01 in. (0.25 mm).

5. Sampling

5.1 Test boards shall be manufactured in accordance with governing specifications.

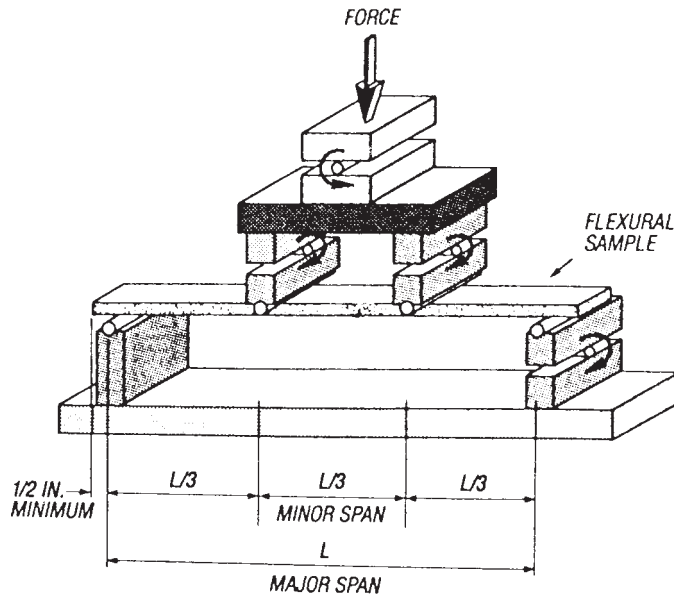

FIG. 1 Loading Configuration for Flexural Testing

² Annual Book of ASTM Standards, Vol 04.05.
³ Annual Book of ASTM Standards, Vol 07.01.
⁴ Annual Book of ASTM Standards, Vol 03.01.

6. Test Specimen

6.1 Six test specimens shall be prepared in accordance with Practice C 1228.

6.2 The test specimen shall have a ratio of the specimen major span length to the specimen depth between 16 to 1 and 30 to 1. The total specimen length shall be a minimum of 1 in. (25 mm) longer than the specimen's major span. Nominal specimen width shall be 2 in. (50 mm).

7. Conditioning

7.1 The sample or specimens shall be transported to the testing laboratory packaged so that no damage will take place.

7.2 Condition the samples or specimens in water at $73 \pm 5^\circ\text{F}$ ($23 \pm 3^\circ\text{C}$) for a period of ~~34 ± 14~~ minimum 24 h and maximum 72 h to ensure complete saturation and test immediately upon removal. Remove specimens from water bath individually and test. Do not allow specimen surfaces to dry out either prior to or during the test. Specimen surfaces may be sprayed with water during testing if indications of surface drying are present.

7.3 Samples or specimens shall be tested in a temperature controlled environment at $73 \pm 5^\circ\text{F}$ ($23 \pm 3^\circ\text{C}$).

8. Procedure

8.1 Set the major span of the test apparatus to correspond with 6.2.

8.2 Set the minor span to correspond with one third of the major span.

8.3 Align the loading noses and supports so that the axes of the cylindrical surfaces are parallel.

NOTE 1—The parallelism of the loading noses and supports may be checked by means of a plate containing parallel grooves into which the loading noses and supports will fit when properly aligned.

8.4 Center the specimen on the supports with equal lengths of specimen projecting outside of the supports with the long axis of the specimen perpendicular to the loading noses and supports.

8.5 Test three specimens with the mold face in tension and three specimens with the opposite face (or trowelled face) in tension.

8.6 Set the crosshead speed of the testing machine at 0.05 to 0.20 in./min (1.27 to 5.1 mm/min). Set the chart speed to 75 ± 25 times the crosshead speed being used. Set the initial load measuring range such that the flexural yield strength (F_y) load occurs at not less than 30 % of full scale. Apply force at a constant crosshead speed to specimen failure. Examine the failure location of the specimen. If failure occurs outside the minor span, discard the specimen and specimen test data.

NOTE 2—The chart speed may be reduced or stopped after the force-deflection curve reaches its point of deviation from linearity (P_y in Fig. 2) to conserve chart paper.

8.7 Record the maximum force attained (P_u) and the force where the force-deflection curve deviates from linearity (P_y). Also the deflections should be measured at the point where the force-deflection curve deviates from linearity (Y_y) and at failure (Y_u). See Fig. 2 for a typical force-deflection chart recording.

8.8 Determine and record the average of three specimen depth measurements to the nearest 0.005 in. (0.125 mm) at or near the fracture location. Determine the specimen width to the nearest 0.01 in. (0.25 mm) at or near the failure location. Use a measuring device as described in 4.4.

NOTE 3—Observe caution to avoid measurements at locations that have been expanded at or near the fracture.

9. Calculations

9.1 Calculate flexural yield strength (F_y) as follows:

$$F_y = P_y L / bd^2 \quad (1)$$

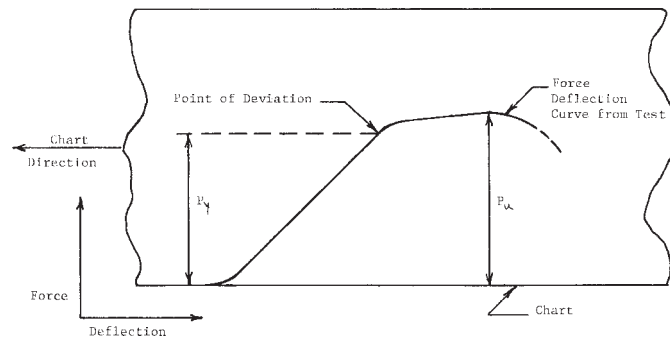

FIG. 2 Force Deflection Chart

where:

- F_y = flexural yield strength psi (or MPa),
- P_y = force at the point on the force-deflection curve where the curve deviates from linearity, lbf (or N),
- L = major support span, in. (or mm),
- b = width of specimen, in. (or mm), and
- d = depth of specimen, in. (or mm).

9.2 Use of testing machines with magnification factors (ratio of chart speed to crosshead speed) of less than 50:1 may lead to systematic errors in identifying the point at which the force-deflection curve deviates from linearity. Such errors may be corrected by the use of a factor determined by comparing results from specimens from a variety of specimens yielding a range of proportional elastic limit values tested on machines with and without the recommended magnification factors.

9.3 Calculate the flexural ultimate strength (F_u) as follows:

$$F_u = P_u L / bd^2 \quad (2)$$

where:

- F_u = flexural ultimate strength, psi (or MPa),
- P_u = maximum force achieved by the specimen, lbf (or N),
- L = major support span, in. (or mm),
- b = width of specimen, in. (or mm), and
- d = depth of specimen, in. (or mm).

10. Report

10.1 Report the following information:

- 10.1.1 Identification number of specimen,
- 10.1.2 Sample description and age,
- 10.1.3 Sample conditioning,
- 10.1.4 Date of testing,
- 10.1.5 Crosshead speed,
- 10.1.6 Chart speed,
- 10.1.7 Major span,
- 10.1.8 Specimen depth to nearest 0.005 in. (0.127 mm) and width to nearest 0.01 in. (0.254 mm), and
- 10.1.9 Deflections at the point where the force-deflection curve deviates from linearity and at failure.
- 10.1.10 Test Results:
 - 10.1.910.1 Flexural yield strength to the nearest 5 psi (0.03 MPa), and
 - 10.1.910.2 Flexural ultimate strength to the nearest 5 psi (0.03 MPa).

11. Precision and Bias

11.1 The precision and bias criteria are being developed and tests are being run.

12. Keywords

12.1 flexural properties; GFRC; glassfiber reinforced concrete

APPENDIX

(Nonmandatory Information)

X1.

X1.1 In certain circumstances a value for the Modulus of Elasticity is required. This can be calculated as follows:

$$E = \frac{5P_y L^3}{27Y_y b d^3} \quad (X1.1)$$

where:

- E = initial flexural modulus of elasticity, psi (Mpa),
- Y_y = deflection at the point where the load-deflection curve deviates from linearity,
- P_y = force at the point on the force-deflection curve where the curve deviates from linearity, lbf (or N),
- L = major support span, in. (or mm),
- b = width of specimen, in. (or mm), and

d = depth of specimen, in. (or mm).

NOTE X1.1—If a deflectionometer is used at the center of the major span to measure specimen deflection in order to minimize the effects of machine and fixture stiffness, the flexural modulus of elasticity is then calculated using the following equation:

$$E = \frac{23P_y L^3}{108Y_b d^3} \quad (X1.2)$$

ASTM International takes no position respecting the validity of any patent rights asserted in connection with any item mentioned in this standard. Users of this standard are expressly advised that determination of the validity of any such patent rights, and the risk of infringement of such rights, are entirely their own responsibility.

This standard is subject to revision at any time by the responsible technical committee and must be reviewed every five years and if not revised, either reapproved or withdrawn. Your comments are invited either for revision of this standard or for additional standards and should be addressed to ASTM International Headquarters. Your comments will receive careful consideration at a meeting of the responsible technical committee, which you may attend. If you feel that your comments have not received a fair hearing you should make your views known to the ASTM Committee on Standards, at the address shown below.

This standard is copyrighted by ASTM International, 100 Barr Harbor Drive, PO Box C700, West Conshohocken, PA 19428-2959, United States. Individual reprints (single or multiple copies) of this standard may be obtained by contacting ASTM at the above address or at 610-832-9585 (phone), 610-832-9555 (fax), or service@astm.org (e-mail); or through the ASTM website (www.astm.org).