



## Standard Terminology for Asbestos and Asbestos–Cement Products<sup>1</sup>

This standard is issued under the fixed designation D 2946; the number immediately following the designation indicates the year of original adoption or, in the case of revision, the year of last revision. A number in parentheses indicates the year of last reapproval. A superscript epsilon ( $\epsilon$ ) indicates an editorial change since the last revision or reapproval.

### 1. Scope

1.1 This terminology covers terms and definitions, definitions of terms, and abbreviations of terms relating to asbestos and asbestos–cement products.

### 2. Referenced Documents

#### 2.1 *ASTM Standards:*

- C 150 Specification for Portland Cement<sup>2</sup>
- C 296 Specification for Asbestos-Cement Pressure Pipe<sup>2</sup>
- C 428 Specification for Asbestos-Cement Nonpressure Sewer Pipe<sup>2</sup>
- C 458 Test Method for Organic Fiber Content of Asbestos-Cement Products<sup>2</sup>
- C 500 Test Methods for Asbestos-Cement Pipe<sup>2</sup>
- C 508 Specification for Asbestos-Cement Underdrain Pipe<sup>2</sup>
- C 541 Specification for Linings for Asbestos-Cement Pipe<sup>2</sup>
- C 618 Specification for Coal Fly Ash and Raw or Calcined Natural Pozzolan for Use as a Mineral Admixture in Concrete<sup>3</sup>
- C 663 Specification for Asbestos-Cement Storm Drain Pipe<sup>2</sup>
- C 668 Specification for Asbestos-Cement Transmission Pipe<sup>2</sup>
- C 875 Specification for Asbestos-Cement Conduit<sup>2</sup>
- C 966 Guide for Installing Asbestos-Cement Nonpressure Sewer Pipe Lines<sup>2</sup>
- D 123 Terminology Relating to Textiles<sup>4</sup>
- D 1067 Test Methods for Acidity or Alkalinity of Water<sup>5</sup>
- D 1118 Test Method for Magnetic Rating of Asbestos Fibers and Asbestos Textiles<sup>6</sup>
- D 1126 Test Method for Hardness in Water<sup>5</sup>
- D 1918 Test Method for Asbestos Content of Asbestos Materials<sup>2</sup>

<sup>1</sup> This terminology is under the jurisdiction of ASTM Committee C-17 on Fiber-Cement Products and is the direct responsibility of Subcommittee C17.91 on Editorial and Terminology.

Current edition approved Sept. 10, 1998. Published March 1999. Originally published as D 2946 – 71 T. Last previous edition D 2946 – 91.

<sup>2</sup> *Annual Book of ASTM Standards*, Vol 04.05.

<sup>3</sup> *Annual Book of ASTM Standards*, Vol 04.05.

<sup>4</sup> *Annual Book of ASTM Standards*, Vol 07.01.

<sup>5</sup> *Annual Book of ASTM Standards*, Vol 11.01.

<sup>6</sup> Discontinued—See 1989 *Annual Book of ASTM Standards*, Vol 07.02.

D 2589 Test Method for McNett Wet Classification of Asbestos Fiber<sup>2</sup>

D 2590 Test Method of Sampling Chrysotile Asbestos Fiber for Testing<sup>2</sup>

D 2985 Test Method for Color of Asbestos<sup>2</sup>

D 3879 Test Method for Sampling Amphibole Asbestos<sup>2</sup>

E 308 Test Method for Computing the Colors of Objects by Using the CIE System<sup>7</sup>

E 849 Practice for Safety and Health Requirements Relating to Occupational Exposure to Asbestos<sup>8</sup>

### 3. Terminology

**accessible bag**, *n—in sampling*, a bag (in a pile of bags of asbestos fiber) of which at least one side or one end is fully exposed.

**accessible surface**, *n—in sampling*, in a pile of bags of asbestos fiber, a side (of the pile) in which all the bags are accessible bags.

**accessories**—subordinate material such as fasteners, backer strips, closure strips, ridge and corner rolls, roofing starters and finishing pieces, couplings, gaskets, pipe fittings or other supplementary material necessary for the proper application of primary asbestos-cement products.

**actinolite asbestos**—asbestiform variety of the monoclinic amphibole silicate minerals of the tremolite-actinolite series. Its empirical formula is  $\text{Ca}_2(\text{Mg}, \text{Fe}^{+2})_5\text{Si}_8\text{O}_{22}(\text{OH})_2$ . Its Chemical Abstracts<sup>9</sup> number is 77536-66-4 (see Table 1 and Table 2).

**adhesion**, *n—in asbestos*, see **fiber adhesion**.

**aggressivity index**, *n*—measure of the corrosiveness of water toward asbestos-cement defined as:

$$\text{pH} + \log (AH) \quad (1)$$

where:

pH = negative of the logarithm of the hydronium molarity (index of acidity of the water) pH units.

A = total alkalinity, ppm as  $\text{CaCO}_3$ , as determined by Test Methods D 1067, and

<sup>7</sup> *Annual Book of ASTM Standards*, Vol 06.01.

<sup>8</sup> Discontinued. See 1994 *Book of ASTM Standards*, Vol 11.03.

<sup>9</sup> Taken from Practice E 849.

*H* = calcium hardness, ppm as CaCO<sub>3</sub>, as determined by Test Method D 1126.

DISCUSSION—The aggressiveness of water toward asbestos-cement is classified as follows:

	Aggressivity Index
highly aggressive	<10
moderately aggressive	10 to 11.9
nonaggressive	≥12

**American method**—method of application for roofing shingles, generally rectangular in shape, to provide double coverage with head lap and no side lap.

**amosite, *n***—the acronym assigned to **grunerite asbestos**, and derived from the name of the first developers of a major deposit of this mineral. See Table 1 and Table 2.

**amphibole asbestos, *n***—asbestiform amphibole silicate minerals including the orthorhombic anthophyllite series and the monoclinic cummingtonite [grunerite asbestos (amosite)] series, the tremolite-actinolite series, and the alkali amphibole [riebeckite asbestos (crocidolite)] series, among others. The amphiboles contain essential (OH) groups in the structure, and the Si:O ratio is 4:11. A considerable amount of elemental substitution can take place in these varieties of asbestos. The crystal structures are composed of strips or ribbons of linked polyhedra that join to form fibrils. The individual strips are made up from three components; these are two double chains of linked (Si, Al)O<sub>4</sub> tetrahedra and a strip of linked MgO<sub>6</sub>, FeO<sub>6</sub>, or AlO<sub>6</sub> octahedra. (See Table 1 and Table 2.)

**anthophyllite asbestos, *n***—asbestiform variety of the orthorhombic amphibole silicate minerals of the anthophyllite series. Its empirical formula is Mg<sub>7</sub>Si<sub>8</sub>O<sub>22</sub>(OH)<sub>2</sub>. Its Chemical Abstracts number<sup>9</sup> is 77536-67-5 (see Table 1 and Table 2).

**asbestiform**—having an inherent fine-textured morphology, resulting from unequal relative development of the principal crystal axes in a silicate mineral, that predetermines subdivision into strong flexible fibers having microscopic to submicroscopic thickness and a high length to width ratio when the mineral is subjected to comminution. Term derived from “asbestos.”

**asbestos, *n***—the generic term for naturally occurring inorganic hydrated silicates, occurring in layered structures composed of chains of silicon and oxygen tetrahedra, that can subdivide into flexible fibers. Refer to STP 834<sup>10</sup>, also, see Table 1 and Table 2.

**asbestos fiber, *n***—acicular silicate mineral, with a structure based upon silicon-oxygen tetrahedra, that fits the definition of a fiber, and is composed of single crystals in predominantly parallel orientation. Common usage also designates a collectivity of asbestos fibers as asbestos fiber.

**asphalt felt, breather type**—underlayment sheet material saturated with asphalt for use with asbestos-cement products, which allows the transmission of water vapor.

**autoclaved products, *n***—in *asbestos-cement*, those that have been treated in a saturated steam atmosphere at between 689

<sup>10</sup> Definitions for Asbestos and Other Health-Related Silicates, ASTM STP 834, 1982.

TABLE 1 Asbestos Minerals, Characterized by their Mineralogy<sup>A</sup>

Designation of Mineral	Type of Asbestos	Chemical Abstracts Number <sup>A</sup>
Serpentine	Chrysotile	12001-29-5
Reibeckite (glaucophane)	Crocidolite (blue asbestos)	12001-28-4
Grunerite (cummingtonite-grunerite)	Amosite (grunerite asbestos)	12172-73-5
Anthophyllite (Gederite)	Anthophyllite	77536-67-5
Tremolite	Tremolite	
(Ferroactinolite)	Asbestos	77536-68-6
Tremolite-actinolite	Actinolite asbestos	77536-66-4

<sup>A</sup> Taken from Practice E 849.

TABLE 2 Chemical Formula for Typical Asbestos Structures

Mineral	Chemical Formula <sup>A</sup>
Chrysotile	Mg <sub>3</sub> (Si <sub>2</sub> O <sub>5</sub> )(OH) <sub>4</sub>
Amosite	(Mg,Fe) <sub>6</sub> (Si <sub>8</sub> O <sub>22</sub> )(OH) <sub>2</sub>
Crocidolite	Na <sub>2</sub> Fe <sub>3</sub> <sup>2+</sup> + (Si <sub>8</sub> O <sub>22</sub> )(OH) <sub>2</sub> (Mg,Fe)
Anthophyllite	Mg <sub>7</sub> (Si <sub>8</sub> O <sub>22</sub> )(OH) <sub>2</sub> (Fe > Mg)
Cummingtonite	(Mg,Fe) <sub>7</sub> (Si <sub>8</sub> O <sub>22</sub> )(OH) <sub>2</sub>
Tremolite	Ca <sub>2</sub> Mg <sub>5</sub> (Si <sub>8</sub> O <sub>22</sub> )(OH) <sub>2</sub>
Ferroactinolite	Ca <sub>2</sub> Fe <sub>5</sub> (Si <sub>8</sub> O <sub>22</sub> )(OH) <sub>2</sub>
Actinolite	Ca <sub>2</sub> (Mg,Fe <sup>2+</sup> ) <sub>5</sub> (Si <sub>8</sub> O <sub>22</sub> )(OH) <sub>2</sub>
Glaucoaphane	NaMg <sub>3</sub> Al <sub>2</sub> (Si <sub>8</sub> O <sub>22</sub> )(OH) <sub>2</sub>

<sup>A</sup> Taken from Deer, Howie, and Zussman, *Rock Forming Minerals*, Vol. 3, Longmans, London, 1967.

and 1517 MPa (100 and 200 psi) for at least 8 h, and that contain portland cement as defined in Specifications C 150 and C 618, together with silica in the ratio of 3:2, that can react to form calcium silicate reaction products.

**backer strips**—water-repellent strips of asphalt-coated felt applied behind each joint where the vertical edges of two shingles meet.

**bag, *n***—in *sampling*, any quantity of asbestos fiber corresponding to one particular grade that is packed in a suitable container.

DISCUSSION—In the asbestos industry, the typical quantity contained in a bag is 45 kg (approximately 100 lb).

**batten**—long narrow strip of asbestos-cement, either flat or corrugated, used to conceal the joints in butt joint application of flat or corrugated sheets.

**black, *adj***—color description applied to opaque objects that are highly light absorbing throughout the visible spectrum.

**bloom, *n***—in *asbestos-cement*, see **efflorescence (bloom)**.

**bundle**—an assemblage of asbestos in which the fibers remain entirely in their original close-packed parallel configuration (or not appreciably displaced therefrom) and having a transverse dimension typically between 2 and 8 mm (see Table 3).

**caulking**—material ranging in physical characteristics from plastic, to solid, to preformed, used to seal and waterproof joints and overlaps in structures, other assemblies or portions thereof where movement may occur.

**cement, portland**—hydraulic cement produced by pulverizing clinker consisting essentially of hydraulic calcium silicates, and usually containing one or more of the forms of calcium sulfate as an interground addition and conforming to Specification C 150.

**cement, portland blast-furnace slag**—essentially an intimately interground mixture of portland cement clinker and

**TABLE 3 Relative Dimensions of Naturally Occurring Chrysotile Agglomerates in Increasing Order of Transverse Dimension**

Order	Name	Approximate Transverse Dimension	
		min	max
1	Fibril	0.0 $\mu\text{m}$	0.1 $\mu\text{m}$
2	Fiber (single)	0.015 $\mu\text{m}$	0.1 $\mu\text{m}$
3	Spicule	...	...
4	Nonfibrous spicule	...	...
4	Fiber spicule	...	1 mm
5	Pencil	1 mm	8 mm
5	Spelk	1 mm	8 mm
6	Bundle	8 mm	...
6	Crudy bundle	8 mm	...

granulated blast-furnace slag or an intimate and uniform blend of portland cement and fine granulated blast-furnace slag in which the amount of the slag constituent is within specified limits conforming to Specification C 150.

**cement, portland pozzolan**—intimate and uniform blend of portland cement or portland blast-furnace slag cement and fine pozzolan produced by intergrinding portland cement and pozzolan, by blending portland cement or portland blast-furnace slag cement and finely divided pozzolan, or a combination of intergrinding and blending, in which the amount of the pozzolan constituent is within specified limits.

**chemical resistance**—*in asbestos cement products*, the ability of the product to resist chemical attack, dissolution, decomposition or other chemical changes when in contact with liquid, gaseous, or solid media normally encountered in its service environment.

**chrysotile**, *n*—an asbestos mineral belonging to the serpentine group, having a chemical composition close to  $\text{Mg}_3\text{SiO}_5(\text{OH})_4$ . Moderate amounts of aluminum may substitute for silicon and moderate amounts of iron may substitute for magnesium. Small amounts of  $\text{MnO}$ ,  $\text{CaO}$ ,  $\text{K}_2\text{O}$ , and  $\text{Na}_2\text{O}$  are also reported in the chemical analyses. The crystal structure of chrysotile asbestos consists of double layers, each consisting of a layer of linked  $\text{SiO}_4$  tetrahedra that is coordinated to a second layer of linked  $\text{MgO}_2(\text{OH})_4$  octahedra linked through the sharing of oxygen atoms; the composite double layer rolls up, like a scroll to form long hollow tubes. The outer diameters of the individual tubes are in the order of 25 nm; the length-to-diameter ratio can vary from 20 to well over 10 000. Chrysotile is characterized by a combination of a distinctive morphology, a chemical composition close to  $\text{Mg}_3\text{Si}_2\text{O}_5(\text{OH})_4$ , and characteristic X-ray and electron diffraction patterns. Its Chemical Abstracts number<sup>9</sup> is 12001-29-5 (see Table 1 and Table 2).

**chrysotile asbestos**—see **chrysotile**.

**CIE**, *n*—abbreviation for International Commission on Illumination, which in French is Commission Internationale de l'Éclairage.<sup>11</sup>

**CIE observer**, *n*—*in color determination*, see **observer, standard, CIE 1931**; and **observer, supplementary, CIE 1964**.

**CIE source C**, *n*—see **standard source**.

**clip**, *n*—*in shingles*, see **storm anchor (clip)**.

**closure strip**—asphalt or rubber preformed filler strip having the same shape and pitch as the asbestos-cement corrugated product and used to close openings in the corrugated sheets at window beads, eaves, lower edge of siding, and similar places.

**cohesion**, *n*—*in asbestos*, lateral force resisting separation of adjacent fibrous elements.

DISCUSSION—Asbestos may be described as having low to high cohesion.

**color, psychophysical**, *n*—characteristics of a color stimulus (that is, light producing a visible sensation that is a function of its wave length) denoted by three dimension values such as three tristimulus<sup>12</sup> values.

**color variation**—property of nonuniform color exhibited by asbestos-cement products before or after weathering.

**compacted backfill**, *n*—*in pipe laying*, backfill material that has been compacted to the density specified by the engineer.

**composite sample**, *n*—*in asbestos*, a set of unit samples of asbestos fiber (drawn systematically or at random) taken from a lot, comprising not less than two and not more than 200 bags, for use in the laboratory as a test sample, that is, as a source of test specimens.

**conditioning**, *n*—*in sampling*, the process by which the fiber is put into a consistent state to be tested.

**conduit**, *n*—*in asbestos-cement*, asbestos-cement pipe used to protect wires for electric-power or communication systems, for both underground and exposed situations.

**constructor**, *n*—*in pipe laying*, party that furnishes the work and materials for placement and installation.

**contaminants**, *n*—*in asbestos*, any foreign matter (other than associated minerals and fines) in a sample of asbestos fiber.

**corner rolls**—half-round units of asbestos cement used to trim and flash corners in asbestos-cement corrugated applications.

**corrugated**—denotes an asbestos-cement sheet product having a design of alternating ridges and valleys manufactured according to a specified pitch.

**coupling**, *n*—*in asbestos-cement conduit, sewer, underdrain, and storm drain pipe*, component made from a larger diameter pipe of the same type or type II and of the same class, or of a higher class, or produced otherwise to yield at least equal performance, for joining asbestos-cement pipe that when properly installed, forms a silt-tight joint, allows alignment corrections and slight changes in direction, and provides an assembled joint equivalent in serviceability and strength to the pipe sections. Alternatively, for storm drain couplings, plastic sleeves that, when properly installed develop sufficient tightness to prevent the surrounding soil from entering the drain, may be used as couplings.

**coupling**, *n*—*in asbestos-cement nonpressure sewer pipe*, section for joining asbestos-cement nonpressure sewer pipe, that when properly installed with the proper accessories, develops an assemble joint equivalent in serviceability and

<sup>11</sup> Commission Internationale de l'Éclairage (International Commission on Illumination). The CIE color-order system is the most important of those used in connection with instruments for color measurement. See Test Method E 308.

<sup>12</sup> Tristimulus filters are described in Lih, M. M., "Color Technology," *Chemical Engineering*, Vol 75, No. 17, Aug. 12, 1968, pp. 146–156.

strength to the pipe sections when tested in accordance with 8.3 of Specification C 428.

**coupling**, *n*—*in asbestos-cement pressure pipe*, section for joining asbestos-cement pipe that, when properly installed with the proper accessories, develops a joint equivalent in strength and serviceability to the pipe sections.

**crenulations**—multiple kinks that can increase the apparent fiber cohesion.

DISCUSSION—Asbestos may be described as free of crenulations or as highly crenulated.

**crocidolite**, *n*—common name for **riebeckite asbestos**. Also known as blue asbestos (see Table 1 and Table 2).

**cross-fiber**—asbestos that is located in (or derives from) veins or seams in which the fibers are close-packed and are oriented at a large angle to the boundaries of the veins or seams.

**crude asbestos**—hand-cobbed (released from its ore by manual hammer impact) cross-vein asbestos in its natural or unfiberized form.

**crudiness (kroodiness)**—the extent to which a sample of asbestos contains crudy elements. See **crudy**.

**crudy (kroodi)**—the quality of processed asbestos with relatively low specific surface area and degree of fiberization, containing an appreciable portion of intact assemblages of fiber (derived from the term crude asbestos).

**crudy (kroodi) bundle**—a heavy assemblage of asbestos in closed-packed parallel orientation, that may be partially crushed, and that has a transverse dimension exceeding 8 mm.

**crushing strength**—property of solid material that indicates its ability to withstand collapse from external compressive loads.

**cure**—reaction mechanism in which the physical, chemical, and mechanical properties of a hydraulic cement change through the phases of slurry-paste-solid with time, with or without external heat, in the presence of water.

**cure, autoclave**—means for accelerating the cure reaction at elevated temperature and pressure in saturated steam, where reactive siliceous material has been incorporated into the cementitious matrix, such that a hydrothermal reaction takes place between the cement and silica yielding calcium silicate.

**cure, immersed**—the method of setting or hardening asbestos-cement products by immersion in water or in an aqueous solution, resulting in modified chemical activity between the cementitious components with an increase or decrease in the rate of cure.

**cure, normal cure**—method of setting or hardening asbestos-cement products wherein the hydraulic cement is allowed to hydrate at atmospheric conditions of pressure, preferably under conditions to inhibit water loss.

**curing agent**—additive incorporated in the furnish of asbestos-cement products resulting in modified chemical activity between the cementitious components with an increase or decrease in the rate of cure.

**daylight 0.785 rad, 0 rad (45°, 0°) luminous directional reflectance**, *n*—daylight 0.785 rad, 0 rad (45°, 0°) luminous directional reflectance (for brevity called reflectance) is the

ratio of the luminous flux from a specimen illuminated at an angle of 0.785 rad (45°) by CIE Standard Source C<sup>11</sup> (average daylight) and viewed perpendicularly by the CIE Standard Observer, to the luminous flux from the standard magnesium oxide layer, similarly illuminated and viewed (see Discussion). The combination of illumination at 0.785 rad (45°) and viewing at 0 rad (0°) (perpendicularly) has been selected as being representative of average conditions of illuminating and viewing. The property of reflectance determines which of two specimens will appear lighter when viewed in average daylight at an angle at which the observation of highlights is avoided.

DISCUSSION—These conditions of illumination and observation may be interchanged without affecting the results.

**deflection**—linear distance that a test specimen bends at the center from no load to stated load when loaded as a beam.

**density**—mass per unit volume, usually expressed in g/cm<sup>3</sup> or lb/ft<sup>3</sup>.

**drawings**, *n*—*in pipe laying*, illustrations (such as drawings, sketches, graphs, or photographs) on paper, film, diskettes, magnetic tape or other media, blueprints, layouts, designs, figures, portrayals, pictures, charts, maps, images, patterns, diagrams, representations, and plans supplied by the purchaser to show the location and details for the construction of the pipeline and appurtenances.

**Dutch or Scotch method**—method of application for asbestos-cement roofing shingles which are rectangular in shape and lap at the top and one side to form either a square or rectangular pattern.

**efflorescence (bloom)**—white powdery substance occurring on the surface of asbestos-cement products and caused by the migration of soluble salts, followed by precipitation and atmospheric carbonation of calcium hydroxide, to the surface followed by an atmospheric carbonation.

**engineer**, *n*—*in pipe laying*, the person, firm, corporation, or government agency acting for the owner as his duly authorized agent in the designing and engineering of the project.

**fiber**, *n*—any material in a form such that it has a minimum length to average maximum transverse dimension of 10 to 1, a maximum cross-sectional area of  $5.06 \times 10^{-2}$  mm<sup>2</sup> (corresponding to a circular cross section of 0.254 mm in diameter) and a maximum transverse dimension of 0.254 mm.

**fiber adhesion**, *n*—*in asbestos*, force required to overcome the tendency of fibers to remain affixed to the host rock.

DISCUSSION—Fibers may be described as having from low to high adhesion.

**fiber cohesion**, *n*—*in asbestos*, force required to separate fibers from each other.

DISCUSSION—Fibers may be described as having from low to high cohesion.

**fiber spicule**—rod-like piece composed of asbestos fibers that are in close-packed parallel orientation, undisturbed from their natural relative positions, and sufficiently numerous to render the piece inflexible. If the transverse dimension exceeds 1 mm the term “pencil” may be applied.

**fiber strength unit**—see **strength unit**.

**fibril**, *n*—*in asbestos*, fiber composed of a single crystal. The smallest structural component of an asbestiform mineral (see Table 3).

**fibrous**, *adj*—*in asbestos*, pertaining to fine acicular (needle-like), flexible crystalline morphology associated with the subdivision of macro-assemblages of an asbestiform mineral.

**fibrous particulate**, *n*— *in asbestos*, fiber, fiber fragment, or fiber agglomerate.

**filler**—inert inorganic material used as an extender or diluent in the furnish of asbestos-cement which does not add to the cementitious value of the cement.

**finest**, *n*—*in asbestos*, the class of material having the smallest range of particle size, that is segregated by a particle size classification of asbestos by any relevant test method. Customarily, the fraction that passes through the finest aperture screen used in Test Method D 2589.

**fitting**, *n*—*for conduit*, component such as adaptors, reducers, increasers, bends, and bell ends, for use in laying asbestos-cement conduit and made of equivalent strength and to such dimensions as will provide silt-tight joints when assembled with the conduit.

**fitting**, *n*—*for pipes*, components such as wyes, tees, elbows, and adaptors for use in laying asbestos-cement pipe, such that, when properly installed, yield as an assembly equivalent inserviceability and strength to the pipe sections.

**flat sheets, Type F (flexible)**—asbestos-cement flat sheet suitable for exterior or interior use, where a board having higher strength and density, smoother surface, greater flexibility, and lower moisture absorption is desired.

**flat sheets, Type U (utility)**—asbestos-cement flat sheet suitable for exterior or interior use, having sufficient strength for general utility and construction purposes, and where a board having maximum flexibility, highest density, smoother surface, and lower moisture absorption is not essential.

**flexural strength**, *n*—*in asbestos-cement bulkheading*, the transverse breaking load in newtons per metre of width (lbf/ft of width) of saturated sheets when loaded on a span of 1.524 m (5 ft) with the load applied equally and simultaneously at both one-third points of the span.

**flexural strength**, *n*—*in asbestos-cement plastic-foam core insulating panels*, the average breaking load in newtons (or lbf) of specimens conditioned seven days at  $23 \pm 2^\circ\text{C}$  and  $50 \pm 10\%$  relative humidity, loaded as simple beams with the load applied equally and simultaneously at both one-third points of the span.

**flexural strength**, *n*—*in corrugated asbestos-cement sheets*, the average breaking load in newtons per metre of width (or lbf/ft of width) of dried specimens loaded as simple beams on a 762 mm (30 in.) span with the load applied equally and simultaneously at both one-third points of the span.

DISCUSSION—The flexural performance is defined as the moment capacity in N m/m (or ft lbf/ft) of width obtained from the product of flexural strength and span divided by six.

**flexural strength**, *n*—*in flat asbestos-cement sheet*, the average breaking load in newtons (or lbf) of dried specimens loaded as simple beams on a span of 254 mm (10 in.) with the load applied equally and simultaneously at both one-

third points of the span.

**flexural strength**, *n*—*in pipe*, the ability of a standard pipe longitudinal section to withstand external loads that bear on the pipe transversely to its longitudinal axis and induce bending.

**flexural strength**, *n*—*in plastic foam core asbestos-cement insulating panels*, see **flexural strength**, *in asbestos-cement plastic-foam core insulating panels*.

**flexural strength**, *n*—property of solid material that indicates its ability to withstand a flexural or transverse bending load.

**floats** (as in asbestos floats)—air conveyed asbestos fractions such as accumulate in the air filtration system of an asbestos mill.

**fracture** (as in fractured asbestos)—a clearly defined transverse break in the asbestos in situ.

**free lime**, *n*—*in asbestos-cement*, uncombined calcium hydroxide.

**French or hexagonal method**—a method of application for asbestos-cement roofing, whereby the shingles have at least three corners clipped so that when they are laid with their diagonals perpendicular to the eaves of the roof, they lap at the top and sides to form a hexagonal pattern.

**gloss**, *n*—angular selectivity of reflectance of surface-reflected light responsible for the degree to which reflected highlights or images of objects may be seen as superimposed on a surface.

**gloss, specular**, *n*—ratio of flux reflected in a specular direction to incident flux for specific source and receptor apertures (usually measured relative to a standard of specified index of refraction).

**grade**, *n*—*in asbestos*, asbestos fiber that has the same chemical, physical, and mechanical properties and which is designated by a particular code corresponding to any given specifications.

**granules**—small ceramic or natural colored mineral pellets or grains applied to asbestos-cement to lend color to the surface.

**green**, *adj*—hue description applied to light of wavelengths from 495 to 550 nm and to visually similar stimuli.

**grey**, *adj*—color description applied to achromatic stimuli of moderate relative luminance.

**grunerite asbestos**, *n*—a member of the mineral group of monoclinic amphiboles derived from grunerite or cummingtonite-grunerite. Its representative chemical formula is approximately  $(\text{Mg,Fe})_6(\text{Si}_8\text{O}_{22})(\text{OH})_2$ . Its Chemical Abstracts<sup>9</sup> number is 12172-73-5 (see Table 1 and Table 2).

**handful**, *n*—*in sampling*, as much fiber as the hand can contain.

**harsh** (as in harsh asbestos)—description for asbestos with relatively high harshness.

**harshness**—apparent property of asbestos that exhibits a significant degree of stiffness or rigidity.

**headlap**—the shortest distance between the lower edge of an overlapping shingle or sheet and the upper edge of the lapped unit in the second course below (see Fig. 1).

**hip and ridge, finishing pieces**—rectangular pieces of roofing shingles cut to a flare or taper and applied with a side lap to

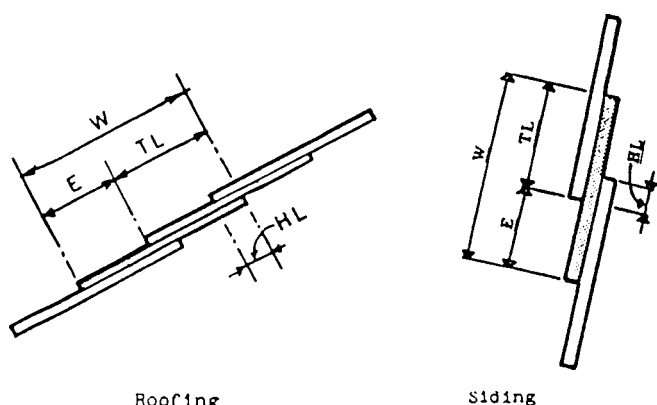

Roofing

Siding

Terminology  
 E—Exposure  
 TL—Toplap  
 HL—Headlap  
 W—Width for strip shingles or length for individual shingles

FIG. 1 Examples of Overlap

conceal the joint of roofing shingles along the hips and ridge of a roof.

**hue, n**—attribute of color perception by means of which objects are judged to be red, yellow, blue, or intermediate between some adjacent pair of these.

*hydrostatic pressure*—see **hydrostatic strength**.

**hydrostatic strength**—the ability of a pipe, under specified conditions, to withstand internal pressure of specified magnitude.

**ideal black, n**—object or material that absorbs all light impinging on it.

**illuminant, n**—*in color determination*, incident luminous flux specified only by its spectral distribution.

DISCUSSION—The spectral composition of an illuminant may differ from the source because of spectral modification by such means as absorption of refraction by mediae enclosing the source or by reflection from other objects. See **source**. The CIE standard illuminants are Illuminant C and Illuminant D6500, each representing average daylight, and Illuminant A, 2854K.

**inspector**—*in pipe laying*, an authorized representative of the engineer, or owner, assigned to make any and all necessary inspections of the work performed, including materials and equipment furnished.

**kink (in asbestos)**—definite, well defined change in direction of the asbestos in situ that could lead to points of weakness in the fibers when separated.

DISCUSSION—Asbestos in situ may be described as kinked or straight.

**lap cement**—the cementitious material used to seal the side and end laps of corrugated roofing.

**light, adj**—*highly reflecting*, as in the term light green.

**light, n**—electromagnetic radiation in the spectral range detectable by the normal human eye (approximately 380 to 760 nm).

**light, n**—*in color determination*, radiant energy evaluated according to the CIE photopic spectral luminous efficiency function.

**lining**—coating or layer adhered to or in intimate contact with the interior surface and ends of asbestos-cement pipe and related fittings, with said coating or layer being more

chemically resistant than the pipe and related fittings.

**loftiness**—the measure of the loose specific volume of an asbestos fiber. This is inversely related to the dry bulk density.

**lot, n**—*in asbestos*, not fewer than 2 and not more than 2000 bags of asbestos fiber of the same type and grade offered at any one time for delivery or testing.

**lot, n**—*in asbestos-cement conduit*, each 1000 lengths of conduit or less, of a given class, type and size manufactured on each machine during a 24-h period.

**lot, n**—*in asbestos-cement nonpressure sewer pipe*, for pipe sizes 150 mm (6 in.) and smaller, those lengths of pipe of that size, class and type manufactured during the same work shift. For pipe sizes 200 through 525 mm (8 through 21 in.), each 300 lengths of pipe or less, of identical size, class and type manufactured on each machine during a 24-h period. For pipe sizes larger than 525 mm (21 in.) each 300 lengths of pipe or less, of identical size, class and type manufactured on each machine during a period of consecutive working days not exceeding seven days.

**lot, n**—*in asbestos-cement pressure pipe, storm drain, and transmission pipe*, for pipe sizes 525 mm (21 in.) in diameter and smaller, each 300 lengths of pipe or less, of identical class and size manufactured on each machine during a 24-h period. For pipe larger than 535 mm (21 in.), each 300 lengths of pipe or less, of identical class and size manufactured on each machine during a period of consecutive working days not exceeding seven days.

**louver blade**—a shaped asbestos-cement product used to guard ventilation ports.

**luminous, adj**—*in color determination*, indicates that the radiant flux is evaluated by weighting according to the luminous efficiency function of the CIE 1931 standard observer.

**luminous reflectance, n**—see **reflectance, luminous**.

**magnetic rating (MR), n**—an empirical value reflecting the effect of the magnetic particles, such as magnetic iron compounds, in asbestos material as measured by a magnetic effect analyzer. It is not a quantitative measure of the magnetic particles in the material.

DISCUSSION—Magnetic rating is affected by the quantity, concentration, particle size, shape and orientation of the magnetic particles in the material.

**manufacturer, n**—*in pipe laying*, the party that manufactures, fabricates, or produces materials or products.

**mass-fiber**—asbestos that is randomly oriented in situ.

**master composite sample, n**—*in asbestos*, not less than two and not more than ten composite samples so combined and reduced as to form a test sample that represents a lot that consists of more than 200 bags but not more than 2000 bags.

**milled asbestos**—all grades of asbestos that are recovered as a result of mechanical comminution and screen classification or air classification of asbestos ore.

**milling**—a process by which asbestos ore is treated mechanically to produce grades of asbestos with specified properties.

**nonfibrous spicules**—acicular particles resembling assemblages of asbestos fibers composed of nonfibrous, or semi-fibrous minerals such as picrolite. See Table 3.

**observer, standard, CIE 1931**, *n*—in color determination, hypothetical observer based on color mixture data obtained for a 2° field of view for 17 real observers, adopted by the CIE in 1931.

**observer, supplementary, CIE 1964**, *n*—in color determination, hypothetical observer based on color mixture data obtained for a 10° field of view for 76 real observers, adopted by the CIE in 1964.

**open**—the quality of asbestos with a relatively high specific surface area and degree of fiberization, free from an appreciable portion of crudy material.

**organic fiber**—natural or synthetic fiber, having a length-to-diameter (or to maximum transverse dimension) ratio of at least 100 to 1.

**organic fiber content**, *n*—in asbestos-cement, the percentage of organic matter expressed as the equivalent percentage by mass of wood cellulose in a dried sample.

**owner**, *n*—in pipe laying, the person, firm corporation, or government agency entering into contract with the contractor for the installation of asbestos-cement pipe and accessories.

**package unit**, *n*—in pipe laying, several units of asbestos-cement pipe bound together for the purpose of being transported and, when desired, unloaded at the job site.

**pencil**—rod-like assemblage of asbestos fibers in close-packed parallel orientation, of generally uniform diameter that can be fiberized readily. See Table 3.

**photoelectric colorimeter**, *n*—color-stimulus-measuring instrument using photoelectric detectors in which source-filter-detector response characteristics are adjusted so that the instruments read directly the tristimulus<sup>12</sup> values or related quantities.

**physical stability**—in asbestos-cement products, the ability of the product to maintain its physical dimensions and properties when in contact with liquid, gaseous, or solid media normally encountered in its service environment.

**pigment**—water-insoluble solid coloring matter pulverized to a fine particle size and added to asbestos-cement products.

**pinch**, *n*—in sampling, as much fiber as can be taken up between the tips of the index finger and thumb.

**pitch**—the distance from center point to center point of adjacent crests of an asbestos-cement product of corrugated or grooved cross-section.

**pitch**, *n*—in cooling tower fill, the wave length of corrugated products.

**plans and specifications**, *n*—in pipe laying, documents prepared by the engineer or owner, or both, stipulating work to be done and materials to be used which, combined with other contract documents and Guide C 966, form the basis for a comprehensive contract between the owner and the contractor.

**point value**, *n*—in asbestos, an index of commercial value of asbestos fiber used in asbestos-cement products. Point value = (SU - 10)/1.39 where SU stands for strength unit.

**preferred white**, *n*—in color determination, the white color, usually bluish, that is judged by a given group of observers looking at a given series of specimens to be the whitest color attainable.

**pressed product**, *n*—in cooling tower fill, that which is pressed singly or in stacks interlayered with templates, at a minimum pressure of 12 MPa (1740 psi).

**purchaser**, *n*—in pipe laying, the person, company, or organization that purchases any materials or work to be performed.

**ranch type**—a type of asbestos-cement roofing shingle, rectangular in shape, which is lapped at the top and one side.

**random composite sample**, *n*—in asbestos, a composite sample in which each individual bag in the lot that is being sampled has an equal chance of being included in the composite sample.

**random sample**, *n*—in asbestos, a sample in which each individual bag in the lot examined has an equal chance of being included in the sample.

**referee sample**, *n*—in asbestos, a sample on which acceptability is based. Acceptability shall be based on a composite sample if the lot is 200 bags or less, or on a master composite sample if over 200 bags, but not in excess of 2000 bags.

**reflectance, luminous**, *n*—ratio of luminous flux reflected by a specimen to that incident on it.

**reflection**, *n*—processes by which incident flux leaves a surface from the incident side.

**reflection, diffuse**, *n*—process by which incident flux is distributed by reflection over a wide range of angles.

**regular**, *adj*—in color determination, used to indicate flux transmitted or reflected in the image-forming state.

DISCUSSION—The adjective specular is usually used to indicate regular mirror-reflected flux.

**riebeckite asbestos**, *n*—a member of the mineral group of monoclinic amphiboles derived from riebeckite (glaucophane) of the alkali amphibole series. Usually referred to by the varietal name *crocidolite*. Its empirical formula is  $\text{Na}_2\text{Fe}_3^{+2}\text{Fe}_2^{+3}(\text{Si}_8\text{O}_{22})(\text{OH},\text{F})_2$ . Its Chemical Abstracts number<sup>9</sup> is 12001-28-4 (see Table 1 and Table 2).

**shipment**, *n*—in asbestos, any consignment formed of one or several lots of asbestos fiber.

**side lap**—the shortest horizontal distance between the exposed side edge of a course of asbestos-cement roofing or siding material and the most proximate underlying area of roof deck or side wall not covered by the preceding adjacent course.

**silica**, *n*—in asbestos cement, pulverized silicon dioxide ( $\text{SiO}_2$ ) used as a filler or a part of the cementitious material. In the latter case, the material shall meet the requirements of Specification C 618.

**slaters' cement**—a type of caulking compound, usually gray in color, and used to cover exposed bolt heads or at the side and end laps of corrugated roofing and in other places where water-resistant putty-like material is desired.

**slip-fiber**—asbestos that is located in, or derives from, veins or seams in which the fibers are oriented approximately parallel to each other and inclined at a small angle to the boundaries of the vein or seam and usually not as closely packed as are cross-fibers.

**slope**—the incline of a roof expressed as a ratio of the height in millimetres (inches) of vertical rise per horizontal distance in metres (feet).

**soft (as in soft asbestos)**—description of asbestos with relatively high softness.

**softness**—inherent property of asbestos implying a high degree of flexibility and low cohesion.

**source, n**—*in color determination*, that which furnishes light or other radiation; real device by which radiant flux is produced (see **illuminant**).

**source, CIE standard, n**—see **standard source**.

**spectral, adj**—*in color determination*, indicates either a function of wavelength as in spectral transmittance, or spectral concentration, as in spectral flux.

**specular, adj**—same as regular when applied to reflection.

**specular gloss, n**—see **gloss, specular**.

**spelk**—rod-like close packed assemblage, of asbestiform structure, and of generally uniform diameter, that can be fiberized readily. See Table 3.

**spicule (in asbestos)**—acicular particle of nonfibrous minerals, superficially resembling a spelk, but which shatters rather than fiberize when subjected to mechanical force. See Table 3.

**standard, primary, n**—one whose calibration is determined by measurement according to specified parameters.

**standard, secondary, n**—standard calibrated by reference to another standard such as a primary, reference, laboratory, or working standard.

**standard observer, n**—*in color determination*—see **observer, standard**.

**standard source, n**—*in color determination*, light source whose spectral energy distribution is known or defined.

DISCUSSION—The CIE standard sources to represent incandescent-lamp light, sunlight, and daylight, are designated A, B and C, respectively.

**starters**—lateral sections of roofing shingles, usually 75 mm (3 in.) wide, and applied beneath the first course of shingles with slight overhang at the eaves.

**storm anchor (clip), n**—*in shingles*, a corrosion-resistant metal fastener with a flat base and a shank that fastens the concealed lower corner of each shingle to the exposed edge of the adjacent shingle.

**strength unit, n**—*in asbestos*, unit of reinforcing potential of asbestos fiber in asbestos-cement products. An asbestos fiber that yields a flexural modulus of rupture of 27 MPa at a product density of 1.6 g/cm<sup>3</sup> when used as 10 % of the furnish (dry ingredients) is defined as having 100 strength units. Therefore, the number of strength units of a given asbestos is equal to 1000/(% fiber required in the dry mix to yield 27 MPa at 1.6 g/cm<sup>3</sup>).

**supplier, n**—*in pipe laying*, the party who supplies material or services. A supplier may or may not be the manufacturer.

**systematic composite sample, n**—*in asbestos*, a composite sample that is obtained by taking every *n*th bag in the lot being sampled.

**systematic sample, n**—*in asbestos*, the sample that is formed from every *n*th bag of the lot to be examined.

**test specimen, n**—the specific portion of a test sample upon which a test is to be performed, and that is obtained by systematically reducing the size of the sample until a representative specimen of the required mass is obtained.

**texture, n**—a surface pattern as compared with a smooth finish.

**textured, adj**—*in evaluating the color of a surface*, structural quality of a surface determined by the topography of its constituents.

**texture product, n**—*in cooling tower fill*, a product with bas-relief motifs that extend the external surface of a sheet sufficiently to increase its heat transfer capacity by at least 10 % under conditions of turbulent flow.

**thermal resistance, R, n**—*in asbestos-cement plastic-foam core insulating panels*, the thermal gradient that will develop under a given steady state heat flow between two parallel unit area surfaces for a given material thickness.

**toplap**—the shortest distance between the lower edge of an overlapping shingle or sheet, and the upper edge of the lapped unit in the first course below (see Fig. 1).

**tremolite asbestos, n**—asbestiform variety of the monoclinic amphibole silicate minerals of the tremolite-actinolite (ferroactinolite) series. Its empirical formula is Ca<sub>2</sub>Mg<sub>5</sub>Si<sub>8</sub>O<sub>22</sub>(OH)<sub>2</sub>. Its Chemical Abstracts number<sup>9</sup> is 77536-66-4 (see Table 1 and Table 2).

**uncombined calcium hydroxide, n**—*in asbestos-cement*, the content of unreacted calcium hydroxide that remains in the sample of cured product when tested.

**underdrain**—a type of asbestos-cement pipe having a multiplicity of perforations along its length, intended for use in surface or below-surface drainage.

**unit magnetic rating (1 MR), n**—a calibrating standard with an MR of one is defined as containing 0.18 g of U.S. Institute of Standards and Technology standard sample No. 29 (a) or iron ore (magnetite) uniformly distributed over the space specified for a 10-g test specimen [14 mm (0.75 in.) diameter by 73 mm (2.875 in.) long], by dispersion in a magnetically inert material.<sup>13</sup> A 10-g specimen has one unit magnetic rating when it produces a magnetic effect equivalent to that of 0.18 g of standard magnetite as described above. Conversely, a 10-g specimen producing a magnetic effect such that the resulting induced current in the magnetic analyzer galvanometer is *k* times that of the 0.18 g of standard magnetite as described above, would have a magnetic rating (MR) of *k*.

**unit sample, n**—*in asbestos*, a sample drawn from one bag.

**veneer**—the decorative surface of an asbestos-cement shingle or sheet, usually pigmented or granulated for enhanced appearance.

**viewing conditions, n**—the conditions under which a visual observation is made, including the angular substance of the specimen at the eye; the geometric relationship of source, specimen and eye; the photometric and spectral character of the field of view surrounding the specimen; and the state of adaptation of the eye.

**warping**—deformation in the original flatness of an asbestos-cement flat product.

**water absorption**—increase in mass of a product during immersion in water under specified conditions of duration

<sup>13</sup> Detailed information on the preparation of calibration standards is available from ASTM Headquarters. Request Adjunct No. 12-411180-00 to Test Method D 1118.



and temperature, expressed as a percent of its dry mass.

**water repellent substances**—materials such as waxes, soaps, or silicones that render the surface of shingles more water repellent.

**white**, *adj*—*in color determination*, color description most usually applied to opaque, highly reflecting, highly diffusing, visually hueless specimens.

**whiteness**, *n*—*in asbestos fiber and products*, the degree to which a near-white surface approaches *perfect white* defined as a 100 % reflectance over the whole visible spectrum. Other terms used for this property are *lightness* or *luminous apparent reflectance*. The concept of whiteness is not only applicable to near-white surfaces but also to dark and colored surfaces. Whiteness may be defined as the grading which an observer would assign to the surface, irrespective of its color or hue, when compared under daylight conditions against a scale of grays ranging from white to black.

**yellow**, *adj*—hue description applied to light of wavelengths from 572 to 783 nm and to visually similar stimuli.

**yellowness**, *n*—*in asbestos fiber and products*, the degree to which asbestos deviates from colorlessness or neutral grey toward yellowish or tan as determined by the yellowness index.

**yellowness index**, *n*—*in asbestos fiber and products*, an index calculated arbitrarily from reflectance measurements using tristimulus<sup>12</sup> filters. Use the following relationship for asbestos:

$$\text{yellowness index} = (A - B)/G \quad (2)$$

where:

- A* = reflectance with the amber tristimulus filter,
- B* = reflectance with the blue tristimulus filter, and
- G* = reflectance with the green tristimulus filter.

NOTE 1—Additional definitions are presented in Specification C 296, Specification C 428, Test Method C 458, Test Methods C 500, Specification C 508, Specification C 541, Specification C 663, Specification C 668, Specification C 875, Guide C 966, Terminology D 123, Test Method D 1918, Test Method D 2985, Test Method D 2590, Test Method D 3879, and STP 834.<sup>10</sup>

#### 4. Keywords

4.1 actinolite; amosite; amphibole; anthophyllite; asbestos; chrysotile; color; crocidolite; cummingtonite; definitions; dimensions; ferroactinolite; floats; gederite; glaucophane; grunerite; riebeckite; terminology; terms; tremolite

*The American Society for Testing and Materials takes no position respecting the validity of any patent rights asserted in connection with any item mentioned in this standard. Users of this standard are expressly advised that determination of the validity of any such patent rights, and the risk of infringement of such rights, are entirely their own responsibility.*

*This standard is subject to revision at any time by the responsible technical committee and must be reviewed every five years and if not revised, either reapproved or withdrawn. Your comments are invited either for revision of this standard or for additional standards and should be addressed to ASTM Headquarters. Your comments will receive careful consideration at a meeting of the responsible technical committee, which you may attend. If you feel that your comments have not received a fair hearing you should make your views known to the ASTM Committee on Standards, 100 Barr Harbor Drive, West Conshohocken, PA 19428.*