



Standard Test Method for Diagonal Tension (Shear) in Masonry Assemblages¹

This standard is issued under the fixed designation E 519; the number immediately following the designation indicates the year of original adoption or, in the case of revision, the year of last revision. A number in parentheses indicates the year of last reapproval. A superscript epsilon (ϵ) indicates an editorial change since the last revision or reapproval.

This standard has been approved for use by agencies of the Department of Defense.

^ε1 ~~NOTE — The Celsius equivalent was added to Paragraph 5.3 editorially in March 2001.~~

1. Scope*

1.1 This test method covers determination of the diagonal tensile or shear strength of 1.2 by 1.2-m (4 by 4-ft) masonry assemblages by loading them in compression along one diagonal (see Fig. 1), thus causing a diagonal tension failure with the specimen splitting apart parallel to the direction of load.

1.2 Annex A1 provides requirements regarding the determination of the diagonal-tension strength of masonry under combined diagonal-tension and compressive loading.

1.3 The values stated in SI units are to be regarded as the standard. The values given in parentheses are provided for information only.

1.4 *This standard may involve hazardous materials, operations, and equipment. This standard does not purport to address all of the safety problems, if any, associated with its use. It is the responsibility of the user of this standard to establish appropriate safety and health practices and determine the applicability of regulatory limitations prior to use.*

2. Referenced Documents

2.1 ASTM Standards:

C 67 Test Methods for Sampling and Testing Brick and Structural Clay Tile²

¹ This test method is under the jurisdiction of ASTM Committee C15 on Manufactured Masonry Units and is the direct responsibility of Subcommittee C15.04 on Research. Current edition approved ~~June~~ Dec. 10, 2000². Published ~~September 2000~~ April 2003. Originally published as E 519-74; approved 1974. Last previous edition E 519-81(1999); approved in 2000 as E 519-00.



FIG. 1 Apparatus for Determination of Diagonal Tensile or Shear Strength Masonry Assemblages

C 109 Test Method for Compressive Strength of Hydraulic Cement Mortars (Using 2-in. or 50-mm Cube Specimens)³

C 140 Test Methods for Sampling and Testing Concrete Masonry Units and Related Units²

C 1019 Test Method for Sampling and Testing Grout²

E 4 Practices for Force Verification of Testing Machines⁴

E 575 Practice for Reporting Data from Structural Tests of Building Constructions, Elements, Connections, and Assemblies⁵

3. Significance and Use

3.1 This test method was developed to measure more accurately the diagonal tensile (shear) strength of masonry than was possible with other available methods. The specimen size was selected as being the smallest that would be reasonably representative of a full-size masonry assemblage and that would permit the use of testing machines such as are used by many laboratories.

NOTE 1—As a research test method used only for the purpose of evaluating the effects of variables such as type of masonry unit, mortar, workmanship, etc., a smaller size specimen could be used if the available testing equipment will not accommodate a 1.2-m (4-ft) square specimen. However, there is a lack of experimental data that would permit an evaluation of the effect of specimen size on the shear strength or to permit a correlation between the results of small-scale specimen tests and larger specimens.

4. Apparatus

4.1 *Testing Machine*— The testing machine shall have sufficient compressive load capacity and provide the rate of loading prescribed in 6.4. It shall be power-operated and capable of applying the load continuously, rather than intermittently, and without shock. It shall conform to the requirements of the Calculation and Report sections of Practices E 4.

² Annual Book of ASTM Standards, Vol 04.05.

³ Annual Book of ASTM Standards, Vol 04.01.

⁴ Annual Book of ASTM Standards, Vol 03.01.

⁵ Annual Book of ASTM Standards, Vol 04.07.

NOTE 2—In order to accommodate a 1.2-m (4-ft) square specimen placed in the machine so that its diagonal is in a vertical position, the machine should have a clear opening height of at least 2.13 m (7 ft).

4.2 *Loading Shoes*—Two steel loading shoes (see Fig. 2 and Fig. 3) shall be used to apply the machine load to the specimen. The length of bearing of the shoe shall be 152 mm (6 in.).

NOTE 3—Experimental work has indicated that the maximum length of bearing of the shoe should be approximately 1/8 the length of the edge of the specimen to avoid excessive bearing stress.

5. Test Specimens

5.1 *Size*—The nominal size of each specimen shall be 1.2 by 1.2 m (4 by 4 ft) by the thickness of the wall type being tested. The 1.2-m dimensions shall be within 6 mm (1/4 in.) of each other.

5.2 *Number of Specimens*—Tests shall be made on at least three like specimens constructed with the same size and type of masonry units, mortar, and workmanship.

5.3 *Curing*—After construction, specimens shall not be moved for at least 7 days. They shall be stored in laboratory air for not less than 28 days. The laboratory shall be maintained at a temperature of 24 ± 8°C (75 ± 15°F) with relative humidities between 25 and 75 %, and shall be free of drafts.

5.4 *Mortar*—Three 50-mm (2-in.) compressive strength cubes shall be molded from a sample of each batch of mortar used to build the specimens and stored under the same conditions as the specimens with which they are associated. The tests shall be conducted in accordance with Test Method C 109. The cubes shall be tested on the same day as the specimen.

5.5 *Masonry Units*—Masonry units shall be sampled and tested in accordance with the following applicable methods: Test Method C 67 for clay brick or tile or Method C 140 for concrete masonry units.

5.6 *Grout*—When specified, grout shall be sampled and tested in accordance with Test Method C 1019.

6. Procedure

6.1 *Placement of Loading Shoes* —Position the upper and lower loading shoes so as to be centered on the upper and lower bearing surfaces of the testing machine.

6.2 *Specimen Placement*—Seat the specimen in a centered and plumb position in a bed of gypsum capping material placed in the lower loading shoe. When necessary (see A1.3), fill the spaces between the specimen and the side-confining plates with the capping material also. Age the caps for at least 2 h before testing.

6.3 *Instrumentation*— When required, measure the shortening of the vertical diagonal and the lengthening of the horizontal diagonal under load in one of two ways as follows:

6.3.1 By compressometers and extensometers employing either dial micrometers or linear displacement transducers. Record the gage lengths.

6.3.2 By 150-mm (6-in.) bonded wire electrical resistance strain gages mounted along the two diagonals as close to their intersection as possible.

6.4 *Application of Load:*

6.4.1 For specimens without instrumentation, apply the load continuously to ultimate. Up to one half of the expected maximum load may be applied at any convenient rate, after which adjust the controls of the machine so that the remaining load is applied at a uniform rate so that the maximum load is reached in not less than 1 nor more than 2 min.

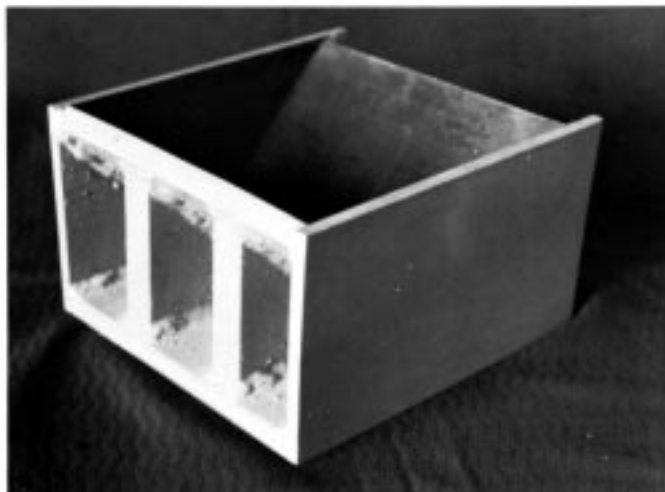
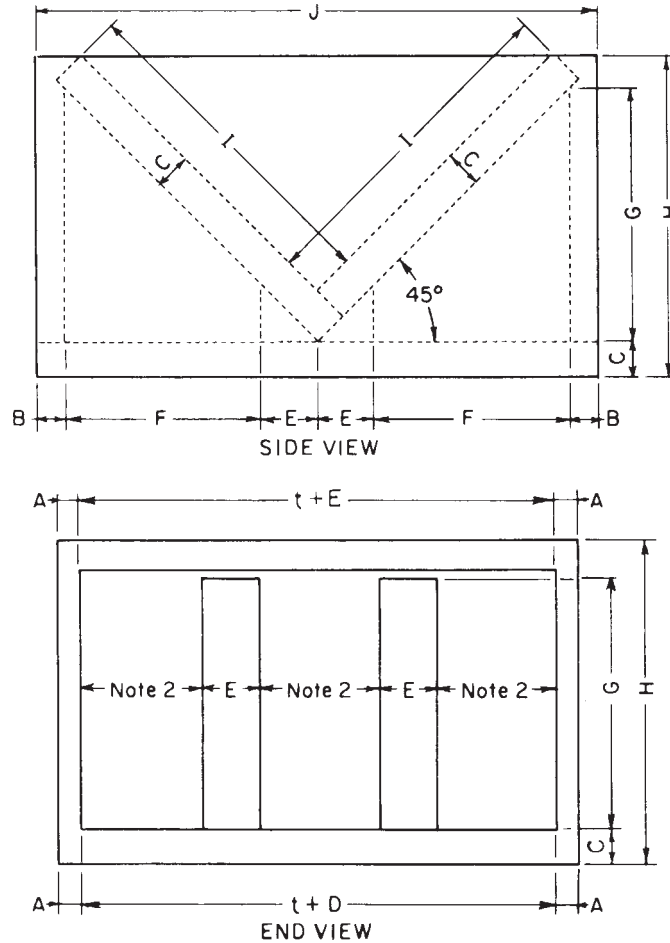

FIG. 2 Loading Shoe (Two Required)



NOTE 1—Material = cold-rolled steel.
 NOTE 2—Number and spacing of stiffeners will depend upon the thickness (*t*) of the wall specimen to be tested.

Table of Metric Equivalents					
	Metric Units, mm	Inch-Pound Units, in.		Metric Units, mm	Inch-Pound Units, in.
A	10	3/8	F	89	3 1/2
B	13	1/2	G	114	4 1/2
C	16	5/8	H	146	5 3/4
D	22	7/8	I	152	6
E	25	1	J	254	10

FIG. 3 Dimensions of Loading Shoe

6.4.2 For specimens instrumented for measuring deformations or strains, apply the loads in suitable increments at rates comparable to 6.4.1. Choose the increments so that at least ten deformation or strain readings will be obtained to determine definitely the stress-strain curve. Such readings should be obtained for loads as close to the ultimate load as feasible. When the behavior of the specimen under load indicates that it might fail suddenly and damage the deformation-measuring instruments, remove the instrumentation and apply the load continuously until the maximum load that can be applied to the specimen is determined.

7. Calculation

7.1 *Shear Stress*— Calculate the shear stress for specimens on the basis of net area. Calculate the shear stress of the specimen as follows:

$$S_s = \frac{0.707P}{A_n} \tag{1}$$

where:

S_s = shear stress on net area, MPa (psi),

P = applied load, N (lbf), and

A_n = net area of the specimen, mm²(in.²), calculated as follows:

$$A_n = \left(\frac{W + h}{2} \right) m \quad (2)$$

where:

w = width of specimen, mm (in.),

h = height of specimen, mm (in.),

t = total thickness of specimen, mm (in.), and

n = percent of the gross area of the unit that is solid, expressed as a decimal.

7.2 *Shear Strain*— When required, calculate the shear strain as follows:

$$\gamma = \frac{\Delta V + \Delta H}{g} \quad (3)$$

where:

γ = shearing strain, or mm/mm (in./in.),

ΔV = vertical shortening, mm (in.),

ΔH = horizontal extension, mm (in.), and

g = vertical gage length, mm (in.).

NOTE 4— ΔH must be based on the same gage length as for ΔV .

7.3 *Modulus of Rigidity*—Calculate the modulus of rigidity (modulus of elasticity in shear) as follows:

$$G = \frac{S_s}{\gamma} \quad (4)$$

where:

G = modulus of rigidity, MPa (psi).

8. Report

8.1 The report should be prepared in conformance with Practice E 575 and contain at least the following items:

8.1.1 Description of the masonry materials used to construct the specimen and their properties as determined by the appropriate ASTM standard,

8.1.2 Drawings of the masonry unit, the test specimen, and the details of the specimen's construction, including the size and location of the reinforcement materials,

8.1.3 Description of quality of workmanship used in building the specimen,

8.1.4 Age of specimen when tested,

8.1.5 Description of mode of failure, including drawings showing cracking pattern,

8.1.6 Tabulation of test results, to include specimen identification numbers, maximum loads, individual shear stress values, average stress value for the three specimens, standard deviation and coefficient of variation of the test results, and the average compressive strengths of the associated mortar cubes, and

8.1.7 Stress-strain curve for each specimen, when required.

9. Precision and Bias

9.1 No statement is made either on the precision or on the bias for testing the diagonal tension (shear) strength of masonry assemblages due to the variety of materials involved. Sufficient test data for all materials and combinations of materials are not presently available to permit the development of precision and bias statements.

10. Keywords

10.1 compressive strength; diagonal loading; diagonal tensile strength; diagonal tension; masonry assemblages; masonry units; mortar; shear; shear strength

(Mandatory Information)

A1. EDGE LOADING

A1.1 In a building, a wall subjected to a shear or racking load may also be subjected to axial loads normal to the bed joints. Such axial loads may result from only the dead load of the wall itself or, in the case of loadbearing shear walls, from the additional combination of dead and live loads applied by floor systems bearing on the wall.

A1.2 Test data resulting from the use of this test method, modified so that a constant and uniform compressive load is applied normal to the bed joints while the specimen is being subjected to a shear load, indicate that such edge loads can increase the shear resistance significantly. Fig. A1.1 shows the manner in which edge loads normal to the bed joints can be applied by means of a steel loading frame clamped to the specimen. The loads are applied by hydraulic jacks.

A1.3 Experience has shown that the higher loads required to produce a diagonal tensile failure of specimens with such edge loading will often result in a premature splitting failure due to compression at the triangular points of bearing. This can be avoided by the use of triangular confinement plates clamped or welded to the open ends of the loading shoes (Fig. 2) and the spaces between the plates and faces of the specimen filled with the capping material (6.2). The use of such confinement plates fully restrains the specimens against any premature end splitting, permitting them to fail ultimately in classical tensile splitting along the loaded diagonal.



FIG. A1.1 Application of Edge Loads by Clamping a Steel Loading Frame to the Specimen

SUMMARY OF CHANGES

Committee C15 has identified the location of selected changes to this standard since ~~E 519-81 (1999)~~ E 519 – 00 that may impact the use of this standard.

~~(1) New Paragraphs 5.5 and 5.6 were added.~~ Section 6.2 was revised to include a requirement for curing of specimen caps.

ASTM International takes no position respecting the validity of any patent rights asserted in connection with any item mentioned in this standard. Users of this standard are expressly advised that determination of the validity of any such patent rights, and the risk of infringement of such rights, are entirely their own responsibility.

This standard is subject to revision at any time by the responsible technical committee and must be reviewed every five years and if not revised, either reapproved or withdrawn. Your comments are invited either for revision of this standard or for additional standards and should be addressed to ASTM International Headquarters. Your comments will receive careful consideration at a meeting of the responsible technical committee, which you may attend. If you feel that your comments have not received a fair hearing you should make your views known to the ASTM Committee on Standards, at the address shown below.

This standard is copyrighted by ASTM International, 100 Barr Harbor Drive, PO Box C700, West Conshohocken, PA 19428-2959, United States. Individual reprints (single or multiple copies) of this standard may be obtained by contacting ASTM at the above address or at 610-832-9585 (phone), 610-832-9555 (fax), or service@astm.org (e-mail); or through the ASTM website (www.astm.org).