



Standard Test Method for Critical Radiant Flux of Exposed Attic Floor Insulation Using an Electric Radiant Heat Energy Source¹

This standard is issued under the fixed designation C 1485; the number immediately following the designation indicates the year of original adoption or, in the case of revision, the year of last revision. A number in parentheses indicates the year of last reapproval. A superscript epsilon (ϵ) indicates an editorial change since the last revision or reapproval.

1. Scope

1.1 This test method covers a procedure for measuring the critical radiant flux of exposed attic floor insulation subjected to a flaming ignition source in a graded radiant heat energy environment inside a test chamber. The test specimen can be any attic floor insulation. This test method is not applicable to those insulations that melt or shrink away when exposed to the radiant heat energy environment or the ignition source.

1.2 This test method measures the critical radiant flux at the farthest point to which the flame advances. It provides a means for relative classification of a fire test response standard for exposed attic floor insulation. The imposed radiant flux simulation levels of thermal radiation are likely to impinge on the surface of exposed attic insulation from roof assemblies heated by the sun and by heat or flames of an incidental fire which may involve an attic space. This test method is intended to simulate an important element of fire exposure that may develop in open attics, but is not intended for use in describing flame spread behavior of insulation installed other than on an attic floor.

1.3 The values stated in SI units are to be regarded as standard. The values given in parentheses are for information only.

1.4 This standard is used to measure and describe the response of materials, products, or assemblies to heat and flame under controlled conditions, but does not by itself incorporate all factors required for fire hazard or fire risk assessment of the material, products, or assemblies under actual fire conditions.

1.5 *This standard does not purport to address all of the safety concerns, if any, associated with its use. It is the responsibility of the user of this standard to establish appropriate safety and health practices and determine the applicability of regulatory limitations prior to use.*

2. Referenced Documents

2.1 ASTM Standards:

C 168 Terminology Relating to Thermal Insulation Materials²

¹ This test method is under the jurisdiction of ASTM Committee C16 on Thermal Insulation and is the direct responsibility of Subcommittee C16.31 on Chemical and Physical Properties.

Current edition approved Nov. 10, 2000. Published February 2001.

² *Annual Book of ASTM Standards*, Vol 04.06.

3. Terminology

3.1 Definitions:

3.1.1 For definitions of terms used in this specification, see Terminology C 168.

3.2 Definitions of Terms Specific to This Standard:

3.2.1 *critical radiant flux*—the level of incident radiant heat energy on the attic floor insulation system at the most distant flame-out point in W/cm^2 ($\text{Btu}/\text{ft}^2\text{s}$).

3.2.2 *flux profile*—the curve relating incident radiant heat energy on the specimen plane to distance from the point of initiation of flaming ignition, that is, 0.0 cm. (0.0 in.).

3.2.3 *graded radiant energy*—the heating element is placed on an angled plain.

3.2.4 *total flux meter*—the instrument used to measure the level of radiant heat energy incident on the specimen plane at a given point.

3.2.5 *screed*—gently remove the excess material using a metal straight edge to leave a uniform surface on the insulation flush with the top of the container.

3.2.6 *voltage regulator*—a regulated constant voltage transformer equipped with a voltmeter shall be connected between the chamber and the power source. This will be maintained at 115 ± 5 volts.

4. Summary of Test Method

4.1 A horizontally mounted insulation specimen is exposed to the heat from an electric radiant heat energy panel located above and inclined at 30° to the specimen. After a short preheat, the hottest end of the specimen is ignited with a small flame. The distance to the farthest advance of flaming is measured, converted to watts per square centimeter from a previously prepared graph of the radiant flux profile, and reported as the critical radiant flux.

5. Significance and Use

5.1 This test method is designed to provide a basis for estimating one aspect of the fire exposure behavior of exposed insulation installed on the floor of an open attic. The test environment is intended to simulate attic floor exposure to radiant heat conditions. Radiant heat has been observed and defined in full-scale attic experiments.

6. Apparatus

6.1 Radiant Panel Test Chamber:

NOTE 1—Hardware Description for Electric Radiant Panel in Fig. 1:

1. Toggle switch
2. Exhaust fan
3. Thermometer
4. Aluminum flat welded on under side of angle for rod support
5. 1 cm (3/8 in.) rod (ready bolt)
6. Electric heat element (650 watt chromalox)
7. Aluminum angle 2.5 cm (1 in.) (tray slide rails)
8. Aluminum angle 4 cm (1.5 in.) (all framing)
9. Lock nuts for rods
10. Viewing glass 6 mm (1/4 in.)
11. Cement board or ceramic tile backerboard 6 mm (1/4 in.)
12. Flat aluminum with holes for rod and heat element twisted to fit

NOTE 2—Measurements Electric Radiant Panel in Fig. 1:

A. 32.5 cm (13 in.)	H. 71 cm (28 in.)	O. 20 cm (8 in.)
B. 10 cm (4 in.)	I. 60 cm (24 in.) refer- ence point	P. 7.5 cm (3 in.)
C. 13 cm (5 in.)	J. 33 cm (13 in.)	Q. 16 cm (6.25 in.)
D. 25.5 cm (10 in.)	K. 57 cm (23 in.)	R. 80 cm (32 in.)
E. 30.5 cm (12 in.)	L. 65 cm (26 in.)	S. 20 cm (8 in.)
F. 57 mm (2.25 in.)	M. 19 cm (7.5 in.)	T. 7.5 cm (3 in.)
G. 25.5 mm (10 in.)	N. 33 cm (13.25 in.)	

NOTE 3—Electric radiant panel manufactured by Clayville Insulation Labs, P.O. Box 713, Burley, ID 88318.

6.1.1 *Cabinet*, consists of an angle aluminum frame faced on four sides with cement fiber board or ceramic tile backerboard 6 mm (1/4 in.) and approximate overall dimensions of 80 cm (32 in.) high by 71 cm (28 in.) long by 30 cm (12 in.) deep with a viewing window along the front side and a vertical cement fiber board sliding on the right-hand end.

6.1.2 *Specimen Holder*, an open-top 0.16 mm (22–26 U.S. standard gage) thick stainless steel sheet with the vertical edges of the tray overlapped, not to exceed 7 mm (0.273 in.) in seam width, and joined to be watertight. Tray with outside dimension measuring exactly 60 cm (24 in.) long, by 15 cm (6 in.) wide by 5.0 cm (2 in.) deep.

6.1.3 *Radiant Heat Energy Source*, consists of a 110 V, 650 W, 1.3 cm (1/2 in.) diameter heating element that is 35 cm (14 in.) long, mounted in a stainless steel reflector with overall dimensions of 49 cm (19.5 in.) long by 9.5 cm (3.75 in.) wide. The heater is mounted inside the cabinet at a 30° angle to the horizontal rising away from the door.

6.1.4 *Dial Temperature Gage*, shall be a panel mount type attached onto the front of the cabinet to monitor the interior cabinet temperature and placed in the back upper left quadrant at 7.5 cm (3 in.) from the top and 20 cm (8 in.) from the back. The gauge shall have a range of 0 to 121°C (32 to 250°F) graduated in 2°C (2°F) increments.

6.1.5 *Exhaust Fan*, shall be mounted into the top of the cabinet at the opposite end from the door, unobstructed air flow out. The fan is 76 mm (3 in.) in diameter, 0.76 cfm (30 cfm), operating on 120 V.

6.1.6 *Control Switches*, two toggle switches are mounted on the top of the cabinet adjacent to the fan and are used to energize the exhaust fan and radiant energy source. Household switches have worked well.

6.1.7 *Environment*—The radiant panel test chamber employed for this test shall be located in a draft-protected area and maintained at $21 \pm 2^\circ\text{C}$ ($70 \pm 4^\circ\text{F}$) and a relative humidity of $50 \pm 20\%$.

6.1.8 *A Reliable 115 ± 5 Volts Power Source*,

7. Calibration and Standardization Apparatus

7.1 Apparatus:

7.1.1 Total Flux Meter:

7.1.1.1 *Overall Dimensions*—15 cm (6 in.) × 15 cm (6 in.) × 10 cm (4 in.),

7.1.1.2 All metal case,

7.1.1.3 110v AC (high impedance),

7.1.1.4 Calibrated to a national standard,

7.1.1.5 Direct readout in W/cm^2 shall read to three decimal places.

7.1.2 Heat Flux Transducer:

7.1.2.1 *Range*—0 to $1.5 \text{ W}/\text{cm}^2$,

7.1.2.2 Water cooled, and

7.1.2.3 Calibrated to a national standard.

7.1.3 Dummy Specimen Calibration Board:

7.1.3.1 *Overall Dimensions*—5 cm (2 in.) × 60 cm (24 in.) × 15 cm (6 in.), and

7.1.3.2 *Centered Calibration Hole*—2.5 cm (1 in.) in diameter centered on and along the centerline at 10 cm (4 in.), 20 cm (8 in.), 30 cm (12 in.), 40 cm (16 in.), and 50 cm (20 in.) locations (within ± 0.1 cm) measured from the zero reference at the maximum flux end of the specimen.

7.2 Radiant Heat Energy Flux Profile Standardization:

7.2.1 Place heat flux meter within 1 m (3 ft.) of the radiant panel.

7.2.2 Connect either of the cooling lines of the heat flux transducer to a tap water outlet. Connect the other side to discharge and drain (plastic tubing obtainable at a hardware store will work).

7.2.3 Establish a flow of 300 to 700 mL/min.

7.2.4 Plug the heat flux meter into the voltage regulator.

7.2.5 The heat flux transducer should be connected to the heat flux meter.

NOTE 4—Check the reflector on the radiant heat source to see that it is clean. If it needs cleaned, do so before it is turned on for calibration. Heat flux transducer and heat flux meter must be calibrated together to a standard source. They are not interchangeable between calibrations periods to a standard reference.

7.2.6 Turn on the radiant panel heat element and let it heat up to a steady-state temperature. Normally this takes about one hour. The steady-state temperature of the radiant panel cabinet is $49 \pm 5^\circ\text{C}$ ($120 \pm 10^\circ\text{F}$) which is measured by the thermometer above the radiant heat element. However, the cabinet temperature is very dependent on the room temperature. If the room temperature varies, so may the calibration. Reaffirm the cooling water flow and allow the meter to stabilize which could take up to 10 to 15 min. Water temperature should be approximately 21°C (70°F) to avoid condensation on heat flux transducer.

7.2.7 Open the sample entry door and place the dummy specimen on the slide rails. Push the dummy specimen in until it is flush with the rear wall of the panel and allow three minutes to preheat.

7.2.8 Insert the heat flux transducer into the 10 cm (4 in.) hole of the dummy board, making certain that the silver ring {ring larger than 2.54 cm (1.0 in.) that will not go through the dummy board hole} is flush with the bottom of the dummy specimen, and parallel to the plain of the dummy specimen.

Leave the transducer in position for thirty seconds or until it gives a stable reading. Read the value on the heat flux meter to three significant digits.

NOTE 5—The value on the heat flux meter is in watts per centimetre squared (W/cm^2).

7.2.9 Record the reading obtained.

7.2.10 Move the transducer to the 20 cm (8 in.), 30 cm (12 in.), 40 cm (16 in.) and 50 cm (20 in.) calibration holes and follow the procedure in 6.2.8.

7.2.11 Remove the dummy board from the radiant panel.

7.2.12 With a french curve carefully draw a smooth line through the data points in plotting the W/cm^2 values for each point 10 cm (4 in.), 20 cm (8 in.), 30 cm (12 in.), 40 cm (16 in.), and 50 cm (20 in.) on graph paper 20 × 20 per in.). This will be the calibration curve or flux profile curve.

8. Sample Preparation and Conditioning (See Fig. 4)

8.1 *Sample Preparation*—Blow the sample material through a commercial insulation blower using 30.0 of 5.0 cm (100 ft of 2 in.) hose into a box while holding the hose horizontally at a height of 122 cm (4 ft).³

8.2 Condition the samples to equilibrium at $21 \pm 2.0^\circ C$ ($70 \pm 3.6^\circ F$) and $50 \pm 5\%$ relative humidity in an open-top mesh bottom container not exceeding 10.0 cm (4 in.) in depth and position in such a way to allow free movement of air on the exposed sides. A change in net weight of the specimen that is less than 1% in two consecutive measurements with 24 h between each measurement constitutes equilibrium.

9. Test Procedure

9.1 With the specimen tray removed from the chamber, turn on the two toggle switches located in the top back of the instrument.

³ The Krendel M-200 hopper and #8910 Tornado blower (Krendal Machine Co., Inc 122 Summers Lane Delphose, OH 45833) have been found suitable for this purpose, although other blowers may be suitable.

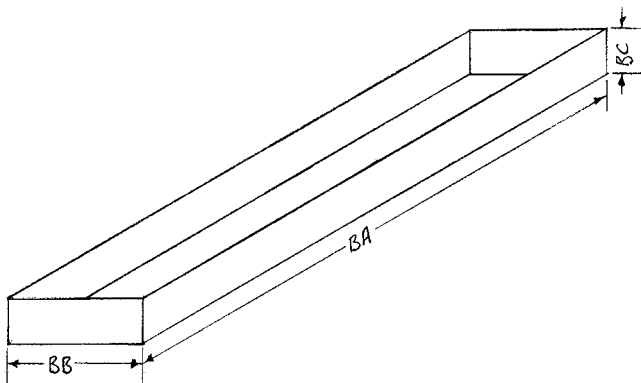

NOTE 1—*Hardware Description for Specimen Tray* in Figs. 2-4. Open top box 0.16 mm (0.024 in.) thick (22–26 US standard gage) stainless steel sheet with the vertical edges of the box overlapped not to exceed 7 mm (0.273 in.) in seam width, and joined to be watertight.

NOTE 2—*Measurements for Specimen Tray* in Fig. 2:

BA.	60 cm (24 in.)
BB.	15 cm (6 in.)
BC.	5 cm (2 in.)

FIG. 2 Specimen Tray

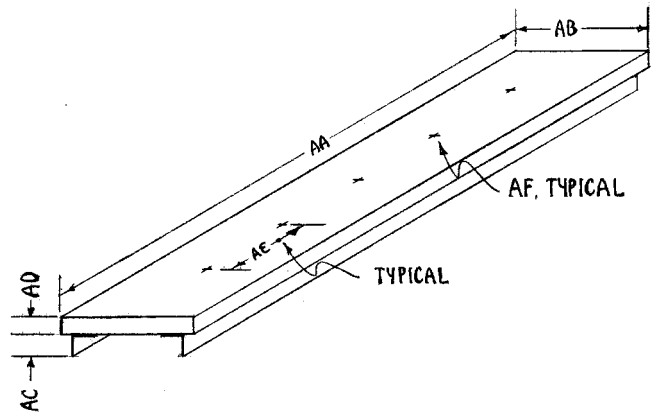

NOTE 1—*Hardware Description for Dummy Specimen Calibration Board* in Fig. 3:

4. Calcium silicate board or cement board
5. Aluminum angle 2.5 cm (1 in.) (slide rails)
6. Bolt or screw to hold board to angle

NOTE 2—*Measurements for Dummy Specimen Calibration Board*:

- AA. 60 cm (24 in.) Exact
- AB. 15 cm (6 in.)
- AC. 2.5 cm (1 in.)
- AD. 19 mm (.75 in.)
- AE. 10 cm (4 in.)
- AF. 2.5 cm (1 in.) drilled hole

FIG. 3 Dummy Specimen Calibration Board

9.2 Allow the heat element to preheat, the cabinet temperature will come to an operating temperature of $49 \pm 5^\circ C$ ($120 \pm 10^\circ F$). This may take around 1 h. Record the steady-state cabinet temperature.

9.3 Pour or scoop pre-blown and conditioned insulation into the specimen tray until the material overflows.

9.4 Using a metal straight edge (or equivalent), slowly screed off the material level with the upper edges of the specimen tray.

9.5 The specimen should be taken to the testing area and allowed to stabilize for 10 min to room temperature.

9.6 Open the cabinet door, insert the filled sample tray, making certain that the tray is flush against the opposite end of the chamber.

9.7 Close the entry door and allow the specimen to condition for a period of 3 min.

9.8 At the end of the 3 min conditioning period, open the entry door and ignite the specimen at high flux end, using an appropriate flame source. Close door immediately.

NOTE 6—An appropriate flame source is a fireplace match.

9.9 Allow the specimen to burn until flame-out.

9.10 Upon flame-out, remove the specimen tray, measure the distance from the outside of the tray at the ignition end to the maximum burn point and record.

9.11 If the chamber temperature is above the chamber steady-state temperature previously recorded, allow it to come back to that temperature before the next test is started.

9.12 Repeat 8.3 thru 8.11 for a total of three tests, using new specimen material for each test.

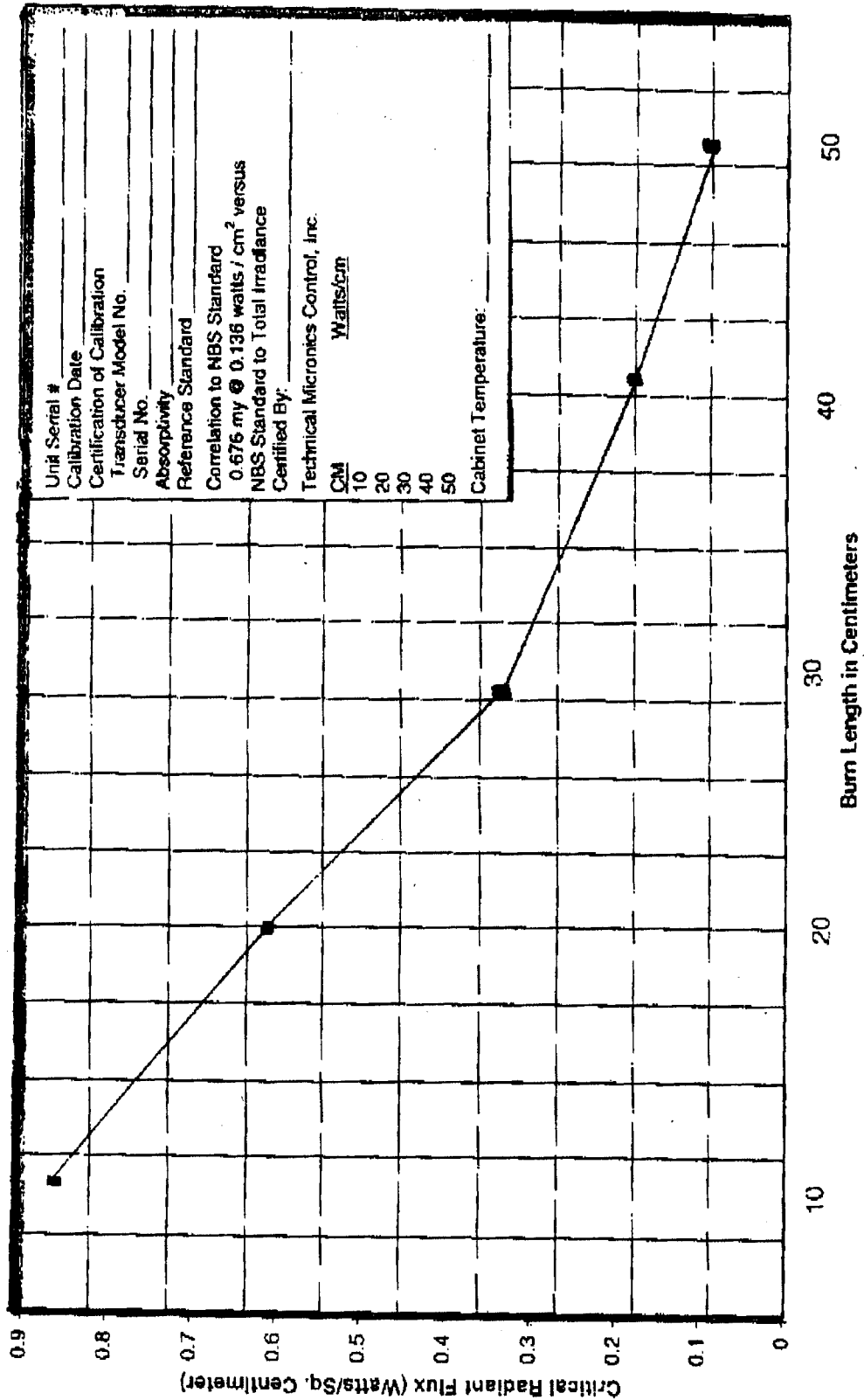

FIG. 4 Example Curve

10. Interpretation of Results

10.1 After determining the three burn distances, refer to the

calibration curve for the determination of the critical radiant flux.

NOTE 7—The burn distance is plotted to the nearest 0.5 cm (0.25 in.). The critical radiant flux is plotted to the nearest 0.01 W/cm².

10.2 The curve is read by locating the determined burn distance on the calibration curve. Reading from this point up to the plotted curve, then left to the value in w/cm².

11. Precision and Bias

11.1 The precision and bias of this test method is not known because inter-laboratory data are not available. Inter-laboratory data are being obtained and a precision statement will be added.

11.2 No information can be presented on the bias of the procedure in this test method because no material having an accepted reference value is available.

12. Keywords

12.1 electric radiant panel; heat flux; radiant panel

The American Society for Testing and Materials takes no position respecting the validity of any patent rights asserted in connection with any item mentioned in this standard. Users of this standard are expressly advised that determination of the validity of any such patent rights, and the risk of infringement of such rights, are entirely their own responsibility.

This standard is subject to revision at any time by the responsible technical committee and must be reviewed every five years and if not revised, either reapproved or withdrawn. Your comments are invited either for revision of this standard or for additional standards and should be addressed to ASTM Headquarters. Your comments will receive careful consideration at a meeting of the responsible technical committee, which you may attend. If you feel that your comments have not received a fair hearing you should make your views known to the ASTM Committee on Standards, at the address shown below.

This standard is copyrighted by ASTM, 100 Barr Harbor Drive, PO Box C700, West Conshohocken, PA 19428-2959, United States. Individual reprints (single or multiple copies) of this standard may be obtained by contacting ASTM at the above address or at 610-832-9585 (phone), 610-832-9555 (fax), or service@astm.org (e-mail); or through the ASTM website (www.astm.org).