



Designation: C 636 – 03

Standard Practice for Installation of Metal Ceiling Suspension Systems for Acoustical Tile and Lay-In Panels¹

This standard is issued under the fixed designation C 636; the number immediately following the designation indicates the year of original adoption or, in the case of revision, the year of last revision. A number in parentheses indicates the year of last reapproval. A superscript epsilon (ϵ) indicates an editorial change since the last revision or reapproval.

This standard has been approved for use by agencies of the Department of Defense.

1. Scope

1.1 This practice covers the installation of suspension systems for acoustical tile and lay-in panels. It is applicable to contractors whose services are utilized for installing acoustical ceilings and to other trades if their activities are responsible for interference with ceiling components or performance as defined in this recommended practice.

1.2 While the practices described in this document have equal application to rated fire-resistive suspension systems, additional requirements may have been imposed to obtain the fire endurance classification of particular floor-ceiling or roof-ceiling assemblies. These details should be obtained from the manufacturers.

1.3 Similarly, additional detailing may be necessary to meet sound attenuation requirements when ceiling plenums extend over contiguous rooms. These, too, should be obtained from the manufacturer of the acoustical material employed.

1.4 The values stated in inch-pound units are to be regarded as the standard.

1.5 While many of the practices described in this practice have application to the installation of metal suspension systems in exterior environments, the specific design of exterior ceiling installations requires the review and approval of the architect, engineer, or both, who are responsible for the construction of the building or modifications to an existing building. While recommendations from the manufacturer should be solicited, it remains the final responsibility of the architect/engineer to ensure proper application of the materials in question.

1.6 *This standard does not purport to address of the safety concerns, if any, associated with its use. It is the responsibility of the user of this standard to establish appropriate safety and health practices and determine the applicability of regulatory limitations prior to use.*

2. Installation of Components

2.1 Hangers:

2.1.1 Where acoustical ceilings are suspended from a structure of wood construction, attach hangers with suitable mechanical devices either to the bottom edge of the wood joists or to the vertical face of the wood joists near the bottom edge. Holding power tests certified by the manufacturer must be available on request for bottom edge attachment devices.

2.1.2 Where acoustical ceilings are suspended from a structure of concrete construction, mount hangers using cast-in-place hanger wires, hanger inserts, or other hanger attachment devices whose suitability has been demonstrated by standard construction practice or by certified test data.

2.1.3 Space hangers for carrying channels or main runners 4 ft 0 in. (1.2 m) on centers. If local situations allow greater center distances between hangers, reduce the load-carrying capacity of the ceiling suspension system commensurate with the actual center-to-center hanger distances used. If local situations allow lesser center distances between hangers, increase the load-carrying capacity of the ceiling suspension system commensurate with the actual center-to-center hanger distances used.

2.1.4 Each suspension wire shall not hang more than one in six out of plumb unless a countersloping wire or horizontal bracing is provided. See Fig. 1 for allowable countersloping methods. Suspension wires should not press against ducts or pipes.

2.1.5 Hangers formed from galvanized sheet metal stock shall be suitable for suspending carrying channels or main runners from an existing structure provided that the hangers do not yield, twist, or undergo other objectionable movement.

2.1.6 Wire hangers for suspending carrying channels or main runners from an existing structure shall be prepared from a minimum of No. 12-gage (2.05-mm) galvanized, soft-annealed, mild steel wire.

2.1.7 In some installations hanger wires are secured to special attachment devices that support the carrying channels or main runners. Such attachment devices shall have certified load test data from an independent test laboratory and shall be capable of carrying five times the design load.

2.2 Carrying Channels:

2.2.1 Install the carrying channels so that they are all level to within $\frac{1}{8}$ in. in 12 ft (3.2 mm in 3.66 m).

¹ This practice is under the jurisdiction of ASTM Committee E33 on Environmental Acoustics and is the direct responsibility of Subcommittee E33.04 on Application of Acoustical Materials and Systems.

Current edition approved Oct. 1, 2003. Published October 2003. Originally approved in 1969. Last previous edition approved in 1996 as C 636 – 96.

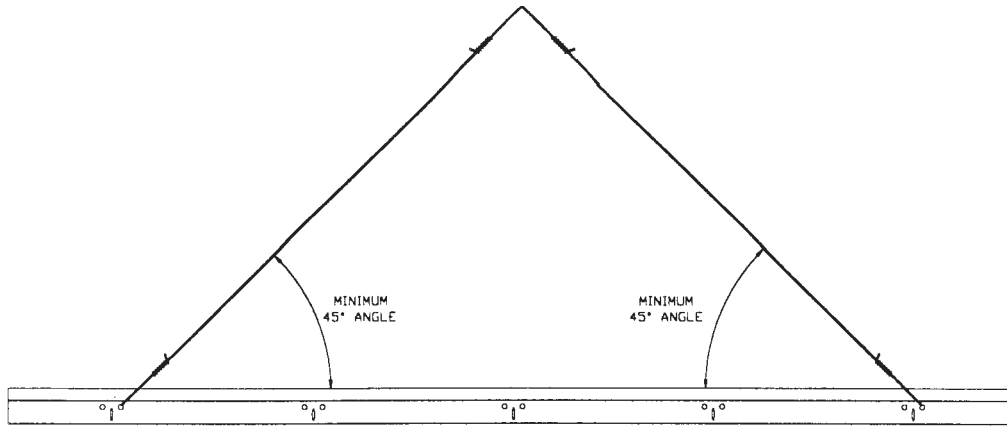

METHOD 1

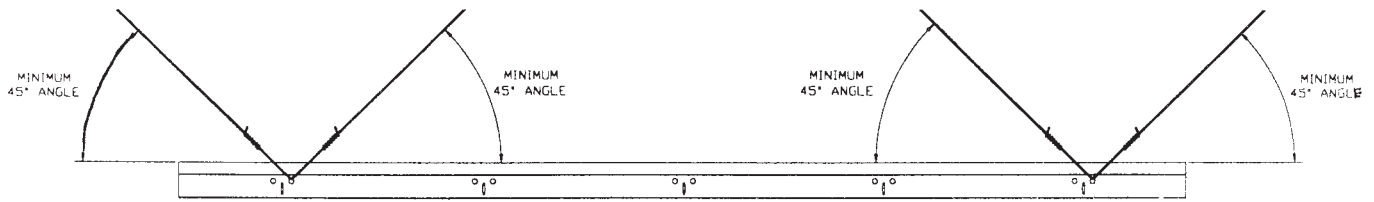

METHOD 2

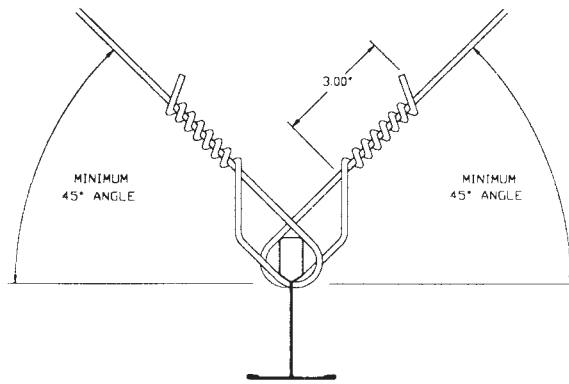

METHOD 3

FIG. 1 Allowable Countersloping Methods

2.2.2 Perform leveling with the supporting hangers taut to prevent any subsequent downward movement of the carrying channels when the ceiling loads are imposed.

2.2.3 Local kinks or bends shall not be made in hanger wires as a means of leveling carrying channels.

2.2.4 In installations where hanger wires are wrapped around carrying channels, the wire loops shall be tightly

formed to prevent any vertical movement or rotation of the member within the loop.

2.3 Main Runners:

2.3.1 Install main runners so that they are all level to within 1/4 in. in 10 ft (6.4 mm in 3.05 m). Determine evaluation of levelness from measurements taken below hanger points. Make

the measurements after completion of the ceiling installations but prior to building occupancy.

2.3.2 Where main runners are supported directly by hangers, perform leveling with the supporting hanger taut to prevent any subsequent downward movement of the main runners when the ceiling loads are imposed.

2.3.3 Local kinks or bends shall not be made in hanger wires as a means of leveling main runners.

2.3.4 In installations where hanger wires are wrapped through or around main runners, the wire loops shall be tightly wrapped and sharply bent to prevent any vertical movement or rotation of the member within the loops. The wire must be wrapped around itself a minimum of three full turns (360° each) within a 3-in. length. See Fig. 2 for an example.

2.4 Cross Runners:

2.4.1 Install cross runners supported by either main runners or by other cross runners to within $\frac{1}{32}$ in. (0.79 mm) of the required center distances. This tolerance shall be noncumulative beyond 12 ft (3.66 m).

2.4.2 Intersecting runners shall form a right angle.

2.4.3 The exposed surfaces of two intersecting runners shall lie within a vertical distance of 0.015 in. (0.38 mm) of each other with the abutting (cross) member always above the continuous (main) member.

2.5 *Splines*—Splines used to form a concealed mechanical joint seal between adjacent tiles shall be compatible with the tile kerf design so that the adjacent tile will be horizontal when installed. Where splines are longer than the dimension between edges of supporting members running perpendicular to the splines, place the splines so that they rest either all above or all below the main running members.

2.6 Assembly Devices:

2.6.1 Join abutting sections of main runner by means of suitable connections such as splices, interlocking ends, tab locks, pin locks, etc. A joint connection shall be judged suitable both before and after ceiling loads are imposed if the joint provides sufficient alignment so that the exposed surfaces of two abutting main runners lie within a vertical distance of 0.015 in. (0.38 mm) of each other and within a horizontal distance of 0.015 in. (0.38 mm) of each other.

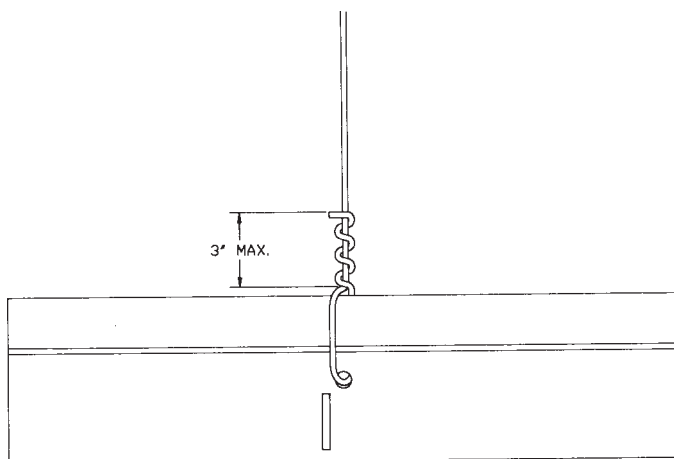

FIG. 2 Hanger Wire Tie Detail

2.6.2 There shall be no visually apparent angular displacement of the longitudinal axis of one runner with respect to the other.

2.6.3 Assembly devices shall provide sufficient spacing control so that horizontal gaps between exposed surfaces of either abutting or intersecting members shall not exceed 0.020 in. (0.51 mm).

2.6.4 Spring wire clips used for supporting main runners shall maintain tight contact between the main runners and the carrying channels when the ceiling loads are imposed on the runners.

2.7 Ceiling Fixtures:

2.7.1 Mount fixtures installed in acoustical tile or lay-in panel ceilings in a manner that will not compromise ceiling performance.

2.7.2 Fixtures shall not be supported from main runners or cross runners if the weight of the fixture causes the total dead load to exceed the deflection capability of the ceiling suspension system. In such cases, the fixture load shall be supported by supplemental hangers within 6 in. (152 mm) of each corner, or the fixture shall be separately supported.

2.7.3 Fixtures shall not be installed so that main runners or cross runners will be eccentrically loaded except where provision is inherent in the system (or is separately provided for) to prevent undesirable section rotation or displacement, or both. In any case, runners supporting ceiling fixtures shall not rotate more than 2° after the fixture loads are imposed.

2.7.4 Where fixture installation would produce rotation of runners in excess of 2°, install fixtures with the use of suitable accessory devices. These devices shall support the fixture in such a manner that main runners and cross runners will be loaded symmetrically rather than eccentrically.

3. Interference of Ceiling Related Components

3.1 The specifier shall designate the type of suspension system to be employed and shall communicate to all parties concerned the necessary details of the acoustical ceiling to satisfactorily identify the number, size, spacing, location, and types of fixtures to be accommodated in or above the ceiling.

3.2 Prior to the beginning of ceiling work at a construction site, the ceiling contractor and other contractors whose work is related to the ceiling installation shall designate all areas of potential interference between ceiling components and components from other trades.

3.3 All areas of interference that arise following the beginning of ceiling construction shall be reported by the contractors involved to the general contractor or the specifier, or both, as soon as the interference is observed.

4. Appearance

4.1 Lighting:

4.1.1 Where light from fixtures, cove lights, or high windows strikes the surface at a small angle, even slight unevenness of joints of acoustical tile may result in unsatisfactory appearance. Under such conditions beveled tile should be used in preference to square edge tile and installed with considerable care.

4.1.2 The unfavorable appearance sometimes produced by edge lighting of ceilings suggests the desirability of using flush

or recessed mounted lighting fixtures wherever this problem may be a critical one. Ceiling shadows cast by strong natural light coming through high windows also suggests the desirability of using tinted glass, blinds or draperies to soften or diffuse the light entering such openings.

5. Inspection

5.1 The inspection of specific ceiling areas for acceptability shall be made with lighting conditions corresponding to that of

final building occupancy. If temporary lighting must be used, care shall be taken to position lights such that temporary conditions will approximate the final lighting condition.

6. Keywords

6.1 acoustical tile; lay-in panels; metal ceiling suspension system; suspension systems

ASTM International takes no position respecting the validity of any patent rights asserted in connection with any item mentioned in this standard. Users of this standard are expressly advised that determination of the validity of any such patent rights, and the risk of infringement of such rights, are entirely their own responsibility.

This standard is subject to revision at any time by the responsible technical committee and must be reviewed every five years and if not revised, either reapproved or withdrawn. Your comments are invited either for revision of this standard or for additional standards and should be addressed to ASTM International Headquarters. Your comments will receive careful consideration at a meeting of the responsible technical committee, which you may attend. If you feel that your comments have not received a fair hearing you should make your views known to the ASTM Committee on Standards, at the address shown below.

This standard is copyrighted by ASTM International, 100 Barr Harbor Drive, PO Box C700, West Conshohocken, PA 19428-2959, United States. Individual reprints (single or multiple copies) of this standard may be obtained by contacting ASTM at the above address or at 610-832-9585 (phone), 610-832-9555 (fax), or service@astm.org (e-mail); or through the ASTM website (www.astm.org).