



Designation: C 692 – 9700

Standard Test Method for Evaluating the Influence of Thermal Insulations on External Stress Corrosion Cracking Tendency of Austenitic Stainless Steel¹

This standard is issued under the fixed designation C 692; the number immediately following the designation indicates the year of original adoption or, in the case of revision, the year of last revision. A number in parentheses indicates the year of last reapproval. A superscript epsilon (ϵ) indicates an editorial change since the last revision or reapproval.

1. Scope

1.1 This test method covers two procedures for the laboratory evaluation of thermal insulation materials that may actively contribute to external stress corrosion cracking (ESCC) of austenitic stainless steel due to soluble chlorides within the insulation. It should be understood that this laboratory procedure is not intended to cover all of the possible field conditions that might contribute to ESCC.

1.2 While the 1977 edition of this test method (Dana test) is applicable only to wicking-type insulations, the procedures in this edition are intended to be applicable to all insulating materials, including cements, some of which would disintegrate when tested in accordance with the 1977 edition. Wicking insulations are materials that wet through and through when partially (50 to 75 %) immersed in water for a short period of time (10 min or less).

1.3 These procedures are intended primarily as a preproduction test for qualification of the basic chemical composition of a particular manufacturer's product and are not intended to be routine tests for ongoing quality assurance or production lot compliance. Test Methods C 871, on the other hand, is used for confirmation of acceptable chemical properties of subsequent lots of insulation previously found acceptable by this test method.

1.4 The values stated in inch-pound units are to be regarded as the standard. The values given in parentheses are for information only.

1.5 *This standard does not purport to address all of the safety concerns, if any, associated with its use. It is the responsibility of the user of this standard to establish appropriate safety and health practices and determine the applicability of regulatory limitations prior to use.*

2. Referenced Documents

2.1 *ASTM Standards:*

¹ This test method is under the jurisdiction of ASTM Committee C-16 on Thermal Insulation and is the direct responsibility of Subcommittee C16.31 on Chemical and Physical Properties.

Current edition approved Nov. March 10, 1997; 2000. Published June 1998; May 2000. Originally published as C 692 – 71. Last previous edition C 692 – 95a7.

- A 240/A 240M Specification for Heat-Resisting Chromium and Chromium-Nickel Stainless Steel Plate, Sheet, and Strip for Pressure Vessels²
- A 370 Test Methods and Definitions for Mechanical Testing of Steel Products²
- C 795 Specification for Thermal Insulation for Use in Contact with Austenitic Stainless Steel³
- C 871 Test Methods for Chemical Analysis of Thermal Insulation Materials for Leachable Chloride, Fluoride, Silicate, and Sodium Ions³
- G 30 Practice for Making and Using U-Bend Stress Corrosion Test Specimens⁴

3. Summary of Test Method

3.1 The procedures in this test method consist of using a specimen of insulation to conduct distilled (or deionized) water by wicking or dripping to an outside surface, through the insulation, to a hot inner surface of stressed Type 304 stainless steel for a period of 28 days. If leachable chlorides are present, they are carried along with the water and concentrated at the hot surface by evaporation in much the same way as has been experienced in actual industrial process situations.

3.2 Exposed stainless steel coupons are examined visually, and under 10× to 30× magnification, if necessary, to detect ESCC after the prescribed period of exposure.

4. Significance and Use

4.1 An inherent characteristic of some alloys of austenitic stainless steel is their tendency to crack at stress points when exposed to certain corrosive environments. The mechanisms of ESCC are complex and not completely understood but are apparently related to certain metallurgical properties. Chloride ions concentrated at a stress point will catalyze crack formation. It has been reported that other halide ions do not promote ESCC to the same degree as does chloride using the test technology of Test Method C 692 (drip test).⁵

4.2 Chlorides are common to many environments, so great care shall be taken to protect austenitic stainless steel from chloride contamination.

4.3 Most thermal insulations will not, of themselves, cause stress corrosion cracking as may be shown by tests. When exposed to elevated-temperature (boiling point range), environments containing chlorides, moisture, and oxygen, however, insulation systems may act as collecting media, transmigrating and concentrating chlorides on heated stainless steel surfaces. If moisture is not present, the chloride salts cannot migrate, and stress corrosion cracking because of chloride-contaminated insulation cannot take place.

4.4 Insulations may also be specially formulated to inhibit stress corrosion cracking in the presence of chlorides through modifications in basic composition or incorporation of certain chemical additives.

4.5 The ability of the 28-day test to measure the corrosion potential of insulation materials is documented by Karnes,⁶ whose data appear to have been used for construction of the acceptability curve used in Specification C 795 and other specifications.

4.6 The metal for all of the coupons used in this test method (C 692) shall be qualified (see Section 13) to ascertain that under conditions of the test, chloride ions will cause the metal to crack, and deionized water alone will not cause cracks.

5. Applicability (see also Section 10.2)

5.1 While the original test procedure for the 1977 edition of this test method (Dana Test) was limited to “wicking-type insulations,” the “drip test procedure” given in this edition can be used for all insulations that can be cut or formed into the required test specimen.

5.2 Heat treatment at some temperature (as recommended by the manufacturer) up to the maximum use temperature may be necessary to make the insulating material “wick,” and thus testable by either insulation test procedure (see Sections 11 and 12).

5.3 If the test insulation cannot be made to wick in any way (such as in the case of organic or inorganic closed-cell foams), or when a component of the insulation (such as an attached exterior jacket material) would be heated beyond the manufacturer's recommended temperature for the exterior component, then the 1½-in. (38-mm) wide test specimen may be sliced into two ¾-in. (19-mm) thick segments. When the two halves are held together with wire, pins, or a rubber band, they may be tested by dripping into the crack between the two halves, thus simulating the situation where water penetrates the junction between two sections of insulation. It may be necessary to wet the mating faces on the two half sections in order to make water wick down to the coupon surface.

5.4 Adhesives can be tested by gluing together a test block of the insulation material to be used with the adhesive. The adhesive joint must come into contact with the stainless steel test coupon.

5.5 Cements with a clay binder may be tested by casting a 1½-in. (38-mm) thick slab, drying, and using the drip procedure. Such a sample will disintegrate in the Dana test procedure.

² *Annual Book of ASTM Standards*, Vol 01.03.

³ *Annual Book of ASTM Standards*, Vol 04.06.

⁴ *Annual Book of ASTM Standards*, Vol 03.02.

⁵ Private communication from authors of paper presented at Bal Harbour ASTM C-16 Symposium on December 9, 1987. Whitaker, T. E., Whorlow, Kenneth M., and Hutto, Francis B., Jr., “New Developments in Test Technology for ASTM C692.”

⁶ Karnes, H. F., “The Corrosion Potential of Wetted Thermal Insulation,” AICHE, 57th National Meeting, Minneapolis, MN, September 26 through 29, 1965.

5.6 The drip procedure might also be extended to the testing of coatings applied to the coupon prior to test. The corrosive liquids dripped into such a system would be limited only by the imagination of the researcher.

6. Apparatus for Dana Test Procedure

6.1 *Enclosure*—The test apparatus may be located in a cabinet or other closed structure provided with a blower to maintain a positive internal pressure, and it may be equipped with a filter for intake air to minimize dust or other contamination. The test apparatus may also be housed in any suitable clean environment not subject to chloride contamination. The enclosure shall not be so tight as to exclude oxygen from the system, since oxygen is necessary for ESCC to occur.

6.2 Pyrex Glass Wool,⁷

6.3 “Cookie Cutter,” made from 1¼ in. (32 mm) thin wall electrical conduit (inside diameter 1.38 in. (35 mm)) to cut a 1⅜-in. (35-mm) diameter plug from 2-in. (51-mm) Pyrex Glass Wool.⁷

6.4 *Specimen Holder*, as shown in Fig. 1, or equivalent.

6.5 *Precision Bender*, see Practice G 30.

6.6 *Wet-Grinding Belt Grinder*, 80-grit.

6.7 *Copper Lugs*, commercial 2/0–4/0 solderless, or 2 by ½ by ⅛ in. (51 by 13 by 3.2 mm) copper tabs.

6.8 *Silver Solder*, and chloride-free flux for use with stainless steel.

6.9 *Torch*, acetylene or propane.

6.10 *Bolt*, stainless steel, ⅜ in. (5 mm) in diameter and 2½-in. (65-mm) long with insulating washer and nut for electrically insulating the bolt from the U-bend specimen.

6.11 *Hand-held Magnifier*, 10× or 30× binocular microscope, or both.

6.12 *Band Saw*.

6.13 *Hole Saw*, 2-in. (51-mm) outside diameter (optional).

6.14 *Crystallizing Dish*, of borosilicate glass, 7½ in. (190 mm) in diameter by 4 in. (100 mm) in depth, or stainless steel pan 9½ by 5½ by 4 in. (41 by 140 by 102 mm) deep.

6.15 *Electrical Transformer*, isolation-type. (approximately 150 mV/150 AMP).

6.16 *Thermocouple*, 28 gage or smaller.

6.17 *Epoxy Adhesive*, aluminum filled, (Metalset A4⁸ or equivalent).

6.18 *Drill Bit*, ⅜-in. (7-mm), cobalt steel preferred.

6.19 *Dye Penetrant and Developer*, available at most welding supply houses.

7. Apparatus for Drip Test Procedure

7.1 *Steam Heated Pipe*—A 5-ft (1.5-m) section of 1½ in. IPS pipe (inconel or other corrosion-resistant material is recommended) is suggested, heated either by a small self-contained steam boiler or by regulated house steam.

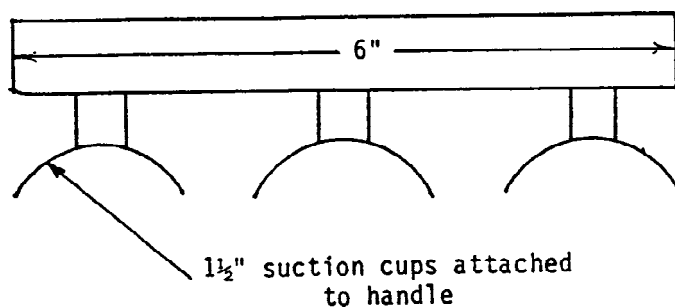

FIG. 1 Suction Cup Coupon Holder

7.2 *Peristaltic Pump*—A multichannel peristaltic pump is recommended to supply 250 (±25) mL/day to each specimen.

7.3 *I.V. Bottles*, 1 L or equivalent, to individually supply each test specimen with test liquid.

7.4 *Specimen Holder*, for grinding. See Fig. 1.

7.5 *Precision Bender*, see Fig. 2 in the 1979 edition of Practice G 30.

7.6 *Wet-Sanding Belt Sander*, with 80 grit belt.

7.7 *Bolt*, stainless steel, ⅜ in. (5 mm) in diameter by 2½-in. (65-mm) long with nut.

7.8 *Hole Saw*, 2-in. (51-mm) outside diameter.

7.9 *Band Saw*.

7.10 *Thermocouple*, 28 gage or smaller.

⁷ Available from lab supply houses.

⁸ Available from Smooth-On, Inc., 1000 Valley Road, Gillette, NJ 07933.

7.11 *Heat Transfer Grease*, chloride free.

7.12 *Kimwipe Tissue*,⁹ chloride free.

8. Reagents and Materials

8.1 *Distilled or Deionized Water*, containing less than 0.1 ppm chloride ions.

8.2 *Distilled or Deionized Water*, containing 1500 ppm chloride ion (2.473 g NaCl/L).

8.3 *Type 304 Stainless Steel Sheet*— 16 gage, meeting the composition requirements of Specification A 240. Certificates of chemical composition and mechanical properties, including ultimate tensile strength and yield strength by the 0.2 % offset method are required. Type 304 stainless steel meeting Specification A 240 shall have a carbon content in the range of 0.05–0.06 % and shall be solution-annealed.



FIG. 2 Typical External Stress Corrosion Cracks (5× Magnification)

9. Test Coupons

9.1 Shear 2 by 7-in. (51 by 178-mm) coupons from 16-gage Type 304 stainless sheet, as specified in 8.3, with the long dimension parallel to the long dimension of the sheet. (Long dimension parallel to sheet-rolling direction.)

9.2 Clean coupons with chloride-free liquid soap and water to remove any grease or other contamination.

9.3 Sensitize all coupons before bending by heating at 1200°F (649°C) in an argon (inert) or air (oxidizing) atmosphere for three hours. Let cool in the furnace after the sensitizing period.¹⁰ Temperature of the coupons must be measured in the stack of coupons, not in the furnace itself, as the coupon temperatures “lag” the furnace temperature by at least 50 to 100°F (28 to 56°C).

9.4 A suggestion for sensitizing in an inert atmosphere is to use a stainless steel box with a tight-fitting cover to contain the argon around the coupons during sensitization.

9.5 Grip coupon with suction cup holder (see Fig. 1) or other means to facilitate wet grinding on an 80-grit belt grinder. Grind parallel to the long dimension of the coupon using an 80-grit wet belt with just enough pressure to remove the dull finish and leave the metal bright. Do not overgrind. The beltground face is the test surface to be exposed to the thermal insulation. The test area is the bent coupon surface which actually comes into contact with the insulation.

9.6 Smooth and round sheared edges to prevent accidental cutting of fingers.

9.7 Bend each ground coupon to a 1.00 ± 0.01 -in. (25.4 ± 0.25 -mm) outside radius using a roll bender as shown in Fig. 5 of the 1979 edition of Practice G 30 to produce a U-shape in which the “legs” are parallel to within $1/16$ in. (1.6 mm).

9.8 Drill or punch a $3/32$ -in. (7-mm) hole in each end using the special jig shown in Fig. 3. The use of cobalt steel drill bits is highly recommended on 304 stainless steel as other bits dull quickly.

9.9 For the Dana test only, silver-solder a 2/0–4/0 solderless copper electrical connector to each leg with the hole in the connector centered on the drilled hole. While it has been conventional to solder one lug to an inside surface and the second to an outside surface, it is acceptable to solder both to outside surfaces for greater convenience. The body of the coupon should be shielded from high soldering temperatures by placing a soaking-wet chloride-free cellulose pad on the coupon next to the weld area to act as a heat sink. Carefully remove all flux from the finished coupon by washing with hot water. The contact surfaces of the copper connector should be cleaned by sanding, wire brush, or other means to avoid electrical contact problems.

⁹ Kimwipe is a trademarked product of Kimberly-Clark Corp., Roswell, GA.

¹⁰ For a discussion of the effect of sensitizing stainless steel and its susceptibility to stress corrosion, refer to “Stress-Corrosion Cracking of Sensitized Stainless Steel in Oxygenated High Temperature Water,” Batelle Columbus Laboratories, Report No. BMI 1927, June 1972.

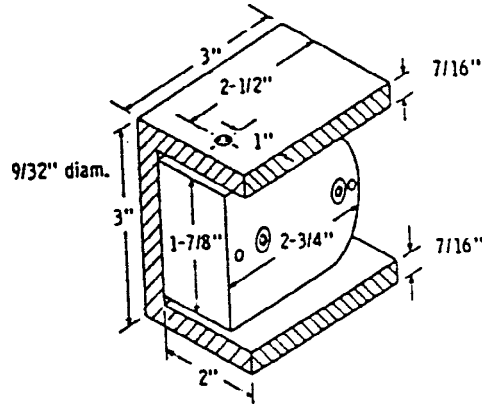

FIG. 3 Jig for Positioning Holes in the U-Bend Specimen

9.9.1 As an alternate to the 2/0-4/0 solderless lug, 2 by 1/2 by 1/8-in. (50.8 by 13 by 3.2-mm) copper lugs may be silversoldered to diagonally opposite outside corners leaving exactly half of each sticking out from the test coupon for the electrical hookup. Test data have shown this simpler lug to be equivalent to the commercial 2/0-4/0 lug.

9.10 Clean the convex surface to be tested with chloride-free cleansing powder and a cotton swab or chloride-free cellulose pad (such as Kimwipe⁹ or equivalent) soaked in distilled or deionized water. Rinse in distilled or deionized water, and air dry. Do not touch the convex test surface with bare hands thereafter.

9.11 Obtain the value of the yield strength and the modulus of elasticity from the certified statement of mechanical properties for the particular sheet of stainless steel or from tensile tests conducted in accordance with Test Methods and Definitions A 370. Make the necessary measurements on each test specimen and calculate the leg deflection required to produce the desired elastic stress using the formula shown in Fig. 4. The desired elastic stress for this test method is 30 000 psi.

9.12 Utilizing the value for sigma determined in 9.11, calculate the number of turns of the nut necessary to achieve the proper stress by dividing sigma by the distance between threads. The leg deflection may also be measured using a Vernier caliper.

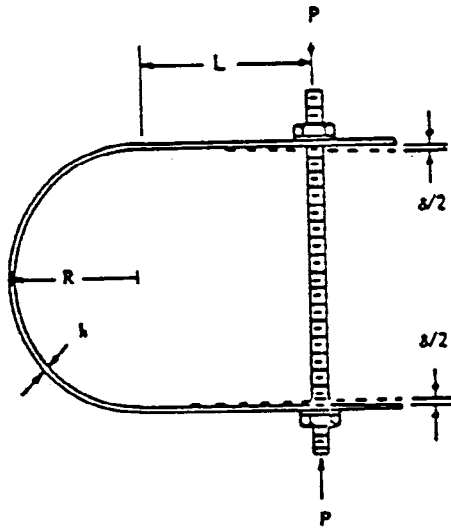

$$\delta \text{ in.} = \left[\frac{12S(2R + h)}{(L + R)(8R + h)(E)} \right] \cdot \left[\frac{L^3}{3} + R \left(\frac{\pi}{2} L^2 + \frac{\pi}{4} R^2 + 2LR \right) \right]$$

where:

- delta = deflection, in.,
- S = applied stress, psi,
- E = modulus of elasticity,
- R = radius of bend, in.,
- h = thickness, in., and
- L = length of straight section, in.

FIG. 4 Measurements Required for Post-Tensioning Deflection Calculations on U-Bend Test Specimens

- 9.13 Install bolt and nut (and washer for Dana test) on each coupon and run the nut up snug without bending the coupon.
- 9.14 Holding the head of the screw with a screwdriver, turn the nut the required number of turns as calculated in 9.12.
- 9.15 For the Dana test only, as a last step before running the test, attach a 28-gage (or smaller) thermocouple to the inside middle of the coupon using aluminum-filled epoxy. The head of the thermocouple should be in contact with the coupon to get an accurate measure of coupon temperature.
- 9.16 Before use, the lot of sensitized coupons shall be qualified using the procedure described in Section 13.

10. Sample Preparation

10.1 If there is any reason to believe that the surface of an insulating material might be different from the interior, the material shall be tested in such a manner as to test what is judged to be the most sensitive portion.

10.2 Procedure for materials in which the surfaces and interior may be considered totally uniform in properties, including but not limited to foam insulation cut from "buns," Foamlas, loose-fill insulation, man-made mineral-fiber block and board, and perlite insulation:

10.2.1 Cut insulation specimens into 4 by 7 by 1½-in. (102 by 178 by 38-mm) sections and drill a 2-in.(51-mm) hole in the center of each with an appropriate hole saw. Cut the specimen in half to produce two test specimens that measure 4 by 3½ by 1½ in. (102 by 89 by 38 mm) as shown in Fig. 5a.

10.2.2 Carefully fit each insulation block to its coupon by sanding with clean, chloride-free sandpaper if necessary to achieve a perfect fit. Air blow the prepared test specimen to remove dust which might contaminate the test surface.

10.2.3 Loose-fill materials may be tested by fabricating a "cage" from stainless steel wire mesh in the shape of the test specimen shown in Fig. 5a. Stuff the loose fill material into the cage at the intended use density.

10.2.4 Thin layers of insulating material may be tested by "stacking" to achieve a 1½-in. (38-mm) stack and then proceeding as directed in 10.2.1 above, holding the final test stack in place with a rubber band, wire, or straight pins.

10.3 Procedure for materials that may have outer surfaces that differ from inner surfaces, including but not limited to: (1) Wet-process materials where solubles may migrate to the outer surface during drying including calcium silicate and insulating cements. (2) Fiberglass that has been rolled on a mandrel to form pipe cover using a mandrel release agent. (3) Mineral wool which has been V-grooved and glued to form pipe cover.

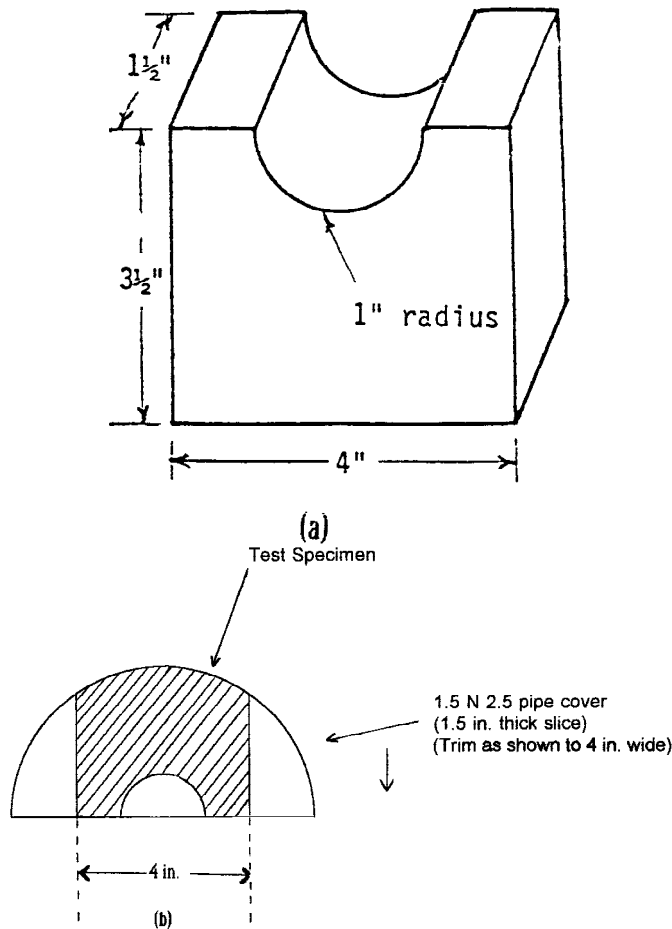

FIG. 5 Insulation Test Block Dimensions and Groove Location

10.3.1 Cut the test specimens from 1.5 N 2.5 pipe insulation, including jacketing (see the exception stated in 5.3) if it is attached to the insulation, as shown in Fig. 5b. Air blow the prepared test specimen to remove dust that might contaminate the test surface.

10.3.2 In the case of insulating cement, form the test piece around a bent coupon until set and then take out of the form for final drying. Since some cements do not readily wick water, samples made from such materials shall be split before testing to allow the DI water to penetrate down to the test coupon (Drip procedure only).

10.4 Choice of test procedure: (1) If the material readily wicks water, it may be tested by either the Dana or the Drip procedure. (2) If the material may be made to wick readily by heat treatment (for example, heating perlite insulation to destroy the hydrophobicity of the material) it may be tested by either test procedure. (See the exception stated in 5.3). (3) If the material cannot be made to wick, it shall be tested by the Drip procedure.

10.4.1 An unwettable block material may be split, with the two halves held together with a rubber band, pin, or wire for test. If the split surfaces cannot be wet in any way, they may be parted slightly to allow the DI water to penetrate down to the test coupon.

10.4.2 If the “stacked” material in 10.1.1.4 will not wick, it shall be tested by the Drip procedure, wetting or slightly separating the layers to allow the DI water to penetrate to the test coupon.

11. Test Procedure (Dana Test)

11.1 Place each specimen of thermal insulation in a crystallizing dish (or stainless steel alternate) with the Ushaped groove up, connect the stainless steel U-bend coupons electrically in series, and place in position within the cavity in the insulation specimen.

11.2 Fill the dish with water (see 8.1) to a level approximately ½ in. (13 mm) below the bottom of the concave cavity in the specimen. Before continuing the test, turn each sample on its side and allow it to completely wet before righting it to begin. Turn up the power to electrically heat the coupons to the local boiling point $\pm 10^{\circ}\text{F}$ ($\pm 6^{\circ}\text{C}$) range. Power setting should be in the 150 Mv/150 AMP range. This is the start of the 28-day test period.

11.3 Bring all of the coupons into line, according to temperature, by adjusting individual water levels. Raising the water level lowers the temperature. Lowering the water level raises the temperature.

11.4 Some sort of water level control shall be used on each test cell, individually. Otherwise, the coupon temperature rises as the liquid level drops and then falls when liquid is added, resulting in a cyclic pattern that continues for the duration of the test. The extent of the cyclic pattern depends on the amount the level is allowed to drop before refilling. If left unattended overnight, the temperatures can rise as much as 50 to 100°F (28 to 56°C). Water makeup per coupon should run in the 200 to 600 mL/day range, but a higher rate is acceptable. The test cell should not be covered to allow free access to oxygen that is necessary for the occurrence of ESCC.

11.5 At the conclusion of the test period (28-day ± 6 h), shut off the power and allow to cool. Disconnect the electrical leads and carefully remove the stainless steel coupons from the insulation specimens.

12. Test Procedure (Drip Test)

12.1 Place each coupon over the steam heated pipe with the stressed bend in the up position (tensioning bolt down) and a dab (about 1 cc) of chloride-free heat transfer grease between the coupon and the pipe. Keep the mating insulation test block at hand so that it can be properly paired up with its form-fit coupon.

12.1.1 If the coupons are bent exactly as specified, they snug up tightly to the pipe with the required post tensioning. With this perfect fit, no heat transfer grease or insulation sample fitting is necessary.

12.2 Reinstall post-stress bolt in accordance with 9.12-9.14.

12.3 Fill liquid reservoirs (see 7.3) with distilled or deionized water (see 8.1).

12.4 Start heated pipe (previously regulated to operate at boiling point + 10°F (+ 5.6°C) – 0°F (–0°C)).

12.5 Begin test time when pipe reaches operating temperature.

12.6 Start peristaltic pump (previously calibrated to deliver 250 mL/day to each sample block). Wet each sample block with test liquid from a wash bottle (or equivalent) until the block is visibly wet down to the coupon surface.

12.7 Monitor reservoir bottles daily to ascertain that the delivery to each sample is 250 \pm 25 mL/day. Refill every 3 days.

12.8 The temperature of the test coupons shall be maintained at the local boiling water temperature $\pm 10^{\circ}\text{F}$ ($\pm 6^{\circ}\text{C}$) as indicated by the temperature indicated on the hot pipe temperature monitor.

12.9 At the conclusion of the test period (28-day ± 6 h), carefully remove the stainless steel coupons from the insulation specimens. In the event of a power outage during the 28-day test, additional test time should be added to the end of the test to allow the delivery of the full amount of liquid to each coupon (28 \times 250 mL = 7000 mL).

13. Qualification of Sensitized Coupons for Use in Test Method

13.1 *Dana Test Procedure:*

13.1.1 Test four sensitized U-bend test coupons from each sensitized lot of stainless steel for stress cracking with a neutral wick in place of thermal insulation. The neutral wick shall consist of a plug of Pyrex Glass Wool (see 6.2) or demonstrated equivalent. The plug of wool shall be stood up “barrel fashion” in the evaporating dish with the coupon touching the top of the glass wool plug. The exposure period shall be 72 h \pm 30 min in a solution containing 1500 ppm of chemically pure chloride ion (2.473 g NaCl/L). The level of chloride solution in the dish shall be maintained between ¼ and ¾ in. (6.4 and 19 mm) below the coupon

to achieve test temperatures in the boiling point $\pm 10^{\circ}\text{F}$ ($\pm 6^{\circ}\text{C}$) range. Evaporation loss should be in the 250 to 1000 mL/day range.

13.1.2 All four coupons shall crack in order to qualify the lot of stainless steel for use in this test method.

13.1.3 Test four U-bend test coupons as a “blank” test in the same manner as 13.1.1 using deionized water for 28 days.

13.1.4 None of the four coupons should crack for the lot of metal to qualify for use in this test method.

13.2 Drip Test Procedure:

13.2.1 Each lot of stainless steel shall be qualified by testing four sensitized U-bend test coupons with a neutral wick in place of the thermal insulation. The neutral wick shall consist of a single layer of Kimwipe⁹ or equivalent placed on top of the test surface with the dripper set to discharge 250 mL/day of 1500 mg/L chloride solution to the center of the Kimwipe. The piece of Kimwipe shall measure 1.5 in. (38 mm) by 4 in. (100 mm) to allow an air-liquid interface at the edges of the salt accumulation. The cracking generally occurs on the edges of the Kimwipe; it almost never occurs in the center.

13.2.2 Install coupons on hot pipe as described in 12.1 and 12.2.

13.2.3 Start up hot pipe as in 12.5-12.7.

13.2.4 The exposure period shall be 72 h \pm 30 min with 1500 ppm chloride solution (see 8.2) at a drip rate of 250 \pm 25 mL/day.

13.2.5 Monitor as in 12.8 and 12.9.

13.2.6 Conclude the qualification test by stopping the flow of chloride solution and removing the coupons from the test pipe.

13.2.7 Inspect coupons as in 14.1-14.5.

13.2.8 All four specimens shall crack in order to qualify the lot of stainless steel for use in this test method.

13.2.9 Test four U-bend test coupons as a “blank” test in the same manner as 13.2.1-13.2.7 using deionized water for 28 days.

13.2.10 None of the four coupons should crack for the lot of metal to qualify for use in this test method.

14. Inspection of Coupons

14.1 Stress corrosion cracks are dendritic in shape and can go in any direction without regard to the geometry of the test coupon. Fig. 2 is an example of stress corrosion cracking.

14.2 Visually examine all test coupons (including all qualification coupons) under good lighting for evidence of ESCC. Personnel involved in the inspection shall demonstrate natural or corrected near distance vision acuity of 20/25 or greater Snellen fraction with at least one eye and be trained for ESCC detection. While not always the case, stress corrosion cracks are usually accompanied by brown or black iron corrosion products on the surface at the cracked area. If visual inspection shows ESCC to have occurred, no further examination is necessary. If no cracks are found, proceed with the inspection.

14.3 Manually flatten all coupons (including all qualification coupons). If there was significant accumulation of solids on the coupon, this rebending usually loosens most of the solids for easy removal by brushing with a coarse brush or pot scrubber. Insulation products containing an organic binder such as the phenolic binder in fiberglass or mineral wool may require additional cleaning. A spray-on oven cleaner is very helpful in removing such deposits.

14.4 Rebend all coupons (including all qualification coupons) using a pipe with a 2 in. (51 mm) outer diameter as a mandril to form roughly the original shape. After forming the original shape, remove the coupons from the mandril and bring the legs of all the coupons together until they touch momentarily. Very carefully examine the test surface of all cleaned and rebent coupons for any cracks using 10 to 30 \times magnification.

14.5 If cracks have not been detected up to this point, spray the test area with a liquid dye penetrant and developer (following the instructions of the manufacturer). Inspect for suspect areas, which will be indicated by the dye's showing through the developer. Mark the suspect areas, remove the developer, and reinspect under magnification.

14.6 If cracks have not been firmly established and part of the test area is still suspect because of dye penetrant indication, flatten the coupon and bend again as in 14.4, with the suspect area in the center of the bend. If present, cracks will open up. Pits and corroded areas will not crack. Final inspection shall be made with 30 \times magnification if cracks have not been established at lower magnification. If cracks have not been established after completing this inspection procedure, the test coupon is considered to be crack-free. Save the coupon as evidence for the final test report.

15. Report

15.1 Report the following information:

15.1.1 Test procedure used (Dana or Drip).

15.1.2 Name, density, and other identifying information for each insulation test specimen and the form of the specimen (block or pipe cover).

15.1.3 Information on heat treatment or other special treatment or provisions necessary to run the material.

15.1.4 Number of specimens tested,

15.1.5 Number and severity of cracks in the test area of each coupon and how they were found.

15.1.6 Chemical analysis data run in accord with Test Methods C 871. (Optional unless this test method being run to certify for Specification C 795, in which case the chemical tests are mandatory.)

15.1.7 Pictures or other evidence presented to support the presence of stress corrosion cracks in the test coupons (optional).

15.1.8 Information on metal carbon content and heat treatment conditions.

16. Precision and Bias

16.1 In 1994, results of an interlaboratory study were reported by four laboratories for a 28-day test of two samples (X and Y).

Each sample consisted of four coupons. Three of the laboratories used the Drip test; one laboratory the Dana test. One of the laboratories that used the Drip test ran two sets of samples. The results are summarized as follows: (1) for sample X, all laboratories reported zero failures (100 % agreement); (2) for sample Y, all tests showed failures (i.e, cracked coupons); and (3) the agreement among the four laboratories for number of failures was ± 1 .

17. Keywords

17.1 austenitic stainless steel; chloride; Dana test; Drip test; external stress corrosion cracking (ESCC); qualification test; thermal insulation; wicking insulation

ASTM International takes no position respecting the validity of any patent rights asserted in connection with any item mentioned in this standard. Users of this standard are expressly advised that determination of the validity of any such patent rights, and the risk of infringement of such rights, are entirely their own responsibility.

This standard is subject to revision at any time by the responsible technical committee and must be reviewed every five years and if not revised, either reapproved or withdrawn. Your comments are invited either for revision of this standard or for additional standards and should be addressed to ASTM International Headquarters. Your comments will receive careful consideration at a meeting of the responsible technical committee, which you may attend. If you feel that your comments have not received a fair hearing you should make your views known to the ASTM Committee on Standards, at the address shown below.

This standard is copyrighted by ASTM International, 100 Barr Harbor Drive, PO Box C700, West Conshohocken, PA 19428-2959, United States. Individual reprints (single or multiple copies) of this standard may be obtained by contacting ASTM at the above address or at 610-832-9585 (phone), 610-832-9555 (fax), or service@astm.org (e-mail); or through the ASTM website (www.astm.org).