



Designation: C 739 – 00<sup>ε1</sup>

## Standard Specification for Cellulosic Fiber (Wood-Base) Loose-Fill Thermal Insulation<sup>1</sup>

This standard is issued under the fixed designation C 739; the number immediately following the designation indicates the year of original adoption or, in the case of revision, the year of last revision. A number in parentheses indicates the year of last reapproval. A superscript epsilon ( $\epsilon$ ) indicates an editorial change since the last revision or reapproval.

*This standard has been approved for use by agencies of the Department of Defense.*

<sup>ε1</sup> NOTE—Section 10.1 was editorially revised in September 2001.

### 1. Scope

1.1 This specification covers the composition and physical requirements of chemically treated, recycled cellulosic fiber (wood-base) loose-fill type thermal insulation for use in attics or enclosed spaces in housing, and other framed buildings within the ambient temperature range from  $-45.6$  to  $82.2^{\circ}\text{C}$  ( $-50$  to  $180^{\circ}\text{F}$ ) by pneumatic or pouring application. While products that comply with this specification may be used in various constructions, they are adaptable primarily, but not exclusively, to wood joist, rafters, and stud construction.

1.2 The values stated in SI units are to be regarded as the standard. The values in parentheses are provided for information only.

1.3 *This standard does not purport to address all of the safety concerns, if any, associated with its use. It is the responsibility of the user of this standard to establish appropriate safety and health practices and determine the applicability of regulatory limitations prior to use.*

### 2. Referenced Documents

#### 2.1 ASTM Standards:

- B 152 Specification for Copper Sheet, Strip, Plate, and Rolled Bar<sup>2</sup>
- C 168 Terminology Relating to Thermal Insulating Materials<sup>3</sup>
- C 177 Test Method for Steady-State Heat Flux Measurements and Thermal Transmission Properties by Means of the Guarded-Hot-Plate Apparatus<sup>3</sup>
- C 236 Test Method for Steady-State Thermal Performance of Building Assemblies by Means of a Guarded Hot Box<sup>3</sup>
- C 518 Test Method for Steady-State Heat Flux Measurements and Thermal Transmission Properties by Means of the Heat Flow Meter Apparatus<sup>3</sup>
- C 687 Practice for Determination of Thermal Resistance of

#### Loose-Fill Building Insulation<sup>3</sup>

- C 1045 Practice for Calculating Thermal Transmission Properties from Steady-State Heat Flux Measurements<sup>3</sup>
- C 1114 Test Method for Steady-State Thermal Transmission Properties by Means of the Thin-Heater Apparatus<sup>3</sup>
- E 970 Test Method for Critical Radiant Flux of Exposed Attic Floor Insulation Using a Radiant Heat Energy Source<sup>4</sup>

### 3. Terminology

3.1 *Definitions*—For definitions of terms used in this specification, see Terminology C 168.

#### 3.2 Definitions of Terms Specific to This Standard:

3.2.1 *attic*—an enclosed space between the roof and ceiling of the occupied part of a building.

3.2.2 *critical radiant flux*—the level of incident radiant heat energy on the attic floor insulation system at the most distant flame-out point ( $\text{W}/\text{cm}^2$  ( $\text{Btu}/\text{ft}^2 \cdot \text{s}$ )).

### 4. Materials and Manufacture

4.1 The basic material shall be recycled wood-based cellulosic fiber made from selected paper, paperboard stock, or ground wood stock, excluding contaminated materials, which may reasonably be expected to be retained in the finished product. Suitable chemicals are introduced to provide properties such as flame resistance, processing, and handling characteristics.

4.2 The basic material may be processed into a form suitable for installation by pneumatic or pouring methods.

### 5. Physical and Chemical Properties

5.1 *Design Density*—The design density shall be determined in accordance with Section 8. Report all units in  $\text{kg}/\text{m}^3$  ( $\text{lb}/\text{ft}^3$ ).

5.1.1 Design density is not a basis for acceptance or rejection.

5.2 *Corrosiveness*—The loose-fill insulation material shall be tested for corrosiveness as specified in Section 9. The composition of the insulation material shall be such that after

<sup>1</sup> This specification is under the jurisdiction of ASTM Committee C-16 on Thermal Insulation and is the direct responsibility of Subcommittee C16.23 on Blanket and Loose Fill Insulation.

Current edition approved May 10, 2000. Published August 2000. Originally published as C 739 – 73. Last previous edition C 739 – 97.

<sup>2</sup> *Annual Book of ASTM Standards*, Vol 02.01.

<sup>3</sup> *Annual Book of ASTM Standards*, Vol 04.06.

<sup>4</sup> *Annual Book of ASTM Standards*, Vol 04.07.

testing, no perforation of the 3-mil (76- $\mu$ m) metal specimens shall be evident when the specimens are observed over a 40-W appliance light bulb. Notches extending into the coupon 3 mm or less from any edge shall be ignored.

5.3 *Critical Radiant Flux*—When tested in accordance with Section 10, the critical radiant flux shall be equal to greater than 0.12 W/cm<sup>2</sup> (0.11 Btu/ft<sup>2</sup>·s). All values shall be reported to two significant digits.

5.4 *Fungi Resistance*—The loose-fill insulation material shall be tested and shall pass fungi resistance as specified in Section 11. If the growth on two or more of the replicate test items is greater than that on the comparative item, the test item shall be considered to fail.

NOTE 1—If the manufacturing claims the insulation kills or controls insects or rodents, or both, the product must be registered as a pesticide under the Federal Insecticide, Fungicide and Rodenticide Act, as amended, and must also be registered in accordance with state pesticide statutes.

5.5 *Moisture Vapor Sorption*—Moisture gain in the insulation shall be no more than 15 % by weight when tested in accordance with Section 12.

5.6 *Odor Emission*—Any sample producing a detectable odor that is classified as objectionable and strong or very strong by more than two panel members shall be considered to have failed the test when tested in accordance with Section 13.

5.7 *Smoldering Combustion*—When tested in accordance with the smoldering combustion test method in Section 14, the insulation shall show no evidence of flaming and a weight loss no greater than 15 %.

5.8 *Thermal Resistance*—The standard thermal resistance values recommended for application shall be expressed in K·m<sup>2</sup>/W (°F·h·ft<sup>2</sup>/Btu). The thermal resistance *R* for the average of any (four) randomly selected samples shall not be more than 5 % below the listed *R* value when tested in accordance with Section 15. *R* values other than those listed shall be as agreed upon between the supplier and the purchaser.

## 6. Workmanship, Finish, and Appearance

6.1 The product shall be free of extraneous foreign materials such as metals and glass that will adversely affect the performance in service.

## TEST METHODS

### 7. Summary

7.1 The following test methods shall be conducted on loose-fill cellulosic insulation at the measured design density: corrosiveness, critical radiant flux, fungal growth, moisture absorption, odor emission, smoldering combustion, and thermal resistance.

NOTE 2—The importance of an insulation's product to maintain its fire retardant characteristics is recognized. A task group in ASTM C16.31 is currently studying methods to ascertain if there is a long-term deterioration of fire performance characteristics of cellulose insulation. Should the need for a permanency test be determined by this task group and a test method be developed and finalized, it will become a part of this specification.

### 8. Design Density

8.1 *Scope*—This test method provides a basis for calculating the product coverage values and for conducting physical

property tests requiring the use of design density for sample preparation.

8.2 *Significance and Use*—The design density is the approximate density expected after long-term attic application.

8.3 *Apparatus and Materials*:

8.3.1 *Insulation Specimen Container*—A beaker having a flat bottom and an inside diameter of 15.0 ± 1 cm (5.9 ± 0.39 in.), straight sides. The height of the beaker shall be such that the distance between the bottom of the cyclone and the top edge of the beaker is 8.50 ± 1.0 cm (3.35 ± 0.39 in.).

8.3.2 *Flat Rigid Disk*, having a total weight of 75 ± 5 g (2.65 ± 0.18 oz) and of a suitable diameter to fit loosely into the specimen container. Weight may be added to the center of the disk to bring the total weight to the required 75 ± 5 g.

8.3.3 *Balance*, having a 2-kg (4.41-lb) capacity accurate to ± 0.2 g (± 0.007 oz).

8.3.4 *Blower Apparatus*, having two blower units (supply and overflow) meeting the following specifications:

8.3.4.1 Each blower apparatus shall be capable of blowing an average of 272.2 kg (600 lb) of insulation per hour.

8.3.4.2 Each blower apparatus shall have a nominal air flow velocity of 0.38 m/s (75 ft/min).

8.3.4.3 Each blower apparatus shall have a nominal motor speed of 16 450 r/min at 115 V (a-c).

8.3.5 *Shaker Unit*, having a capability of shaking 4.5 kg (10 lb) of weight with a vertical motion of 0.5 g rms acceleration at an approximate frequency of 9 Hz and displacement of approximately 1.17 ± 0.08 cm (<sup>15</sup>/<sub>32</sub> ± <sup>1</sup>/<sub>32</sub> in.).

8.3.6 *Fill Chamber*, having inside dimensions of 45.7 cm (18 in.) high by 38.1 cm (15 in.) wide by 38.1 cm (15 in.) deep, with covered openings that will allow a radiant panel tray to be slid through the chamber (see Fig. 1).

8.3.7 *Cyclone Receiver*—See Fig. 2.

8.3.8 *Hose*—Various lengths of nominal 5.08-cm (2-in.) diameter hose (see Fig. 1):

8.3.8.1 *Supply Source Hose*, 274.3 ± 5.1 cm (108 ± 2 in.).

8.3.8.2 *Cyclone Receiver Hose*, 182.9 ± 5.1 cm (72 ± 2 in.).

8.3.8.3 *Fill Chamber Exit Hose*, 91.4 ± 5.1 cm (36 ± 2 in.).

8.3.8.4 *Overflow Exhaust Hose*, length as needed.

8.3.9 *Blower Controls*, having capability of operating the two blowers at 40 V rms and 12 A.

8.3.10 *Insulation Holding Container*, capable of holding four times the amount of insulation required to fill the specimen container.

8.3.11 *Garden Rake*, with steel teeth.

8.4 *Conditioning*:

8.4.1 Condition specimens to equilibrium at 21 ± 2.0°C (69.8 ± 3.6°F) and 50 ± 5 % relative humidity in an open top mesh bottom container not exceeding 10.16 cm (4 in.) in depth and position in such a way to allow free movement of air on exposed sides. A change in net weight of the specimen that is less than 1 % in two consecutive weighings with 24 h between each weighing constitutes equilibrium.

8.4.2 If ambient laboratory conditions are different from the conditioning requirements specified in 8.4.1, begin testing the specimen for design density within 10 min after it has been removed from the conditioned area.

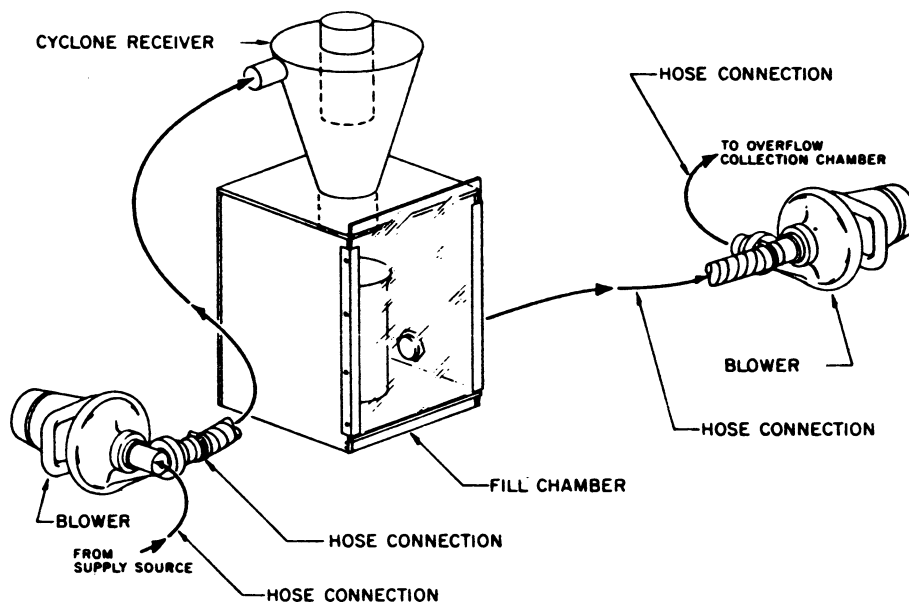

FIG. 1 Partial Insulation Preparation Apparatus

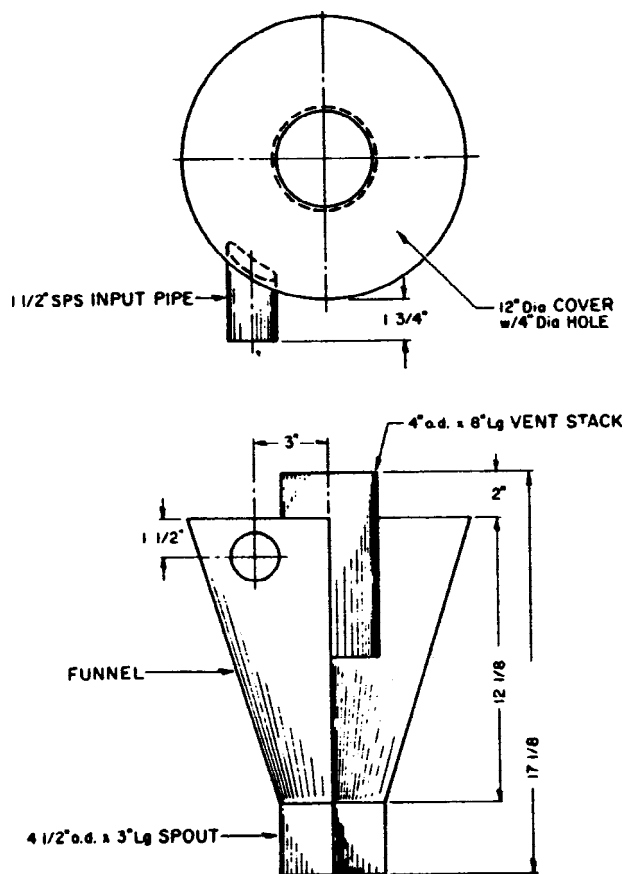

FIG. 2 Cyclone Receiver Weldment

8.5 Procedure for Pneumatic Applications:

8.5.1 Conduct the test in an area conditioned in accordance with 8.4.1.

8.5.2 Blow the material through a commercial blower using 30.48 m (100 ft.) of 5.08 cm (2 in.) hose into a sample receiver while holding the hose horizontally at a height of four feet.

8.5.3 Set up the apparatus as shown in Fig. 1. Connect one end of the supply source hose to the intake of the supply blower. Use the other end of the supply source hose to pick up insulation from the holding container. Connect one end of the cyclone receiver hose to the outlet of the supply blower and the other end to the fill chamber. Place the fill chamber on a flat and level surface. Connect one end of the variable length overflow exhaust hose to the outlet of the overflow blower. Conveniently place the other end to reduce insulation dust in the test area.

8.5.4 Weigh the empty insulation specimen container and record its weight.

8.5.5 Place the empty insulation specimen container in the fill chamber, centered under the cyclone receiver, and close the front cover.

8.5.6 Adjust the blower control(s) so that the supply and overflow blowers will operate at a no-load voltage of 40 V rms.

8.5.7 Simultaneously turn on the blowers and proceed to fill the insulation specimen container by picking up material from the holding container using the supply source hose.

8.5.8 The container may fill unevenly, that is, a void may tend to form off center in the container. If this occurs, stop the blowing process and rotate the container. If, for any reason, the filling process is interrupted for more than 1 min or for more than the time allowed to rotate the container once, begin the process again.

8.5.9 Gently remove the excess material using a straight edge to leave a uniform surface on the insulation flush with the top of the container.

8.5.10 Weigh the filled and leveled container and record the weight. Take care not to bump or jar the container so not to introduce any extraneous settling of the insulation.

8.5.11 Cover the container to prevent spilling and secure the container to the shaker. Operate the shaker for a period of 5 min ± 15 s.

8.5.12 Remove the container from the shaker and uncover, taking care not to bump or jar it. Lower the disk very slowly

into the container until it starts to contact the insulation. At this point, release the disk and allow it to settle onto the insulation under its own weight.

8.5.13 Measure the volume of the space occupied by the insulation using the bottom edge of the disk as the upper datum point. If the disk is not level, measure the high and low points of the bottom of the disk and average the readings and use this as the height measurement in calculating the volume ( $V_s$ ). Calculate the design density using the insulation volume and insulation mass ( $W$ ).

8.5.14 Repeat 8.5.1-8.5.13 using another specimen of the insulation until four densities are obtained for a given material. Then average these figures to determine the design density.

**8.6 Procedure for Pouring Applications:**

8.6.1 Pour loose-fill insulation into a simulated attic space until full. The attic space shall be formed by two nominal 2 by 6 by 8-ft long joists placed 40.6 cm (16 in.) on center with 1.27-cm (1/2-in.) plywood nailed to the ends and bottom. Fluff the material with a garden rake, applying a series of small amplitude strokes while moving the rake slowly along the joist. Repeat the fluffing process six times.

8.6.2 Weigh the empty insulation specimen container and record its mass.

8.6.3 Using a shovel, remove the insulation from the simulated attic space and place it into the specimen container until the container just begins to overflow.

8.6.4 Follow the procedure specified in 8.5.9-8.5.13.

8.6.5 Repeat 8.6.2-8.6.4 using another specimen of the insulation until four densities are obtained for a given material. Then average these values to determine the design density.

**8.7 Procedure for Pouring and Pneumatic Applications—**If the insulation is intended for both pouring and pneumatic applications, or if it is uncertain whether the insulation will be poured or installed pneumatically, test the insulation for design density in accordance with 8.4, 8.5, and 8.6 for each of the applications.

8.8 **Calculations—**Calculate the design density, in kg/m<sup>3</sup> (lb/ft<sup>3</sup>), of each specimen using Eq 1:

$$\text{Design density} = W/V_s \quad (1)$$

where:

$W$  = combined mass of the container and insulation minus the mass of the container, g, and

$V_s$  = volume of insulation in container after shaking, L.

**8.9 Precision and Bias—**

8.9.1 **Precision<sup>5</sup>**—The precision of this test method was determined from a report published in the Federal Register, March 8, 1979. Seven laboratories participated in an interlaboratory test program designed to determine the repeatability and reproducibility of the proposed CPSC settled density test for cellulosic loose fill insulation. Each laboratory conducted the settled density test on seven different cellulosic loose fill insulation materials. Four replicate tests were run on each sample. Table 1 shows an estimate of precision based on the interlaboratory tests. The results for two materials, cotton and groundwood, are not included.

**TABLE 1 Precision for Cellulose Insulation**

5 spec., 7 labs, 4 replicates	Avg. (PCF)	Repeatability/ % Mean	Reproducibility/ % Mean
Sample N	3.06	r = 0.211020/6.90 %	R = 0.847863/27.74 %
Sample K	3.20	r = 0.261434/8.26 %	R = 0.741396/23.15 %
Sample L	3.29	r = 0.203637/6.18 %	R = 0.901550/27.37 %
Sample Q	3.50	r = 0.288375/8.25 %	R = 0.429642/12.29 %
Sample M	3.88	r = 0.272431/7.02 %	R = 1.053352/27.14 %

8.9.2 **Bias**—No information can be presented on the bias of this test method because no materials having an accepted reference value are available.

**9. Corrosiveness**

9.1 **Scope**—This test method covers the determination of the corrosiveness of cellulosic insulation. The cellulosic insulation shall be tested for corrosiveness using the measured design density, as determined in Section 8. The pass/fail criteria is given in 5.2.

9.2 **Significance and Use**—This test method provides a basis for estimating the corrosiveness of cellulosic insulation in contact with steel, copper, and aluminum test materials. The test method represents one set of exposure conditions designed to accelerate possible corrosive effects, and may not simulate exposure conditions experienced in actual field applications.

**9.3 Apparatus and Materials:**

9.3.1 **Humidity Chamber (Test Method A)**, air-circulating, capable of maintaining a temperature of 48.9 ± 1.7°C (120 ± 3°F) and 97 ± 1.5 % relative humidity throughout the active portion of the chamber.

9.3.2 **Oven (Test Method B)**, air circulating, capable of maintaining a temperature of 48.9 ± 1.7°C (120 ± 3°F) throughout the active portion of the chamber.

9.3.3 **Crystallizing Dishes**, six, glass, 90 mm (3.54 in.) in diameter by 50 mm (1.97 in.) in height.

9.3.4 **Containers**, six, glass, polyethylene or polypropylene, with screw cap or friction top lid capable of sealing, 127 mm (5 in.) in nominal diameter and 76 mm (3 in.) in nominal height.

9.3.5 **Gloves**, clean and in good condition.

9.3.6 **Chemicals**—Reagent-grade chemicals shall be used in all tests. Unless otherwise indicated, it is intended that all reagents shall conform to the specifications of the Committee on Analytical Reagents of the American Chemical Society, where such specifications are available.<sup>6</sup>

9.3.7 **Water**, sterile and either distilled or deionized.

9.3.8 **Forceps**.

9.3.9 **Test Coupons:**

9.3.9.1 Two, 3003 Bare Aluminum alloy, zero temper.

9.3.9.2 Two, Specification B 152, Type ETP, Cabra No. 110 soft copper.

9.3.9.3 Two, low-carbon, commercial quality, cold-rolled, less than 0.30 % carbon, shim steel.

<sup>6</sup> *Reagent Chemicals, American Chemical Society Specifications*, American Chemical Society, Washington, DC. For suggestions on the testing of reagents not listed by the American Chemical Society, see *Analar Standards for Laboratory Chemicals*, BDH Ltd., Poole, Dorset, U.K., and the *United States Pharmacopeia and National Formulary*, U.S. Pharmacopeial Convention, Inc. (USPC), Rockville, MD.

<sup>5</sup> A technical report on the interlaboratory test series is available from ASTM.

9.3.9.4 Each coupon shall be 50.8 by 50.8 by 0.076-mm (2 by 2 by 0.003-in.) thick, free of tears, punctures, or crimps. Six coupons shall be used for one test of the insulation.

9.4 *Sampling*—Samples of cellulose insulation used for testing shall be blown, combed, or otherwise mixed to reasonably ensure homogeneity of the sample.

9.5 *Procedure:*

9.5.1 *Precleaning Metal Coupons:*

9.5.1.1 During fabrication, cleaning, or testing, never touch the metal coupons by ungloved hands.

9.5.1.2 Handle cleaned coupons with only clean forceps.

9.5.1.3 In order to avoid exposing laboratory personnel to toxic fumes, perform all cleaning in a fume hood.

9.5.1.4 Clean the coupons by vapor degreasing with 1-1-1 trichloroethane for 10 min. Following vapor degreasing, subject the coupons to caustic or detergent washing, or both, as appropriate. Following caustic or detergent washing, rinse the coupons in flowing water to remove residues. Inspect each coupon for a water-break free surface. (A water-break is a break, separation, beading, or retraction of the water film as the coupon is held vertically after wetting.) As the coupons are cleaned, the water film should become gradually thinner at the top and heavier at the bottom. Hot-air dry the coupons at 105°C (221°F).

9.5.2 *Preparation of Test Samples:*

9.5.2.1 Determine the design density of the sample in accordance with Section 8.

9.5.2.2 For each metal coupon, subdivide a 20-g (0.7-oz) sample of insulation into two 10-g (0.35-oz) portions. Determine the quantity of sterile and either distilled or deionized water to be used for each 10-g (0.35-oz) portion in accordance with Eq 2:

$$\frac{2.9}{d} \times 75 \text{ mL} \quad (2)$$

where  $d$  = design density, lb/ft<sup>3</sup>.

9.5.2.3 Presaturate each 10-g (0.35-oz) portion with the determined amount of water. Place one presaturated 10-g (0.35-oz) portion into a crystallizing dish, tamp level using the bottom of a clean suitably sized glass beaker. Place a metal coupon onto the presaturated insulation portion and center it in a horizontal plane. Place the other presaturated 10-g (0.35-oz) portion into the crystallizing dish on the metal coupon and tamp the composite specimen (metal coupon and saturated insulation in the crystallizing dish) to ensure an even distribution of this material and to ensure good contact of the insulation with the metal. Exercise care in preparing the composite specimens to eliminate air pockets from forming next to the metal coupons.

9.5.2.4 Do not cover the crystallizing dish. Care should be taken to avoid evaporation from the composite during preparation or until it is placed on the testing chamber.

9.5.3 *Sample Test Cycle*—Use either a humidity chamber (Method A) or an oven (Method B) to provide the required temperature and relative humidity exposure.

9.5.3.1 *Test Method A*—Test Method A is given to be consistent with federal standards and Test Method B is given as an alternative since the 97 ± 1.5 % relative humidity is an alternative requirement.

(a) Precondition the humidity chamber to 48.9 ± 1.7°C (120 ± 3°F) and 97 ± 1.5 % relative humidity.

(b) Place all six composite samples in the humidity chamber. Keep the samples in the humidity chamber 336 ± 4 h. During the test cycle, periodically monitor the temperature and humidity.

(c) During the test cycle, do not open the humidity chamber unless it can be determined that such openings do not adversely affect the test cycle.

(d) If drippings of condensate occurs within the humidity chamber, position guards over the samples to prevent the condensate from falling onto the samples.

9.5.3.2 *Test Method B:*

(a) Precondition the oven to 48.9 ± 1.7°C (120 ± 3°F).

(b) Place the crystallizing dishes containing the composite sample in separate 127-mm (5-in.) diameter containers.

(c) Add 70 mL of sterile and either distilled or deionized water solution plus 25 g (0.88 oz) of potassium sulfate to the annular space between the crystallizing dish and the container. Use care not to add any of the solution to the composite sample. If any of the solution is inadvertently added to the composite sample, prepare a new composite.

(d) Loosely place the covers on the containers and preheat the containers 1 h in the oven at 48.9 ± 1.7°C (120 ± 3°F). After preheating, seal the containers by tightening the covers. Keep the containers in the oven 336 ± 4 h. During the test cycle, periodically monitor the temperature.

(e) During the test cycle, do not open the oven unless it can be determined that opening does not adversely affect the test cycle.

9.5.4 *Post-Test Cleaning of the Metal Coupons*—After completing the test cycle, disassemble the composite specimens. Thoroughly wash the metal coupons under running water and lightly brush them using a soft nylon bristle brush or equivalent to remove loose corrosion products. Remove the remaining corrosion products from the metal coupons by cleaning them as follows in a fume hood:

9.5.4.1 *Technique No. 1—Electrolytic Cleaning* (for copper, steel, and aluminum coupons). Electrolyze the coupons by making a solution containing 28 mL of sulfuric acid (sp gr 1.84), 2 mL of organic inhibitor (for example, about 0.5 g/L of such inhibitors as diorthotolyl thiourea, quinoline ethiodide, or betanaphthol quinoline) and 970 mL water. Maintain the solution at 75°C (167°F). Use carbon or lead for the anode and one metal coupon for the cathode. Electrolyze for 3 min at a current density of 20 A/cm<sup>2</sup>. See Note 3 and Note 4.

NOTE 3—If using lead anodes, lead may deposit on the coupon. If the coupon is resistant to nitric acid, remove the lead by a flash dip in a solution of equal parts nitric acid and water.

NOTE 4—To avoid injury when mixing acid and water, for electrolytic cleaning gradually pour the acid into the water with continuous stirring, and provide cooling if necessary.

9.5.4.2 *Technique No. 2—Copper* (This technique or Technique No. 1 may be used for postcleaning only the tested copper coupons.) Make a solution containing 500 mL of hydrochloric acid (sp gr 1.19), 100 mL of sulfuric acid (sp gr 1.84), and 400 mL of water. See Note 5.

NOTE 5—To avoid injury, prepare the solution by slowly adding the

sulfuric acid to the water with continuous stirring. Cool, then add the hydrochloric acid slowly with continuous stirring. The solution shall be at room temperature. Dip the coupons in the solution for 1 to 3 min.

9.5.4.3 *Technique No. 3—Steel* (This technique or Technique No. 1 may be used for postcleaning only the tested steel coupons.) Use one of the following two solutions:

(a) *Solution No. 1*—Add 100 mL of sulfuric acid (sp gr 1.84), 1.5 mL organic inhibitor, and water to make a 1-L solution. Maintain the solution at  $50 \pm 2^\circ\text{C}$  ( $120 \pm 3.6^\circ\text{F}$ ). Dip the coupons in this solution.

(b) *Solution No. 2* (Clarke’s solution)—Add 20 g (0.71 oz) of antimony trioxide and 50 g (1.76 oz) of stannous chloride to 1 L of hydrochloric acid (sp gr 1.19). Stir the solution and use it at room temperature. Dip the coupons for up to 25 min in this solution, while stirring the solution at a rate so that deformation of the coupons does not occur.

9.5.4.4 *Technique No. 4—Aluminum* (This technique or Technique No. 1 can be used for postcleaning only the tested aluminum coupons.) Make a 1-L solution by adding 20 g (0.71 oz) of chromic acid and 50 mL of phosphoric acid (sp gr 1.69) to water. Maintain the solution at  $80 \pm 2^\circ\text{C}$  ( $176 \pm 3.6^\circ\text{F}$ ). Dip the coupons in this for 5 to 10 min. If a film remains, dip the coupons in nitric acid (sp gr 1.42) for 1 min. Repeat the chromic acid dip. If there are no deposits, use nitric acid alone.

9.5.5 *Inspection*—After cleaning the metal coupons, examine the coupons over a 40-W light bulb for perforations. Ignore notches that extend into the coupon 3 mm (0.12 in.) or less from any edge.

9.6 *Report*—The report shall include the following:

9.6.1 Description of the insulation tested,

9.6.2 Test method for corrosiveness used, and

9.6.3 The absence or presence of perforations of or by the metal coupons. Notches extending into the coupon 3 mm (0.12 in.) or less from any edge shall be ignored. The absence or presence or perforation by type of metal coupon may also be reported.

9.7 *Precision and Bias*—No statement is made about the precision and bias of this test method since it is a qualitative method and no numerical value is obtained.

## 10. Critical Radiant Flux

10.1 The critical radiant flux of the insulation shall be determined in accordance with Test Method E 970-89.

10.2 *Sample Preparation:*

10.2.1 Condition specimens in accordance with Test Method E 970 section 11.

10.2.2 *Procedures:*

10.2.2.1 *Method A*—Blow the material through a commercial blower using 30.5 m (100 ft) of 5.08-cm (2-in.) diameter hose into a sample receiver while holding the hose horizontally at a height of 4 ft. Hand load the specimen tray, being careful not to compact the insulation.

10.2.2.2 *Method B*—Blow the material through a commercial blower using 30.5 m (100 ft.) of 5.08-cm. (2-in.) diameter hose directly into the specimen tray while holding the hose horizontally at a height of 4 ft.

10.2.3 Gently shake specimen, removing excess and over-blown insulation. The specimen shall then be gently screeded with a metal straight edge in one direction so that the specimen

is level across the top of the tray. Surface irregularities shall not exceed 4.8 mm ( $\frac{3}{16}$  in.). Additional material may be added to fill any voids or valleys around the periphery of the specimen tray. Take care not to compact the insulation. The tray may now be inserted in the radiant panel. As an alternative to screeding, the specimen tray may be gently dropped onto a hard level surface until the specimen is level with the sides of the specimen tray.

## 11. Fungi Resistance

11.1 *Scope*—This test method covers the determination of the amount of resistance to the growth of fungi present in cellulosic loose-fill insulation materials.

11.2 *Significance and Use*—It is necessary to ensure that cellulosic loose-fill insulation materials support no greater growth of fungi than the surrounding materials of the structure being insulated. Normally the structural materials in question will be wood. Excessive growth of fungi on the insulation could result in loss of efficiency of the insulation, damage to the structure, and possible health hazards to the occupants of the insulated structure. The purpose of this test method is to provide an evaluation of the potential for fungi growth present in the insulation material relative to common wood use for framing.

11.3 *Apparatus*—The apparatus required to conduct this test method consists of chambers or cabinets together with auxiliary instrumentation capable of maintaining the specified conditions of temperature and humidity.

11.4 *Sampling*—Unless specified by the purchaser, one specimen shall be selected from each of three different bags or other packages of insulation, as applicable.

11.5 *Procedure:*

11.5.1 Prepare mineral-salts agar in accordance with Table 2.

11.5.1.1 Sterilize the mineral-salts agar by autoclaving at  $121^\circ\text{C}$  ( $250^\circ\text{F}$ ) for 20 min. Adjust the pH of the solution with 0.01 normal solution of NaOH so that after sterilization the pH is from 6.0 to 6.5. Reagent grade chemicals shall be used in all tests. Unless otherwise specified, it is intended that all reagents shall conform to the specifications of the Committee on Analytical Reagents of the American Chemical Society, where such specifications are available.<sup>6</sup>

11.5.1.2 Unless otherwise specified, reference to water shall be understood to mean sterile and either distilled or deionized water or water of equal purity.

11.5.2 *Preparation of Mixed Spore Suspension*—Use the test fungi prescribed in Table 3.

**TABLE 2 Preparation of Mineral Salts Agar**

Chemical	Amount
Sodium nitrate (NaNO <sub>3</sub> )	2.0 g
Magnesium sulfate (MgSO <sub>4</sub> )	0.5 g
Potassium chloride (KCl)	0.5 g
Ferric sulfate (Fe <sub>2</sub> (SO <sub>4</sub> ) <sub>3</sub> ·9H <sub>2</sub> O)	0.01 g
Potassium dihydrogen orthophosphate (KH <sub>2</sub> PO <sub>4</sub> )	0.14 g
Potassium monohydrogen orthophosphate (K <sub>2</sub> HPO <sub>4</sub> )	1.2 g
Agar	15.0 g
Sterile and either distilled or deionized water	1.0 L
Yeast extract	0.02 g

**TABLE 3 Test Fungi for Preparation of Mixed Spore Suspension**

Fungi	ATCC <sup>A</sup>
Aspergillus niger	9642
Aspergillus flavus	9943
Aspergillus versicolor	11730
Penicillium funiculosum	11797
Chaetomium globosum	6205

<sup>A</sup> American Type Culture Collection, 12301 Parklawn Dr., Rockville, MD 20852.

11.5.2.1 Maintain separate cultures of these fungi on an appropriate medium such as potato dextrose agar. However, the culture of chaetomium globosum shall be maintained on strips of filter paper on the surface of mineral salts agar (described in 11.5.1.1). The stock culture may be kept for no more than 4 months at  $6 \pm 4^\circ\text{C}$  ( $43 \pm 7^\circ\text{F}$ ) at which time subcultures shall be made, and new stocks shall be selected from the subcultures. If genetic or physiological changes occur, obtain new cultures as specified previously. Subcultures used for preparing new stock cultures or the spore suspension shall be incubated at  $30^\circ\text{C}$  ( $86^\circ\text{F}$ ) for 9 days or longer. Prepare a spore suspension of each of the five fungi by pouring 10 mL of a sterile solution containing 0.05 g/L of a nontoxic wetting agent such as sodium dioctyl sulfosuccinate or sodium lauryl sulfate onto each culture. Use a sterile platinum or nichrome inoculating wire to gently scrape the surface growth from the culture of the test organism. Pour the spore charge into a sterile 125-mL glass-stoppered Erlenmeyer flask containing 45 mL of sterile and either distilled or deionized water and 50 to 75 solid glass beads, 5 mm (0.20 in.) in diameter. Shake the flask vigorously to liberate the spores from the fruiting bodies and to break the spore clumps. Filter the dispersed fungal spore suspension through a 6-mm (0.24-in.) layer of glass wool contained in a glass funnel, into a sterile flask. This process is intended to remove large mycelial fragments and clumps of agar that could interfere with the spraying process. Centrifuge the filtered spore suspension aseptically, and discard the supernatant liquid. Re-suspend the residue in 50 mL of sterile and either distilled or deionized water and centrifuge. Wash the spores obtained from each of the fungi in this manner three times. Dilute the final washed residue with sterile and either distilled or deionized water so that the resulting spore suspension shall contain  $1\,000\,000 \pm 200\,000$  spore/mL as determined with a counting chamber. Repeat the operation for each organism used in the test and blend equal volumes of the resultant spore suspensions to obtain the final mixed spore suspension. The spore suspension may be prepared fresh each day, or may be held at  $6 \pm 4^\circ\text{C}$  ( $43 \pm 7^\circ\text{F}$ ) for no more than 7 days.

11.5.3 *Viability of Inoculum Control*—With each daily group of tests, place one each of three pieces of sterilized filter paper, 1-in.<sup>2</sup>, on hardened mineral-salts agar in separate covered petri dishes. Inoculate these with the spore suspension by spraying approximately 0.5 mL of the suspension from a sterilized atomizer (an atomizer capable of providing  $15\,000 \pm 3000$  spores per square centimetre). Incubate these in the test chamber along with samples at  $30^\circ\text{C}$  ( $86^\circ\text{F}$ ) at a relative humidity of no less than 95 % and examine these controls after 7 days of such incubation. There should be copious growth on all three of the filter paper control specimens. Absence of such

growth requires repetitions of the test.

11.5.4 *Comparative Items*—A section of untreated southern pine approximately 50.8 by 50.8 by 9.5-mm (2 by 2 by  $\frac{3}{8}$ -in.) thick. The upper surface of the pine shall be commercially finished and shall be employed as a comparative item to determine the relative extent of the growth on samples being tested.

11.5.5 *Inoculation of Test and Comparative Item*—Precondition the test area at  $30^\circ\text{C}$  ( $86^\circ\text{F}$ ) and at least 95 % relative humidity for at least 4 h. Place each piece of wood in a sterile petri dish and moisten with 3 mL of sterile and either distilled or deionized water. Moisten a 10-g (0.35 oz) sample of the cellulosic loose-fill insulation with sterile and either distilled or deionized water in accordance with Eq 4 or Eq 5:

$$\frac{29}{d} \times 75 = \text{mL of } H_2O \quad (3)$$

where  $d$  = design density, lb/ft<sup>3</sup>.

Aseptically transfer approximately one third of the insulation mix to each of three sterile petri dishes and gently tamp down to a relatively smooth surface to facilitate subsequent microscopic examination. Inoculation of test and comparative item with the next spore suspension by spraying approximately 0.5 mL onto the contents of each petri dish. The spray shall be in the form of a fine mist from a previously sterilized atomizer or nebulizer. The petri dish shall be covered and incubation shall be started immediately following the inoculation.

11.5.6 *Incubation*—Maintain test conditions at  $30^\circ\text{C}$  ( $86^\circ\text{F}$ ) and at minimum relative humidity of 95 % for 28 days. The test chamber shall be kept closed during the incubation period, except during inspection.

11.5.7 *Inspection*—At the end of the incubation period, the test and comparative item shall be removed from the test chamber and examined at  $40\times$  magnification.

11.6 *Report*—Report the growth observed on each of the three samples as being less than, equal to, or greater than the growth observed on the comparative item.

11.7 *Precision and Bias*—No statement is made about the precision and bias of this test method since it is a qualitative method and no numerical value is obtained.

## 12. Moisture Vapor Sorption

12.1 *Scope*—This test method describes a procedure for determining the percent moisture absorbed from the atmosphere by cellulosic fiber loose-fill insulation product under laboratory conditions.

12.2 *Significance and Use*:

12.2.1 Excessive moisture in attic insulation could lead to deterioration of structural components, as well as possible odor and vermin infestation.

12.2.2 The inherent property of cellulosic fiber to absorb finite amounts of water from the atmosphere, and the possible use of hygroscopic chemicals in fire retardants are factors necessitating testing of production lots of insulation for moisture absorption capability.

12.3 *Apparatus*:

12.3.1 *Specimen Container*, constructed of a noncorrosive- and nonwater-absorbing material  $230 \pm 3$  by  $200 \pm 3$  mm ( $9 \pm 0.1$  by  $9 \pm 0.1$  by  $8 \pm 0.1$  in.). Change is increasing the

depth of the container by 3 in. from 130 to 200 mm. This will give us better representative thickness of R-value for the determination of this test.

12.3.2 *Humidity Chamber*, capable of maintaining the following two sets of conditions:

12.3.2.1  $49 \pm 2.3^{\circ}\text{C}$  ( $120 \pm 4.1^{\circ}\text{F}$ ) and  $50 \pm 5\%$  relative humidity, and

12.3.2.2  $49 \pm 2.3^{\circ}\text{C}$  ( $120 \pm 4.1^{\circ}\text{F}$ ) and  $90 \pm 5\%$  relative humidity.

12.3.3 *Balance*, accurate to 0.1 g (0.0035 oz).

12.4 *Sampling*—The test sample shall be randomly selected from one production lot of insulation.

12.5 *Procedure*:

12.5.1 Determination of moisture sorption shall be at the design density determined in Section 8.

12.5.2 The insulation specimen shall be blown, combed, or otherwise mixed to remove lumps.

12.5.3 Calculate the amount of insulation material required as shown in Eq 4:

$$W = V \times d \quad (4)$$

where:

$W$  = mass of insulation, kg (oz),

$V$  = volume of container,  $\text{m}^3$  ( $\text{ft}^3$ ), and

$d$  = design density,  $\text{kg}/\text{m}^3$  ( $\text{lb}/\text{ft}^3$ ).

12.5.4 Fill the container (see 12.3.1) with the calculated amount of test material.

12.5.5 Condition this test material at  $49 \pm 2.3^{\circ}\text{C}$  ( $120 \pm 4.1^{\circ}\text{F}$ ) and  $50 \pm 5\%$  relative humidity to a constant weight and record the mass. Constant mass has been achieved when successive weighings vary no more than 1 % in 24 h.

12.5.6 Increase the relative humidity to  $90 \pm 5\%$  and recondition for 24 h. Weigh and record within 15 min of removal from this conditioning.

12.6 *Calculations*—Calculate the moisture absorbed as shown in Eq 5:

$$M = \frac{W_2 - W_1}{W_1 - W_3} \times 100 \quad (5)$$

where:

$M$  = moisture absorbed, %,

$W_1$  = weight of container and specimen after conditioning at 50 % relative humidity, g (oz),

$W_2$  = weight of container and specimen after conditioning at 90 % relative humidity, g (oz), and

$W_3$  = weight of the empty container, g (oz).

12.7 *Report*—The report shall contain the following:

12.7.1 Percentage by weight of moisture absorbed,

12.7.2 Sample identification and date of manufacture, if known,

12.7.3 Density at which sample was tested, and

12.7.4 Test conditions, such as temperature, relative humidity, and exposure time.

12.8 *Precision and Bias*—The precision of this test method is not known because inter-laboratory data are not available. Inter-laboratory data are being obtained and a precision statement is being added with the next revision.

### 13. Odor Emissions

13.1 *Scope*—This test method covers the determination of the existence, nature, and degree of odors present in thermal insulation materials.

13.2 *Significance and Use*—Thermal insulating materials that produce objectionable odors could cause discomfort to persons occupying a structure insulated with such materials. Therefore, an examination to determine the odor potential of a particular insulation is desirable.

13.3 *Apparatus*—Containers shall be either all stainless steel or glass with tight-fitting lids. Containers must produce no discernible odor of their own. Capacity of containers shall be a minimum of 50 g of the material to be tested.

13.4 *Sampling*—Unless otherwise specified by the purchaser, one sample of the material to be tested shall be selected at random. Each sample shall contain a minimum of 50 g (1.8 oz) of insulation.

13.5 Condition samples in accordance with 8.4.

13.6 *Procedure*:

13.6.1 Insert the sample into a test container and firmly replace the lid. Subject each closed container to a temperature of  $65^{\circ}\text{C}$  ( $149^{\circ}\text{F}$ ) for a period of 30 min.

13.6.2 A panel of five persons having normal odor perception shall open and examine for odor in the test containers.

13.6.3 The panel members shall answer the following questions regarding the sample examined:

13.6.3.1 Was a perceptible odor present?

13.6.3.2 If so, was the odor objectionable, pleasant, or neutral?

13.6.3.3 Was the odor weak, strong, or very strong?

13.7 *Report*—A test report shall be prepared indicating whether the tested material passed or failed. The report shall also include the compiled panel opinions as follows:

13.7.1 Was a perceptible odor present? Yes \_\_\_ No \_\_\_. If so: \_\_\_\_\_.

13.7.2 Odor was objectionable \_\_\_ pleasant \_\_\_ neutral \_\_\_\_\_.

13.7.3 Odor was weak \_\_\_ strong \_\_\_ very strong \_\_\_\_\_.

13.7.4 *Precision and Bias*—No statement is made about either the precision or the bias of this odor emission method since the results merely determine whether the material emits an objectionable odor or not. See Note 6.

NOTE 6—Panel members shall be persons who have demonstrated an ability to detect odors accurately and consistently. A recommended method for panel selection is given in the paper The Selection of Judges of Odor Discrimination Panels.<sup>7</sup>

### 14. Smoldering Combustion

14.1 *Scope*—This test method determines the resistance of the insulation to smolder under specific laboratory conditions.

14.2 *Significance and Use*—Insulation materials that readily smolder could have an adverse effect on the surrounding structure in the event of exposure to fire or heat sources.

14.3 *Apparatus*:

14.3.1 *Specimen Holder*—The specimen holder shall be an open-top  $200 \pm 2\text{-mm}$  ( $7.9 \pm 0.08\text{-in.}$ ) square box,  $100 \pm 2$

<sup>7</sup> *Symposium on the Correlation of Subjective-Objective Methods in the Study of Odors and Taste, ASTM STP 440, ASTM, 1968, pp. 49-70.*





mm ( $3.9 \pm 0.08$  in.) in height, fabricated from  $0.61 \pm 0.08$ -mm ( $0.024 \pm 0.003$ -in.) thick (22–26 U.S. standard gage) stainless steel sheet with the vertical edges of the box overlapped, not to exceed 7 mm (0.273 in.) in seam width, and joined to be watertight. The specimen holder during test use shall rest upon a pad of unfaced glass fiberboard having dimensions equal to and not less than those of the bottom of the specimen holder. The glass fiberboard shall be approximately 25-mm (0.98-in.) thick, with a density of  $40 \pm 4$  kg/m<sup>3</sup>.

14.3.2 *Ignition Source*—The ignition source shall be a cigarette without filter tip made from natural tobacco,  $85 \pm 2$ -mm ( $3.342 \pm 0.08$ -in.) long with a tobacco packing density of  $0.27 \pm 0.020$  g/cm<sup>3</sup> and a total mass of  $1.1 \pm 0.2$  g (0.04  $\pm$  0.007 oz).

14.3.3 *Balance*, 1-kg (2.2-lb) capacity, accurate at least to 0.1 g (0.004 oz).

14.3.4 *Hot Wire Anemometer*, having a range of measurement to include 0.5 m/s (99 ft/min).

14.3.5 *Solid Glass Rod*, 8 mm (0.32 in.), having one smooth tapered end.

14.4 *Sampling*—Three specimens per sample shall be tested.

14.5 *Conditioning*—Samples and cigarette shall be conditioned in an open container in accordance with 8.4.

14.6 *Procedure*:

14.6.1 Draft-protect and equip the test area with a suitable system for exhausting smoke or noxious gases, or both, produced by testing. Air velocities measured by a hot wire anemometer in the vicinity of the surface of the sample shall not exceed 0.5 m/s. Maintain the test area at  $21 \pm 2^\circ\text{C}$  (69.8  $\pm$  3.6°F) and  $50 \pm 5$  % relative humidity.

14.6.2 Calculate the mass of material necessary to fill the holder (volume of 4000 cm<sup>3</sup> (or 0.14 ft<sup>3</sup>) at the design density as determined in Section 8. Blow, comb, or otherwise mix the material to remove lumps. Load the material uniformly into each specimen holder, level and flush to the top of the holder. Measure the mass of each specimen to the nearest 0.2 g (0.007 oz) or less by weighing the holder before and after filling. If the mass of the specimen is less than calculated, place a removable extension top on top of the holder; place the necessary amount of insulation inside the extension and drop the loaded holder from a height of no greater than 76 mm (3 in.) onto a hard flat surface. Repeat this process until the specimen settles uniformly to the top of the holder. Then remove the extension top.

14.6.3 With the specimen in the holder and placed on the insulation pad, vertically insert a glass rod into the center of the material ( $\pm 10$  mm) being tested to a depth equivalent to the length of the cigarette, and withdrawn to form a cavity for the ignition source, so that the cigarette fits snugly and maintains uniform contact with the specimen. Insert a well-lighted cigarette, burned no more than 8 mm (0.31 in.) into the formed cavity, with the lit end upward and flush with the specimen surface. Allow burning of the cigarette to proceed undisturbed in the test area for at least 2 h or until the smoldering is no longer progressing, whichever period is longer.

14.6.4 Test all insulation samples for smolder combustion in triplicate.

14.6.5 If one specimen fails, perform another set. If any one

of the second set of specimens fails, the sample fails. If any one of the specimens fails, the sample fails.

14.7 *Calculations*—After completion of burning and after the holder has cooled to 25°C (77°F) or less, weigh the specimen holder with its material residue at least to the nearest 0.2 g (0.07 oz), and calculate the percent mass loss of the original specimen. Ignore the mass of the cigarette residue in this calculation. Calculate the mass loss as shown in Eq 6:

$$W = \frac{W_1 - W_2}{W_1} \times 100 \quad (6)$$

where:

$W$  = mass loss, %,

$W_1$  = mass of insulation before test, g (oz), and

$W_2$  = mass of insulation at completion of test, g (oz).

14.8 *Report*—The report shall include the following:

14.8.1 Percent mass loss and evidence of flaming, if any,

14.8.2 Sample identification and date of manufacture,

14.8.3 Statement of sample conditioning and preparation,

14.8.4 Statement of test density,

14.8.5 Number of tests performed, and

14.8.6 Results of test: Pass/Fail.

14.9 *Precision and Bias*:

14.9.1 *Precision*—Interlaboratory tests were performed to evaluate the repeatability and reproducibility of this test for cellulose insulation. These tests were based on Federal Specification HH-I-515D. Seven commercially manufactured cellulose insulations, marketed for residential use, were evaluated by each procedure. Ten laboratories participated in conducting the tests. Data from the soldering combustion test was evaluated on a pass/fail basis with agreement by nine of ten laboratories for six of the seven materials tested. Seven of the ten laboratories also agreed on the seventh material.

14.9.2 *Bias*—No information can be presented on the bias of this test method because no material having an accepted reference value is available.

## 15. Thermal Resistance

15.1 Using samples prepared in accordance with Section 8, design density, the thermal conductivity or thermal conductance shall be determined in accordance with Test Method C 518, C 177, C 1114, or C 236.

15.2 The mean temperature for determination of thermal conductivity shall be 23.9°C (75°F), using the procedure presented in Practice C 687.

15.3 Values for thermal resistance at other mean temperatures may be determined using the same procedure as steps 15.1 and 15.2 but at alternate mean temperatures.

## 16. Inspection

16.1 Inspection of the insulation shall be made as agreed upon by the purchaser and the manufacturer as part of the purchase contract.

## 17. Packaging and Package Marking

17.1 *Packaging*—Unless otherwise specified, the insulation shall be packaged in the manufacturer's standard commercial containers.

17.2 *Marking*—Each bag of insulation shall be marked to include the following:



**TABLE 4 Example of Suggested Form for Insulation Coverage Chart**

R Value at 75°F Mean Temperature (to obtain an insulation resistance (R))	Maximum Net Coverage		Thickness, in., min (that insulation should be not less than)	Weight, lb/ft <sup>2</sup> , min (that insulation should be not less than)
	Bags/1000 ft <sup>2</sup>	Maximum coverage per bags, ft <sup>2</sup>		
<i>Attic:</i>				
R-50	—	—	—	—
R-44	—	—	—	—
R-40	—	—	—	—
R-38	—	—	—	—
R-32	—	—	—	—
R-30	—	—	—	—
R-24	—	—	—	—
R-22	—	—	—	—
R-19	—	—	—	—
R-13	—	—	—	—
R-11	—	—	—	—
<i>Sidewalls:</i>				
R—	—	—	—	—

17.2.1 Name of manufacturer,

17.2.2 Manufacturing date and location,

17.2.3 Net weight of insulation per bag,

17.2.4 Whether the manufacturer recommends that the insulation be installed at these minimum thicknesses, minimum weights, and maximum coverages, to provide the levels of insulation thermal resistance (*R*) shown,

17.2.5 Filled-in coverage chart shall be based on the design density determined in Section 8, which shall contain the information prescribed in Table 4,

17.2.6 Optional information for products intended for side-wall application,

17.2.6.1 *Certification*—“This insulation has been installed

in conformance with the above recommendations, to provide a value of *R*— \_\_\_ using \_\_\_ bags of this insulation to cover \_\_\_ square feet of area,” including:

17.2.6.2 Place for builder’s signature, company name, and date, and

17.2.6.3 Place for applicator’s signature, company, name, and date, and

17.2.7 Where material is intended for blowing or pouring application, the bag shall have a separate coverage for each type of application.

### 18. Keywords

18.1 cellulosic fiber; loose-fill; thermal insulation

## APPENDIXES

### (Nonmandatory Information)

#### X1. ELECTRIC RADIANT PANEL

X1.1 For purposes of establishing in-house quality control conformance to critical radiant flux criteria, manufacturers may

establish correlation between their electric radiant panel<sup>8</sup> and an accredited radiant panel.

<sup>8</sup> The Veri Flux 100 electric radiant panel manufactured by Clayville Labs, P.O. Box 713, Burley, ID 83313, (208) 678-9791, or equivalent has been found suitable for this purpose.

## **X2. CPSC SAMPLING PROCEDURES FOR TEST METHOD E 970 CRITICAL RADIANT FLUX**

### **X2.1 Sample Preparation:**

X2.1.1 Condition specimens in accordance with Test Method E 970, Section 11.

X2.1.2 Insulation shall be installed into the specimen tray using the blower-cyclone apparatus. For this purpose, the fill chamber (See Figs. 1 and 2), shall be equipped with the openings in the front and back so that a radiant panel specimen tray can be slid through the fill chamber during blowing.

X2.1.3 Adjust the blower control(s) so that the supply and overflow blowers will operate at no-load voltage of 40 V rms.

X2.1.4 Simultaneously turn on the blowers and proceed to fill the fill chamber by picking up material from the insulation-holding container, using the supply source hose. Do not pre-blow the insulation. Large clumps of insulation shall be broken by hand before feeding them into the hose. Continue

filling the chamber until large amounts of insulation are being drawn into the overflow hose.

X2.1.5 Slowly slide the specimen tray through the fill chamber so that the low flux end of the tray is parallel with the back of the fill chamber, filling the by sliding the tray forward to allow excess of insulation to build up in the tray.

X2.1.6 Shut off the blowers and remove the specimen tray. The specimen shall be gently raked with a wide toothed comb to eliminate any voids. The specimen shall then be gently screeded with a metal or wood straight edge in one direction so that the specimen is level across the top of the tray. Surface irregularities shall not exceed 4.8 mm ( $\frac{3}{16}$  in.). Additional material may be added to fill any voids or valleys around the periphery of the specimen tray. Take care not to compact the insulation. The tray may now be inserted in the radiant panel.

*ASTM International takes no position respecting the validity of any patent rights asserted in connection with any item mentioned in this standard. Users of this standard are expressly advised that determination of the validity of any such patent rights, and the risk of infringement of such rights, are entirely their own responsibility.*

*This standard is subject to revision at any time by the responsible technical committee and must be reviewed every five years and if not revised, either reapproved or withdrawn. Your comments are invited either for revision of this standard or for additional standards and should be addressed to ASTM International Headquarters. Your comments will receive careful consideration at a meeting of the responsible technical committee, which you may attend. If you feel that your comments have not received a fair hearing you should make your views known to the ASTM Committee on Standards, at the address shown below.*

*This standard is copyrighted by ASTM International, 100 Barr Harbor Drive, PO Box C700, West Conshohocken, PA 19428-2959, United States. Individual reprints (single or multiple copies) of this standard may be obtained by contacting ASTM at the above address or at 610-832-9585 (phone), 610-832-9555 (fax), or service@astm.org (e-mail); or through the ASTM website (www.astm.org).*