



Standard Guide for The Installation of Operable Partitions¹

This standard is issued under the fixed designation E 557; the number immediately following the designation indicates the year of original adoption or, in the case of revision, the year of last revision. A number in parentheses indicates the year of last reapproval. A superscript epsilon (ϵ) indicates an editorial change since the last revision or reapproval.

1. Scope

1.1 This guide describes options of instructions recommended to be considered in preparation for, and application and installation of, operable partitions and, to some extent, in the design of the building in which they are installed. Operable partitions are those that are quickly movable.

1.2 Excluded from this guide are those partitions that are classified by the building products industry as *demountable*. Demountable partitions are those that are designed and installed with the intent of later being taken down and re-erected by a crew over a period of time, with the components being reusable.

1.3 *This standard does not purport to address all of the safety problems, if any, associated with its use. It is the responsibility of the user of this standard to establish appropriate safety and health practices and determine the applicability of regulatory limitations prior to use.*

2. Referenced Documents

2.1 ASTM Standards:

E 90 Test Method for Laboratory Measurement of Airborne Sound Transmission Loss of Building Partitions and Elements²

E 336 Test Method for Measurement of Airborne Sound Insulation in Buildings²

E 413 Classification for Rating Sound Insulation²

E 497 Practice for Installing Sound-Isolating Lightweight Partitions²

E 1155 Test Method for Determining Floor Flatness and Levelness Using the *F*-Number System³

E 1155M Test Method for Determining Floor Flatness and Levelness Using the *F*-Number System (Metric)³

3. Significance and Use

3.1 Rooms formed by operable partitions must often be isolated acoustically. Sound-isolating properties of operable

partitions are specified by architects in terms of sound transmission class (STC) and so advertised by the manufacturer on the basis of laboratory tests in accordance with Test Method E 90 and Classification E 413.

3.2 Because normal building design and construction practices are not the same as those used in acoustical laboratories, actual field performance of operable partitions will probably be less than that of test specimens. Sound transmission between areas to be isolated will occur through all of the connecting building components in addition to the operable partition, that is, floor and ceiling slabs, ceiling plenums, common walls, etc. All possible paths between the areas being isolated should have a sound insulation performance at least equal to the operable partition. Unless good acoustical practice is followed in both building design and installation, there may be a significant discrepancy between the sound isolation expected and that achieved.

3.3 Because of the complex nature of the sound flanking paths adjacent to operable partitions, it is highly recommended that all related construction details be reviewed by a person qualified in acoustical construction.

3.4 This guide does not specify requirements. However, persons desiring to write installation and construction specifications may find the contents useful in developing requirements for the site preparation, and installation practices necessary to minimize leakage and flanking sound around the operable partition.

4. Properties of Operable Partitions

4.1 There are several types of operable partitions: hinged panel groups, individual panel and continuously hinged partition systems. Some are supported by overhead track with or without a floor guide or track. Some are floor supported with an overhead track to guide them. They may be manual or power-operated. One type consists of movable panels secured in place by vertical expansion to seal against the floor and ceiling. Seals or gaskets are of many kinds; some consist of resilient material that maintains continuous flexible contact with floor or ceiling, and some include a mechanical, hydraulic or pneumatic mechanism that maintains clearance when in motion and a positive seal when finally closed.

4.2 Sound Leaks:

¹ This guide is under the jurisdiction of ASTM Committee E33 on Environmental Acoustics and is the direct responsibility of Subcommittee E33.04 on Application of Acoustical Materials and Systems.

Current edition approved September 10, 2000. Published July 2001. Originally published as E 557-75. Last previous edition E 557-93.

² *Annual Book of ASTM Standards*, Vol 04.06.

³ *Annual Book of ASTM Standards*, Vol 04.07.

4.2.1 The seals at the top of the partitions should make continuous contact with smooth surfaces on both sides of the operable partitions. The sound path through an insufficient seal, up and over the track, and out on the other side through the insufficient seal constitutes a serious sound leak.

4.2.2 When a partition consists of several panels, leaks may occur at the vertical joints when the seals at the joint are not tight.

4.2.3 Pass-through doors in partitions will generally reduce the overall sound isolation of the wall. For this reason, pass-through doors should be equipped with full perimeter gasketing, including seals at head.

4.2.4 Track assemblies installed outside the partition storage pocket area to form cross-through paths (90° to each other) primarily for the transport of partitions from one location to the other should be avoided unless a satisfactory method is provided to reduce the flanking path created through the track section from one side of the partition to the other.

4.3 *Sound Flanking Paths*—Although the operable partition may be an adequate barrier itself, sound may pass from one side to the other by going over, around, or under the partition. The passage of sound by paths other than directly through the partition itself is called flanking transmission.

5. Recommendations

5.1 Area Above Track:

5.1.1 If there is a plenum above the partition, sound may pass up through the ceiling on one side and down through the ceiling on the other. A barrier should be erected directly above the operable partitions. This barrier, in conjunction with the ceiling, should have a sound transmission loss equal to or greater than that of the partition. The barrier is best designed as part of the building and not added as an afterthought (see Fig. 1). Often a seemingly solid ceiling has hollows behind it, such as spaces between the joists, or spaces in corrugated decks, that provide a flanking path around an operable partition below. The hollow spaces must be blocked directly above the operable partition. The sound transmission loss provided by the blocking barrier should be equal to or greater than that provided by the operable partition.

5.1.2 When a plenum is part of the air conditioning system, a sound-attenuating duct or silencer is recommended to control possible flanking and should be installed through the barrier wall straddling the operable partition below. The composite sound transmission loss of the duct or silencer, and the ceiling, should be equal to or greater than the sound transmission loss of the partition (see Fig. 2).

NOTE 1—Lagging of the silencer or ductwork, or constructing these of heavier gage sheet metal, may be required on both sides of the barrier wall to achieve the necessary composite sound transmission loss requirements.

5.1.3 Generally, track systems for operable partitions are installed during the early phases of building interior construction. The panels are often among the last items installed in the building. The barrier above the track may be built between these two events. To level the track after the weight of the panels is applied, manufacturers and installers of operable partitions request access to the area above the track. This can conflict with the need to build a barrier in the same area. It is

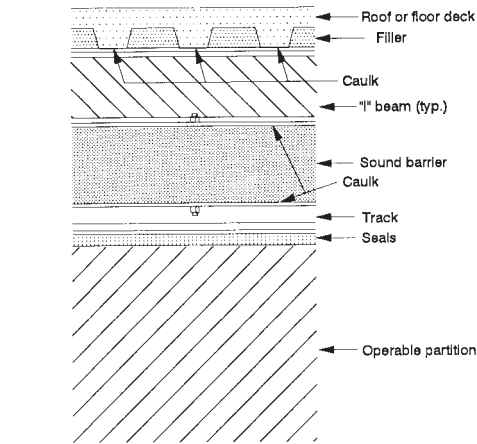
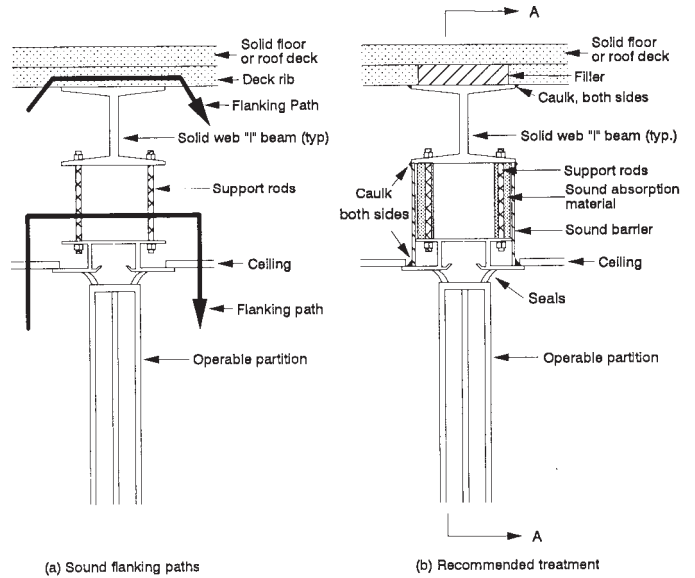

FIG. 1 Recommended Ceiling Barrier Installation

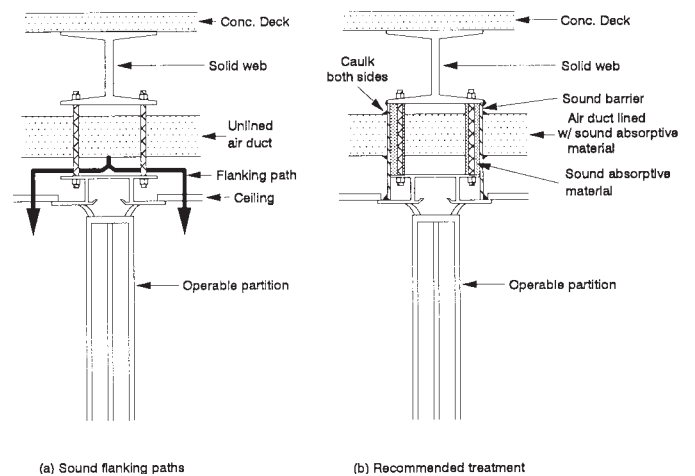

FIG. 2 Recommended Sound Attenuating Duct Installation

important to work out a design that provides an adequate acoustical barrier and allows access for adjustment of the track. If built-in access doors or removable gypsum board panels are

used for this purpose, they should be sealed at the periphery with solid or closed cell gaskets.

5.1.4 If doors or removable panels used to cover openings in a monolithic ceiling, to gain access for servicing partition drive train components, the openings should be sufficiently large to permit all service operations without modification or damage to the ceiling. The covers should be sealed at the periphery with solid or closed cell gaskets. Fig. 3 shows the recommended locations of access panels. The doors or removable access panels should have a sound transmission loss equal to or greater than the ceiling transmission loss.

5.2 Floor Below Partition:

5.2.1 Some types of floors are intentionally designed with hollow spaces below (for example, some gymnasium wood floors or computer room access floors). Where there is a hollow space under the operable partition, sound may pass down through the floor on one side and up through the floor on the other. A barrier should be erected directly below the operable partition. The barrier, in conjunction with the floor, should have a sound transmission loss equal to or greater than that of the partition (see Fig. 4, (a) and (b)).

5.2.2 If the floor is carpeted, it will be difficult to obtain a good seal at the bottom of the operable partition. It is preferable to replace the carpet with a strip of smooth material, such as metal, wood, or vinyl, where the bottom seals make contact with the floor (see Fig. 5 (a) and (b)).

5.2.3 The seals at the bottom of the partition should make airtight contact with the floor. The floor immediately under the partition should not vary from a smooth level surface by more than $\pm 1/8$ in. (± 3.2 mm) in 12 ft (3.7 m) non-accumulative. A steel member, such as a standard terrazzo strip, can be placed in a concrete floor to ensure this accuracy (see Fig. 5 (b)). Test Methods E 1155 and E 1155M are test methods for measuring floor flatness and levelness.

5.2.4 When floors under operable partitions are on upper stories, they are subject to live load deflections. If the deflections exceed the ability of the bottom seals of the operable

partition to extend, all seal contact will be lost, opening a large sound leak. Either the floor should be designed to limit the deflections to less than the extension offered by the operable partition, or an operable partition whose bottom seals offer sufficient extension to maintain contact with the floor under these conditions should be specified.

5.2.5 If the operable partition extends directly to a floor truss or to the underside of a floor structure, the use of a slip joint may be considered to accommodate deflection of the floor. All slip joints shall be specially designed or tested, or both, to ensure that no sound leakage is introduced.

5.3 End Conditions:

5.3.1 Operable partitions use various techniques to seal against permanent walls and partitions. These may include bulb seals, telescoping closures, fixed jambs mounted to the permanent wall or partition, or jambs recessed into the permanent surface. In any case, provision should be made to permit an airtight closure against the permanent wall, including gaps in baseboards, chair rails, crown moldings, and other surface-mounted trim on the wall surface. Additionally, provision should be made to ensure flanking sound is not conducted through the structure of the permanent walls and partitions.

5.3.2 Operable partitions generally close against one of the following permanent walls or partitions, which should apply the accompanying design and construction considerations.

5.3.2.1 Fixed partitions in the same plane as the operable partition should have a sound transmission loss equal to or greater than that of the operable partition.

5.3.2.2 Gypsum-board-on-stud fixed partitions perpendicular to the operable partition should have solid backing directly behind the fixed jamb or bulb seal contact point to resist bowing when the operable partition applies pressure. The blocking should be designed similar or equivalent to that shown in Fig. 6 (a) and (b). Often it is best to fill the fixed operable partition with mineral or glass wool to increase its sound transmission loss. See Practice E 497.

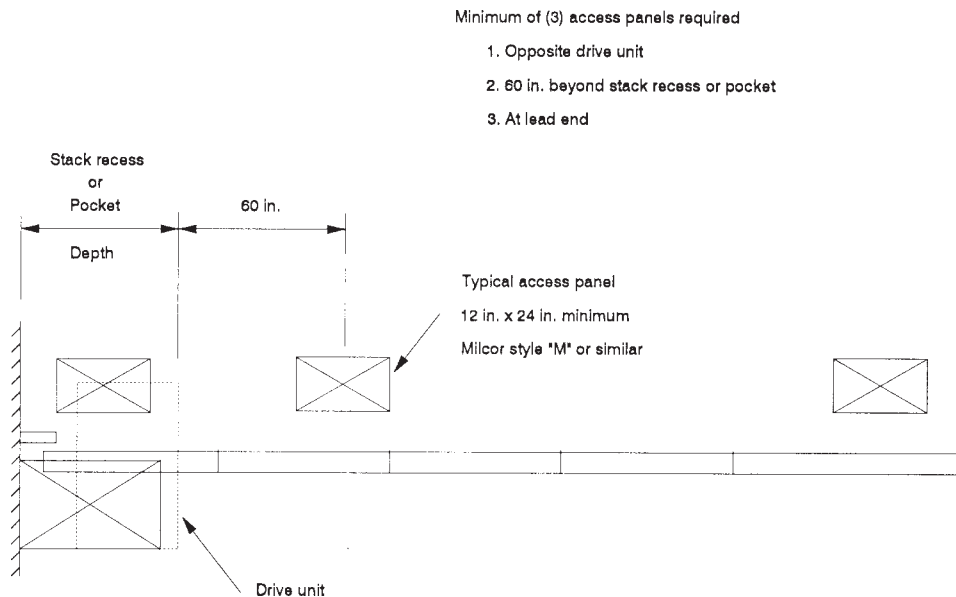

FIG. 3 Ceiling Access Panels for Partitions With or Without a Pocket

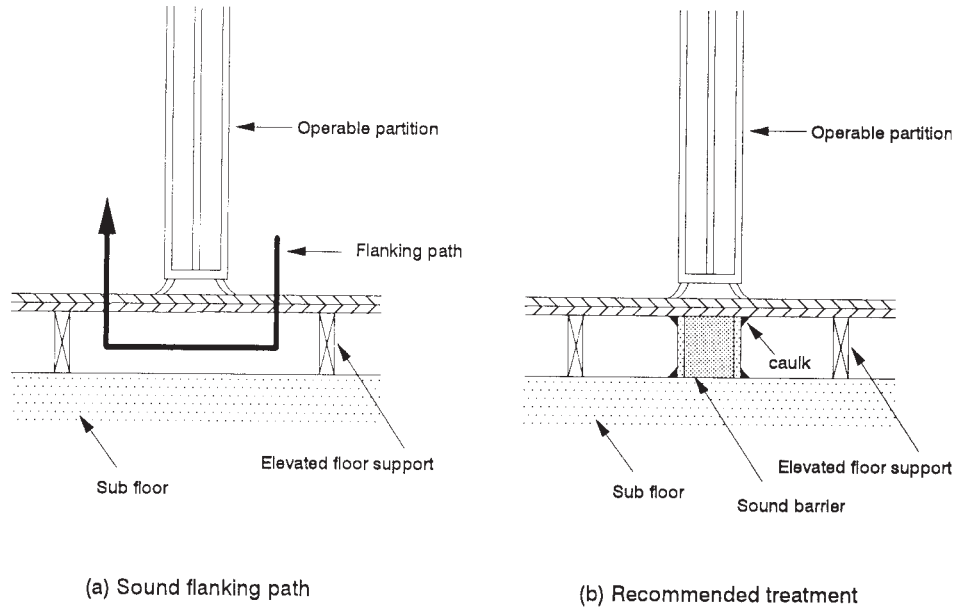

FIG. 4 Recommended Floor Barrier Installation

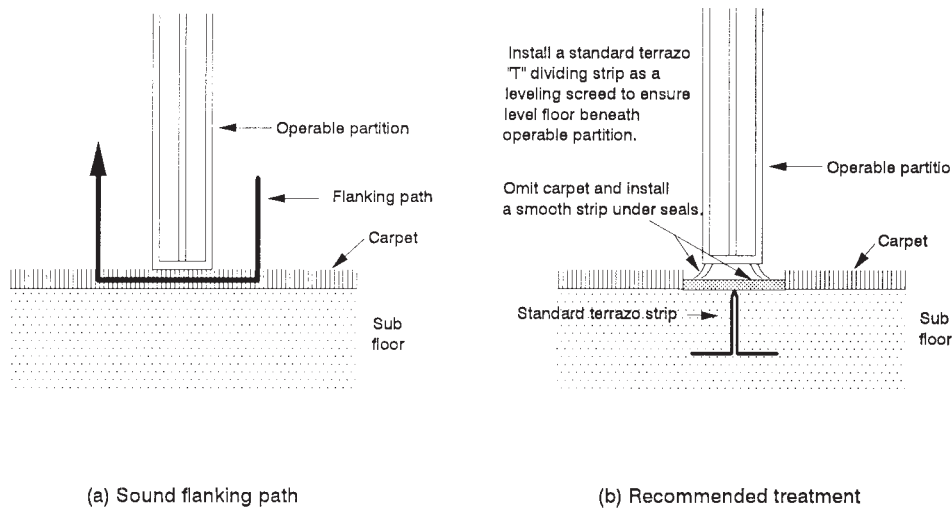

FIG. 5 Recommended Floor Leveling Installation

5.3.2.3 Concrete block or brick walls without facing usually have concave grout lines which can be severe flanking paths. Either a fixed jamb or a smooth closure surface should be mounted to the wall and caulked or sealed in place.

5.3.2.4 Gypsum board furred from masonry walls or surrounding columns should be blocked and filled at the jamb. Fig. 7 (a) and (b) show typical details.

5.3.3 It is necessary to obtain good contact between the operable partition and the fixed jamb (if used) or the bulb seal and the permanent wall. If a fixed jamb is used, it should be plumb and the partition adjusted to exert adequate pressure. The surface to receive the jamb or bulb seals should be plumb to within $\pm 1/8$ in. (± 3.2 mm) for every 10 ft (3.0 m) of height. The fixed portion of the jamb should be caulked or sealed to the wall to prevent leaks between it and the building construction (see Fig. 6 (b)).

5.4 Structural Support for Operable Partitions—The weight of the operable partition, in addition to all dead loads,

should be taken into consideration when designing the supporting member. Deflection under maximum anticipated load should be no more than $1/8$ in. (3.2 mm) per 12 ft (3.7 m) of opening width. If greater deflection is anticipated, either a structural member independent of the roof structure should be installed to support the operable partition, or an operable partition with bottom seals designed to accommodate the larger deflection should be specified.

5.5 Focusing of Sound—Partitions with curved surfaces that can bring sound to a focus should be avoided. They can cause acoustical problems within the enclosed space entirely apart from any noise that may intrude from the outside.

6. Verification of Field Performance

6.1 At the option of the owner, if the field acoustical performance is to be verified, a field sound test shall be conducted in accordance with Test Method E 336, and the

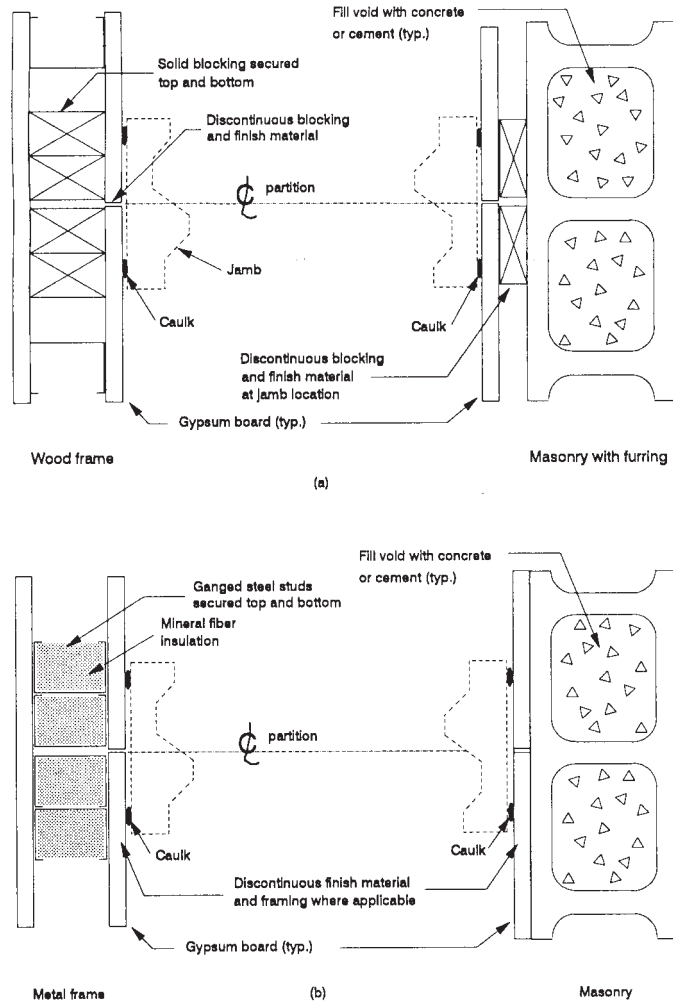
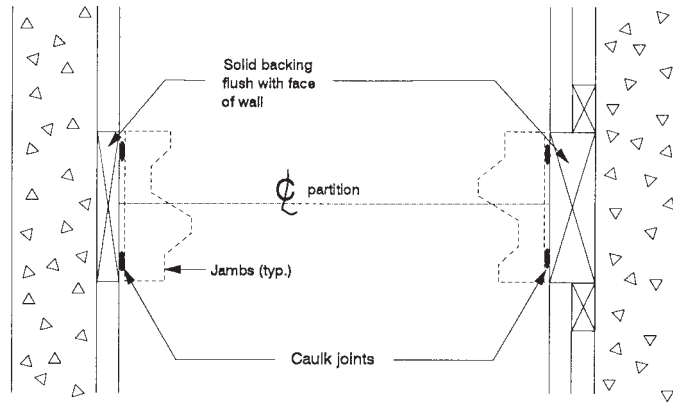

FIG. 6 Typical Wall/Jamb Details

Noise Isolation Class (NIC) should be calculated in accordance with Classification E 413.

7. Keywords

7.1 acoustic; installation; movable; operable; partitions; sound



(a)

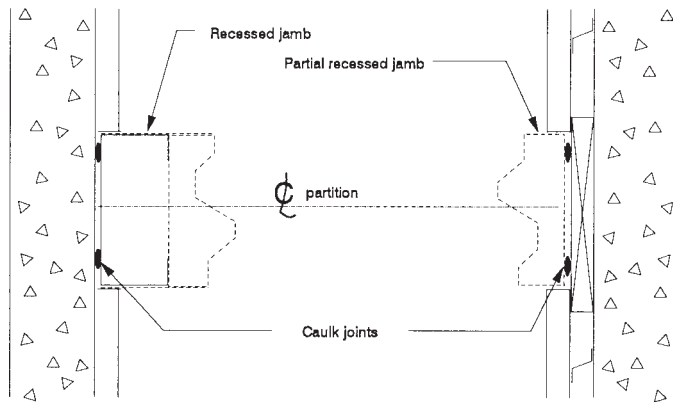

(b)

FIG. 7 Recommended Treatment for Filled Masonry or Concrete Walls With Gypsum or Facing Board

ASTM International takes no position respecting the validity of any patent rights asserted in connection with any item mentioned in this standard. Users of this standard are expressly advised that determination of the validity of any such patent rights, and the risk of infringement of such rights, are entirely their own responsibility.

This standard is subject to revision at any time by the responsible technical committee and must be reviewed every five years and if not revised, either reapproved or withdrawn. Your comments are invited either for revision of this standard or for additional standards and should be addressed to ASTM International Headquarters. Your comments will receive careful consideration at a meeting of the responsible technical committee, which you may attend. If you feel that your comments have not received a fair hearing you should make your views known to the ASTM Committee on Standards, at the address shown below.

This standard is copyrighted by ASTM International, 100 Barr Harbor Drive, PO Box C700, West Conshohocken, PA 19428-2959, United States. Individual reprints (single or multiple copies) of this standard may be obtained by contacting ASTM at the above address or at 610-832-9585 (phone), 610-832-9555 (fax), or service@astm.org (e-mail); or through the ASTM website (www.astm.org).