



# Standard Test Method for Laboratory Measurement of Airborne Sound Transmission Loss of Building Partitions and Elements<sup>1</sup>

This standard is issued under the fixed designation E 90; the number immediately following the designation indicates the year of original adoption or, in the case of revision, the year of last revision. A number in parentheses indicates the year of last reapproval. A superscript epsilon (ε) indicates an editorial change since the last revision or reapproval.

## INTRODUCTION

This test method is part of a set for evaluating the sound-insulating properties of building elements. It is designed to measure the transmission of sound through a partition or partition element in a laboratory. Others in the set cover the measurement of sound isolation in buildings (Test Method E 336), the laboratory measurement of impact sound transmission through floors (Test Method E 492), the measurement of impact sound transmission in buildings (Test Method E 1007), the measurement of sound transmission through building facades and facade elements (Guide E 966), the measurement of sound transmission through a common plenum between two rooms (Test Method E 1414), a quick method for the determination of airborne sound isolation in multiunit buildings (Practice E 597), and the measurement of sound transmission through door panels and systems (Test Method E 1408).

## 1. Scope

1.1 This test method covers the laboratory measurement of airborne sound transmission loss of building partitions such as walls of all kinds, operable partitions, floor-ceiling assemblies, doors, windows, roofs, panels, and other space-dividing elements.

1.2 *Laboratory Accreditation*—A procedure for accrediting a laboratory for performing this test method is given in Annex A3.

1.3 *This standard does not purport to address all of the safety concerns, if any, associated with its use. It is the responsibility of the user of this standard to establish appropriate safety and health practices and determine the applicability of regulatory limitations prior to use.*

## 2. Referenced Documents

### 2.1 *ASTM Standards:*<sup>2</sup>

- C 634 Terminology Relating to Environmental Acoustics
- E 336 Test Method for Measurement of Airborne Sound Insulation in Buildings
- E 413 Classification for Rating Sound Insulation

E 492 Test Method for Laboratory Measurement of Impact Sound Transmission Through Floor-Ceiling Assemblies Using the Tapping Method

E 597 Practice for Determining a Single-Number Rating of Airborne Sound Isolation for Use in Multiunit Building Specifications

E 966 Guide for Field Measurement of Airborne Sound Insulation of Building Facades and Facade Elements

E 1007 Test Method for Field Measurement of Tapping Machine Impact Sound Transmission through Floor-Ceiling Assemblies and Associated Support Structures

E 1289 Specification for Reference Specimen for Sound Transmission Loss

E 1332 Classification for Determination of Outdoor-Indoor Transmission Class

E 1375 Test Method for Measuring the Interzone Attenuation of Furniture Panels Used as Acoustical Barriers

E 1408 Test Method for Laboratory Measurement of the Sound Transmission Loss of Door Panels and Door Systems

E 1414 Test Method for Airborne Sound Attenuation Between Rooms Sharing a Common Ceiling Plenum

E 2235 Test Method for Determination of Decay Rates for Use in Sound Insulation Test Methods

### 2.2 *ANSI Standards:*

S1.4 Specification for Sound-Level Meters<sup>3</sup>

S1.6 Standard Preferred Frequencies, Frequency Levels, and Band Numbers for Acoustical Measurements<sup>3</sup>

<sup>1</sup> This test method is under the jurisdiction of ASTM Committee E33 on Environmental Acoustics and is the direct responsibility of Subcommittee E33.03 on Sound Transmission.

Current edition approved April 1, 2004. Published May 2004. Originally approved in 1955. Last previous edition approved 2002 E 90 – 02.

<sup>2</sup> *Annual Book of ASTM Standards*, Vol 04.06.

For referenced ASTM standards, visit the ASTM website, [www.astm.org](http://www.astm.org), or contact ASTM Customer Service at [service@astm.org](mailto:service@astm.org). For *Annual Book of ASTM Standards* volume information, refer to the standard's Document Summary page on the ASTM website.

<sup>3</sup> Available from the American National Standards Institute, 11 W. 42nd St., 13th Floor, New York, NY 10036.

S1.10 Pressure Calibration of Laboratory Standard Pressure Microphones<sup>3</sup>

S1.11 Specification for Octave-Band and Fractional-Octave-Band Analog and Digital Filters<sup>3</sup>

S12.31 Precision Methods for the Determination of Sound Power Levels of Broad-Band Noise Sources in Reverberation Rooms<sup>3</sup>

2.3 ISO Standards:

ISO 717 Rating of Sound Insulation for Dwellings<sup>3</sup>

ISO 3741 Acoustics—Determination of Sound Power Level of Noise Sources—Precision Methods for Broad-Band Sources in Reverberation Rooms<sup>3</sup>

3. Terminology

3.1 The following terms used in this test method have specific meanings that are defined in Terminology C 634.

- acoustical barrier
- airborne sound
- average sound pressure level
- background noise
- damp
- decay rate
- decibel
- diffraction
- diffuse sound field
- direct sound field
- flanking transmission
- level
- octave band
- pink noise
- receiving room
- reverberant sound field
- reverberation room
- sabin
- sound absorption
- sound attenuation
- sound energy
- sound insulation
- sound isolation
- sound level
- sound power
- sound pressure
- sound pressure level
- sound transmission level
- sound transmission class
- sound transmission coefficient
- sound transmission loss
- source room
- unit

3.1.1 For the purposes of this test method, transmission loss is operationally defined as the difference in decibels between the average sound pressure levels in the reverberant source and receiving rooms, plus ten times the common logarithm of the ratio of the area of the common partition to the sound absorption in the receiving room (see Eq 11).

NOTE 1—Sound transmission coefficient and sound transmission loss are related by either of the two equations:

$$TL = 10 \log(1/\tau) \tag{1}$$

$$\tau = 10^{-TL/10} \tag{2}$$

3.2 Definitions of Terms Specific to This Standard:

3.2.1 *sound absorption, A, [L<sup>2</sup>]*—of a room, in a specified frequency band, the hypothetical area of a totally absorbing surface without diffraction effects which, if it were the only absorbing element in the room, would give the same sound decay rate as the room under consideration.

4. Summary of Test Method

4.1 Two adjacent reverberation rooms are arranged with an opening between them in which the test partition is installed. Care is taken that the only significant sound transmission path between rooms is by way of the test partition. An approximately diffuse sound field is produced in one room, the source room. Sound incident on the test partition causes it to vibrate and create a sound field in the second room, the receiving room. The space- and time-averaged sound pressure levels in the two rooms are determined (see Fig. 1). In addition, with the test specimen in place, the sound absorption in the receiving room is determined. The sound pressure levels in the two rooms, the sound absorption in the receiving room and the area of the specimen are used to calculate transmission loss as shown in Section 12. Because transmission loss is a function of frequency, measurements are made in a series of frequency bands.

4.2 Additional procedures that may be followed when testing doors are given in Test Method E 1408.

5. Significance and Use

5.1 Sound transmission loss as defined in Terminology C 634, refers to the response of specimens exposed to a diffuse incident sound field, and this is the test condition approached by this laboratory test method. The test results are therefore most directly relevant to the performance of similar specimens exposed to similar sound fields. They provide, however, a useful general measure of performance for the variety of sound fields to which a partition or element may typically be exposed.

5.2 This test method is not intended for field tests. Field tests should be performed according to Test Method E 336.

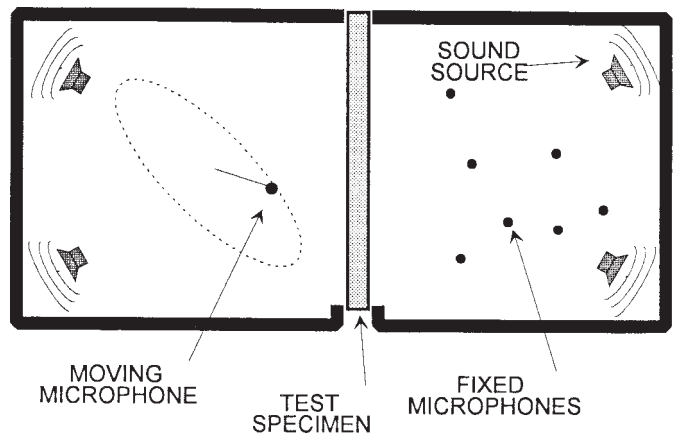

FIG. 1 Illustration showing conceptual arrangement of a wall sound transmission loss suite. This figure is not meant to be a design guide but is for illustrative purposes only. As an example, the room on the right has fixed microphones to measure average sound pressure level; the room on the left has a continuously moving microphone to measure average sound pressure level. Usually both rooms will have the same microphone system. The sound sources (loudspeakers) in the rooms generate the incident sound fields for the measurement of level differences or of sound decay rates. As shown, either room could serve as source or receiving room.

## 6. Test Rooms

6.1 *Room Size and Shape*—To produce an acceptable approximation to the assumed diffuse sound fields, especially in the lowest test frequency band, the sound fields in the rooms must satisfy the requirements in Annex A2. They must also satisfy any of the following requirements that are mandatory.

6.1.1 *Minimum Volume*—The volume of the source and receiving rooms must each be 50 m<sup>3</sup> (1765 ft<sup>3</sup>) or more.

6.2 *Room Absorption*—The sound absorption in each of the rooms should be made as low as possible to achieve the best possible simulation of the ideal diffuse field condition and to keep the region dominated by the direct field (of the source or of the test specimen) as small as possible (see 8.5). At each frequency, the sound absorption for each room (as furnished with diffusers) should be no greater than:

$$A = V^{2/3}/3 \quad (3)$$

where:

$V$  = room volume, and

$A$  = sound absorption of the room.

When  $V$  is expressed in cubic metres,  $A$  is in square metres. When  $V$  is expressed in cubic feet,  $A$  is in sabin (square feet). At low frequencies somewhat higher room absorption may be desirable to accommodate other test requirements (for example, ANSI S12.31, ISO 3741). Sound absorption in the room is usually increased at frequencies below  $f = k_2/V^{1/3}$  ( $k_2$  is an empirical constant equal to 2000 m/s when  $V$  is in cubic metres, and equal to 6562 ft/s when  $V$  is in cubic feet). In any case, the sound absorption should be no greater than three times the value given by Eq 3. For frequencies above 2000 Hz, atmospheric absorption may make it impossible to avoid a slightly higher value than that given in Eq 3.

6.2.1 Unless otherwise specified, the average temperatures in each room during all acoustical measurements shall be in the range  $22 \pm 5^\circ\text{C}$ .

6.2.2 When testing specimens that are windows or window systems, the average temperature of the specimen and in each room during all acoustical measurements shall be in the range  $22 \pm 2^\circ\text{C}$ .

NOTE 2—The sound damping properties of viscoelastic materials used to mount glass often depends on temperature. This requirement minimizes any effects this has on measured sound transmission loss.

6.2.3 During the sound pressure level and sound absorption measurements, variations in temperature and humidity in the receiving room shall not exceed  $3^\circ\text{C}$  and 3% relative humidity respectively. Temperature and humidity shall be measured and recorded at the beginning and end of each test to ensure compliance.

6.3 *Methods to Reduce the Variability of the Sound Fields*—Meeting the requirements of 6.1 and 6.2 can be difficult in the lower test bands where results are likely to depend critically on arbitrary features of the test geometry such as positioning of the sound sources and individual microphones. Spatial variations in sound pressure level and decay rate may be reduced by one or both of the following types of diffusing panels. The recommendations that follow are only included as guidelines.

Satisfaction of the requirements of Annex A2 for confidence intervals is the primary criterion, not the size or number of diffusing panels.

6.3.1 *Stationary Diffusing Panels*—It is recommended that each test room be fitted with a set of about 3 to 6 diffusing panels, suspended in random orientations throughout the room space. The appropriate number, distribution, and orientation of panels should be determined experimentally by checking to see if spatial variances of sound pressure level or decay rate are reduced. Lateral panel dimensions should be about  $\frac{1}{2}$  to 1 wave-length of the sound at the lowest test band, for example, about 1.2 to 2.5 m. The recommended minimum mass per unit area of the panels is 5 kg/m<sup>2</sup> (1 lb/ft<sup>2</sup>) for operation down to 100 Hz. (Panels of plywood or particleboard measuring 1.2 × 2.4 m are often used.) To be effective at lower frequencies, the size and mass of diffusing panels should be increased in proportion to the wavelength. It is likely to be impractical to use very large diffusing panels at very low frequencies; they might make the room behave like a number of coupled spaces rather than a single room, and it might be difficult to position microphones.

6.3.2 *Rotating or Moving Diffusers*—One or more rotating or moving panels set at oblique angles to the room surfaces may be installed in either or both rooms. The recommendations for weight and size of the panels given in 6.3.1 for fixed diffusing panels apply also to rotating or moving diffusers. The panels should be large enough that during motion they produce a significant variation in the sound field, yet small enough that they do not effectively partition the room at any point in their movement.

NOTE 3—Moving diffusers can generate mechanical noise or wind and wind noise in microphones. This increased background noise may make measurements difficult in some cases.

6.4 *Flanking Transmission*—The test rooms shall be constructed and arranged to minimize the possibility of transmission by paths other than that through the test partition. Sound pressure levels produced by such flanking transmission should be at least 10 dB lower than the sound radiated into the receiving room by the test partition. Supporting one or both rooms on vibration isolators (resilient materials or springs) is a common method of reducing flanking transmission. Structural discontinuities are recommended between the source-room and the test specimen and between the receiving room and the test specimen to minimize flanking transmission between them.

NOTE 4—If the specimen is rigidly connected to the source-room structure, there is some risk that, in addition to the incident airborne sound, sound power may enter the specimen at the edges because of vibration of the source-room structure. Similarly, if the specimen is rigidly connected to the receiving room structure, sound power may flow from the specimen to the walls of the receiving room and be radiated from them.

6.4.1 The limit on specimen transmission loss measurement due to flanking transmission must be investigated as follows:

6.4.1.1 In the test opening, build a partition expected to have high transmission loss.

6.4.1.2 Measure the transmission losses following this test method.

6.4.1.3 Increase the expected transmission losses by making a substantial improvement to the test partition, for example, by adding a heavy shielding structure in front of the test partition.

6.4.1.4 Measure the transmission loss again.

6.4.1.5 Repeat steps 6.4.1.3 and 6.4.1.4 until significant additions to the test partition no longer significantly increase the measured transmission loss. The sound transmission loss measured can then be ascribed to flanking paths. The transmission loss values obtained represent the limit that can be measured by the facility. Unless steps are taken to eliminate them, these paths always exist and will reduce the measured transmission loss for partitions whose inherent transmission loss values are within 10 dB of the flanking limit. The sound power transmission along a particular suspected flanking path may be decreased to determine if the measured transmission loss increases. This may be done by temporarily adding shielding structures in front of the surfaces that are suspected of radiating unwanted sound.

6.4.2 A potential flanking path is through the perimeter of the partition or the mounting frame (1).<sup>4</sup> It is therefore important that the partition mounting arrangement used in determining the transmission loss limit be the same as is used for routine testing.

6.4.3 An extraneous signal similar in effect to flanking transmission may be produced by electrical “cross-talk” between the electrical system driving the sound source or other devices and the receiving microphone systems. This possibility should be checked, whenever systems are changed, by measuring the residual signals when the loudspeaker is replaced by an equivalent electrical load or by replacing the microphone cartridge with a dummy load.

6.4.4 Laboratories must keep records of data collected to establish the flanking limit of their facilities.

6.4.5 When the transmission loss measured for a test specimen in a particular frequency band is within 10 dB of the flanking limit established for the laboratory, the transmission loss value must be clearly identified in the test report as being potentially limited by the laboratory. The true value may be higher than that measured.

## 7. Test Specimens

7.1 *Size and Mounting*—Any test specimen that is to typify a wall or floor shall be large enough to include all the essential constructional elements in their normal size, and in a proportion typical of actual use. The minimum dimension (excluding thickness) shall be 2.4 m, except that specimens of doors, office screens, and other smaller building elements shall be their customary size. Preformed panel structures should include at least two complete modules (panels plus edge mounting elements), although single panels can be tested. In all cases the test specimen shall be installed in a manner similar to actual construction, with a careful simulation of normal constraint and sealing conditions at the perimeter and at joints within the

field of the specimen. Detailed procedures for particular types of building separation elements are recommended in Annex A1.

7.2 *Aging of Specimens*—Test specimens that incorporate materials for which there is a curing process (for example adhesives, plasters, concrete, mortar, damping compound) shall age for a sufficient interval before testing. Manufacturers may supply information about curing times for their products. Aging periods for certain common materials are given in Annex A1.

7.2.1 For materials whose aging characteristics are not known, tests shall be repeated over a reasonable time on at least one specimen to determine an appropriate aging period. A suggested procedure is to test at intervals in the series 1, 2, 4, 7, 14, and 28 days from the date of construction, until no significant change is observed between successive tests. The minimum aging period should be the interval beyond which no significant change is observed.

7.2.1.1 To decide whether a change is significant, laboratory operators must determine the repeatability of their test procedures. This is done by repeating the complete test procedure several times without disturbing the specimen or other apparatus and with as little time as possible between repeat measurements. From the set of transmission loss measurements, calculate the standard deviation of transmission loss at each frequency. Standard statistical techniques (2) may then be used to decide if a test differs significantly from a previous test. In many cases, a visual comparison of two results will be enough to verify that there is no significant difference between two results.

7.3 *Testing of Specimens Smaller Than Test Opening*—When the area of the test specimen is smaller than that of the normal test opening, the area of the test opening must be reduced using additional construction. This additional construction, or filler wall, should be designed to transmit as little sound as possible. Nevertheless, a portion of the sound may be transmitted by way of the filler wall (see Fig. 2). Sound transmission through the composite wall can be represented by:

$$\tau_{cS_c} = \tau_s S_s + \tau_f S_f \quad (4)$$

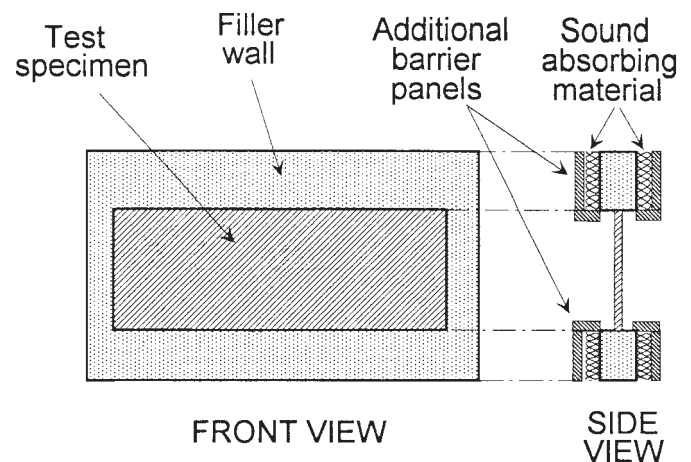

FIG. 2 Illustration showing filler wall and test specimen that is smaller than the test opening. This figure is not meant to be a design guide but is for illustrative purposes only. The side view shows the application of additional panels as discussed in 7.3.2.

<sup>4</sup> The boldface numbers in parentheses refer to the list of references at the end of this test method.



or

$$\tau_s = (\tau_c S_c - \tau_f S_f) / S_s \quad (5)$$

where:

- $S_c$  = area of composite construction ( $S_c = S_s + S_f$ ),
- $S_s$  = area of test specimen,
- $S_f$  = area of filler element,
- $\tau_c$  = transmission coefficient of composite construction,
- $\tau_s$  = transmission coefficient of test specimen, and
- $\tau_f$  = transmission coefficient of filler element.

NOTE 5—The above expressions assume that the two parts of the composite construction react to the sound field independently of each other.

Two general procedures may be used to deal with this situation:

**7.3.1 Build and Measure a Complete Filler Wall**—This is the preferred method and is usually most convenient when the specimen area is smaller than the area of the filler wall. Based on experience and knowledge of the test specimen construction, build a filler wall that is expected to transmit a negligible amount of sound relative to that through the specimen. The filler wall should be built with support structures for the test specimen already in place. The opening for the specimen shall be closed and finished with the same construction as the rest of the filler wall, except as noted in 7.3.2.

**7.3.1.1** Following the procedures in this test method, measure the sound transmission losses for this complete filler wall. The transmission coefficients,  $\tau_f$ , for the filler wall can be calculated from the corresponding transmission losses using Eq 2.

**7.3.1.2** Remove the part of the filler wall surfaces covering the opening for the specimen and install the specimen. Make no other significant changes to the filler wall structure.

**7.3.1.3** Following the procedures in this test method, measure the sound transmission losses for this composite wall. The transmission coefficients,  $\tau_c$ , can be calculated from the corresponding transmission losses using Eq 2. The area used in calculation is the combined area of the specimen and the filler wall,  $S_c$ .

**7.3.1.4** At each test frequency calculate the difference:  $10 \log(\tau_c S_c) - 10 \log(\tau_f S_f)$ .

**7.3.1.5** If the difference is more than 15 dB, calculate  $\tau_s$  from Eq 5 ignoring the term  $\tau_f S_f$ .

**7.3.1.6** If the difference is between 6 and 15 dB, calculate  $\tau_s$  using Eq 5. This corrects for transmission through the filler wall. Note in the test report where such corrections have been made.

**7.3.1.7** If the difference is less than 6 dB, reliable corrections cannot be made. Calculate  $\tau_s$  from Eq 5 ignoring the term  $\tau_f S_f$ . Multiply the value obtained by 0.75 and then use Eq 1 to calculate a lower limit for the transmission loss of the test specimen. (This is equivalent to limiting the difference to 6 dB.) Any values of transmission loss that are limited in this way must be clearly marked as such in the test report.

**7.3.2 Use Additional Structures to Reduce Transmission**—Some test specimens fill a large fraction of the test opening leaving only a small area for a filler wall. In such cases, it is not always convenient to construct and test a complete filler wall

and the transmission coefficient of the filler wall is not known. To demonstrate that transmission through the filler wall is negligible, proceed as follows:

**7.3.2.1** Measure the sound transmission loss for the composite assembly.

**7.3.2.2** Cover each face of the filler wall with sound absorbing material at least 50 mm (2 in.) thick. Cover the sound absorbing material with barrier panels weighing at least 8 kg/m<sup>2</sup> (1.6 lb/ft<sup>2</sup>) that are not rigidly attached to the filler wall (see Fig. 2). Normal good practices should be followed for mounting and sealing.

**7.3.2.3** Remeasure the sound transmission loss for the composite assembly.

**7.3.2.4** If changes are insignificant, it may be assumed that transmission through the filler wall is negligible.

**7.3.3** Other combinations of test specimen and filler wall may require other procedures. It is the responsibility of the testing laboratory to show that transmission through filler walls is negligible.

**7.3.4** When a small specimen such as a door or window assembly is mounted in a filler wall, the distance from the surface of the filler wall to the specimen surface should be small compared to the lateral dimensions of the specimen.

**7.3.5** When a filler wall is used, ensure that sound is not transmitted through the structure where the filler wall and the test specimen join. Such flanking can occur when the filler wall is thicker than the test specimen.

**7.4 Office Screens**—The minimum area of an office screen specimen shall be 2.3 m<sup>2</sup> (25 ft<sup>2</sup>). Testing an office screen according to this test method is only appropriate when the property of interest is sound transmission through the main body of the screen. Screens that incorporate electrical raceways may allow sound to pass through easily in this region. Such parts of an office screen should be included as part of the specimen. For a complete test of the screen as a barrier, including the effects of diffraction and leakage, Test Method E 1375 is recommended.

**7.5 Operable Door Systems**—Measurements may be in accordance with Test Method E 1408 to evaluate door systems in the operable and fully sealed state, and to measure the force required to operate the door.

## 8. Test Signal Sound Sources

**8.1 Signal Spectrum**—The sound signals used for these tests shall be random noise having a continuous spectrum within each test frequency band.

**8.2 Sound Sources**—Sound is usually generated in the rooms using loudspeaker systems although other sources are acceptable if they satisfy the requirements of this test method.

**8.2.1** Sources should preferably be omnidirectional at all measurement frequencies to excite the sound field in the room as uniformly as possible. Using separate loudspeakers for high and low frequencies will make the system more omnidirectional. The direct field from the loudspeaker system can be further reduced by aiming the loudspeakers into corners of the room. Laboratory operators may also find that this orientation increases the low frequency sound pressure levels in the room.

Another approach to obtaining an omnidirectional speaker system is to use an array of loudspeakers mounted on the faces of a dodecahedron.

### 8.2.2 Orientation of Loudspeakers:

8.3 *Multiple Sound Source Positions*— Measured values of sound transmission loss, especially at low frequencies, may change significantly when a loudspeaker position is changed in the source room. Where this occurs, sound transmission loss should be measured for several loudspeaker positions and the values averaged to provide a less biased result. Sound sources can be used either in sequence or simultaneously. If they are used simultaneously, they must be driven by separate random noise generators and amplifiers. Multiple, uncorrelated sound sources have also been found to reduce the spatial variance of sound pressure level in reverberation rooms.

8.4 *Location of Sound Sources*—Sound source positions shall be selected to minimize spatial fluctuations in the reverberant field in the source room; sources in trihedral corners of the room excite room modes more effectively.

8.5 *Direct Field of Sound Source(s)*— The direct sound field from the source(s) at the test partition, or the nearest microphone shall be at least 10 dB below the sound pressure level of the reverberant field. The distance between the source(s) and the partition or microphones required to achieve this condition will depend on the room properties, the number and orientation of sound sources and frequency. Verify that the distances between a single source and the microphones and test partition satisfy the relationship:

$$r \geq \frac{1}{4} \sqrt{\frac{10A}{\pi}} \quad (6)$$

where:

$A$  = sound absorption in the room, and  
 $r$  = distance from the source.

When  $A$  is in square metres,  $r$  is in metres. When  $A$  is in sabins (square feet),  $r$  is in feet.

NOTE 6—This expression is for a point source and is obtained by determining the point where the sound pressure level of the direct field is 10 dB below the sound pressure level of the reverberant field (3). The expression is thus not strictly accurate for loudspeaker systems especially at high frequencies where the directivity index is greater than unity. Neither is it accurate when multiple sources are used, but, for the purposes of this test method, it is deemed acceptable.

## 9. Microphone Requirements

9.1 Microphones are used to measure average sound pressure levels in the rooms and sound decay rates in the receiving room. Various systems of data collection and processing are possible, ranging from a single microphone moving continuously or placed in sequence at several measurement positions to several microphones making simultaneous measurements (see Fig. 1 for two examples). The measurement process must account for level fluctuations caused by spatial and temporal variations. Microphone sensitivity and moving diffusers must also be accounted for.

9.2 *Microphone Electrical Requirements*— Use microphones that are stable and substantially omnidirectional in the frequency range of measurement. (A 13-mm (0.5-in.) random-incidence condenser microphone is recommended.) Specifi-

cally, microphones, amplifiers, and electronic circuitry to process microphone signals must satisfy the requirements of ANSI S1.4 for Type 1 sound level meters, except that A, B, and C weighting networks are not required since one-third octave filters are used. Where multiple microphones are used, they should be of the same model.

9.3 *Calibration*—Calibrate each microphone over the whole range of test frequencies as often as necessary to ensure the required accuracy (see ANSI S1.10). A record shall be kept of the calibration data and the dates of calibration. Calibration checks of the entire measurement system for at least one frequency shall be made at least once during each day of testing.

9.3.1 Make the sensitivity check of the measurement system using an acoustic or electrostatic calibrator that is known to be stable. The sensitivity check will usually consist of impressing a known sound pressure upon the microphone system, keeping account of all variable gain settings in the equipment. This procedure establishes a relationship between electrical output and sound pressure level at the microphone. All subsequent electrical outputs can thus be converted to sound pressure levels at the microphone, taking into account the filter response and any changes of gain in the system.

9.4 *Microphone Positions*—For rooms and test signals that conform to this test method, the sound pressure level will be nearly the same at all positions within a restricted space delineated in 9.4.1-9.4.4. Greater variance in measured data will be found at lower frequencies. Nevertheless, variations in the level of the reverberant sound field are still significant and measurements must be made at several positions in each room to sample adequately the sound field. A moving microphone is one convenient way of doing this. The system adopted for the measurement of average sound pressure levels must produce results that meet the requirements of Annex A2. For all microphone systems, microphones must be located according to the following restrictions:

9.4.1 The shortest distance from any microphone position to any major extended surface shall be greater than 1 m. The same limit applies relative to any fixed diffuser surface (excluding edges) and relative to any possible position of a rotating or moving diffuser.

9.4.2 For this test method, stationary microphone positions shall be at least 1.5 m apart. Rotating microphones shall trace a circle at least 1.2 m in radius.

NOTE 7—If estimates of the confidence interval of average sound pressure level are to be reliable, microphone positions should be sufficiently far apart to provide independent samples of the sound field. For fixed microphones, this requires that they be spaced at least half a wavelength apart (4). For a moving microphone see Annex A2.

9.4.3 In the source room, no microphone shall be so close to any source as to be affected significantly by its direct field (see 8.5).

9.4.4 In the receiving room, microphones shall be more than 1.5 m from the test partition. This is to reduce the influence of the direct field of the specimen.

9.5 *Number of Stationary Microphone Positions or Size of Microphone Traverse*—Procedures for determining an acceptable number of microphone positions or the size of a microphone traverse are described in detail in Annex A2.

## 10. Frequency Range and Bandwidth for Analysis

10.1 *Bandwidth*—For each test band, the overall frequency response of the electrical system, including the filter or filters in the source or microphone systems, shall satisfy the specifications given in ANSI Specification S1.11 for a one-third octave band filter set, Order 3 or higher, Type 1.

10.1.1 Filtering may be done either in the source or measurement system or partly in both, if the required overall characteristic is achieved. Besides defining the one-third-octave bandwidth of test signals, filters in the microphone system reduce extraneous noise lying outside the test bands, including possible distortion in the source system; a filter in the source system serves to concentrate the available power in one test band or a few bands.

10.2 *Standard Test Frequencies*—Measurements shall be made in all one-third-octave bands with mid-band frequencies specified in ANSI S1.6 from 100 to 5000 Hz. For sound transmission loss measurements on building facades, exterior doors or windows, or other building facade elements where the outdoor-indoor transmission class is to be calculated, the minimum frequency range shall be from 80 to 5000 Hz. It is desirable in any case that the frequency range be extended to include bands below 125 Hz. Many applications require information on low frequency transmission loss and laboratory operators are encouraged to collect and report information down to at least 63 Hz where feasible. Note that larger room volumes are recommended when measuring at lower frequencies (see section X2.4).

## 11. Procedure

11.1 *Measurement of Average Sound Pressure Levels,  $\langle L_1 \rangle$  and  $\langle L_2 \rangle$* —With the sound sources generating the sound field in the source room, and microphone positions in accordance with 9.3.1, measure the space- and time-averaged sound pressure level in the source room,  $\langle L_1 \rangle$ , and the receiving room,  $\langle L_2 \rangle$  using averaging times as follows:

11.2 *Averaging Time, Stationary Microphones*—For each sampling position, the averaging time shall be sufficient to yield an estimate of the time-averaged level to within  $\pm 0.5$  dB. This requires longer averaging times at low frequencies than at high. For 95 % confidence limits of  $\pm e$  dB in a one-third octave band with mid-band frequency,  $f$ , the integration time,  $T$ , may be estimated from:

$$T = \frac{310}{fe^2} \quad (7)$$

Thus at 125 Hz, the minimum averaging time for confidence limits of  $\pm 0.5$  dB should be 9.9 s. At 100 Hz, an averaging time of 12.4 s is needed. For more information see Ref (5).

11.2.1 If a moving or rotating diffuser is used, determine the average sound pressure level at each microphone position during an integral number of diffuser cycles. Alternatively, average over a time so long that contributions from fractions of a diffuser cycle are negligible.

11.2.2 *Averaging Time, Moving Microphones*—The averaging time for a moving microphone should be long enough that differences between repeat measurements are negligibly small. A typical averaging time around the traverse is 60 s but operators should determine acceptable times by experiment.

11.2.2.1 Note that if both moving microphones and moving vanes are used, their periods of rotation and displacement and the averaging time should be chosen so each observation adequately samples all the possible combinations of microphone and vane positions.

11.3 *Background Noise in the Receiving Room and Associated Measurement System*—With the sound sources not operating, measure the background noise levels in the receiving room for each frequency band at the same microphone positions used to measure  $\langle L_2 \rangle$ . Make these measurements using the same microphone and analyser gain settings as used for measurements of the received level. This accounts properly for residual noise and the dynamic range in instrumentation. At each measurement position corrections must be made unless the background level is more than 10dB below the combination of signal and background. (The signal is the sound pressure level due to the transmission through the test specimen.) If the background level is between 5 and 10 dB below the combined level, correct the signal level. At each measurement position corrections must be made unless the background level is more than 10 dB below the combination of signal and background. (The signal is the sound pressure level due to transmission through the test specimen.) If the background level is between 5 and 10 dB below the combined level, correct the signal level using:

$$L_s = 10 \log[10^{L_{sb}/10} - 10^{L_b/10}] \quad (8)$$

where:

$L_b$  = background noise level, dB,

$L_{sb}$  = level of signal and background combined, dB, and

$L_s$  = adjusted signal level, dB.

NOTE 8—When the background noise measurements described in 11.3 give values higher than the typical background noise measured in accordance with X1.4.1.9 in the Appendix, it is an indication that the transmission loss measurement are limited by the residual noise and dynamic range of the instrumentation rather than the background noise in the receiving room due to acoustic sources in the test laboratory.

11.3.1 If the output of the sound sources cannot be increased so the combined level is at least 5 dB above the background level, then subtract 2 dB from the combined level and use this as the corrected signal level. In this case, the measurements can be used only to provide an estimate of the lower limit of the sound transmission loss. Identify such measurements in the test report.

NOTE 9—Noise measured by the microphone system in the receiving room when the sound sources are not operating may be due to extraneous acoustical sources or to electrical noise in the receiving system, or both.

11.4 *Determination of Receiving Room Absorption,  $A_2$* —Measure the mean value of the receiving room absorption at each frequency in accordance with Test Method E 2235. level in the room. The determination of  $A_2$  shall be made with the receiving room in the same condition as for the measurement of  $\langle L_1 \rangle$  and  $\langle L_2 \rangle$  (see 11.1). Specifically, the test specimen



shall remain in place so its effective absorption (which includes transmission back to the source room) is included. Sound sources used for measuring  $A_2$  shall be present during the measurement of  $\langle L_2 \rangle$ , so their absorption is present during both measurements.

11.4.1 The speed of sound changes with temperature and it shall be calculated for the conditions existing at the time of test from the equation:

$$c = 20.047 \sqrt{273.15 + t} \text{ m/s} \quad (9)$$

where:

$t$  = receiving room temperature, °C.

11.4.2 *Room Coupling*—Because the two test rooms are coupled by the test specimen, it is possible that the decay rate measurements in the receiving room will be influenced by sound energy transmitted into the source room and then back again during the decay process (6). Decay curves may be markedly curved or have two pronounced slopes. The effect will be small if  $\tau S$  is small compared to  $A_1$ , the absorption in the source room, or  $A_2$ , the absorption in the receiving room, or if  $d_1/d_2$ , the ratio of decay rates in the two rooms, is sufficiently large. The latter requirement may be met by adding absorption to the source room until no further effect is observed on the measured value of  $d_2$ .

NOTE 10—Additional absorption in the source room is required only during measurement of receiving room absorption. It should not be present during measurement of  $\langle L_1 \rangle$  and  $\langle L_2 \rangle$ .

## 12. Calculation

12.1 *Calculation of Space-Averaged Levels, Stationary Microphones*—Following the procedures of 11.1 and 11.2, two sets of sound pressure levels, corresponding to the sampling positions in the two rooms, will be obtained for each frequency band.

12.1.1 For each frequency band calculate the space-averaged level corresponding to each set using:

$$\langle L \rangle = 10 \log \left[ \frac{1}{n} \sum_{i=1}^n 10^{L_i/10} \right] \quad (10)$$

where:

$L_i$  = one set of time-averaged levels taken at  $n$  locations.

NOTE 11—The convention used in this test method is that if  $X$  is the symbol for a physical quantity,  $\log X$  denotes the common logarithm of the numerical value of the quantity.

12.2 Calculate the sound transmission loss from:

$$TL = \langle L_1 \rangle - \langle L_2 \rangle + 10 \log S/A_2 \quad (11)$$

where:

$TL$  = transmission loss, dB,

$\langle L_1 \rangle$  = average sound pressure level in the source room, dB,

$\langle L_2 \rangle$  = average sound pressure level in the receiving room, dB,

$S$  = area of test specimen that is exposed in the receiving room,  $m^2$ , and

$A_2$  = sound absorption of the receiving room with the test specimen in place,  $m^2$  (7).

NOTE 12— $S$  and  $A_2$  may be expressed in square feet so long as both are.

12.3 This test method specifies the use of one-third octave bands for measurement and calculation of sound transmission loss. It does not allow measurement of octave band transmission losses because these are very sensitive to the shape of the spectrum in the source room and to the details of the transmission loss characteristics of the test panel. In applications where octave band transmission loss values,  $TL_{oct}$ , are required, they must be calculated using the expression:

$$TL_{oct f_c} = -10 \log \left[ \frac{1}{3} \sum_{B=B_c-1}^{B_c+1} 10^{-TL_B/10} \right] \quad (12)$$

where:

$f_c$  = preferred octave band mid-band frequency as specified in ANSI S1.6.

12.3.1 The summation is made over three one-third octave band TL values: one at the frequency  $f_c$  with band number  $B_c$  and the adjacent one-third octave bands, with band numbers  $B_c + 1$  and  $B_c - 1$ . The octave band transmission loss values calculated from this expression approximate what would be measured if the spectrum in the source room had the same sound pressure level in each one-third octave band. (Random noise with this spectrum is known as “Pink noise.”)

## 13. Report

13.1 Include the following information in the test report:

13.1.1 A statement, if true in every respect, that the tests were conducted according to this test method and that data for flanking limit tests and reference specimen tests are available on request. Conformance to the relevant sections of Annex A1 shall also be reported when applicable.

13.1.2 A description of the test specimen. The description must be sufficiently detailed to identify the specimen, at least for those elements that may affect its sound transmission loss, unless the test sponsor wishes to withhold information of a proprietary nature. The specimen size, including thickness, and the average mass per unit area shall always be reported. Wherever possible, the testing laboratory should observe and report the materials, dimensions, masses per unit area or densities, and other relevant physical properties of the major components. A description of the methods used to combine the components, the fastening elements used, (type of screws, nails or glue etc.) and the spacing between them should also be given. A designation and description furnished by the sponsor of the test may be included in the report provided that they are attributed to the sponsor. If some details of the specimen construction are withheld at the sponsor’s request, the report shall state this. The curing period, if any, and the condition of the specimen as tested (shrinkage, cracks, etc.) shall be reported.

13.1.3 A description of the method of installation of the specimen in the test opening, including the location of framing members relative to the edges, and the treatment of the junction with the test opening. The use and type of caulking, gaskets, tape, or other sealant on perimeter or interior joints shall be carefully described.

13.1.4 The dates of construction and testing.

13.1.5 If the test specimen is a screen, include a statement, if true, that sound transmission through raceways and other penetrations are included in the evaluation.



13.1.6 Sound transmission losses rounded to the nearest decibel for the frequency bands required in 10.2 and any other bands measured.

13.1.6.1 Identify data affected by flanking transmission or background noise.

13.1.7 If results are presented in graphical form, the abscissa length for a 10:1 frequency ratio should equal the ordinate length for 25 dB. Whenever practical, the scales should be 50 mm for a 10:1 frequency ratio and 20 mm for 10 dB, and the ordinate scale should start at 0 dB.

13.1.8 The temperature and humidity in the rooms during the measurements.

13.1.9 The volumes of the test rooms.

13.1.10 The confidence limits found for the laboratory as described in Annex A2 either during the actual test or in separate measurements.

13.1.11 *Single Number Ratings*:

13.1.11.1 *Sound Transmission Class*—If single number ratings are given, the sound transmission class described in Classification E 413 shall be included.

NOTE 13—The airborne sound reduction index described in ISO 717 is a similar rating that may also be given.

13.1.11.2 *Outdoor-Indoor Transmission Class*—Where the test specimen may be used as part of a facade of a building, the Outdoor-Indoor transmission class should be included. This

single number rating is intended to rate the effectiveness of building facade elements at reducing transportation noise intrusion. The rating is described in Classification E 1332.

## 14. Precision and Bias

14.1 *Precision*—Measurements at one laboratory show that the repeatability standard deviation for complete rebuilds of wood joist floor ranged from about 1.5 to 3.5 dB in the frequency range 125 to 4 kHz. This repeatability includes normal variations in materials but minimal changes in construction techniques. The repeatability standard deviation for re-installation of a concrete slab was about 4.5 dB at 100 Hz and below, about 3dB from 125 to 630Hz, and about 1.5 dB above 630 Hz. Repeatability for this test method depends on the specimen type and not enough data have been collected to allow more specific statements. From round robin testing on copies of the reference specimen described in Specification E 1289, it has been determined that the reproducibility standard deviation is 2dB or less at all frequencies from 125 to 4000Hz.

14.2 *Bias*—There is no bias in this test method since the true value is defined by the test method.

## 15. Keywords

15.1 airborne sound transmission loss; flanking transmission; sound transmission coefficient; sound transmission loss; transmission loss

## ANNEXES

### (Mandatory Information)

#### A1. PREPARATION AND DESCRIPTION OF TEST SPECIMENS

##### A1.1 Scope

A1.1.1 This annex constitutes an interpretation and elaboration, for certain construction elements, of the general requirements given in Sections 7 and 13. Special details are given for the preparation, installation, and aging of test specimens and the reporting of such matters.

NOTE A1.1—If the recommended aging periods seem inappropriate for a particular construction, the repeat test procedure described in 7.2.1 may be used.

A1.1.2 *Composite Construction*—If a test specimen includes more than one type of component, the requirements for each type shall be satisfied. For example, for a concrete block wall to which plaster is applied, the requirements for masonry and plaster must be satisfied.

A1.1.3 *Aging*—Unless otherwise noted below, all aging shall be at a room temperature from 18 to 24°C and a relative humidity from 40 to 70 %.

##### A1.2 Sealants and Adhesives

A1.2.1 Adhesives and materials used to caulk or seal gaps and fissures around the periphery of a specimen shall be listed by brand name and type. Methods of application and approximate dimensions shall be given.

A1.2.2 *Aging*—If significant quantities of caulking or adhesive materials are required and no recommended aging period is given, appropriate procedures to determine the necessary aging period shall be used (see 7.2.1).

##### A1.3 Fasteners

A1.3.1 Where screws, nails, or other fasteners are used, give their type, dimensions, and method of installation. Give also the spacing between fasteners around the periphery and in the field of the specimen.

##### A1.4 Concrete and Masonry

A1.4.1 *Concrete*—Report the type, thickness, and density of the concrete.

A1.4.2 *Masonry*—Report the materials, dimensions, and average weight of an individual masonry unit. Give the thickness of mortar and describe the materials used in its preparation.

A1.4.3 Determine the mass per unit area of completed concrete or masonry specimens by weighing a representative portion after test or by weighing a small specimen prepared during construction in the same way as the main specimen.

A1.4.4 *Aging*—Following construction, allow concrete or masonry specimens to age a minimum of 28 days before testing (see Note A1.1).

### A1.5 Studs, Joists, Trusses, and Wood or Metal Furring

A1.5.1 *Wood Studs, Joists, and Furring*—State grade of wood, true as well as nominal dimensions, spacing in test opening, fastening conditions, and mass per unit length.

A1.5.2 *Studs or Furring Formed from Sheet Material*—Give manufacturer, model and an accurate description of dimensions and material, preferably in the form of a drawing. Give spacing in test opening, fastening conditions, and mass per unit length.

A1.5.3 *Steel Joists or Wood Trusses*—Give an accurate description of dimensions and material, preferably in the form of a drawing. Give spacing in test opening, fastening conditions, and mass per unit length.

### A1.6 Sound Absorbing Materials

A1.6.1 Specify the material, density, thickness, mass per unit area of wall, location, and method of installation.

### A1.7 Plaster

A1.7.1 *Plaster*—Report the thickness of each layer, the materials used, and the method of application. The actual thickness of plaster layers should be determined, for example, by inspection of representative sections after test. Report the weight per unit area.

A1.7.2 *Lathing*—Report the dimensions of individual sections and orientation in the test specimen, mass per unit area of wall, number and location of fasteners (see Note A1.2), and treatment of edges of specimen.

NOTE A1.2—Resilient fasteners can be short-circuited by plaster that oozes through the lath. If something is done to prevent this or to break the short-circuits, it should be reported.

A1.7.3 *Construction*—The test specimen may either be built into a suitable frame, which is then inserted in the test opening, or built into the opening itself. Report in detail the type of installation and the steps in construction.

A1.7.4 *Aging*—Thick coats of plaster, forming significant contributions to the structure shall age at least 28 days before testing (see Note A1.1). Superficial coats (3 mm (1/8 in.) thick or less) shall age at least 3 days.

### A1.8 Board Materials

A1.8.1 Report the material used, thickness, dimensions of panels, mass per unit area and end, edge, and field fastening conditions.

A1.8.2 *Laminating Adhesives*—Report type of adhesive, method of application, and thickness.

A1.8.3 Gypsum board panels or the complete test specimen shall be conditioned before use or testing by storing for a minimum of 3 days under the conditions in 1.1.3.

A1.8.3.1 If joints are finished with typical joint and finishing compounds, the minimum aging period shall be 12 h.

A1.8.3.2 If laminating adhesives are used, before testing the specimen shall age a minimum of 14 days for water-base adhesives and 3 days for other adhesives.

### A1.9 Demountable Modular Wall Panel Systems

A1.9.1 *Materials and Construction*—The testing laboratory shall report as much physical information as can be determined about the materials and method of assembly of all components of the partition including weights and dimensions of the component parts and the average mass per unit area of the completed partition.

A1.9.2 *Installation*—Installation of the test specimen shall be carried out or observed by the testing laboratory and reported in detail.

### A1.10 Operable (Folding or Sliding) Walls

A1.10.1 *Materials and Construction*—Report as much physical information as can be determined about the materials and method of assembly of all components of the partition including weights and dimensions of the component parts and the average mass per unit area of the completed partition. If the specimen consists of an assembly of panels, the number and dimensions of panels shall be reported. If the specimen is an accordion-type partition, the number of volutes, their spacing, and width when extended, shall be reported. Header construction and dimensions shall be reported. Weights of header and the hanging portion of the door shall be given. Latching and sealing devices shall be fully described.

A1.10.2 *Installation*—Installation of the test specimen shall be carried out or observed by the testing laboratory and reported in detail. Clearances at the perimeter between non-deformable portions of door and frame shall be measured and reported. In particular, any features of the installation that require dimensional control closer than 6 mm (1/4 in.) on the height or width of the test specimen shall be reported.

A1.10.3 *Operation*—The specimen shall not be designated an operable wall unless it opens and closes in a normal manner. It shall be fully opened and closed at least five times after installation is completed and tested without further adjustments.

A1.10.4 The specimen area should include the header and other framing elements if these constitute a portion of the separating partition in a typical installation.

### A1.11 Doors

A1.11.1 Procedures that may be followed when testing doors are given in Test Method E 1408. The specimen shall not be designated a door unless it opens and closes in a normal manner.

## A2. QUALIFICATION OF ROOM SOUND FIELDS AND MICROPHONE SYSTEMS USED FOR SAMPLING

### A2.1 Scope

A2.1.1 One principle underlying this test method is that the reverberant sound fields in the rooms show only small variations with position in the room. In practice, a certain amount of spatial variance must be tolerated and compensated for by correctly sampling the sound fields.

A2.1.2 This annex prescribes procedures for determining whether the sound fields in the rooms and the microphone systems used to sample them give measurement uncertainties that are low enough for the purposes of this test method. This is decided by calculating confidence intervals from measurements of sound pressure level and reverberation time.

A2.1.3 Calculations of confidence intervals do not have to be made for each test, although laboratories can do so if they wish.

### A2.2 Required Confidence Interval for Transmission Loss Measurements

A2.2.1 For any pair of rooms and microphone system, the 95 % confidence interval,  $\Delta TL$ , for transmission loss must be no greater than the values given in the following table:

One-third octave band mid-frequency, Hz	Confidence Interval, $\Delta TL$
80	6
100	4
125, 160	3
200, 250	2
315 to 4000	1

These values should be determined using a specimen with a sound transmission class rating in the 25–50 range. Sound levels in the receiving room should be at least 10 dB above background noise in the room at all frequencies. A suitable specimen is described in Specification E 1289. Confidence intervals that can be attained above and below these frequencies, will depend strongly on the test suite characteristics. Measurement procedures and calculations for calculating confidence limits are given in A2.3.

### A2.3 Measurement Procedures and Calculations

A2.3.1 The confidence interval of a sound transmission loss determination is derived from the confidence intervals for the individual acoustical quantities in Eq 10, namely,  $\langle L_1 \rangle$ ,  $\langle L_2 \rangle$ , and  $A_2$ . (The uncertainty of the measurement of area  $S$  is taken to be zero.) The following paragraphs describe the steps to be taken to collect the data and calculate the confidence intervals for the measurement.

A2.3.2 In each room select a large number (about ten or so) of microphone positions that satisfy the requirements of 9.4. The number of available positions depends on room dimensions and the disposition of diffusers, loudspeakers, and specimen; it may be less than ten. Observing the procedural requirements in the main body of the test method, make the following measurements, preferably using a reference transmission loss specimen:

A2.3.2.1 At each microphone position in the source room, measure the average sound pressure levels.

A2.3.2.2 At each microphone position in the receiving room, measure the average sound pressure levels and average decay rates.

A2.3.3 Calculate the standard deviation for the mean sound pressure level in each room from the expression:

$$s = \sqrt{\frac{1}{n-1} \sum_{i=1}^n (X_i - \langle X \rangle)^2} \quad (A2.1)$$

where:

- $s$  = standard deviation,
- $X_1$  = individual determination of sound pressure level,
- $\langle X \rangle$  = arithmetic mean of the set of sound pressure levels, and
- $n$  = number of measurements of sound pressure level in the set.

A2.3.4 Calculate the standard deviation of the measurement of  $A_2$  using Eq A2.1 with  $X$  now representing, as appropriate, measurements of mean values of  $A_2$  or decay rate at each microphone position in the receiving room.

NOTE A2.1—These calculations of the standard deviation of  $A_2$  are not strictly accurate. Since  $A_2$  only appears in the expression for transmission loss as the term  $10 \log A_2$ , however, the error in calculating uncertainty is negligible.

A2.3.5 Calculate the 95 % confidence interval for the individual quantities from:

$$\Delta X = as \quad (A2.2)$$

where the factor  $a$ , which depends on the number of measurements, is given in Table A2.1 and  $\Delta X$  and  $s$  represent the confidence interval and standard deviation of  $\langle L_1 \rangle$ ,  $\langle L_2 \rangle$ , and  $A_2$  as appropriate.

A2.3.6 Calculate the confidence interval for transmission loss from:

$$(\Delta TL)^2 = (\Delta \langle L_1 \rangle)^2 + (\Delta \langle L_2 \rangle)^2 + 18.86(\Delta A_2 / \langle A_2 \rangle)^2 \quad (A2.3)$$

**TABLE A2.1 Factors for 95 % Confidence Limits for Averages**

Number of Measurements, $n$	Factor $a$ for Confidence Limits, <sup>A</sup> $X \pm as$
4	1.591
5	1.241
6	1.050
7	0.925
8	0.836
9	0.769
10	0.715
11	0.672
12	0.635
13	0.604
14	0.577
15	0.554
16	0.533
17	0.514
18	0.497
19	0.482
20	0.468
21	0.455
22	0.443
23	0.432
24	0.422
25	0.413
$n > 25$	$a = n^{0.5} / (0.512n - 0.71)$

<sup>A</sup> Limits that may be expected to include the “true” average,  $X$ , 95 times in 100 in a series of problems, each involving a single sample of observations.



If the absorption of the receiving room has been calculated from the average decay rate  $\langle d \rangle$ ,  $18.86(\Delta d / \langle d \rangle)^2$  may be substituted for the last term of Eq A2.3.

A2.3.7 If the confidence intervals calculated do not meet the criteria in A2.2.1, then the rooms do not qualify for measurements according to this test method. Changes to loudspeaker or diffuser arrangements may make the sound fields more uniform.

A2.3.8 If the confidence intervals calculated meet the criteria in A2.2.1, then the rooms qualify for measurements according to this test method and a microphone system can be selected for routine testing as follows:

A2.3.8.1 *Fixed Microphone Positions*—From the array of microphone positions used to determine the confidence limits above, select a subset of locations that yield the same average result, within experimental error, and still meet the confidence requirements of A2.2.1.

A2.3.8.2 *Moving Microphones*—Using the standard deviations calculated for the sound pressure levels in the source and receiving rooms, find the hypothetical minimum number of fixed microphone positions necessary in each room for an acceptable confidence interval in the lowest frequency band. (This requires repeating the calculations for the transmission loss confidence interval using the values of standard deviation found for the large array of microphones and trying different values of  $n$  and  $a$  from Table A2.1 until the confidence limits are satisfied.) If  $n_{min}$  is the minimum number of microphones required in the room and  $\lambda$  is the wavelength of sound at the

lowest frequency of interest, then the minimum size of traverse for each room is calculated from:

*rotating microphones:*

$$r_{min} = \frac{n_{min}\lambda}{4\pi} \quad (A2.4)$$

where:

$r_{min}$  = minimum radius of the circular path traversed by the microphone.

*linear traverses:*

$$L_{min} = (n_{min} - 1)\lambda/2 \quad (A2.5)$$

where:

$L_{min}$  = minimum length of straight line traverse.

A2.3.9 With the dimensions of the microphone path set to the minimum required value or more, by experiment, find positions in each room for the moving microphones that give the same average value of sound pressure level as the extended array within experimental error. This is done in the source room using the normal loudspeaker system as the source of sound. In the receiving room, use the sound coming through the test specimen as the source.

A2.4 The confidence intervals found by these procedures must be remeasured at least annually or whenever significant changes are made to room geometry, loudspeakers, or diffusers. The data from which the estimates of confidence intervals were made must be kept on record.

## APPENDIXES

### (Nonmandatory Information)

#### X1. LABORATORY ACCREDITATION

##### X1.1 Scope

X1.1.1 This appendix covers procedures for accrediting an acoustical testing laboratory to perform tests in conformance with this test method.

##### X1.2 Referenced Documents

X1.2.1 *ASTM Standards*<sup>2</sup>:

E 548 Guide for General Criteria Used for Evaluating Laboratory Competence

E 717 Guide for Preparation of the Accreditation Annex of Acoustical Test Standards

E 1289 Specification for Reference Specimen for Sound Transmission Loss

##### X1.3 General Requirements

X1.3.1 The accrediting agency shall be allowed to make an inspection of the laboratory facilities.

X1.3.2 The testing agency shall make available to the accrediting authority the information required by the following sections of Guide E 458: Personnel, Facilities and Equipment, Calibration, and Test Methods and Procedures.

##### X1.4 Requirements Specific to This Test Method

X1.4.1 *Physical Facilities*—The testing agency shall provide information demonstrating that the following comply with the provisions of this test method:

X1.4.1.1 *Room Size and Shape (see 6.1)*—Provide a sketch showing room dimensions and calculated volumes. Describe any methods used to increase diffusion in the rooms. Show the position of the test specimen on the sketch.

X1.4.1.2 *Room Absorption (see 6.2)*—Provide the measured decay rates and calculated room absorptions for each room for all relevant frequencies.

X1.4.1.3 *Flanking Transmission (see 6.4.2)*—Provide data showing the measured flanking limit for the laboratory.

X1.4.1.4 *Size and Mounting of Test Specimens (see 7.1)*—Provide a sketch showing the dimensions of normal test specimen openings and describe normal installation practices.

X1.4.1.5 *Test Signal Spectrum (see section 8.1)*—Describe the means of generating the sound signals used.

X1.4.1.6 *Location of Sound Sources (see 8.2)*—Provide a sketch showing the locations of the sound source(s) in the rooms.

X1.4.1.7 *Location of Microphones* (see 9.3.1)—Provide a sketch showing the locations or paths of the microphones in the rooms.

X1.4.1.8 *Measurement Bandwidth* (see 10.1)—Provide data to show that the measurement bandwidth is satisfactory.

X1.4.1.9 *Background Noise* (see 11.3)—Provide one-third octave band data showing typical background noise levels measured in the receiving room and associated measurement system. Measurement of typical background noise levels should be made with the microphone and analyzer gains set at their most sensitive setting possible without causing overload.

X1.4.1.10 *Confidence Intervals* (see Annex A2)—Provide data to show that the room sound fields and the microphone sampling system give confidence intervals that satisfy the requirements in Annex A2.

X1.4.2 *Procedures*—The agency shall furnish a report of a complete test (including raw data) and shall show compliance with the following provisions of this test method:

X1.4.2.1 *Microphone Calibration* (see 9.3),

X1.4.2.2 *Determination of average sound pressure levels* (see 11.1),

X1.4.2.3 *Averaging time* (see 11.2),

X1.4.2.4 *Determination of receiving room absorption* (see 11.4), and

X1.4.2.5 *Averaging procedure* (see 12.1).

## X1.5 Reference Specimens

X1.5.1 To be accredited, laboratories must obtain and test routinely a copy of the reference specimen described in Specification E 1289. Additional reference specimens may also be useful. Significant departures from the mean values given in

Specification E 1289 should be investigated thoroughly. After necessary physical adjustments to the rooms and changes in test procedures, laboratories should be able to demonstrate that their results for the reference specimen are not significantly different from those reported in Specification E 1289. Arithmetic corrections to measured data to obtain closer agreement with the data in Specification E 1289 must not be made.

X1.5.2 The Specification E 1289 reference specimen should be measured whenever test procedures used in the laboratory are changed in a way that is likely to influence test results.

X1.5.3 Laboratories must be able to provide test records in report form for the Specification E 1289 reference specimen and any other reference specimens maintained by the laboratory.

X1.5.4 When a new reference specimen is introduced in a laboratory, a set of test records for that specimen needs to be established quickly for use by accreditors as well as the laboratory staff. Initially, the reference specimen should be tested at intervals of about 6 months until 5 sets of data have been obtained. Thereafter, annual testing will suffice. Laboratories are always free to check reference specimens more frequently, but to provide useful information about laboratory repeatability, the reference specimen should be removed and reinstalled between tests.

X1.5.5 Transmission loss data resulting from repeated tests made on reference specimens shall be analyzed by the control chart method described in Part 3 of ASTM STP 15 D (2). The analysis shall be according to the subsection entitled “Control—No Standard Given.”

## X2. RECOMMENDATIONS FOR NEW CONSTRUCTIONS

X2.1 The following paragraphs are intended as guidance for those designing new facilities to satisfy the requirements of this test method.

X2.2 Room volumes of at least 80 m<sup>3</sup> (2800 ft<sup>3</sup>) are preferred and *strongly recommended* for new construction.

X2.3 It is recommended that the volumes of the source and receiving rooms differ by at least 10 %.

X2.4 For meaningful measurements at frequencies lower than 125 Hz, larger room volumes are considered necessary to ensure acceptably uniform sound fields. For example, for measurements down to 100 Hz, a minimum room volume of 125 m<sup>3</sup> (4400 ft<sup>3</sup>) is recommended. For measurements down to 80 Hz, a minimum room volume of 180 m<sup>3</sup> (6400 ft<sup>3</sup>) is recommended. For new construction, room volumes of at least 200 m<sup>3</sup> (7100 ft<sup>3</sup>) are recommended to allow more reliable measurements at low frequencies.

NOTE X2.1—The minimum preferred room volume of 80 m<sup>3</sup> (2800 ft<sup>3</sup>) is derived by assuming that a minimum of approximately 18 modes in the 125 Hz one-third octave band will ensure a satisfactorily diffuse sound

field in the room. The recommendations for 80 and 100 Hz are obtained by assuming that the same mean modal separation required for measurements at 125 Hz will be adequate for measurements at these lower frequencies.

X2.5 *Room Shapes*—It is recommended that no two dimensions of the pair of rooms be the same or in the ratio of small whole numbers. The ratio of largest to smallest dimension of either room should be less than two. The intent of this recommendation is to avoid having resonances at the same frequency in each room in the low frequency bands.

X2.5.1 Theoretical studies of rectangular rooms (8, 9, 10) suggest that the proportions 1:1.26:1.59 provide a good distribution of modes in the lowest bands. Minor deviations in construction, or the presence of sound diffusing devices, will alter the actual distribution.

X2.6 For new test suites, test specimens should preferably form a whole room surface (wall or floor (11)). Alternatively, the depth from the principal surface of each room to the specimen surface should be small compared to the lateral dimensions of the specimen, about 0.5 m or less.

**REFERENCES**

- (1) Warnock, A. C. C., "Influence of Specimen Frame on Sound Transmission Loss Measurement," *Applied Acoustics*, **15**, No. 4, p. 307, 1982.
- (2) *Manual on Presentation of Data and Control Chart Analysis*, ASTM STP 15D, ASTM, 1976, p. 56.
- (3) *Noise and Vibration Control*, Ed. by L. L. Beranek, McGraw-Hill, 1971, p. 228.
- (4) Lubman, D., "Precision of Reverberant Sound Power Measurements," *Journal of the Acoustical Society of America*, Vol 56, No. 2, 1974, p. 523–33.
- (5) *Noise and Vibration Control*, Ed. by L. L. Beranek, McGraw-Hill, 1971, p. 115.
- (6) Mariner, T., "Critique of the Reverberant Room Method of Measuring Air-Borne Sound Transmission Loss," *Journal of the Acoustical Society of America*, Vol 33, 1961, p. 1131.
- (7) Buckingham, E., "Theory and Interpretation of Experiments on the Transmission of Sound Through Partition Walls," *Scientific Papers*, National Institute of Standards and Technology, Vol 20, s506, 1925, p. 193.
- (8) Sempmeyer, L. W., "Computed Frequency and Angular Distribution of the Normal Modes of Vibration in Rectangular Rooms," *Journal of the Acoustical Society of America*, Vol 37, 1965, pp. 413–423.
- (9) Morse, P. M. and Bolt, R. H., "Sound Waves in Rooms," *Reviews of Modern Physics*, Vol 16, No. 2, April 1944.
- (10) Donato, R. J., "Angular Distributions of Lower Room Modes," *Journal of the Acoustical Society of America*, Vol 41, 1967, pp. 1496–1499.
- (11) Kihlman, T. and Nilsson, A. C., "The Effects of Some Laboratory Designs and Mounting Conditions on Reduction Index Measurements," *Journal of Sound and Vibration*, Vol 24, No. 3, 1972, pp. 349–364.

*ASTM International takes no position respecting the validity of any patent rights asserted in connection with any item mentioned in this standard. Users of this standard are expressly advised that determination of the validity of any such patent rights, and the risk of infringement of such rights, are entirely their own responsibility.*

*This standard is subject to revision at any time by the responsible technical committee and must be reviewed every five years and if not revised, either reapproved or withdrawn. Your comments are invited either for revision of this standard or for additional standards and should be addressed to ASTM International Headquarters. Your comments will receive careful consideration at a meeting of the responsible technical committee, which you may attend. If you feel that your comments have not received a fair hearing you should make your views known to the ASTM Committee on Standards, at the address shown below.*

*This standard is copyrighted by ASTM International, 100 Barr Harbor Drive, PO Box C700, West Conshohocken, PA 19428-2959, United States. Individual reprints (single or multiple copies) of this standard may be obtained by contacting ASTM at the above address or at 610-832-9585 (phone), 610-832-9555 (fax), or service@astm.org (e-mail); or through the ASTM website (www.astm.org).*