



Designation: E 96 – 9500^{ε1}

Standard Test Methods for Water Vapor Transmission of Materials¹

This standard is issued under the fixed designation E 96; the number immediately following the designation indicates the year of original adoption or, in the case of revision, the year of last revision. A number in parentheses indicates the year of last reapproval. A superscript epsilon (ε) indicates an editorial change since the last revision or reapproval.

This standard has been approved for use by agencies of the Department of Defense.

^{ε1} NOTE—~~Table 1 was corrected 2 was editorially and the year date was changed on revised in March 6, 1995; 2002.~~

TABLE 1 Metric Units and Conversion Factors^{A,B}

Multiply	by	To Obtain (for the same test condition)
<i>WVT</i>		
g/h·m ²	1.43	grains/h·ft ²
grains/h·ft ²	0.697	g/h·m ²
<i>Permeance</i>		
g/Pa·s·m ²	1.75 × 10 ⁷	1 Perm (inch-pound)
1 Perm (inch-pound)	5.72 × 10 ⁻⁸	g/Pa·s·m ²
<i>Permeability</i>		
g/Pa·s·m	6.88 × 10 ⁸	1 Perm inch
1 Perm inch	1.45 × 10 ⁻⁹	g/Pa·s·m

^AThese units are used in the construction trade. Other units may be used in other standards.

^BAll conversions of mm Hg to Pa are made at a temperature of 0°C.

1. Scope

1.1 These test methods cover the determination of water vapor transmission (WVT) of materials through which the passage of water vapor may be of importance, such as paper, plastic films, other sheet materials, fiberboards, gypsum and plaster products, wood products, and plastics. The test methods are limited to specimens not over 1¼ in. (32 mm) in thickness except as provided in Section 9. Two basic methods, the Desiccant Method and the Water Method, are provided for the measurement of permeance, and two variations include service conditions with one side wetted and service conditions with low humidity on one side and high humidity on the other. Agreement should not be expected between results obtained by different methods. That method should be selected which more nearly approaches the conditions of use.

1.2 The values stated in inch-pound units are to be regarded as the standard. Metric inch-pound conversion factors for WVT, permeance, and permeability are stated in Table 1. All conversions of mm Hg to Pa are made at a temperature of 0°C.

1.3 *This standard does not purport to address all of the safety problems, if any, associated with its use. It is the responsibility of the user of this standard to establish appropriate safety and health practices and determine the applicability of regulatory limitations prior to use.*

2. Referenced Documents

2.1 ASTM Standards:

C 168 Terminology Relating to Thermal Insulating Materials²

¹ These test methods are under the jurisdiction of ASTM Committee C-16 on Thermal Insulation and are the direct responsibility of Subcommittee C16.33 on Thermal Insulation Finishes and Vapor Transmission.

Current edition approved ~~March 6, 1995; April 10, 2000.~~ Published ~~May 1995; July 2000.~~ Originally published as E 96 – 53 T. Last previous edition E 96 – 94.

D 449 Specification for Asphalt Used in Dampproofing and Waterproofing³

D 2301 Specification for Vinyl Chloride Plastic Pressure-Sensitive Electrical Insulating Tape⁴

E 691 Practice for Conducting an Interlaboratory Study to Determine the Precision of a Test Method⁵

3. Terminology

3.1 Definitions of terms used in this standard will be found in Terminology C 168, from which the following is quoted:

“*water vapor permeability*—the time rate of water vapor transmission through unit area of flat material of unit thickness induced by unit vapor pressure difference between two specific surfaces, under specified temperature and humidity conditions.

3.1.1 *Discussion*—Permeability is a property of a material, but the permeability of a body that performs like a material may be used. Permeability is the arithmetic product of permeance and thickness.

“*water vapor permeance*—the time rate of water vapor transmission through unit area of flat material or construction induced by unit vapor pressure difference between two specific surfaces, under specified temperature and humidity conditions.

3.1.2 *Discussion*—Permeance is a performance evaluation and not a property of a material.

3.2 *water vapor transmission rate*—the steady water vapor flow in unit time through unit area of a body, normal to specific parallel surfaces, under specific conditions of temperature and humidity at each surface.”

4. Summary of Test Methods

4.1 In the Desiccant Method the test specimen is sealed to the open mouth of a test dish containing a desiccant, and the assembly placed in a controlled atmosphere. Periodic weighings determine the rate of water vapor movement through the specimen into the desiccant.

4.2 In the Water Method, the dish contains distilled water, and the weighings determine the rate of vapor movement through the specimen from the water to the controlled atmosphere. The vapor pressure difference is nominally the same in both methods except in the variation, with extremes of humidity on opposite sides.

5. Significance and Use

5.1 The purpose of these tests is to obtain, by means of simple apparatus, reliable values of water vapor transfer through permeable and semipermeable materials, expressed in suitable units. These values are for use in design, manufacture, and marketing. A permeance value obtained under one set of test conditions may not indicate the value under a different set of conditions. For this reason, the test conditions should be selected that most closely approach the conditions of use. While any set of conditions may be used and those conditions reported, standard conditions that have been useful are shown in Appendix X1.

6. Apparatus

6.1 *Test Dish*—The test dish shall be of any noncorroding material, impermeable to water or water vapor. It may be of any shape. Light weight is desirable. A large, shallow dish is preferred, but its size and weight are limited when an analytical balance is chosen to detect small weight changes. The mouth of the dish shall be as large as practical and at least 4.65 in.²(3000 mm²x). The desiccant or water area shall be not less than the mouth area except if a grid is used, as provided in 12.1, its effective area shall not exceed 10 % of the mouth area. An external flange or ledge around the mouth, to which the specimen may be attached, is useful when shrinking or warping occurs. When the specimen area is larger than the mouth area, this overlay upon the ledge is a source of error, particularly for thick specimens. This overlay material should be masked as described in 10.1 so that the mouth area defines the test area. The overlay material results in a positive error, indicating excessive water vapor transmission. The magnitude of the error is a complex function of the thickness, ledge width, mouth area, and possibly the permeability. This error is discussed by Joy and Wilson.⁶ This type of error should be limited to about 10 to 12 %. For a thick specimen the ledge should not exceed ¾ in. (19 mm) for a 10-in. (254-mm) or larger mouth (square or circular) or ⅛ in. (3 mm) for a 5-in. (127-mm) mouth (square or circular). For a 3-in. (76-mm) mouth (square or circular) the ledge should not exceed 0.11 in. (2.8 mm) wide. An allowable ledge may be interpolated for intermediate sizes or calculated according to Joy and Wilson.⁶ A rim around the ledge (Fig. X1.1) may be useful. If a rim is provided, it shall be not more than ¼ in. (6 mm) higher than the specimen as attached. Different depths may be used for the Desiccant Method and Water Method, but a ¾-in. (19-mm) depth (below the mouth) is satisfactory for either method.

6.2 *Test Chamber*—The room or cabinet where the assembled test dishes are to be placed shall have a controlled temperature and relative humidity. The temperature chosen shall be between ~~70~~ 21 and ~~90°F~~ (~~24~~ 32°C (70 and ~~32°C~~); 90°F), and shall be maintained constant within ~~1°F~~ (~~0.6°C~~); ±1°C (± 2°F). A temperature of ~~90°F~~ (~~32°C~~) 32°C (90°F) is recommended (Note 1). The relative humidity shall be maintained at 50 ± 2 %, ~~except where~~ (When extremes of humidities are desired, ~~when the~~

² Annual Book of ASTM Standards, Vol 04.06.

³ Annual Book of ASTM Standards, Vol 04.04.

⁴ Annual Book of ASTM Standards, Vol 10.01.

⁵ Annual Book of ASTM Standards, Vol 14.02.

⁶ Joy, F. A., and Wilson, H. G., “Standardization of the Dish Method for Measuring Water Vapor Transmissions,” National Research Council of Canada, Research Paper 279, January 1966, p. 263.

conditions temperature shall be $100.38 \pm 1^\circ\text{F}$ (38.1°C ($100 \pm 0.6^\circ\text{C}$) and 1.8°F) The relative humidity shall be $90 \pm 2\%$ relative humidity; 2% . Both temperature and relative humidity shall be measured frequently⁷, or preferably recorded continuously. Air shall be continuously circulated throughout the chamber, with a velocity sufficient to maintain uniform conditions at all test locations. The air velocity over the specimen in feet per minute shall be, numerically, not less than ten times the permeance of the specimen expressed in perms, not exceeding a maximum of 600 ft/min (3.05 m/s). However, for designed materials with a permeance of greater than 55 perms the velocity shall be 550 ± 50 ft/min (2.80 ± 25 m/s); between 0.02 and 0.3 m·s⁻¹ (0.066 and 1ft/s). Suitable racks shall be provided on which to place the test dishes within the test chamber.

NOTE 1—Simple temperature control by heating alone is usually made possible at 90°F (32°C), 32°C (90°F). However, it is very desirable to enter the controlled space, and a comfortable temperature is more satisfactory for that arrangement. Temperatures of 73.4°F (23°C), 23°C (73.4°F) and 80°F (26.7°C), 26.7°C (80°F) are in use and are satisfactory for this purpose. With cyclic control, the average test temperature may be obtained from a sensitive thermometer in a mass of dry sand. The temperature of the chamber walls facing a specimen over water should not be cooler than the water to avoid condensation on the test specimen.

6.3 *Balance and Weights*—The balance shall be sensitive to a change smaller than 1 % of the weight change during the period when a steady state is considered to exist. The weights used shall be accurate to 1 % of the weight change during the steady-state period. For example: -perm (5.7×10^{-11} kg·Pa⁻¹·s⁻¹·m⁻²) specimen 10 in. (254 mm) square at 80°F (26.7°C) passes 8.6 grains or 0.56 g/day. In 18 days of steady state, the transfer is 10 g. For this usage, the balance must have a sensitivity of 1 % of 10 g or 0.1 g and the weights must be accurate to 0.1 g. If, however, the balance has a sensitivity of 0.2 g or the weights are no better than 0.2 g, the requirements of this paragraph can be met by continuing the steady state for 36 days. An analytical balance that is much more sensitive will permit more rapid results on specimens below 1 perm (5.7×10^{-11} kg·Pa⁻¹·s⁻¹·m⁻²) when the assembled dish is not excessively heavy. A light wire sling may be substituted for the usual pan to accommodate a larger and heavier load.

7. Materials

7.1 *Desiccant and Water:*

7.1.1 For the Desiccant Method, anhydrous calcium chloride in the form of small lumps that will pass a No. 8 (2.36-mm) sieve, and free of fines that will pass a No. 30 (600- μm) sieve, shall be used (Note 2). It shall be dried at 400°F (200°C) before use.

NOTE 2—If CaCl₂ will react chemically on the specimen, an adsorbing desiccant such as silica gel, activated at 400°F (200°C), may be used; but the moisture gain by this desiccant during the test must be limited to 4 %.

7.1.2 For the Water Method, distilled water shall be used in the test dish.

7.2 *Sealant*—The sealant used for attaching the specimen to the dish, in order to be suitable for this purpose, must be highly resistant to the passage of water vapor (and water). It must not lose weight to, or gain weight from, the atmosphere in an amount, over the required period of time, that would affect the test result by more than 2 %. It must not affect the vapor pressure in a water-filled dish. Molten asphalt or wax is required for permeance tests below 4 perms (2.3×10^{-10} kg·Pa⁻¹·s⁻¹·m⁻²). Sealing methods are discussed in Appendix X2.

8. Sampling

8.1 The material shall be sampled in accordance with standard methods of sampling applicable to the material under test. The sample shall be of uniform thickness. If the material is of nonsymmetrical construction, the two faces shall be designated by distinguishing marks (for example, on a one-side-coated sample, “I” for the coated side and “II” for the uncoated side).

9. Test Specimens

9.1 Test specimens shall be representative of the material tested. When a product is designed for use in only one position, three specimens shall be tested by the same method with the vapor flow in the designated direction. When the sides of a product are indistinguishable, three specimens shall be tested by the same method. When the sides of a product are different and either side may face the vapor source, four specimens shall be tested by the same method, two being tested with the vapor flow in each direction and so reported.

9.2 A slab, produced and used as a laminate (such as a foamed plastic with natural “skins”) may be tested in the thickness of use. Alternatively, it may be sliced into two or more sheets, each being separately tested and so reported as provided in 9.4, provided also, that the “overlay upon the cup ledge” (6.1) of any laminate shall not exceed $\frac{1}{8}$ in. (3 mm).

9.3 When the material as used has a pitted or textured surface, the tested thickness shall be that of use. When it is homogeneous, however, a thinner slice of the slab may be tested as provided in 9.4.

9.4 In either case (9.2 or 9.3), the tested overall thickness, if less than that of use, shall be at least five times the sum of the maximum pit depths in both its faces, and its tested permeance shall be not greater than 5 perms (3.3 metric perms).

9.5 The overall thickness of each specimen shall be measured at the center of each quadrant and the results averaged. Measurement of specimens of 0.125 in. or less in thickness shall be made to the nearest 0.0001 in. Measurement of specimens greater than 0.125 in. in thickness shall be made to the nearest 0.001 in.

⁷ Supporting data have been filed at ASTM Headquarters. Request RR: C-16-1014.

⁷ The minimum acceptable is to perform this measurement each time the sample is weighed.

9.6 When testing any material with a permeance less than 0.05 perms or when testing a low permeance material that may be expected to lose or gain weight throughout the test (because of evaporation or oxidation), it is strongly recommended that an additional specimen, or “dummy,” be tested exactly like the others, except that no desiccant or water is put in the dish. Failure to use this dummy specimen to establish modified dish weights may significantly increase the time required to complete the test. Because time to reach equilibrium of water permeance increases as the square of thickness, thick, particularly hygroscopic, materials may take as long as 60 days to reach equilibrium conditions.

10. Attachment of Specimen to Test Dish

10.1 Attach the specimen to the dish by sealing (and clamping if desired) in such a manner that the dish mouth defines the area of the specimen exposed to the vapor pressure in the dish. If necessary, mask the specimen top surface, exposed to conditioned air so that its exposure duplicates the mouth shape and size and is directly above it. A template is recommended for locating the mask. Thoroughly seal the edges of the specimen to prevent the passage of vapor into, or out of, or around the specimen edges or any portion thereof. The same assurance must apply to any part of the specimen faces outside their defined areas. Suggested methods of attachment are described in Appendix X2.

NOTE 3—In order to minimize the risk of condensation on the interior surface of the sample when it is placed in the chamber, the temperature of the water prior to preparation of the test specimen should be within $\pm 2^{\circ}\text{F}$ ($\pm 1.1^{\circ}\text{C}$) of the test condition.

11. Procedure for Desiccant Method

11.1 Fill the test dish with desiccant within $\frac{1}{4}$ in. (6 mm) of the specimen. Leave enough space so that shaking of the dish, which must be done at each weighing, will mix the desiccant.

11.2 Attach the specimen to the dish (see 10.1) and place it in the controlled chamber, specimen up, weighing it at once. (This weight may be helpful to an understanding of the initial moisture in the specimen.)

11.3 Weigh the dish assembly periodically, often enough to provide eight or ten data points during the test. A data point is the weight at a particular time. The time that the weight is made should be recorded to a precision of approximately 1 % of the time span between successive weighing. Thus, if weighings are made every hour, record the time to the nearest 30 s; if recordings are made every day, a time to the nearest 15 min would be allowed. At first the weight may change rapidly; later a steady state will be reached where the rate of change is substantially constant. Weighings should be accomplished without removal of the test dishes from the controlled atmosphere, but if removal is prescribed necessary, the time the specimens are kept at different conditions, temperature or relative humidity, or both, should be kept to a minimum. When results of water vapor transmission are expected to be less than .05 perm, a dummy specimen is strongly recommended. Such a dummy specimen should be attached to an empty cup in the normal manner. The environmental effects of temperature variation and buoyancy variability due to barometric pressure fluctuation can be arithmetically tared out of the weighing values. This precaution permits earlier and more reliable achievement of equilibrium conditions. Analyze the results as prescribed in 13.1.

11.4 Terminate the test or change the desiccant before the water added to the desiccant exceeds 10 % of its starting weight (Note 1 and Note 3). This limit cannot be exactly determined and judgement is required. The desiccant gain may be more or less than the dish weight-gain when the moisture content of the specimen has changed.

NOTE 4—The WVT of some materials (especially wood) may depend on the ambient relative humidity immediately before the test. An apparent hysteresis results in higher WVT if the prior relative humidity was above the test condition and vice versa. It is therefore recommended that specimens of wood and paper products be conditioned to constant weight in a 50 % relative humidity atmosphere before they are tested. Some specimens may be advantageously preconditioned to minimize the moisture that the specimen will give up to the desiccant. This applies when the specimen is likely to have high moisture content or when it is coated on the top (vapor source) side.

12. Procedure for Water Method

12.1 Fill the test dish with distilled water to a level $\frac{3}{4} \pm \frac{1}{4}$ in. (19 ± 6 mm) from the specimen. The air space thus allowed has a small vapor resistance, but it is necessary in order to reduce the risk of water touching the specimen when the dish is handled. Such contact invalidates a test on some materials such as paper, wood, or other hygroscopic materials. The water depth shall be not less than $\frac{1}{8}$ in. (3 mm) to ensure coverage of the dish bottom throughout the test. However, if the dish is of glass, its bottom must be visibly covered at all times but no specific depth is required. Water surges may be reduced in placing a grid of light noncorroding material in the dish to break the water surface. This grid shall be at least $\frac{1}{4}$ in. (6 mm) below the specimen, and it shall not reduce the water surface by more than 10 % (Note 4).

NOTE 5—For the Water Method, baking the empty dish and promptly coating its mouth with sealant before assembly is recommended. The water may be added most conveniently after the specimen is attached, through a small sealable hole in the dish above the water line.

12.2 Attach the specimen to the dish (see 10.1). Some specimens are likely to warp and break the seal during the test. The risk is reduced by preconditioning the specimen, and by clamping it to the dish ledge (if one is provided).

12.3 Weigh the dish assembly and place it in the controlled chamber on a true horizontal surface. Follow the procedure given in 11.3. If the test specimen cannot tolerate condensation on the surface, the dish assembly shall not be exposed to a temperature that differs by more than 5°F (2.8°C) from the control atmosphere to minimize the risk of condensation on the specimen. When results of water vapor transmission are expected to be less than .05 perm, a dummy specimen is strongly recommended. Such a

dummy specimen should be attached to an empty cup in the normal manner. The environment effects of temperature variation and buoyancy variability due to barometric pressure fluctuation can be arithmetically tared out of the weighing values. This precaution permits earlier and more reliable achievement of equilibrium conditions. Analyze the results as prescribed in 13.1.

12.4 Where water is expected to be in contact with the barrier in service, proceed as in 11.3 except place the dish in an inverted position. The dish must be sufficiently level so that water covers the inner surface of the specimen despite any distortion of the specimen due to the weight of the water. With highly permeable specimens it is especially important to locate the test dish so that air circulates over the exposed surface at the specified velocity. The test dishes may be placed on the balance in the upright position for weighing, but the period during which the wetted surface of the specimen is not covered with water must be kept to a minimum.

13. Calculation and Analysis of Results

13.1 The results of the rate of water vapor transmission may be determined either graphically or numerically.

13.1.1 *Dummy Specimen*—If a dummy specimen has been used to compensate for variability in test conditions, due to temperature or barometric pressure, or both, the daily recorded weights can be adjusted by calculating the weight change from initial to time of weighing. This adjustment is made by reversing the direction of the dummy's weight change, relative to its initial weight, and modifying all the appropriate specimen weight(s) recorded at this time. This permits earlier achievement of equilibrium conditions. An alternate procedure, particularly for tests of long duration and more than six weighings, is to subtract the arithmetic mean slope of the rate of weight change of the dummy specimen from the arithmetic mean slope of each similar specimen to get an effective rate of weight change. These procedures are also desirable if the specimen is changing weight due to a curing process while under test.

13.1.2 *Graphic Analysis*—Plot the weight, modified by the dummy specimen when used, against elapsed time, and inscribe a curve which tends to become straight. Judgment here is required and numerous points are helpful. When a straight line adequately fits the plot of at least six properly spaced points (periodic weight changes matching, or exceeding 20 % of the multiple of 100 times the scale sensitivity), a nominally steady state is assumed, and the slope of the straight line is the rate of water vapor transmission.

13.1.3 *Numerical Analysis*—A mathematical least squares regression analysis of the weight, modified by the dummy specimen when used, as a function of time will give the rate of water vapor transmission. An uncertainty, or standard deviation of this rate, can also be calculated to define the confidence band. For very low permeability materials, this method can be used to determine the results after 30 to 60 days when using an analytical balance, with a sensitivity of ± 1 mg, even if the weight change does not meet the 100 times the sensitivity requirement of 6.3. Specimens analyzed in this manner must be clearly identified in the report.

13.2 Calculate the water vapor transmission, WVT, and permeance as follows:

13.2.1 *Water Vapor Transmission:*

$$WVT = G/tA = (G/t)/A \quad (1)$$

where:

In inch-pound units:

G = weight change, grains (from the straight line),
 t = time during which G occurred, h,
 G/t = slope of the straight line, grains/h,
 A = test area (cup mouth area), ft^2 , and
 WVT = rate of water vapor transmission, grains/h· ft^2 .

In metric units:

G = weight change (from the straight line), g,
 t = time, h,
 G/t = slope of the straight line, g/h,
 A = test area (cup mouth area), m^2 , and
 WVT = rate of water vapor transmission, g/h· m^2 .

13.2.2 *Permeance:*

$$\text{Permeance} = WVT/\Delta p = WVT/S(R_1 - R_2) \quad (2)$$

where:

In inch-pound units:

Δp = vapor pressure difference, in. Hg,
 S = saturation vapor pressure at test temperature, in. Hg,
 R_1 = relative humidity at the source expressed as a fraction (the test chamber for desiccant method; in the dish for water method), and
 R_2 = relative humidity at the vapor sink expressed as a fraction

In metric units:

Δp = vapor pressure difference, mm Hg (1.333×10^2 Pa),

- S = saturation vapor pressure at test temperature, mm Hg (1.333×10^2 Pa),
 R_1 = relative humidity at the source expressed as a fraction (the test chamber for desiccant method; in the dish for water method), and
 R_2 = relative humidity at the vapor sink expressed as a fraction.

13.2.3 In the controlled chamber the relative humidity and temperature are the average values actually measured during the test and (unless continuously recorded) these measurements shall be made as frequently as the weight measurements. In the dish the relative humidity is nominally 0 % for the desiccant and 100 % for the water. These values are usually within 3 % relative humidity of the actual relative humidity for specimens below 4 perms (2.3×10^{-7} g·Pa⁻¹·s⁻¹·m⁻²) when the required conditions are maintained (no more than 10 % moisture in CaCl₂ and no more than 1 in. (25 mm) air space above water).

13.3 Only when the test specimen is homogeneous (not laminated) and not less than ½ in. (12.5 mm) thick, calculate its average permeability (perm in.) (metric perm-cm) as follows:

$$\text{Average permeability} = \text{permeance} \times \text{thickness} \quad (3)$$

NOTE 6—*Example:* In a desiccant test that ran 288 h (12 days) on an exposed area of 100 in.² (0.0645 m²), it was found that the rate of gain was substantially constant after 48 h and during the subsequent 240 h, the weight gain was 12 g. The controlled chamber conditions were measured at 89.0°F (31.7°C) and 49 % relative humidity.

Required: WVT and permeance

Calculation (inch-pound units):

$$\begin{aligned}
 G/t &= 12 \text{ g} \times 15.43 \text{ grains/g} \div 240 \text{ h} \\
 &= 0.771 \text{ grains/h}, \\
 A &= 100 \text{ in.}^2 \times 1 \text{ ft}^2/144 \text{ in.}^2 = 0.695 \text{ ft}^2, \\
 S &= 1.378 \text{ in. Hg (from standard references tables),} \\
 R_1 &= 49 \% \text{ (in chamber),} \\
 R_2 &= 0 \% \text{ (vapor sink), and} \\
 \text{WVT} &= 0.771 \text{ grains/h} \div 0.694 \text{ ft}^2 = 1.11 \text{ grains/ft}^2\cdot\text{h}. \\
 \text{Permeance} &= \text{WVT}/\Delta P = \text{WVT}/S (R_1 - R_2) \\
 &= 1.11 \text{ grains/ft}^2\cdot\text{h} \div 1.378 \text{ in. Hg (0.49 - 0)} \\
 &= 1.64 \text{ grains/ft}^2\cdot\text{h}\cdot\text{in. Hg} = 1.64 \text{ perms}
 \end{aligned}$$

Calculation (metric units):

$$\begin{aligned}
 G/t &= 12 \text{ g}/240 \text{ h} = 0.05 \text{ g/h}, \\
 A &= 0.0645 \text{ m}^2, \\
 S &= 35 \text{ mm Hg (from reference tables),} \\
 &= 35 \text{ mm Hg} \times 1.333 \times 10^2 \text{ Pa/mm Hg} = 46.66 \times 10^2 \text{ Pa}, \\
 R_1 &= 49 \% \text{ (in chamber),} \\
 R_2 &= 0 \% \text{ (vapor sink), and} \\
 \text{WVT} &= 0.05 \text{ g/h} \div 0.0645 \text{ m}^2 = 0.775 \text{ g/h}\cdot\text{m}^2. \\
 \text{Permeance} &= \text{WVT}/\Delta P = \text{WVT}/S (R_1 - R_2) \\
 &= 0.775 \text{ g/h}\cdot\text{m}^2 \times 1 \text{ h}/3600 \text{ s} \div 46.66 \times 10^2 \text{ Pa} \times (0.49 - 0) \\
 &= 9.42 \times 10^{-8} \text{ g/Pa}\cdot\text{s}\cdot\text{m}^2
 \end{aligned}$$

13.4 Metric units and conversion factor are given in Table 1.

14. Report

14.1 The report shall include the following:

- 14.1.1 Identification of the material tested, including its thickness.
- 14.1.2 Test method used (desiccant or water).
- 14.1.3 Test temperature.
- 14.1.4 Relative humidity in the test chamber.
- 14.1.5 Permeance of each specimen in perms (to two significant figures).
- 14.1.6 The side of each specimen on which the higher vapor pressure was applied. (The sides shall be distinguished as “side A” and “side B” when there is no obvious difference between them. When there is an obvious difference, this difference shall also be stated, such as “side A waxed” and “side B unwaxed.”).
- 14.1.7 The average permeance of all specimens tested in each position.
- 14.1.8 The permeability of each specimen (as limited by 13.3), and the average permeability of all specimens tested.
- 14.1.9 Include a portion of the plot indicating the section of the curve used to calculate permeability.
- 14.1.10 State design of cup and type or composition of sealant.

15. Precision and Bias ⁸

15.1 *Precision*—Table 2 is based on an interlaboratory tests conducted in 1988 and 1991.^{8,9} In 1988 four materials (A, B, C, D) were tested using the desiccant method and the water method in triplicate. Fifteen laboratories contributed data, with full results secured from four laboratories. In 1991 ten laboratories contributed data for material E, using triplicate specimens, again using both the desiccant method and the water method.

15.1.1 Test results were analyzed using Practice E 691.

15.2 *Bias*—This test method has no bias because water vapor transmission of materials is defined in terms of this test method.

16. Keywords

16.1 permeability; plastics (general); plastic sheet and film; sheet material; thermal-insulating materials; thermal insulation permeability films; water vapor transmission (WVT)

⁸ Available from E. I. DuPont de Nemours & Co., Inc., Polymer Products Dept., Wilmington, DE 19898.

⁸ Supporting data have been filed at ASTM Headquarters. Request RR: C-16-1014.

⁹ Grade Nos. 2305 or 2310 of the Mobil Oil Corp., or their equivalent, have been found satisfactory for this purpose.

⁹ Available from E. I. DuPont de Nemours & Co., Inc., Polymer Products Dept., Wilmington, DE 19898.

APPENDIX

(Nonmandatory Information)

X1. STANDARD TEST CONDITIONS

X1.1 Standard test conditons that have been useful are:

X1.1.1 *Procedure A*—Desiccant Method at 73.4°F (23°C).

X1.1.2 *Procedure B*—Water Method at 73.4°F (23°C).

X1.1.3 *Procedure BW*—Inverted Water Method at 73.4°F (23°C).

X1.1.4 *Procedure C*—Desiccant Method at 90°F (32.2°C).

X1.1.5 *Procedure D*—Water Method at 90°F (32.2°C).

X1.1.6 *Procedure E*—Desiccant Method at 100°F (37.8°C).

TABLE 2 Precision Results from Interlaboratory Testing

For Desiccant Method at 73.4°F:									
Material	Thickness, in.	WVTP (mean), perm	Repeatability ^A			Reproducibility ^A			
			S	CV %	LSD	S	CV %	LSD	
A	0.001	0.606	0.0166	2.70	0.047	0.098	15.0	0.278	
B	0.0055	0.0129	0.0028	22.1	0.008	0.0055	42.6	0.016	
C	0.5	0.0613	0.0044	7.22	0.012	0.0185	30.6	0.052	
D	1.0	0.783	0.0259	3.30	0.073	0.0613	7.8	0.174	
E	0.014	0.0461	0.0023	4.99	0.007	0.0054	11.7	0.015	

For Water Method at 73.4°F:									
Material	Thickness, in.	WVT (mean), perm	Repeatability ^A			Reproducibility ^A			
			S	CV %	LSD	S	CV %	LSD	
A	0.001	0.715	0.0134	1.95	0.039	0.156	21.9	0.44	
B	0.0055	0.0157	0.0022	13.8	0.0062	0.0021	19.4	0.006	
C	0.5	0.097	0.0055	5.7	0.016	0.0195	20.9	0.055	
D	1.0	1.04	0.0192	1.8	0.054	0.217	20.9	0.62	
E	0.014	0.0594	0.0034	5.7	0.010	0.0082	13.8	0.023	

^AFor this data,

S = standard deviation,

CV = percent coefficient of variation ($S \times 100/\text{mean}$), and

LSD = least significant difference between two individual test results based on a 95 % confidence level = $2 \sqrt{2S}$.

^BMaterial B was Teflon⁹ PTFE fluorocarbon resin brand of tetrafluoroethylene. It was extremely difficult to provide a seal to this sample, which accounts for the poor repeatability.

X2. CUP DESIGN AND SEALING METHODS

X1.2 An ideal sealing material has the following properties:

X1.2.1 Impermeability to water in either vapor or liquid form.

X1.2.2 No gain or loss of weight from or to the test chamber (evaporation, oxidation, hygroscopicity, and water solubility being undesirable).

X1.2.3 Good adhesion to any specimen and to the dish (even when wet).

X1.2.4 Complete conformity to a rough surface.

X1.2.5 Compatibility with the specimen and no excessive penetration into it.

X1.2.6 Strength or pliability (or both).

X1.2.7 Easy handleability (including desirable viscosity and thermal of molten sealant).

X1.2.8 Satisfactory sealants possess these properties in varying degrees and the choice is a compromise, with more tolerance in items at the beginning of this list for the sake of those at the latter part of the list when the requirements of 7.2 are met (Note A2). Molten asphalt or wax is required for permeance tests below 4 perms (2.6 metric perms). Tests to determine sealant behavior should include:

X1.2.8.1 An impervious specimen (metal) normally sealed to the dish and so tested, and

X1.2.8.2 The seal normally assembled to an empty dish with no specimen and so tested.

X1.3 The following materials are recommended for general use when the test specimen will not be affected by the temperature of the sealant:

X1.3.1 Asphalt, 180 to 200°F (82 to 93°C) softening point, meeting the requirements of Specification D 449, Type C. Apply by pouring.

X1.3.2 Beeswax and rosin (equal weights). A temperature of 275°F (135°C) is desirable for brush application. Pour at lower temperature.

X1.3.3 Microcrystalline wax¹⁰ (60 %), mixed with refined crystalline paraffin wax (40 %).

X1.4 The materials listed in X1.4.1 are recommended for particular uses such as those shown in Fig. X1.1. The suggested procedure described in X1.4.2 applies to an 11-³/₈-in. (289-mm) square specimen if its permeance exceeds 4 perms (2.6 metric perms) (limited by evaporation of sealants).

X1.4.1 *Materials:*

X1.4.1.1 Aluminum foil, 0.005 in. (0.125 mm) minimum thickness.

X1.4.1.2 Tape, meeting the requirements of Specification D 2301, vinyl chloride plastic pressure-sensitive, electrical insulating tape.

¹⁰ Grade Nos. 2305 or 2310 of the Mobil Oil Corp., or their equivalent, have been found satisfactory for this purpose.

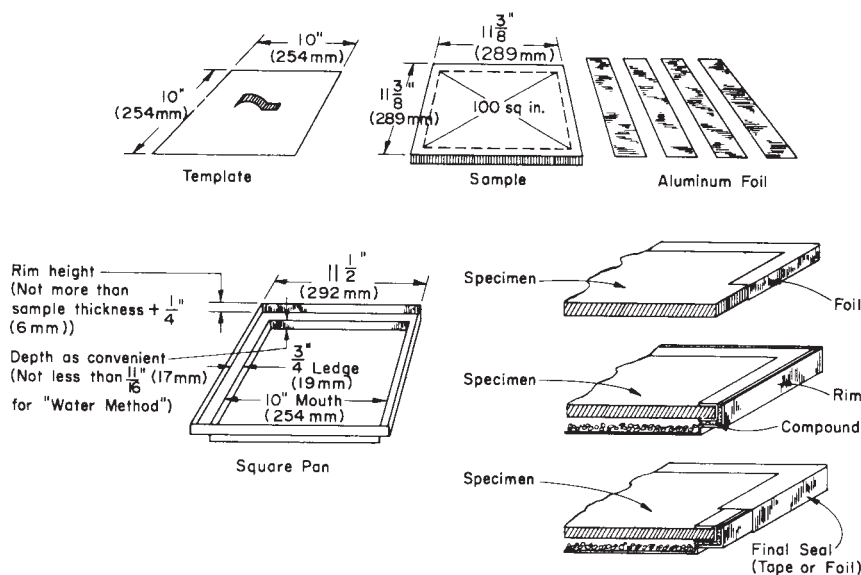

FIG. X1.1 Apparatus for Water Vapor Transmission Tests of Large Thick Specimens

X1.4.1.3 Cement, contact bond, preferably rubber base.

X1.4.2 Procedure:

X1.4.2.1 Step 1—Seal aluminum foil around edges of specimen, leaving a 100-in.²(0.0654-m²) exposed test area on each side. Use contact bond cement as directed by the manufacturer.

X1.4.2.2 Step 2—Spread sealant on inside of rim and ledge. Place desiccant (dry), or water and surge control material (wet) in pan. Press specimen in place. Avoid squeezing compound into the test area.

X1.4.2.3 Step 3—Coat outside of rim and bottom of ledge with contact bond cement, and place foil strips from edge of template, around rim, and bottom of ledge.

X1.5 A method of using hot asphalt, as applied to a 10-in. (254-mm) square-mouth dish with ledge and rim, is as follows:

X1.5.1 Apparatus:

X1.5.1.1 Template—A square frame of brass or steel, $\frac{3}{16}$ in. (5 mm) thick and $\frac{3}{4}$ in. (19 mm) deep. The $\frac{3}{16}$ -in. (5-mm) thickness is tapered to zero at the bottom of the frame where it will touch the test specimen and maintain a 10-in. (254-mm) square test area.

X1.5.1.2 Sealant—Asphalt (see X1.3.1 used at the proper pouring consistency of 375 to 450°F (179 to 232°C).

X1.5.1.3 Melting Pot for the asphalt, electrically heated, with one dimension greater than 11 $\frac{3}{8}$ in. (289 mm).

X1.5.1.4 Small Ladle for pouring.

X1.5.2 Procedure—Mark the 11 $\frac{3}{8}$ -in. (289-mm) square specimen with a line at an equal distance from each edge, so that the area enclosed by the lines is as nearly as possible a 10-in. (254-mm) square. The template may be used for marking. Dip each edge of the specimen in molten asphalt up to the line, so that the test area is defined and all edges are coated with a heavy layer of asphalt. Place the specimen over the pan containing water or desiccant. Lightly oil the template or coat with petroleum jelly on its outer side, and place on the specimen. Pour molten asphalt into the space between the template and the rim of the pan. After the asphalt has cooled for a few minutes, the template should be easily removable.

X1.6 Hot wax may be applied like asphalt. It may also be applied (freely) with a small brush. Its lower working temperature may be advantageous when a specimen contains moisture.

X1.7 Several designs for dishes with supporting rings and flanges are shown in Fig. X1.2. Various modifications of these designs may be made provided that the principle of prevention of edge leakage by means of a complete seal is retained. The dishes may be constructed of any rigid, impermeable, corrosion-resistant material, provided that they can be accommodated on the available analytical balance. A lightweight metal, such as aluminum or one of its alloys, is generally used for larger-size dishes. In some cases when an aluminum dish is employed and moisture is allowed to condense on its surface, there may be appreciable oxidation of the aluminum with a resulting gain in weight. Any gain in weight will ordinarily depend on the previous history of the dish and the cleanness of the surface. An empty dish carried through the test procedure as a control will help to determine whether any error may be expected from this cause. When aluminum dishes are used for the water methods, a pressure may develop inside the assembly during a test due to corrosion. This can cause seal failure or otherwise affect the result. Where this is a problem, it can be overcome by providing inside the dish a protective coating of baked-on epoxy resin or similar material. Dishes with flanges or rings that project from the inner walls of the dish are to be avoided, as such projections influence the diffusion of the water vapor. The depth of the dish for the water procedures is such that there is a 0.80 ± 0.20 in. (20 ± 5-mm) distance between the water surface and the under surface of the specimen, with a water depth of about 0.20 in. (5 mm).

X1.7.1 For the desiccant-in-dish procedures, the dishes need not be as deep as those required for the water-in-dish procedures. The desiccant is within $\frac{1}{4}$ in. (6 mm) of the under surface, and a minimum depth of only $\frac{1}{2}$ in. (12 mm) of desiccant is required.

X1.7.2 The dishes shown in Fig. X1.2 require a molten seal.

X1.7.3 A template such as is shown in Fig. X1.3 is usually used for defining the test area and effecting the wax seal. It consists of a circular metal dish $\frac{1}{8}$ in. (3.18 mm) or more in thickness with the edge beveled to an angle of about 45°. The diameter of

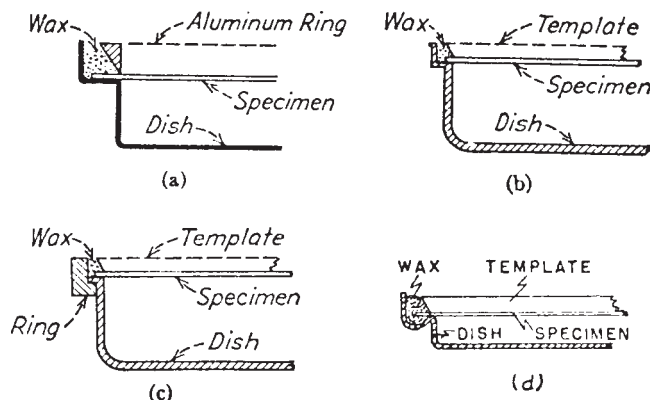

FIG. X1.2 Several Types of Dishes for Water Vapor Transmission Tests of Materials in Sheet Form

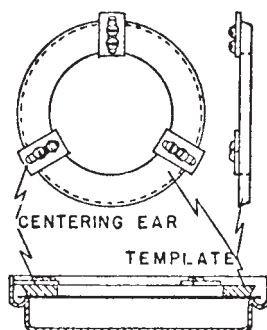

FIG. X1.3 Template Suitable for Use in Making the Wax Seals on Test Dishes

the bottom (smaller) face of the template is approximately equal to, but not greater than, the diameter of the effective opening of the dish in contact with the specimen. Small guides may be attached to the template to center it automatically on the test specimen. A small hole through the template to admit air, and petrolatum applied to the beveled edge of the template facilitate its removal after sealing the test specimen to the dish. In use, the template is placed over the test specimen and when it is carefully centered with the dish opening, molten wax is flowed into the annular space surrounding the beveled edge of the template. As soon as the wax has solidified, the template is removed from the sheet with a twisting motion. The outside flange of the dish should be high enough to extend over the top of the specimen, thus allowing the wax to completely envelop the edge.

X1.7.4 Gasketed types of seals are also in use on appropriately designed dishes. These simplify the mounting of the specimen, but must be used with caution, since the possibility of edge leakage is greater with gasketed seals than with wax seals. Gasketed seals are not permitted for the measurement of permeance less than 44 perms ($2.3 \times 10^{-7} \text{ g} \cdot \text{Pa}^{-1} \cdot \text{s}^{-1} \cdot \text{m}^2$). As a further precaution when gasketed seals are used instead of preferred sealants, a blank test run is suggested using glass or metal as a dummy specimen.

X1.7.5 A suitable weighing cover consists of a circular disk of aluminum $\frac{1}{32}$ to $\frac{3}{32}$ in. (0.8 to 2.4 mm) in thickness provided with a suitable knob in the center for lifting. The cover fits over the test specimen when assembled and makes contact with the inside beveled surface of the wax seal at, or just above, the plane of the specimen. The cover is free of sharp edges which might remove the wax and is numbered or otherwise identified to facilitate its exclusive use with the same dish.

ASTM International takes no position respecting the validity of any patent rights asserted in connection with any item mentioned in this standard. Users of this standard are expressly advised that determination of the validity of any such patent rights, and the risk of infringement of such rights, are entirely their own responsibility.

This standard is subject to revision at any time by the responsible technical committee and must be reviewed every five years and if not revised, either reapproved or withdrawn. Your comments are invited either for revision of this standard or for additional standards and should be addressed to ASTM International Headquarters. Your comments will receive careful consideration at a meeting of the responsible technical committee, which you may attend. If you feel that your comments have not received a fair hearing you should make your views known to the ASTM Committee on Standards, at the address shown below.

This standard is copyrighted by ASTM International, 100 Barr Harbor Drive, PO Box C700, West Conshohocken, PA 19428-2959, United States. Individual reprints (single or multiple copies) of this standard may be obtained by contacting ASTM at the above address or at 610-832-9585 (phone), 610-832-9555 (fax), or service@astm.org (e-mail); or through the ASTM website (www.astm.org).