

This document is not an ASTM standard and is intended only to provide the user of an ASTM standard an indication of what changes have been made to the previous version. Because it may not be technically possible to adequately depict all changes accurately, ASTM recommends that users consult prior editions as appropriate. In all cases only the current version of the standard as published by ASTM is to be considered the official document.



---

**Designation: C 1216 – 92 (Reapproved 1997)**



**Designation: C 1216 – 03**

## Standard Test Method for Adhesion and Cohesion of One-Part Elastomeric Solvent Release Sealants<sup>1</sup>

This standard is issued under the fixed designation C 1216; the number immediately following the designation indicates the year of original adoption or, in the case of revision, the year of last revision. A number in parentheses indicates the year of last reapproval. A superscript epsilon (ε) indicates an editorial change since the last revision or reapproval.

<sup>1</sup> This test method is under the jurisdiction of ASTM Committee C24 on Building Seals and Sealants and is the direct responsibility of Subcommittee C24.20 on General Sealant Standards.

Current edition approved May 10, 2003. Published June 15, 2003. Originally approved in 1992. ~~Published August 1992.~~ Last previous edition approved in 1997 as C 1216 – 92 (1997).

### 1. Scope

1.1 This test method is a laboratory procedure that determines the adhesion and cohesion performance of one-part elastomeric, solvent release sealants at high and low temperatures by the extension and compression of test specimens.

1.2 The values stated in SI units are to be regarded as the standard. The values given in parentheses are for information only.

1.3 The subcommittee with jurisdiction is not aware of any similar ISO standard.

1.4 *This standard does not purport to address all of the safety concerns, if any, associated with its use. It is the responsibility of the user of this standard to establish appropriate safety and health practices and determine the applicability of regulatory limitations prior to use.* For a specific precautionary statement, see Note 2.

### 2. Referenced Documents

2.1 *ASTM Standards:*

C 33 Specification for Concrete Aggregates<sup>2</sup>

C 109 Test Method for Compressive Strength of Hydraulic Cement Mortars (Using 2-in. or 50-mm Cube Specimens)<sup>3</sup>

C 150 Specification for Portland Cement<sup>3</sup>

C 717 Terminology of Building Seals and Sealants<sup>4</sup>

2.2 *Aluminum Association Standard:*

DAF-45 Designation System for Aluminum Finishes<sup>5</sup>

### 3. Terminology

3.1 *Definitions*—Refer to Definitions C 717 for definitions of the following terms used in this test method: adhesive failure, bond breaker, cohesive failure, elastomeric, joint, primer, sealant, solvent release sealant, and substrate.

### 4. Significance and Use

4.1 The failure of a building sealant in a joint that experiences movement is manifested by cohesive failure in the sealant or adhesive failure between the sealant and substrate, or both. This test method evaluates the performance of one-part elastomeric solvent release sealants in joints subjected to movement and temperature aging.

### 5. Apparatus

5.1 *Extension-Compression Machine*, as shown in Fig. 1, designed to extend the test specimens automatically at a constant rate of 3.20 mm (1/8 in.)/h from a joint width of 11.2 mm (7/16 in.) to 14.29 mm (9/16 in.) at  $-12 \pm 2.8^\circ\text{C}$  ( $+10 \pm 5^\circ\text{F}$ ).<sup>6</sup>

5.2 *Oven*, forced-draft type, having the temperature controlled to  $70 \pm 1^\circ\text{C}$  ( $158 \pm 2^\circ\text{F}$ ).

5.3 *Oven*, convection type, having the temperature controlled to  $50 \pm 1^\circ\text{C}$  ( $122 \pm 2^\circ\text{F}$ ).

5.4 *Freezer Chest or Cold Box*, having the temperature controlled to  $-12 \pm 2.8^\circ\text{C}$  ( $+10 \pm 5^\circ\text{F}$ ).

<sup>2</sup> *Annual Book of ASTM Standards*, Vol 04.02.

<sup>3</sup> *Annual Book of ASTM Standards*, Vol 04.01.

<sup>4</sup> *Annual Book of ASTM Standards*, Vol 04.07.

<sup>5</sup> Available from Aluminum Association, 818 Connecticut Ave., 900 19th St. NW, Washington, DC 20006.

<sup>6</sup> Series 520 Sealant Compound Tester, manufactured by Applied Test Systems, Inc., 348 New Castle Rd., Butler, PA 16001, and a durability tester manufactured by Ambard, Inc., 269-11 Sist Ave., New Hyde Park, NY 11040, have been found suitable for this purpose.

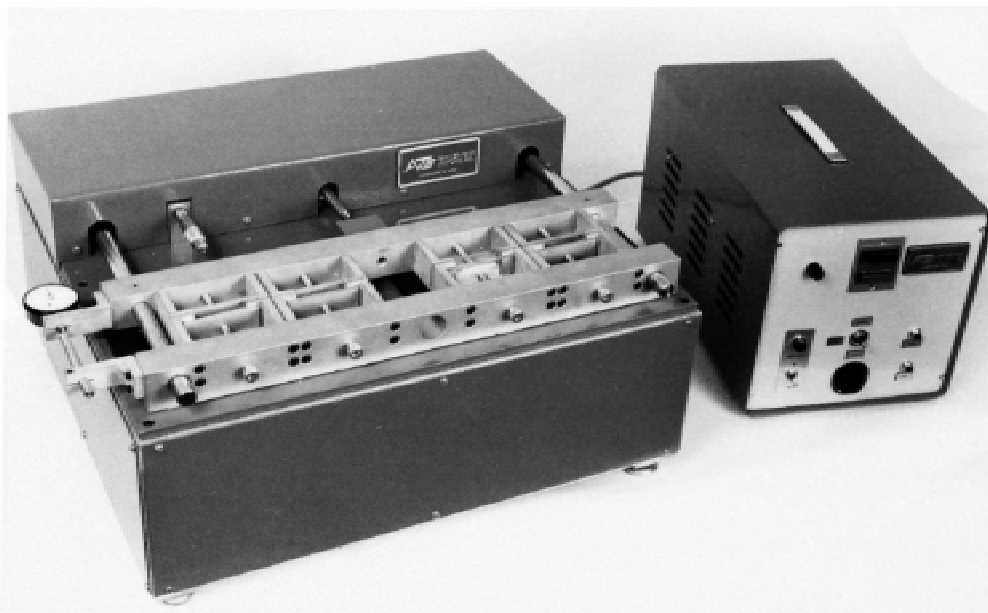

NOTE 1—Three-dimensional view of compression-extension machine with automatic control units shows four specimens ready for compression-extension cycling.

FIG. 1 Compression Extension Machine

5.5 *C-Clamps*, or other clamping devices.

## 6. Reagents

6.1 *Purity of Reagents*—Reagent grade chemicals shall be used in all tests. Unless otherwise indicated, it is intended that all reagents shall conform to the specifications of the Committee on Analytical Reagents of the American Chemical Society, where such specifications are available.<sup>7</sup> Other grades may be used, provided it is first ascertained that the reagent is of sufficiently high purity to permit its use without lessening the accuracy of the determination.

6.2 *Acetone or Methyl Ethyl Ketone Solvents*.

6.3 *Detergent Solution*.<sup>8</sup>

6.4 *Distilled Water*.

6.5 *Primer*, if required.

## 7. Sealants, Substrates, and Accessories

7.1 The sealants shall be obtained from previously unopened containers. Precondition the unopened containers of sealant at  $23 \pm 2^\circ\text{C}$  ( $73.4 \pm 3.6^\circ\text{F}$ ) and  $50 \pm 5\%$  relative humidity for a minimum of 24 h.

7.2 The standard substrates used in the test shall be Portland cement mortar, float glass, and aluminum alloy.

NOTE 1—When requested, other substrates such as brick, marble, etc. may be specified by the purchaser in addition to the standard substrates.

7.2.1 *Mortar blocks*, six, prepared as described in 8.2. The blocks shall be 25.4-mm (1-in.) wide by 76.2-mm (3-in.) long by 25.4-mm (1-in.) thick.

7.2.2 *Glass Plates*, six, of clear float glass 25.4-mm (1-in.) wide by 76.2-mm (3-in.) long by 6.35-mm ( $\frac{1}{4}$ -in.) thick. The float glass may require reinforcement to survive the rigors of the subsequent test procedure. This must be completed prior to the compression-extension cycling described in Section 10. Reinforcement is provided by adhering aluminum plates, 25.4-mm wide by 76.2-mm long by 6.35-mm thick, to the outside surfaces of the glass. Commercially available two-part epoxies are suitable as adhesives. Although the time of reinforcement is not critical, it has been found convenient to apply the aluminum plates to the glass before preparing the test specimens.

7.2.3 *Aluminum Plates*, six, 6063-T5 or 6061-T6 alloy clear, 25.4-mm (1-in.) wide by 76.2-mm (3-in.) long by 6.35-mm ( $\frac{1}{4}$ -in.) thick and anodized to AA-M32C12A31 quality as described by DAF-45.

<sup>7</sup> "Reagent Chemicals, American Chemical Society Specifications," Am. Chemical Soc., Washington, DC. For suggestions on the testing of reagents not listed by the American Chemical Society, see "Reagent Chemicals and Standards," by Joseph Rosin, D. Van Nostrand Co., Inc., New York, NY, and the "United States Pharmacopeia."

<sup>8</sup> Dawn, a registered trademark of Proctor and Gamble, Co., P.O. Box 599, Cincinnati, OH 54201, or Palmolive Green, a registered trademark of Colgate Palmolive Co., 300-T Park Ave., New York, NY 10022, have been found suitable for this purpose.

7.3 *Rigid Spacer Bars*, nine, 12.7 mm (1/2 in.) by 12.7 mm by 50.8 mm (2 in.); 18 bars 12.7 mm by 12.7 mm by 25.4 mm (1 in.); 18 bars 14.29 mm (5/16 in.) by 6.35 mm (1/4 in.) by 25.4 mm (1 in.); and 18 bars 11.1 mm (7/16 in.) by 6.35 mm by 25.4 mm.

7.4 *Release Paper*, or other suitable material, if necessary, to serve as a bond breaker to spacer bars for the preparation of test specimens.

### 8. Preparation of Substrates

8.1 Prior to use, the glass and aluminum (and, when specified, other metallic substrates) shall be cleaned by wiping the surface with methyl ethyl ketone or a similar solvent. Dip the surface in a 0.1 % detergent solution of a clear hand dishwashing detergent in distilled or deionized water. Rinse the surface without touching it in distilled or deionized water and allow it to air dry.

NOTE 2—Methyl ethyl ketone and similar solvents are toxic and flammable and should be handled with caution in a well-ventilated area.

8.2 *Mortar Slabs*—Prepare cement mortar slabs, each 76 by 25.4 by 25.4 mm (3 by 1 by 1 in.) in size, using one part of high early strength Portland cement conforming to Type III of Specification C 150 to two parts by weight of clean, uniformly graded, concrete fine aggregate (sand) conforming to Specification C 33. Use an amount of water sufficient to produce a flow of  $100 \pm 5$  when tested in accordance with the procedure for the determination of consistency of cement mortar described in Test Method C 109. After curing for one day in moist air and six days in saturated lime water at  $23 \pm 2^\circ\text{C}$  ( $73 \pm 3^\circ\text{F}$ ), prepare the surface of 76 by 25.4 by 25.4 mm (3 by 1 by 1 in.) of each slab by wet grinding, either with a belt sander using No. 60 aluminum carbide sanding belt or by using an iron lap with No. 60 silicon carbide (or aluminum oxide) grain, until the aggregate is exposed uniformly. Return the slabs to saturated lime water storage until needed.

8.2.1 The slabs may be prepared and shipped to other locations for use. The slabs may be shipped dry and shall be returned to lime water storage upon arrival until needed.

8.2.2 Prior to use, wet grind the previously ground surface to remove any laitance, rinse thoroughly under running tap water, and dry the slabs overnight at 105 to 110°C (220 to 230°F). To remove any film or powder, clean the slabs by vigorous brushing with a stiff-bristled fiber brush. Condition the slabs at  $23 \pm 2^\circ\text{C}$  ( $73.4 \pm 3.6^\circ\text{F}$ ) for no less than one day and not more than seven days.

8.3 *Primers*—Where the use of a primer is recommended by the sealant manufacturer, the substrate surfaces should be primed.

### 9. Test Specimen Preparation and Conditioning

9.1 Prepare three test specimens (Fig. 2) for each substrate to be tested as follows. If necessary, a bond breaker is placed on the spacer bar surface to eliminate sealant sticking to the surface. Using the spacer bars to control the joint dimensions, form a bead of sealant 12.7-mm (1/2-in.) wide by 12.7-mm thick by 50.8-mm (2-in.) long between the parallel 25.4-mm (1-in.) wide by 76.2-mm (3-in.) long faces of two similar blocks or plates.

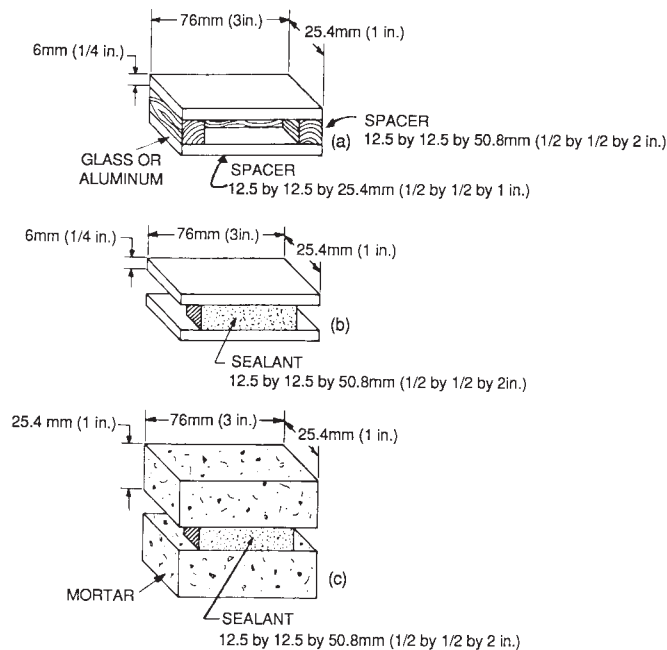

Test Specimens:  
 (a) Prepared specimen before placement of sealant,  
 (b) Sealant with spacers removed,  
 (c) Sealant between mortar blocks.

FIG. 2 Test Specimen

9.2 Condition these specimens according to sealant manufacturer recommendations, but not to exceed a maximum time of 28 days and maximum temperature of  $70 \pm 1^\circ\text{C}$  ( $158^\circ \pm 2^\circ\text{F}$ ).

NOTE 3—Sealant manufacturers should be aware that the conditioning requirements are critical factors that affect the performance of the sealant in this test method.

9.3 Place the specimens in the freezer overnight (16 to 24 h) at  $-12 \pm 2.8^\circ\text{C}$  ( $10 \pm 5^\circ\text{F}$ ). Dislodge spacer bars from sealant at the end of that time, but do not remove the spacer bars from the assembled specimens.

9.4 Remove the specimens from the freezer and condition them for 3 h at  $23 \pm 2^\circ\text{C}$  ( $73.4 \pm 3.6^\circ\text{F}$ ) and  $50 \pm 5\%$  relative humidity.

## 10. Procedure

10.1 Remove the spacer blocks from the specimens.

10.2 Place the specimens in the grips of the extension machine set at 11.1 mm ( $\frac{7}{16}$  in.). Do not alter the specimen dimension. Immediately initiate extension of the joint width to 14.29 mm ( $\frac{9}{16}$  in.) at  $-12 \pm 2.8^\circ\text{C}$  ( $10 \pm 5^\circ\text{F}$ ). When extension is completed, examine, measure, and record any initial adhesive or cohesive loss. Remove the specimens from the machine. Insert appropriate spacers to maintain 14.29-mm ( $\frac{9}{16}$ -in.) joint width. Allow to warm for 3 h at  $23 \pm 2^\circ\text{C}$  ( $73.4 \pm 3.6^\circ\text{F}$ ) and 50 % relative humidity. At this time, examine the specimens, measure, and record adhesive or cohesive failure, or both.

10.3 Remove the spacers from the specimens. Insert 11.1-mm ( $\frac{7}{16}$ -in.) spacers, and compress the specimen with a C-clamp. Place the specimens in a forced-draft oven overnight (16 to 24 h) at  $70 \pm 1^\circ\text{C}$  ( $158 \pm 2^\circ\text{F}$ ). In the event of a weekend at this point in the test cycle, condition the specimens unrestrained at standard conditions.

10.4 Remove the specimens from the oven. Remove the C-clamp and spacers. Condition for a minimum of 3 h at  $23 \pm 2^\circ\text{C}$  ( $73.4 \pm 3.6^\circ\text{F}$ ) and  $50 \pm 5\%$  relative humidity.

10.5 Repeat the steps given in 10.2-10.4 an additional four times.

## 11. Report

11.1 Measure and record any cohesive failure or adhesive failure, or both, in square centimetres (or square inches) for each individual test specimen of mortar, glass, and aluminum. Measure the width and depth of the failure on both substrates of each specimen to determine the total failure area.

11.2 Record the data on a report form (Fig. 3). Record any other observations such as bubble formation, sealant deformation, etc.

11.3 If other than standard substrates are tested, provide a complete description, including priming and preparations, if they deviate from the instructions.

## 12. Precision and Bias

12.1 The precision and bias of this test method has been conducted on concrete only. Although the results may vary according to substrate, other substrates may provide more consistent results due to inconsistencies in concrete.

12.2 The repeatability within a given laboratory interval for three materials tested by five laboratories is  $1.79\text{ cm}^2$  ( $0.278\text{ in.}^2$ ). The difference between the test results obtained in the same laboratory on the same material will be expected to exceed  $1.79\text{ cm}^2$  ( $0.278\text{ in.}^2$ ) approximately 5 % of the time.

12.3 The reproducibility between a given laboratory interval for three materials tested by five laboratories is  $5.64\text{ cm}^2$  ( $0.875\text{ in.}^2$ ). The difference between the test results obtained in a given laboratory on the same material will be expected to exceed  $5.64\text{ cm}^2$  ( $0.875\text{ in.}^2$ ) only approximately 5 % of the time.

## 13. Keywords

13.1 adhesion; cohesion; joint movement; sealant; solvent-release

SUBMITTED BY: \_\_\_\_\_

Test Specimen	CYCLE NO. 1		CYCLE NO. 2		CYCLE NO. 3		CYCLE NO. 4		CYCLE NO. 5		TOTAL	
	Adhesion Loss CM <sup>2</sup>	Cohesion Loss CM <sup>2</sup>	Adhesion Loss CM <sup>2</sup>	Cohesion Loss CM <sup>2</sup>	Adhesion Loss CM <sup>2</sup>	Cohesion Loss CM <sup>2</sup>	Adhesion Loss CM <sup>2</sup>	Cohesion Loss CM <sup>2</sup>	Adhesion Loss CM <sup>2</sup>	Cohesion Loss CM <sup>2</sup>	Adhesion Loss CM <sup>2</sup>	Cohesion Loss CM <sup>2</sup>
Glass												
1												
2												
3												
Aluminum												
1												
2												
3												
Mortar												
1												
2												
3												
Comments												

**FIG. 3 Adhesion and Cohesion; One-Part Solvent Release Elastomeric Sealant**

*ASTM International takes no position respecting the validity of any patent rights asserted in connection with any item mentioned in this standard. Users of this standard are expressly advised that determination of the validity of any such patent rights, and the risk of infringement of such rights, are entirely their own responsibility.*

*This standard is subject to revision at any time by the responsible technical committee and must be reviewed every five years and if not revised, either reapproved or withdrawn. Your comments are invited either for revision of this standard or for additional standards and should be addressed to ASTM International Headquarters. Your comments will receive careful consideration at a meeting of the responsible technical committee, which you may attend. If you feel that your comments have not received a fair hearing you should make your views known to the ASTM Committee on Standards, at the address shown below.*

*This standard is copyrighted by ASTM International, 100 Barr Harbor Drive, PO Box C700, West Conshohocken, PA 19428-2959, United States. Individual reprints (single or multiple copies) of this standard may be obtained by contacting ASTM at the above address or at 610-832-9585 (phone), 610-832-9555 (fax), or service@astm.org (e-mail); or through the ASTM website (www.astm.org).*