



Designation: C 1306 – 9500

Standard Test Method for Hydrostatic Pressure Resistance of a Liquid-Applied Waterproofing Membrane¹

This standard is issued under the fixed designation C 1306; the number immediately following the designation indicates the year of original adoption or, in the case of revision, the year of last revision. A number in parentheses indicates the year of last reapproval. A superscript epsilon (ϵ) indicates an editorial change since the last revision or reapproval.

1. Scope

1.1 This test method describes a laboratory procedure for determining the resistance of a waterproofing membrane to hydrostatic pressure.

1.2 The values stated in SI units are to be regarded as the standard. The inch-pound units given in parentheses are for information only.

1.3 *This standard does not purport to address all of the safety concerns, if any, associated with its use. It is the responsibility of the user of this standard to establish appropriate safety and health practices and determine the applicability of regulatory limitations prior to use.*

1.4 There are no ISO standards similar or equivalent to this ASTM standard.

2. Referenced Documents

2.1 *ASTM Standards:*

C 33 Specification for Concrete Aggregates²

¹ This test method is under the jurisdiction of ASTM Committee C-24 on Building Seals and Sealants and is the direct responsibility of Subcommittee C24.80 on Building Deck Waterproofing Systems.

Current edition approved ~~Sept. 10, 1995~~; June 10, 1995; 2000. Published ~~November 1995~~; August 2000. Originally published as C 1306-95. Last previous edition C 1306-95.

C 150 Specification for Portland Cement³

C 717 Terminology of Building Seals and Sealants⁴

3. Terminology

3.1 *Definitions*—Refer to Terminology C 717 for definitions of technical terms used in this test method. Some of these are *elastomeric*, *substrate*, *waterproofing*, and *compound*.

4. Summary of Test Method

4.1 This test method is conducted in two stages. In the first stage, the test membrane is subjected to hydrostatic pressure that is increased steadily over an 8 h period until the specimen fails or the maximum pressure is achieved. In the second part of the test, three more specimens are subjected to hydrostatic pressure that is increased slowly from 50 % of the failure value to failure in 2.5 psi increments every two to three days.

5. Significance and Use

5.1 This test method is used as a screening tool to determine the hydrostatic pressure to which a liquid-applied waterproofing membrane may be subjected without failing when stretched over a crack in the substrate. This test method discriminates between a membrane that is very resistant to hydrostatic pressure and one that is not. Because of the variability inherent in this test method, it is not recommended that this test method be used to set a numerical standard for hydrostatic pressure resistance. No prediction of durability at lower hydrostatic pressures can be made when using the results of this test method.

6. Comparison to Other Standards

6.1 The committee with jurisdiction over this standard is not aware of any comparable standards published by other organizations.

7. Apparatus and Materials

67.1 *Test Apparatus*, made of Schedule 80 PVC pipe pieces and constructed as shown in Fig. 1.

67.2 *Masking Tape*.

67.3 *TFE-Fluorocarbon or Polyethylene Spacers*, three, 51 by 19 by 3 mm (2 by 0.75 by 0.125 in.).

67.4 *Circulating Hot-Air Oven*.

67.5 *Portland Cement*, high early strength, conforming to Specification C 150, Type III.

67.6 *Fine Aggregate*, conforming to Specification C 33.

67.7 *Source of Regulated Compressed Air*, capable of at least 45 psig.

67.8 *Molds*, eight, 102 by 50 by 13 mm (4 by 2 by 0.5 in.) inside dimensions, for casting mortar blocks.

67.9 *Epoxy Cement*, with gap filling capability, or non-sag construction mastic.

67.10 *Sealing Gaskets*, eight, 102 mm (4 in.) outside diameter by 57 mm (2.25 in.) inside diameter by 6 mm (0.25 in.) thick made of very soft rubber.⁵

67.11 *Vernier Calipers*.

78. Preparation of Substrates

78.1 Mix 1 part by weight of Portland cement with 2 parts by weight of fine aggregate and stir in approximately 0.7 part by weight of water to produce a uniform mixture.

78.2 Pour the mixture into the mold and allow to cure one day at 100 % relative humidity followed by six days in tap water, both at standard temperature.

NOTE 1—Prepare enough mortar to produce four blocks, each measuring 101 by 101 by 12 mm (4 by 4 by 0.5 in.).

78.3 Cut or grind the test surfaces of the mortar blocks to remove laitance and produce a level substrate, free of fins or burrs. If a release coating is used on the mold, use only the top surface of the mortar blocks, not exposed to the release coating, as the test surface. Cut the blocks into matching pairs each measuring approximately 101 by 50 by 12 mm (4 by 2 by 0.5 in.).

78.4 When a quantity of blocks is prepared, store them in saturated lime water until needed.

78.5 Rinse any residue from the substrates with tap water and allow them to dry overnight in an oven at 70°C (158°F) minimum.

78.6 Other substrates may be used, and shall be prepared to provide a clean, level test surface. Other preparation requirements shall be as agreed upon between the supplier and the specifier.

8. Conditioning/Mixing

8.1 Store all materials to be tested at standard conditions of $23 \pm 2^\circ\text{C}$ ($73.4 \pm 3.6^\circ\text{F}$) and $50 \pm 5\%$ relative humidity for at

² Annual Book of ASTM Standards, Vol 04.02.

³ Annual Book of ASTM Standards, Vol 04.01.

⁴ Annual Book of ASTM Standards, Vol 04.07.

⁵ Adco SP 505 and Ashland Plioseal T408 rubber sealing tapes have been found suitable for this purpose.

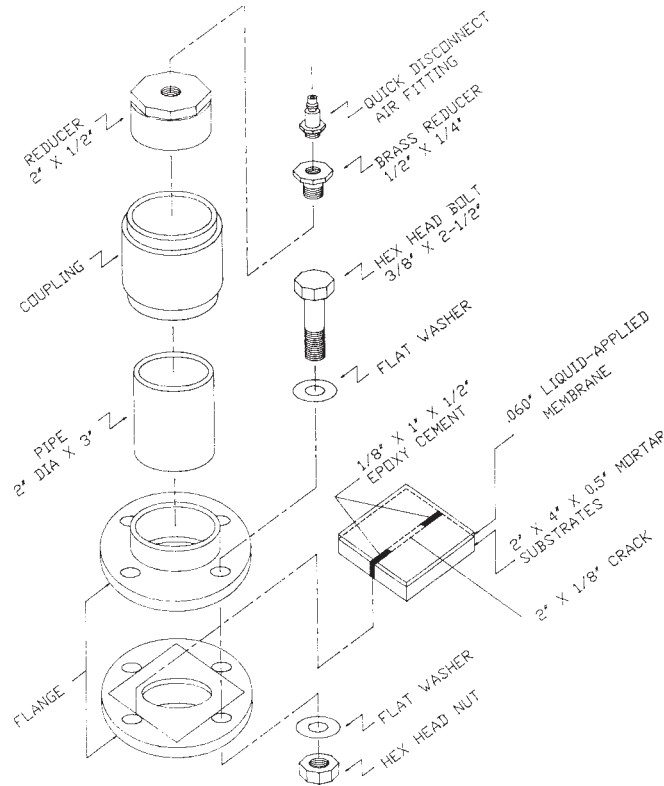

NOTE 1—All parts made of schedule 80 PVC.

FIG. 1 Testing Apparatus

least 24 h before any test specimens are prepared.

8.2 Follow the manufacturer's instructions for mixing and preparing membrane materials for testing.

8.3 When a primer is required by the membrane manufacturer, use the primer as instructed by the membrane manufacturer.

9. Conditioning/Mixing

9.1 Store all materials to be tested at standard conditions of $23 \pm 2^\circ\text{C}$ ($73.4 \pm 3.6^\circ\text{F}$) and $50 \pm 5\%$ relative humidity for at least 24 h before any test specimens are prepared.

9.2 Follow the manufacturer's instructions for mixing and preparing membrane materials for testing.

9.3 When a primer is required by the membrane manufacturer, use the primer as instructed by the membrane manufacturer.

10. Procedure

910.1 *Application of the Membrane to the Test Substrate:*

910.1.1 Prepare four specimens. One will be used for the rapid screening test and the others will be used for the longterm test.

910.1.2 Measure the thickness of each block to the nearest 0.025 mm (0.001 in.), using vernier calipers. Record this value.

910.1.3 For self-leveling membrane materials, lay the bound blocks on a sand bed and level them. Apply 50 mm (1 in.) wide masking tape around the perimeter of the joined test substrates so that approximately half of the width of the tape protrudes above the test surface on all four sides to form a dam. Add sufficient material to yield a dry film thickness of 1.5 ± 0.1 mm (0.060 ± 0.005 in.). Check the coating thickness with a wet film gage. The film thickness may be built up in several coats if specified by the manufacturer.

910.1.4 For non-sag materials, stretch a rubber band around the perimeter of the substrate to keep the joint closed. Apply a film of membrane at a dry film thickness of 1.5 ± 0.1 mm (0.060 ± 0.005 in.). Ensure that the material is a uniform thickness by using a draw-down bar or similar device.

910.1.5 Allow the membrane to cure one week at room temperature and 50 % relative humidity followed by one week in an oven at 70°C (158°F). Remove the test specimens from the oven and allow them to cool to room temperature for at least 1 h. Lay the specimens with membrane surface down on release paper.

910.1.6 Using vernier calipers, carefully measure the thickness of the substrate-membrane composite on either side of the joint. Measure to the nearest 0.025 mm (0.001 in.). Avoid stretching or tearing the membrane while measuring the thickness. Record these measurements.

910.1.7 Remove all masking tape. Insert a TFE-fluorocarbon or polyethylene spacer into the center of the joint of one of the membrane-mortar composites, leaving a cavity 3 by 25 mm (0.125 by 1 in.) at either end of the joint. Make sure the spacer is

touching the membrane but does not cut it. Fill the cavities on either side of the spacer with premixed epoxy cement or construction adhesive (such as Liquid Nails⁶ brand).

910.1.8 The specimen may have to be clamped to keep it flat. Clamp it with “C” clamps or a heavy piece of angle iron. Place the angle iron with one side resting on either side of the joint to form an inverted “V” with the point above the joint.

910.1.9 Allow the cement to cure for one day. Remove the clamps and spacer.

910.2 *Conduct Rapid Test:*

910.2.1 Install one membrane-mortar composite in the test apparatus by placing one sealing gasket on top of the membrane and one sealing gasket under the test specimen. Place the test specimen with membrane side up in the test apparatus and draw down on the bolts to a snug fit.

NOTE 2—Be careful not to use excessive torque which will cause the test specimen to fracture. See Fig. 1.

910.2.2 Fill the test apparatus with approximately 100 mL of tap water. Place the tester inside a container to catch water when failure of the membrane occurs.

910.2.3 Connect the apparatus to a regulated air supply and apply 0.034 MPa (5 psig) of air pressure. Increase the air pressure by approximately 0.017 MPa (2.5 psig) every 15 min until membrane fails or pressure exceeds 0.310 MPa (45 psig). Water leaking from the bottom of the test apparatus indicates failure.

NOTE 3—Verify that the membrane has actually failed (and that the tester has not developed a leak) by adjusting the air pressure to 0.034 MPa (5 psig) or less, inverting the apparatus, and visually examining the membrane at the joint.

910.3 *Conduct the Long-Term Test:*

910.3.1 Repeat the procedures in 910.2.1 and 910.2.2.

910.3.2 Connect the apparatus to a regulated air supply and apply air pressure at 80 % of failure value determined in 910.2. Increase the air pressure by approximately 0.017 MPa (2.5 psig) every two days (or three days over a weekend). Continue the test until the membrane fails or the pressure exceeds 0.310 MPa (45 psig). Water leaking from the bottom of the test apparatus indicates failure.

NOTE 4—Verify that the membrane has actually failed (and that the tester has not developed a leak) by adjusting the air pressure to 0.034 MPa (5 psig) or less, inverting the apparatus, and visually examining the membrane at the joint.

910.3.3 Repeat this test with the two remaining membrane-mortar composites.

101. Calculation

101.1 Calculate the measured dry film thickness as:

$$DFT = BM - B \quad (1)$$

where:

DFT = measured dry film thickness,

BM = thickness of membrane-mortar composite, and

B = thickness of block.

11. Report

11.1 Report the following information:

11.1.1 The measured dry film thickness of the membrane as calculated in 10.1;

11.1.2 The air pressure in megapascals at which the membrane failed or the test was stopped in the rapid test (see Section 2);

11.1.3 The air pressure in megapascals, at which each of the three membranes failed, or the test was stopped, in the long-term test. Also record the average of these three results, and

11.1.4 The duration of each test in hours or days. Also report the average of the three results for the long-term test.

12. Report

12.1 Report the following information:

12.1.1 The measured dry film thickness of the membrane as calculated in 11.1,

12.1.2 The air pressure in megapascals at which the membrane failed or the test was stopped in the rapid test (see Section 2),

12.1.3 The air pressure in megapascals, at which each of the three membranes failed, or the test was stopped, in the long-term test. Also record the average of these three results, and

12.1.4 The duration of each test in hours or days. Also report the average of the three results for the long-term test.

13. Precision and Bias

123.1 *Repeatability*— The repeatability (within a given laboratory) interval for three materials tested by three laboratories is 14.931 psi. In future use of this test method, the difference between two test results obtained in the same laboratory on the same

⁶ Liquid Nails brand, available from Macco, has been found suitable for this purpose.

material will be expected to exceed 14.931 psi only about 5 % of the time.

123.2 Reproducibility— The reproducibility (between given laboratories) interval for three materials tested by three laboratories is 21.082 psi. In future use of this test method, the difference between two test results obtained in different laboratories on the same material will be expected to exceed 21.082 psi only about 5 % of the time.

134. Keywords

134.1 hydrostatic; membrane; waterproofing

ASTM International takes no position respecting the validity of any patent rights asserted in connection with any item mentioned in this standard. Users of this standard are expressly advised that determination of the validity of any such patent rights, and the risk of infringement of such rights, are entirely their own responsibility.

This standard is subject to revision at any time by the responsible technical committee and must be reviewed every five years and if not revised, either reapproved or withdrawn. Your comments are invited either for revision of this standard or for additional standards and should be addressed to ASTM International Headquarters. Your comments will receive careful consideration at a meeting of the responsible technical committee, which you may attend. If you feel that your comments have not received a fair hearing you should make your views known to the ASTM Committee on Standards, at the address shown below.

This standard is copyrighted by ASTM International, 100 Barr Harbor Drive, PO Box C700, West Conshohocken, PA 19428-2959, United States. Individual reprints (single or multiple copies) of this standard may be obtained by contacting ASTM at the above address or at 610-832-9585 (phone), 610-832-9555 (fax), or service@astm.org (e-mail); or through the ASTM website (www.astm.org).