



Standard Test Method for Heat Resistance of Hot-Applied Sealants Under Dead Load Shear¹

This standard is issued under the fixed designation C 1367; the number immediately following the designation indicates the year of original adoption or, in the case of revision, the year of last revision. A number in parentheses indicates the year of last reapproval. A superscript epsilon (ϵ) indicates an editorial change since the last revision or reapproval.

1. Scope

1.1 This test method covers a laboratory procedure for determining the heat resistance of hot-applied sealants, herein referred to as sealant. This test method is conducted under dead load in a shear mode.

1.2 The values stated in SI units are to be regarded as the standard. The values given in parentheses are provided for information purposes only.

1.3 *This standard does not purport to address all of the safety concerns, if any, associated with its use. It is the responsibility of the user of this standard to establish appropriate safety and health practices and determine the applicability of regulatory limitations prior to use.*

2. Referenced Documents

2.1 ASTM Standards:

- B 209 Specification for Aluminum and Aluminum-Alloy Sheet and Plate²
- C 717 Terminology of Building Seals and Sealants³
- C 1036 Specification for Flat Glass⁴

3. Terminology

3.1 *Definitions*—Definitions of the following terms used in this test method are found in Terminology C 717, 4.1: adhesive failure, cohesive failure, hot-applied sealant, sealant, and substrate.

3.2 *Definitions of Terms Specific to This Standard*—Definitions of the following terms used in this test method are found in Terminology C 717, 4.2: applicator and specified temperature.

4. Summary of Test Method

4.1 The hot-applied sealant is placed between glass and aluminum substrates. The specimen is heated in shear mode with a weight suspended from the specimen. The time that it takes for the specimen to fail is recorded.

5. Significance and Use

5.1 Sealants are generally subjected to stresses in end-use applications. This test method measures the heat resistance of sealants when subjected to dead load shear stresses while under heat.

6. Apparatus

6.1 *Applicator⁵ or Oven*, capable of maintaining the sealant within $\pm 2.8^\circ\text{C}$ ($\pm 5^\circ\text{F}$) of the specified temperature.

6.2 Substrates:

6.2.1 Annealed glass that is 25.4 mm wide by 76.2 mm long and 6.35 mm thick (1 in. by 3 in. by 0.25 in.). (See Specification C 1036.)

6.2.2 Aluminum alloy 5052-H32 that is 25.4 mm wide by 76.2 mm long and 0.508 mm thick (1 in. by 3 in. by 0.020 in.). (See Specification B 209.)

6.2.3 Other substrates may be used when specified (Fig. 1).

6.3 *Template*, to provide 3.28-mm ($1/8$ -in.) sealant thickness (Fig. 2).

6.4 Hot Knife.

6.5 *Test Oven*, capable of maintaining 70°C (158°F) within $\pm 2.8^\circ\text{C}$ ($\pm 5^\circ\text{F}$). This oven must contain some apparatus for suspending the specimens in shear mode during testing. Automatic timing devices and recorders may be used to record the time it takes for the test specimens to shear apart.

7. Sampling

7.1 Sealant shall be free of external surface contaminants such as talc, oil, dust, and moisture. Handling of the sealant surfaces in contact with the substrate shall be minimized.

7.2 A 1.0-kg (2.2-lb) representative sample shall be taken from bulk stock for testing.

8. Test Specimens

8.1 Prepare five test specimens from the bulk sample by using the applicator or oven method.

8.1.1 Applicator Method:

8.1.1.1 Clean the glass surface with an approved glass cleaner.

¹ This test method is under the jurisdiction of ASTM Committee C24 on Building Seals and Sealants and is the direct responsibility of Subcommittee C24.20 on General Sealant Standards.

Current edition approved Feb. 10, 1997. Published April 1997.

² *Annual Book of ASTM Standards*, Vol 02.02.

³ *Annual Book of ASTM Standards*, Vol 04.07.

⁴ *Annual Book of ASTM Standards*, Vol 15.02.

⁵ The sole source of supply of the apparatus known to the committee at this time is a Hardman PSA gun, Hardman Inc., Belleville, NJ 07109. If you are aware of alternative suppliers, please provide this information to ASTM Headquarters. Your comments will receive careful consideration at a meeting of the responsible technical committee,¹ which you may attend.

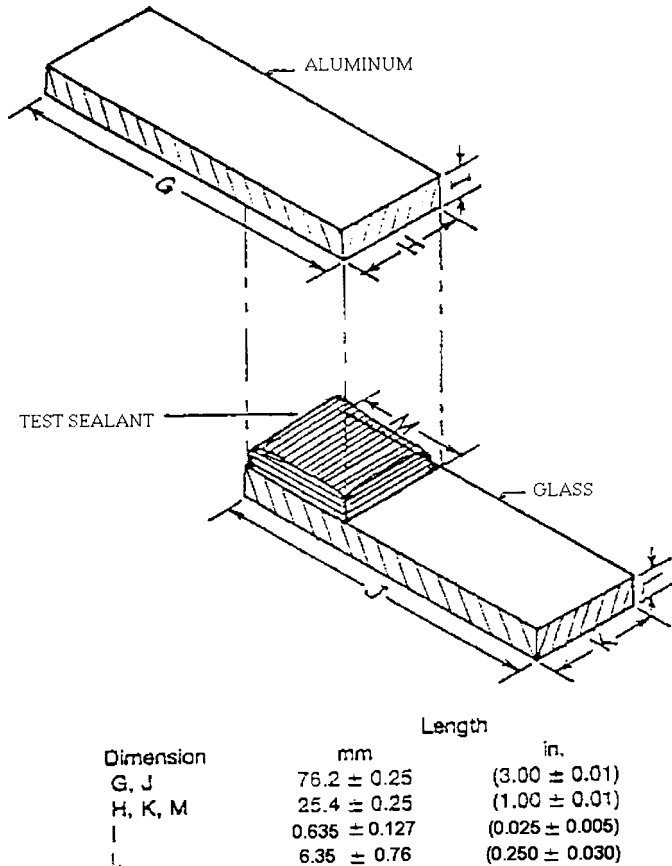
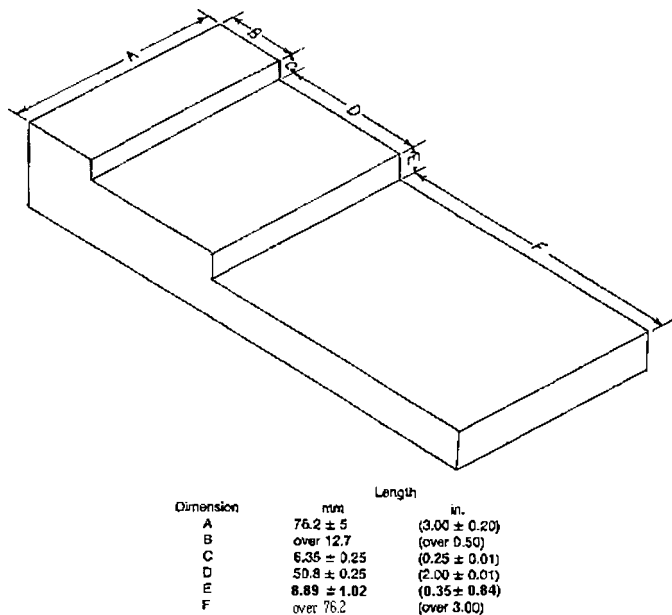

FIG. 1 Assembly of Test Sealant on Substrates



NOTE 1—The template shall be made of a material of low thermal conductivity, such as wood or fiberglass.

FIG. 2 Template

8.1.1.2 Clean the aluminum surface by solvent wiping with toluene and wiping dry.

8.1.1.3 Using the appropriate die, apply a 25.4 by 25.4-mm (1 by 1-in.) layer of sealant onto one end of the glass surface

at a thickness that when compressed will comply with 8.1.1.5. All substrates shall be at a temperature of 23 ± 2°C (73.4 ± 3.6°F). Apply the sealant at the temperature specified by the sealant manufacturer.

NOTE 1—Most sealant manufacturers recommend an application temperature of 190 to 200°C (375 to 400°F).

8.1.1.4 Immediately after sealant application, place the aluminum substrate onto the sealant to form an overlap of 6.45 cm² (1 in.²) (Fig. 1).

8.1.1.5 Using a template (Fig. 2), compress the overlaid sealant to form a 3.18-mm (1/8-in.) thick overlap (Fig. 3).

8.1.1.6 Remove excess sealant from the specimen with a hot knife.

8.1.2 Oven Method:

8.1.2.1 Clean the glass surface with an approved glass cleaner.

8.1.2.2 Place sufficient sealant onto the substrate so that when compressed, a 6.45-cm² (1-in.²) overlap that will comply with 8.1.2.5 is obtained.

8.1.2.3 Clean the aluminum substrate by solvent wiping with toluene and wiping dry.

8.1.2.4 Separately place both the glass with sealant and the overlapping aluminum into an oven and condition for 30 min at the specified temperature.

8.1.2.5 Immediately upon removing the substrates from the oven, place the aluminum substrate onto the sealant over the glass substrate (Fig. 1). Using the template (Fig. 2), compress the overlaid sealant to form a 3.18-mm (1/8-in.) thick overlap (Fig. 3).

8.1.2.6 Remove excess sealant from the specimen with a hot knife.

8.2 When the specimens have cooled, cover the end of the glass substrate with several layers of masking tape. Press the tape firmly onto the glass. Cut small rectangular areas out of the tape so that the glass substrate can be seen.

8.3 When the specimens have cooled, prepare the aluminum end to hold a 500-g (1.10-lb) weight for the duration of the test. This can be done by drilling or punching a hole at the end of the aluminum substrate (centering the hole). This hole is used for suspending the 500-g test weight. Alternatively, the end can be punched to create a raised surface or otherwise modified to allow suspension of the weight.

9. Conditioning

9.1 Condition all test specimens at 23 ± 2°C (73.4 ± 3.6°F) and 50 ± 10 % relative humidity for at least 24 h prior to testing.

9.2 Additional conditioning may be done as specified by mutual agreement between the purchaser and sealant manufacturer.

10. Procedure

10.1 Suspend the glass end of the specimen in the oven set at 70 ± 28°C (158 ± 5°F). Clips can be attached to the glass (over the cut out rectangle) and suspended from the top of the oven. Clamps may also be used or any device that allows the specimens to hang vertically during the test.

10.2 Attach a 500-g (1.10-lb) weight to the aluminum end of the specimen. Some weights have hooks permanently attached.

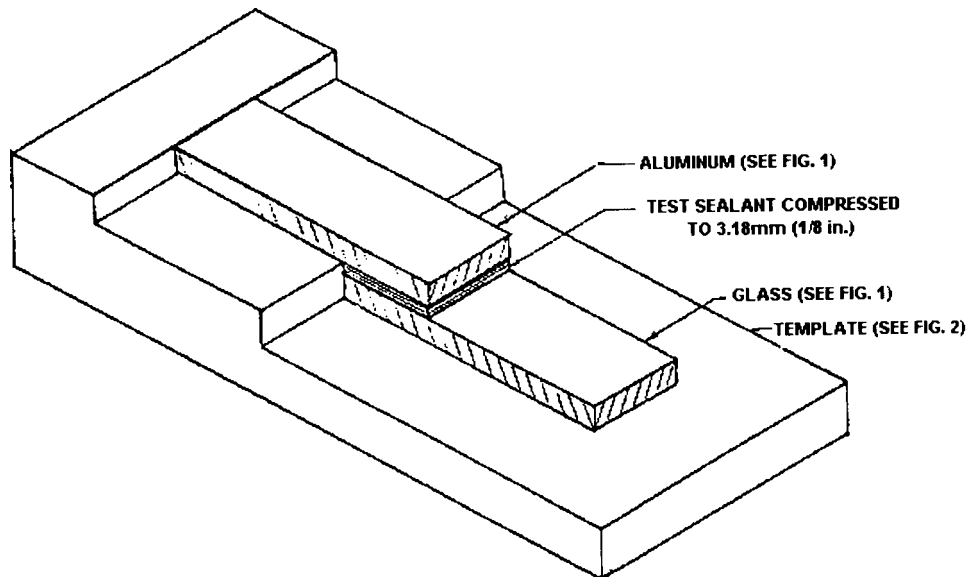

FIG. 3 Test Assembly on Template After Compression

Alternatively, any device that allows the weight to hang vertically during the test may be used.

10.3 Close the oven door and maintain 70°C (158°F) for the duration of the test.

10.4 Record the time in minutes to shear failure of the specimens.

10.5 Examine the shears and record the type of failure, adhesive or cohesive, and percentage of each.

NOTE 2—The oven must be at 70°C before suspending specimens. The specimens should be suspended as quickly as possible to avoid excessive heat loss. The oven should be monitored to ensure that 70°C is maintained for the duration of this test method.

11. Report

11.1 Report the following information:

11.1.1 Sealant name and any other identifying characteristics,

11.1.2 Equipment used to apply the sealant,

11.1.3 Average time to failure in minutes,

11.1.4 Type of failure, adhesive or cohesive, and percentage of each,

11.1.5 Any substrate deformation during testing and the degree of deformation,

11.1.6 Sealant application temperature,

11.1.7 Oven temperature and time of conditioning,

11.1.8 Substrates tested,

11.1.9 Substrate cleaning procedure, and

11.1.10 Any additional conditioning as allowed by 9.2.

12. Precision and Bias

12.1 The precision and bias of this test method are based on data obtained from four laboratories using aluminum and glass substrates and three sealants. Both applicator and oven methods were used and the mode of failure on all samples was cohesive.

12.2 The repeatability (within a given laboratory) interval for three materials tested by four laboratories is 4.314 min. In future use of this test method, the difference between two test results obtained in the same laboratory on the same material will be expected to exceed 4.314 min only about 5 % of the time.

12.3 The reproducibility (between given laboratories) interval for three materials tested by four laboratories is 31.562 min. In future use of this test method, the difference between two test results obtained in a different laboratory on the same material will be expected to exceed 31.562 min only about 5 % of the time.

13. Keywords

13.1 dead load shear; heat resistance; hot-applied sealants

The American Society for Testing and Materials takes no position respecting the validity of any patent rights asserted in connection with any item mentioned in this standard. Users of this standard are expressly advised that determination of the validity of any such patent rights, and the risk of infringement of such rights, are entirely their own responsibility.

This standard is subject to revision at any time by the responsible technical committee and must be reviewed every five years and if not revised, either reapproved or withdrawn. Your comments are invited either for revision of this standard or for additional standards and should be addressed to ASTM Headquarters. Your comments will receive careful consideration at a meeting of the responsible technical committee, which you may attend. If you feel that your comments have not received a fair hearing you should make your views known to the ASTM Committee on Standards, at the address shown below.

This standard is copyrighted by ASTM, 100 Barr Harbor Drive, PO Box C700, West Conshohocken, PA 19428-2959, United States. Individual reprints (single or multiple copies) of this standard may be obtained by contacting ASTM at the above address or at 610-832-9585 (phone), 610-832-9555 (fax), or service@astm.org (e-mail); or through the ASTM website (www.astm.org).