



Standard Guide for Calculating Movement and Other Effects When Establishing Sealant Joint Width¹

This standard is issued under the fixed designation C 1472; the number immediately following the designation indicates the year of original adoption or, in the case of revision, the year of last revision. A number in parentheses indicates the year of last reapproval. A superscript epsilon (ϵ) indicates an editorial change since the last revision or reapproval.

1. Scope

1.1 This guide provides information on performance factors such as movement, construction tolerances, and other effects that should be accounted for to properly establish sealant joint size. It also provides procedures to assist in calculating and determining the required width of a sealant joint enabling it to respond properly to those movements and effects. Information in this guide is primarily applicable to single- and multi-component, cold-applied joint sealants and secondarily to pre-cured sealant extrusions when used with properly prepared joint openings and substrate surfaces.

1.2 Although primarily directed towards the understanding and design of sealant joints for walls for buildings and other areas, the information contained herein is also applicable to sealant joints that occur in horizontal slabs and paving systems as well as various sloped building surfaces.

1.3 This guide does not describe the selection and properties of joint sealants (1), which are described by Guide C 1299, nor their use and installation, which is described by Guide C 1193.

1.4 The values and calculations stated in SI units are to be regarded as the standard. The values given in parentheses and inch-pound units are provided for information only. SI units in this guide are in conformance with IEEE/ASTM SI 10-1997.

1.5 The Committee having jurisdiction for this guide is not aware of any comparable standards published by other organizations.

1.6 *This standard does not purport to address all of the safety concerns, if any, associated with its use. It is the responsibility of the user of this standard to establish appropriate safety and health practices and determine the applicability of regulatory limitations prior to use.*

2. Referenced Documents

2.1 ASTM Standards:

- C 216 Standard Specification for Facing Brick (Solid Masonry Units Made From Clay or Shale)
- C 717 Terminology of Building Seals and Sealants

- C 719 Standard Test Method for Adhesion and Cohesion of Elastomeric Joint Sealants Under Cyclic Movement (Hockman Cycle)
- C 794 Standard Test Method for Adhesion-in-Peel of Elastomeric Joint Sealants
- C 920 Specification for Elastomeric Joint Sealants
- C 1193 Standard Guide for Use of Building Sealants
- C 1299 Standard Guide for Use in Selection of Liquid-Applied sealants
- 2.2 *American Concrete Institute (ACI) and American Society of Civil Engineers (ASCE):*
 - Building Code Requirements for Masonry Structures (ACI 530-88/ASCE 5-88) and Specifications for Masonry Structures (ACI 530.1-88/ASCE 6-88)
- 2.3 *Prestressed Concrete Institute (PCI):*
 - Manual for Quality Control for Plants and Production of Architectural Precast Concrete Products, MNL-177-77
- 2.4 *American Society of Heating, Refrigerating and Air-Conditioning Engineers, Inc. (ASHRAE):*
 - Chapter 26, Climatic Design Information, Tables 1A, 1B, 2A, 2B, 3A, 3B, ASHRAE 1997 Fundamentals Handbook
- 2.5 *Brick Institute of America (BIA):*
 - Movement, Volume Changes, and Effect of Movement, Part I, Technical Notes on Brick Construction No. 18 Revised
- 2.6 *Institute of Electrical and Electronics Engineers, Inc. (IEEE) and ASTM:*
 - IEEE/ASTM SI 10-1997 Standard for Use of the International System of Units (SI): The Modern Metric System

3. Terminology

3.1 Definitions:

3.1.1 Refer to Terminology C 717 for definitions of the following terms used in this guide: band aid sealant joint, bond breaker, bridge sealant joint, butt joint, butt sealant joint, creep, cure, cured, elongation, expansion joint, fillet sealant joint, joint, joint filler, modulus, primer, seal, sealant, sealant backing, silicone sealant, spalling, substrate

3.2 Definitions of Terms Specific to This Standard:

3.2.1 *coefficient of linear thermal movement*—an increase or decrease in unit length per unit change in material temperature of a material or assembly of materials.

¹ This standard is under the jurisdiction of ASTM Committee C24 on Building Seals and Sealants and is the direct responsibility of Subcommittee C24.10 on Specifications, Guides and Practices.

Current edition approved June 10, 2000. Published July 2000.

3.2.2 *coefficient of solar absorption*—a factor describing the capability of a material or assembly of materials to absorb a percentage of incident solar radiation.

3.2.3 *durability*—ability of a sealant joint to perform its required function over a period of time under the influence of the environment.

3.2.4 *durability limit*—point at which loss of performance leads to the end of service life.

3.2.5 *heat capacity constant*—a factor describing the capability of a material or assembly of materials to store heat generated by absorbed solar radiation.

3.2.6 *premature deterioration*—failure to achieve predicted service life.

3.2.7 *service life*—actual period of time during which no excessive expenditure is required for maintenance or repair of a sealant joint.

3.3 Symbols:

α	= Coefficient of linear thermal movement
α_B	= Coefficient of linear thermal movement for brick
α_X	= Coefficient of linear thermal movement for a particular material
A	= Coefficient of solar absorption
A_B	= Coefficient of solar absorption for brick
A_X	= Coefficient of solar absorption for a particular material
B	= Sealant backing length
C	= Compression
C_B	= Construction tolerance for brick masonry
C_X	= Construction tolerance for a particular material or system
E	= Extension
E_L	= Longitudinal extension
E_T	= Transverse extension
E_X	= Longitudinal or transverse movement for a particular condition
H	= Heat capacity constant
H_X	= Heat capacity constant for a particular material
I	= Moisture-induced irreversible growth
L	= Unrestrained length or sealant joint spacing
ΔL_B	= Dimensional change due to brick thermal movement
ΔL_C	= Dimensional change due to compression
ΔL_E	= Dimensional change due to extension
ΔL_I	= Dimensional change due to irreversible moisture movement
ΔL_L	= Dimensional change due to longitudinal extension
ΔL_P	= Dimensional change due to precast concrete thermal movement
ΔL_R	= Dimensional change due to reversible moisture movement
ΔL_T	= Dimensional change due to transverse extension
ΔL_X	= Dimensional change for a particular condition
R	= Moisture induced reversible growth
S	= Sealant movement capacity
T_A	= Hottest summer air temperature
T_{IS}	= Maximum summer installation wall surface temperature

T_{IW}	= Minimum winter installation wall surface temperature
T_S	= Hottest summer wall surface temperature
T_W	= Coldest winter wall surface temperature
ΔT_M	= Maximum expected temperature difference
ΔT_S	= Summer installation temperature difference
ΔT_W	= Winter installation temperature difference
ΔT_X	= Temperature difference for a particular condition
W	= Final designed sealant joint width
W_M	= Sealant joint width required for movement
W_R	= Sealant joint width at rest prior to movement

4. Significance and Use

4.1 Design professionals, for aesthetic reasons, have desired to limit the spacing and width of sealant joints on exterior walls and other locations of new buildings. Analysis of the performance factors and especially tolerances that affect a sealant joint is necessary to determine if a joint will have durability and be effective in maintaining a seal against the passage of air and water and not experience premature deterioration. If performance factors and tolerances are not understood and included in the design of a sealant joint, then the sealant may reach its durability limit and failure is a distinct possibility.

4.2 Sealant joint failure can result in increased building energy usage due to air infiltration or exfiltration, water infiltration, and deterioration of building systems and materials. Infiltrating water can cause spalling of porous and friable building materials such as concrete, brick, and stone; corrosion of ferrous metals; and decomposition of organic materials, among other effects. Personal injury can result from a fall incurred due to a wetted interior surface as a result of a failed sealant joint. Building indoor air quality can be affected due to organic growth in concealed and damp areas. Deterioration is often difficult and very costly to repair, with the cost of repair work usually greatly exceeding the original cost of the sealant joint work.

4.3 This guide is applicable to sealants with an established movement capacity, in particular elastomeric sealants that meet Specification C 920 with a minimum movement capacity rating of $\pm 12\frac{1}{2}$ percent. In general, a sealant with less than $\pm 12\frac{1}{2}$ percent movement capacity can be used with the joint width sizing calculations; however, the width of a joint using such a sealant will generally become too large to be practically considered and installed. It is also applicable to precured sealant extrusions with an established movement capacity, although there presently is no ASTM specification for these materials.

4.4 The intent of this guide is to describe some of the performance factors and tolerances that are normally considered in sealant joint design. Equations and sample calculations are provided to assist the user of this guide in determining the required width and depth for single and multi-component, liquid-applied sealants when installed in properly prepared joint openings. The user of this guide should be aware that the single largest factor contributing to non-performance of sealant joints that have been designed for movement is poor workmanship. This results in improper installation of sealant and sealant joint components. The success of the methodology described by this guide is predicted on achieving adequate workmanship.

4.5 Joints for new construction can be designed by the recommendations in this guide as well as joints that have reached the end of their service life and need routine maintenance or joints that require remedial work for a failure to perform. Guide C 1193 should also be consulted when designing sealant joints. Failure to install a sealant and its components following its guidelines can and frequently will result in failure of a joint design.

4.6 Peer reviewed papers, published in various ASTM Special Technical Publications (STP), provide additional information and examples of sealant joint width calculations that expand on the information described in this guide (2-5). For cases in which the state of the art is such that criteria for a particular condition is not firmly established or there are numerous variables that require consideration, a reference section is provided for further consideration.

4.7 To assist the user of this guide in locating specific information, a detailed listing of guide numbered sections and their headings is included in Appendix X1.

5. Performance Factors

5.1 *General*—Proper sealant joint design can not be adequately performed without a knowledge and understanding of factors that can affect sealant performance. The following describes most of the commonly encountered performance factors that are known to influence sealant joint design. These performance factors can act individually or, as is mostly the case, in various combinations depending on the characteristics of a particular joint design.

5.2 *Material and System Anchorage*—The type and location of various wall anchors has an impact on the performance of a sealant joint (6). Large precast concrete panels with fixed and moving anchors, brick masonry support system deflection between supports (3), and metal and glass curtain wall fixed and moving anchorages are examples of anchorage conditions that must be considered and evaluated when designing sealant joints for movement. Anchor types and their locations have an effect on determining the effective length of wall material or support system deflection characteristics that need to be included when designing for sealant joint width.

5.3 *Thermal Movement*—Walls of buildings respond to ambient temperature change, solar radiation, wetting and drying effects from precipitation, and varying cloud cover by either increasing or decreasing in volume and therefore in linear dimension. The dimensional change of wall materials causes a change in the width of a sealant joint opening, producing a movement in an installed sealant. Thermal movement is the predominate effect causing dimensional change.

5.3.1 Thermal movement may need to be evaluated at different stages in a building's life; for example, expected temperature differentials may need to be considered for the building when it is: 1) under construction, 2) unoccupied and unconditioned, and 3) occupied and conditioned. Each of these stages will have different interior environmental conditions, and depending on the building enclosure material or system being analyzed for movement, one of those stages may produce the maximum expected thermal movement. The required joint

opening width, depending on construction procedures and material or wall system types, could be established during one of those stages.

5.3.2 Determining realistic material or wall surface temperatures to establish the expected degree of thermal movement can be challenging. The ASHRAE Fundamentals Handbook, Chapter 26 Climatic Design Information, lists winter and summer design dry bulb air temperatures for many cities. These listed values can be used to assist in calculating expected surface temperatures for use in joint width calculations. For convenience, dry bulb air temperatures for selected North American locations have been included in Table 1.

5.4 *Thermal Movement Environmental Influences*—The effect of a sudden rain shower or the clouding over of the sky may also have to be considered (6). Both of these events can cause a wall material to change in temperature and therefore dimension. Moisture wetting a warm wall surface cools it and clouds preventing solar warming of the surface produce the same effect. These effects, depending on the wall system or material, its solar absorptivity, and color, can cause either a time lag and slow rate of movement in a sealant joint for a concrete panel or masonry system, or an almost immediate and fairly rapid rate of movement for a sealant joint in a lightweight, highly insulated, metal and glass curtain wall.

5.5 *Coefficient of Linear Thermal Movement*—In addition to the temperature extremes a wall material will experience, its coefficient of linear thermal movement (α) must also be determined. Table 2 lists average coefficients of linear thermal movement for some of the commonly used construction materials. For most applications, it is acceptable to use the values for the materials listed in Table 2. For some materials and applications, the relationship between temperature and linear dimension, over the expected temperature exposure range, may not be truly linear for the entire range. For a sensitive application, it may be necessary to determine the actual linear dimensional response of a material for discrete segments of its service temperature range. This may result in different linear coefficients for those segments of the service temperature range. These values would then be used in the calculations to determine sealant joint width. Additionally, absorbed moisture can also affect the thermal movement coefficient of a porous material. The coefficient of thermal movement of a saturated material can be as high as twice that of the dry material. This effect is different from the moisture-induced movement effect described in 5.6. Lastly, for a wall or panel system construction that is a composite of materials, an appropriate coefficient of linear thermal movement should be determined for the composite assembly.

5.6 *Moisture Induced Growth*—Some materials respond to changes in their water or water vapor content by increasing in dimension when water content is high and decreasing in dimension when water content is low. This effect can be reversible or irreversible (7). Materials susceptible to a reversible effect are generally porous and include wood, some natural building stones, concrete, face brick, and concrete block. Some materials are susceptible to an irreversible change in dimension with the passage of time. For example, a fired clay product, such as a brick, will slowly increase in size, following its firing

TABLE 1 Dry Bulb Air Temperatures T_w and T_a for Selected North American Locations
 Temperatures indicated in degrees Celsius ($^{\circ}\text{C}$) and degrees Fahrenheit ($^{\circ}\text{F}$)

Location	Winter		Summer		Location	Winter		Summer	
	99.6 % Value		0.4 % Value			99.6 % Value		0.4 % Value	
	$^{\circ}\text{C}$	$^{\circ}\text{F}$	$^{\circ}\text{C}$	$^{\circ}\text{F}$		$^{\circ}\text{C}$	$^{\circ}\text{F}$	$^{\circ}\text{C}$	$^{\circ}\text{F}$
Birmingham, AL	-8	18	34	94	Albuquerque, NM	-11	13	36	96
Mobile, AL	-3	26	34	94	Gallup, NM	-18	-1	32	89
Anchorage, AK	-26	-14	22	71	Albany, NY	-22	-7	32	90
Fairbanks, AK	-44	-47	27	81	New York, NY	-11	13	33	92
Flagstaff, AZ	-17	1	29	85	Raleigh/Durham, NC	-9	16	34	93
Phoenix, AZ	1	34	43	110	Grand Forks, ND	-29	-20	33	91
Fayetteville, AR	-14	6	35	95	Columbus, OH	-17	1	32	90
Little Rock, AR	-9	16	36	97	Oklahoma City, OK	-13	9	37	99
Los Angeles, CA	6	43	29	85	Portland, OR	-6	22	32	90
San Francisco, CA	3	37	28	83	Harrisburg, PA	-13	9	33	92
Denver, CO	-19	-3	34	93	Providence, RI	-15	5	32	89
Hartford, CT	-17	2	33	91	Charleston, SC	-4	25	34	94
Wilmington, DE	-12	10	33	91	Rapid City, SD	-24	-11	35	95
Miami, FL	8	46	33	91	Nashville, TN	-12	10	34	94
Tallahassee, FL	-4	25	35	95	Dallas/Fort Worth, TX	-8	17	38	100
Atlanta, GA	-8	18	34	93	Houston, TX	-2	29	34	94
Honolulu, HI	16	61	32	89	Salt Lake City, UT	-14	6	36	96
Boise, ID	-17	2	36	96	Burlington, VT	-24	-11	31	87
Idaho Falls, ID	-24	-12	33	92	Richmond, VA	-10	14	34	94
Chicago, IL	-21	-6	33	91	Seattle, WA	-5	23	29	85
Rockford, IL	-23	-10	33	91	Spokane, WA	-17	1	33	92
Indianapolis, IN	-19	-3	33	91	Huntington, WV	-14	6	33	91
Des Moines, IA	-23	-9	34	93	Madison, WI	-24	-11	32	90
Sioux City, IA	-24	-11	34	94	Wausau, WI	-26	-15	31	88
Wichita, KS	-17	2	38	100	Casper, WY	-25	-13	33	92
Louisville, KY	-14	6	34	93	Cheyenne, WY	-22	-7	31	87
New Orleans, LA	-1	30	34	93					
Caribou, ME	-26	-14	29	85	Edmonton, Alberta	-33	-28	28	82
Portland, ME	-19	-3	30	86	Vancouver, BC	-8	18	24	76
Baltimore, MD	-12	11	34	93	Winnipeg, Manitoba	-33	-27	31	87
Boston, MA	-14	7	33	91	Saint John, NB	-23	-9	26	78
Detroit, MI	-18	0	32	90	Gander, NF	-20	-4	26	79
Marquette, MI	-25	-13	29	85	Chesterfield, NWT	-37	-35	19	66
International Falls, MN	-34	-29	30	86	Halifax, NS	-19	-2	27	80
Minneapolis-St. Paul, MN	-27	-16	33	91	Toronto, Ontario	-20	-4	31	87
Jackson, MS	-6	21	35	95	Charlottetown, PEI	-21	-6	26	79
Kansas City, MO	-18	-1	36	96	Montreal, Quebec	-24	-12	29	85
Billings, MT	-25	-13	34	93	Regina, Saskatchewan	-34	-29	32	89
Omaha, NE	-22	-7	35	95	Whitehorse, YT	-37	-34	25	77
Ely, NV	-21	-6	32	89					
Las Vegas, NV	-3	27	42	108	Acapulco	20	68	33	92
Concord, NH	-22	-8	32	90	Mexico City	4	39	29	84
Newark, NJ	-12	10	34	93	Veracruz	14	57	34	94

Table 1 data has been extracted from the 1997 ASHRAE Fundamentals Handbook, Chapter 26, Tables 1A, 1B, 2A, 2B, 3A, and 3B. Section 7.2 illustrates use of the data.

in a kiln, as its moisture content increases while equilibrating with the environment.

5.6.1 Table 3 provides values (as a percent dimensional change) for moisture induced reversible growth (R) as well as irreversible growth (I) for various types of materials (8). In general, cement-based products decrease in dimension and fired clay products increase in dimension irreversibly as they equilibrate with the environment. Reversible growth is based on the likely extremes of in-service moisture content and irreversible growth on the period from material manufacture to its maturity. The use of steel reinforcement will usually lessen the Table 3 concrete values. For clay masonry in Table 3, the ACI 530.1-88/ASCE 6-88 and BIA Technical Notes on Brick Construction No. 18 recommended value of 0.03 can be used for I in lieu of the range of values, if appropriate. These listed values can be used to assist in calculating moisture growth effects for use in joint width calculations. Section 7.5 illustrates use of the data.

5.6.2 For sealant joints, the dominant effect on a reversible change in joint width is usually due to temperature change of a material or system. The inclusion of reversible moisture-induced growth with thermal movement may not be a truly additive effect. Moisture content tends to decrease with a rise in wall surface temperature and increase with a drop in wall surface temperature, thereby producing thermal movement and moisture-induced growth that are somewhat compensating but that may not necessarily occur simultaneously. The net sealant joint movement due to thermal and moisture effects may be difficult or impossible to determine, so some judgment must be used by the design professional when reversible moisture growth is considered (See 7.5.1).

5.7 *Live Load Movement*—Deflection caused by structure or floor live loading should be considered for a horizontal sealant joint opening, as is done for example, in designing a joint for multi-story construction (3). A structural engineer can supply live load deflection criteria for sealant joint design.

TABLE 2 Average Coefficients of Linear Thermal Movement (α) for Some Building Materials
(multiply by 10^{-6})

NOTE 1—The coefficient of movement for natural materials (brick, stone, wood, etc.) or fabrications of natural materials can be highly variable. If a specific material is contemplated then the coefficient for that material should be established and used rather than an average value.

Materials	Celsius (mm/mm/°C)	Fahrenheit (in/in/°F)	Materials	Celsius (mm/mm/°C)	Fahrenheit (in/in/°F)
Aluminum:			Plastic:		
5005 alloy	23.8	13.2	Acrylic sheet	74.0	41.0
3003 alloy	23.2	12.9	High impact acrylic	82.0	50.0
6061 alloy	23.8	13.2	Polycarbonate	68.4	38.0
Brass:			Steel, carbon	12.1	6.7
230 alloy	18.7	10.4	Steel, stainless:		
Bronze:			301 alloy	16.9	9.4
220 alloy	18.4	10.2	302 alloy	17.3	9.6
385 alloy	20.9	11.6	304 alloy	17.3	9.6
655 alloy	18.0	10.0	316 alloy	16.0	8.9
Clay masonry:			410 alloy	11.0	6.1
Clay or shale brick	6.5	3.6	430 alloy	10.4	5.8
Fire clay brick or tile	4.5	2.5	Stone:		
Clay or shale tile	5.9	3.3	Granite	5.0-11.0	2.8-6.1
Concrete masonry:			Limestone	4.0-12.0	2.2-6.7
Dense Aggregate	9.4	5.2	Marble	6.7-22.1	3.7-12.3
Lightweight aggregate	7.7	4.3	Sandstone	8.0-12.0	4.4-6.7
Concrete:			Slate	8.0-10.0	4.4-5.6
Calcareous aggregate	9.0	5.0	Travertine	6.0-10.0	3.3-5.6
Silicious aggregate	10.8	6.0	Tin	21.1	11.7
Quartzite aggregate	12.6	7.0	Wood:		
Copper			Parallel to fiber		
110 alloy, soft	16.9	9.4	Fir	3.8	2.1
110 alloy, cold rolled	17.6	9.8	Maple	6.5	3.6
122 alloy	16.9	9.4	Oak	4.9	2.7
Glass	9.0	5.0	Pine	5.4	3.0
Iron			Perpendicular to fiber		
Cast, grey	10.6	5.9	Fir	57.6	32.0
Wrought	12.6	6.7	Maple	48.6	27.0
Lead	28.6	15.9	Oak	54.0	30.0
Magnesium	28.8	16.0	Pine	34.2	19.0
Monel	14.0	7.8	Zinc:		
Plaster, gypsum:			Rolled	31.3	17.4
Sand aggregate	11.7-12.2	6.5-6.75	Alloy, with grain	23.4	13.0
Perlite aggregate	13.1-13.2	7.3-7.35	Alloy, across grain	17.6	9.8
Vermiculite aggregate	15.1-15.5	8.4-8.6			

TABLE 3 Coefficients of Linear Moisture Growth for Some Building Materials

NOTE 1—(–) indicates a reduction, (+) indicates an increase, and NA not available.

Materials	Growth, Percent	
	Reversible (R)	Irreversible (I)
Concrete:		
Gravel aggregate	0.02-0.06	0.03-0.08 (–)
Limestone aggregate	0.02-0.03	0.03-0.04 (–)
Lightweight aggregate	0.03-0.06	0.03-0.09 (–)
Concrete masonry:		
Dense aggregate	0.02-0.04	0.02-0.06 (–)
Lightweight aggregate	0.03-0.06	0.02-0.06 (–)
Clay masonry:		
Clay or shale brick	0.02	0.02-0.09 (+)
Stone:		
Limestone	0.01	NA
Sandstone	0.07	NA

5.7.1 Actual live loads can be highly variable (9). A multi-story building, with the same design live load for all floors, will have the actual live load (which can be substantially less than a code prescribed value) vary from floor to floor and from one area of a floor to another. Very rarely will the live load be uniform everywhere. Where live load (and thus

deflection) of a structure varies, the relative difference in live load deflection between floors should be considered in joint width design.

5.7.2 Most often live load deflection occurs after the joint has been sealed and, therefore, could be considered an irreversible narrowing of the sealant joint opening, provided the loading conditions remain relatively static. If live loading will be highly variable, such as in a warehouse, then live load deflection could be treated as a reversible movement. The design professional should evaluate these situations and determine how live load deflection is best accommodated.

5.8 *Dead Load Movement*—Deflection caused by structure or floor dead loading should also be considered for a horizontal sealant joint opening (3). A structural engineer can supply dead load deflection criteria for sealant joint design. Dead load deflection of a structure usually occurs before a joint is sealed. There may be a portion that could occur after a joint has been sealed; for instance, when fixed equipment may be installed. Dead load deflection is an irreversible narrowing of a sealant joint opening width for most applications. In multi-story construction, dead load deflection that narrows a sealant joint opening at one floor may have a tendency to widen the sealant joint opening at the floor above.

5.9 *Wind Load Movement*—Depending on building type, framing system, and anticipated wind load, lateral sway or drift of a building and its effect on a sealant joint in a wall may have to be considered (10). The per-story lateral sway or drift can be determined by a structural engineer. Lateral sway or drift can occur both normal to and in the plane of the wall and both effects on a sealant joint should be considered.

5.10 *Seismic Movement*—In general, sealant joints can be designed for seismic movement. However, the width of the joint to accommodate the expected movement may become large and visually objectionable. Installation of sealant in a large opening can be impractical or may require special techniques. In general, it is usually more appropriate to use readily available preformed gasket systems rather than a liquid-applied sealant for these applications.

5.11 *Movement During Sealant Curing*—The movement capability of sealant is established by laboratory testing of small specimens using Test Method C 719, after a sealant has been allowed to cure and attain its intended properties. Experience garnered from sealant joint failures has indicated that some joints will experience movement after installation, sometimes sizable, during the period when the sealant is curing (11). The character of the materials or systems in which the joint occurs is a significant factor in determining the degree and rate of movement that will occur. Building monitoring has shown that materials or systems with high thermal mass experience low rates of movement while those of low mass, that are well insulated, experience high rates of movement (6). With solar warming, the rate of change of a material or system surface temperature closely correlates with the rate of movement of a sealant joint. Other studies have described the character of sealant joint failures due to movement during cure and have shown that movement during cure can alter the cured performance characteristics of a sealant (12-15). Performance parameters that can be altered include tensile strength, compressive strength, modulus, adhesion to substrates, and sealant tear resistance. Physical aspects that can be altered include introduction of exposed and hidden surface cracking and production of voids within the body of the sealant. These types of changes or damage could be detrimental for the sealant joint if of a sufficient magnitude. The type and degree of these changes for a particular sealant will vary depending on the generic polymer backbone and particular sealant formulation. As a result of these effects that can occur during sealant cure, the ultimate movement capability of a sealant can be adversely affected. The calculations in this guide are based on cured sealant properties. If a particular installation can not avoid a movement during cure situation from occurring, then compensation for lessened ultimate sealant properties should occur. Compensation can include installing the sealant and allowing it to cure at times of least expected movement or testing a particular sealant to the movement during cure characteristics expected to occur and then designing the joint appropriately. Guide C 1193 should be consulted for an in-depth discussion of movement-during-cure.

5.12 *Elastic Frame Shortening*—Multi-story concrete structures, and to a lesser degree steel, shorten elastically almost immediately due to the application of loads (9, 10, 16). Frame

shortening, the degree of which can be estimated by a structural engineer, will cause an irreversible narrowing of a horizontal sealant joint opening in multi-story construction. Frame shortening can be compensated for by building each floor level higher, in effect negating most of the shortening, or the narrowing of joint width can become another performance factor considered in the design of a sealant joint. Some of the frame shortening effect will occur before the wall cladding is erected and the size of the joint opening is established. Presently, it is common practice to determine the amount of shortening that occurs before the joint opening is established using an informed and conservative estimate.

5.13 *Creep*—The time-dependent deformation of materials while loaded, in particular for a concrete structure, should be included in sealant joint design. This deformation, which occurs at a decreasing rate as time progresses, can cause a continuing decrease in the width of horizontal joint openings in multi-story and other buildings. Creep, in contrast to elastic frame shortening, can occur over a long period of time (9, 10, 16). A structural engineer can provide creep deflection criteria for sealant joint design.

5.14 *Shrinkage*—Concrete framed structures will undergo long-term shrinkage for a period of months (9, 10, 16). Other cement based systems, such as load-bearing concrete masonry unit construction, can also experience the same effect. Shrinkage is mainly due to loss of moisture during the initial curing of concrete. The rate of shrinkage is dependent on the amount of water present, ambient temperatures, rate of air movement, relative humidity of the surrounding air, the shape and size of the concrete section, and the amount and type of aggregate in the concrete mix, among others. Table 3 and Reference (8) list guidelines for some shrinkage values for concrete and other materials. Shrinkage criteria can be provided by a structural engineer and included in sealant joint design or the shrinkage effect can be somewhat compensated for by building each floor level slightly higher. In any event, shrinkage effects should be included in the design of a horizontal joint in multi-story construction. Some of the frame shrinkage effect will occur before a wall cladding is erected and the size of the joint opening is established. Presently, the amount of shrinkage that occurs before a joint opening is established is determined by an informed estimate and, therefore, should be conservative.

5.15 *Construction Tolerances*—A typical building is a combination of site-built and factory fabricated materials, components, and sub-systems. These materials and systems can be combined and constructed in complex arrangements. ASTM and industry trade associations, among others, establish industry recognized standards for construction tolerances (17). Industry established tolerances should be carefully evaluated since, in some cases, they can be quite liberal and not appropriate for sealant joint design. For some materials or systems there are no industry recognized tolerances or the available tolerances are not directly applicable to sealant joint design. In these instances, a design professional should evaluate the conditions and establish tolerances for sealant joint work. A word of caution: ignoring the effects of construction tolerances, when designing sealant joints, will very often result in a failure of the joint, and frequently a failure of adjacent

materials or systems that, due to the joint narrowing, may come into detrimental contact with each other. Conversely, changing construction tolerances, by exceeding industry recommendations, needs to be carefully considered, since conditions can be created that can not be effectively achieved. Construction tolerances should be indicated for the sealant joint design since they establish a level of quality and may affect the cost and performance of the work. Experience has indicated that, in general, if tolerances are not adequately considered, sealant joints become too narrow, not too large. It is beyond the scope of this guide to describe the effects of tolerances in detail. Reference 17 should be consulted as well as industry specific standards.

5.15.1 *Material*—Construction materials have a permissible variation for their dimensions. For example, a face brick is nominally 57 mm (2-1/4 in) high by 203 mm (8 in) long by 89 mm (3-1/2 in) thick. Depending on the type of brick, the permissible manufacturing tolerance or variation could be as much as 4 to 6 mm (5/32 to 1/4 in) for the 203 mm (8 in) dimension, as indicated by Specification C 216. Material dimensional variation may have to be included as a performance factor in the design of a sealant joint. If material tolerance is not considered, an improper sealant joint width could result.

5.15.2 *Fabrication*—Fabricated materials or assemblies of materials also have dimensional variance. Factory fabrication will usually permit a smaller variation in dimension than job site fabrication. For example, factory fabricated unitized metal and glass curtain wall frames may permit ± 2 mm (1/16 in) tolerance or less for the length and width of the frames, while job site assembly of a face brick wall, depending on brick type, may permit no better than ± 6 mm (1/4 in) variance for the constructed width of an expansion joint opening in a wall. Also, a precast concrete wall panel that is 9.1 m (30 ft) long, according to MNL-177-77, can have a tolerance for that dimension at the time of casting of +3, -6 mm (+1/8, -1/4 in). Realistic fabrication tolerances should be established and enforced so that the designed joint opening width is attained and sealant performance is not compromised, especially by a joint opening that is constructed too narrow in width.

5.15.3 *Erection*—Frequently, wall materials or systems cannot be placed on a building exactly where called for by the contract documents. Some location variance for building com-

ponents should be provided so that a deficient joint opening width does not occur. For example, a unitized metal and glass curtain wall frame may be erected no closer than ± 3 mm (1/8 in) to height or lateral locations shown by the contract documents. The precast concrete wall panel described in 5.15.2, according to MNL-177-77, may not be able to be placed any closer to its theoretical location than ± 6 mm ($\pm 1/4$ in). Locational variance of materials or systems will affect the constructed width of a sealant joint opening that occurs between wall elements. Erection tolerances must be intelligently developed so that they are realistic and also attainable at the building site.

5.15.4 *Accumulated Tolerances*—When several materials, components, or subsystems are combined on the face of a building their respective tolerances may not be additive. For example, not all materials, components, or subsystems will be oversize or undersize. Statistically, it is likely that there will be a mix of under and oversize and unlikely that all would be over or under size. It is possible to statistically account for several combined tolerances to arrive at a probable total tolerance. There is not an industry consensus on a standardized method to account for combined tolerances; however, Reference (17) can be consulted for guidance.

6. Sealant Joint Movement

6.1 *General*—There are four basic movements that sealant joints experience (See Fig. 1). These movements are: compression (C), extension (E), longitudinal extension (E_L), and transverse extension (E_T). Longitudinal and transverse extension produce a shearing effect on a sealant joint (See Fig. 2). Thermal movement is usually the largest contributor; however, other performance factors can contribute to producing these movements. The following describes these movements.

6.2 *Compression*—A sealant joint that primarily experiences compression (C), a narrowing of the opening width, is typically one where the sealant is installed during the cool or cold months of the year. Therefore, when the warm summer months occur the thermal growth of adjacent materials causes a narrowing of the sealant joint opening, thereby compressing the sealant.

6.3 *Extension*—A sealant joint that primarily experiences extension (E), an increase in the opening width, is typically one

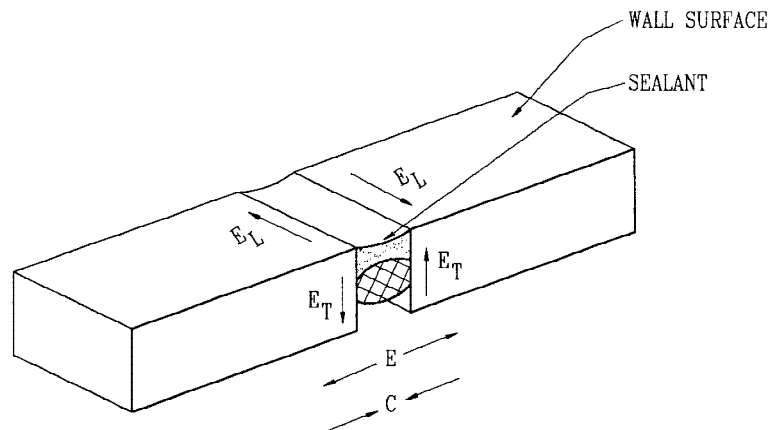

FIG. 1 Typical Sealant Joint Movements

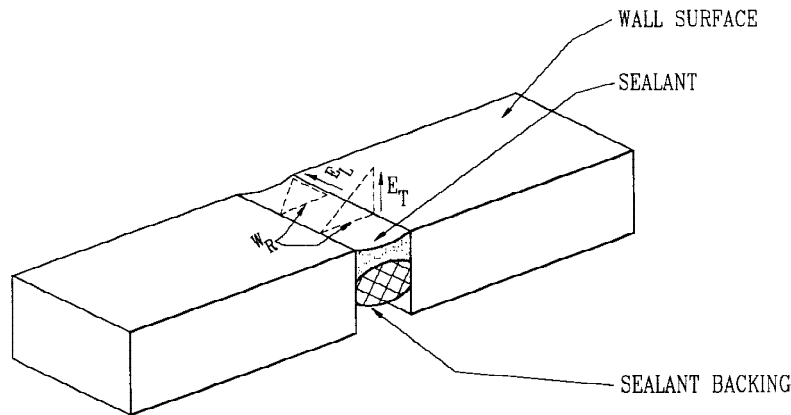

FIG. 2 Longitudinal or Transverse Extension Movement

where the sealant is installed during the warm months of the year. Therefore, when the cool or cold months occur the thermal contraction of adjacent materials causes a widening of the joint opening, thereby extending the sealant.

6.4 *Extension and Compression*—A sealant joint installed during the fall or spring months, or when temperatures are moderate, can experience both compression (C) as well as extension (E) since the sealant is not installed at or near the hottest or coldest design temperatures. This results in compression during the summer months and extension during the winter months, however typically neither movement is as large as would occur as described in 6.2 or 6.3.

6.5 *Longitudinal Extension*—A sealant joint that experiences longitudinal extension (E_L), a lengthwise shearing type of displacement of one side of the joint relative to the other, is typically one that has different materials or systems forming the sides of the joint or the same material on both sides of the joint but with different support conditions for both sides (See Fig. 2). Examples of this effect include a brick masonry wall on one side and an aluminum curtain wall mullion for the other, or a face brick veneer on both sides but supported periodically by shelf angles on one side and at grade on the other. These different materials or support conditions will result in different responses to the same temperature change, resulting in a diagonal lengthening of the sealant due to the differential movement between the materials. The movement is in a direction parallel to the joint opening. This movement is

dependent on the location of each materials' supports, the unrestrained length of the respective materials, and the expected temperature change for each material. This movement usually reaches its maximum only along part of the length of a sealant joint. Irreversible moisture growth of fired clay products such as face brick can also contribute to the effect.

6.6 *Transverse Extension*—A sealant joint that experiences transverse extension (E_T), a shearing type of out-of-plane movement crosswise to the joint face, of one side of the joint opening relative to the other, is typically one that occurs at the juncture of walls that change plane, such as at a corner. As the materials forming the sides of the joint experience thermal movement, a diagonal lengthening of the sealant can occur crosswise to the plane of the sealant joint face. (See Fig. 2.)

6.7 *Movement Combinations*—Frequently, sealant joints must accommodate more than one of the above described movements. Examples include the previously described extension and compression, as well as extension and/or compression combined with longitudinal or transverse extension. Fig. 3 is representative of extension and compression combined with transverse extension movement crosswise to the plane of the joint (See 6.6). Fig. 4 is representative of extension and compression combined with longitudinal extension movement in the plane of the joint (See 6.5). The effects of these movements can be combined to establish the joint width required to satisfy those expected combined movements. The

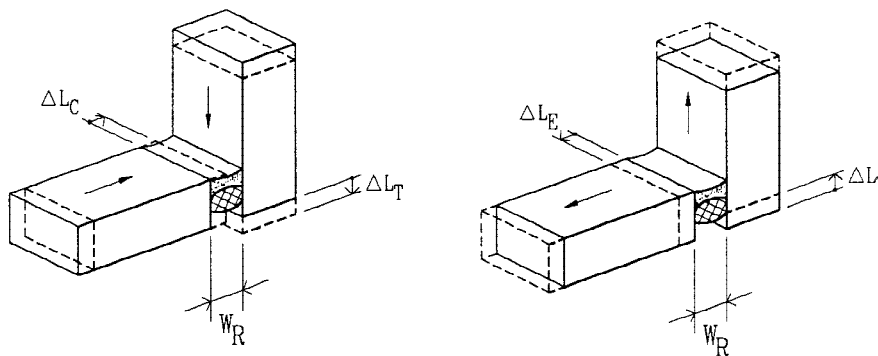

A. COMPRESSION WITH EXTENSION

B. EXTENSION MOVEMENTS

FIG. 3 Extension and Compression Movement with Transverse Extension

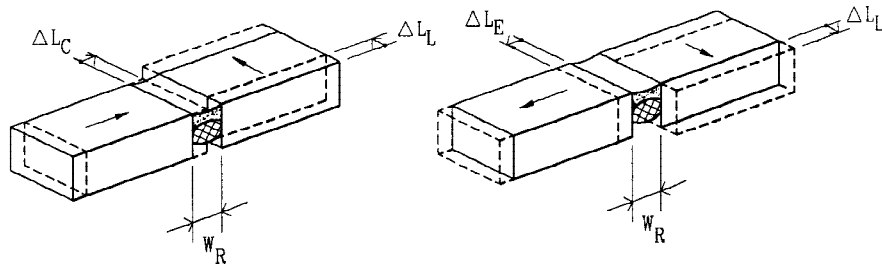

A. COMPRESSION WITH EXTENSION
 B. EXTENSION MOVEMENTS
FIG. 4 Extension and Compression Movement with Longitudinal Extension

design professional should evaluate the types of movement the joint will experience and design accordingly.

6.8 *Sealant Stresses in Extension and Shear*—Testing has been performed on various polyurethane and silicone sealants to establish how shear stresses produced in those sealants, when in longitudinal or transverse extension, compare with the tensile stresses produced when the sealants were in extension (18). The results of that work indicate that the use of a trigonometric equation, based on the triangular relationship indicated by Fig. 2, in conjunction with a sealant's tensile modulus properties, can successfully predict allowable shear movement for a sealant joint, since the shear stress did not exceed the tensile stress for a given elongation (See 7.6.3).

6.9 *Sealant Movement Capability and Rating*

6.9.1 *Liquid-Applied Sealant*—Sealant manufacturers rate the movement capability of their liquid-applied sealants, generally, as a plus-minus value. Liquid-applied sealants, that meet Specification C 920 are rated as $\pm 12\frac{1}{2}$ or ± 25 percent. This value is determined primarily by Test Method C 719. Some sealant manufacturers also market sealants that are indicated to have a ± 50 percent rating based on Test Method C 719. To achieve the rated movement capacity, it is important to verify that a particular sealant will adhere to a particular substrate and that the movement rating is applicable to a particular set of circumstances. For example, a particular sealant may adhere to an unprimed brick masonry substrate but not to an unprimed concrete substrate. It is prudent for the joint designer to have the sealant manufacturer test, using Test Method C 794, a particular sealant with actual samples of a particular substrate prior to sealant installation. Sealant manufacturers, in general, state that a sealant will adhere to a generic substrate; however, it is always prudent to have a particular sealant and substrate combination tested for adequate adhesion both with and

without a primer. Without adequate long-term adhesion a sealant's movement capability is irrelevant. The joint designer, after establishing that there is adequate adhesion, is faced with a fundamental decision. Should the sealant be used at its manufacturer's rating? If performance factors and tolerances can not be adequately identified then using the sealant at less than its manufacturer's rating would be prudent. The quality of expected workmanship can also be a factor to be considered when establishing the sealant movement rating that will be used for calculation. Additionally, it should be realized that test Method C 719 is only a 10 cycle test procedure that may not adequately describe characteristics that affect sealant movement capability and may not adequately predict long-term performance and durability. Also, if remedial sealant work is to be performed using already contaminated substrates, as would occur when resealing a previous sealant failure, then using the sealant at a lessor value than its rating may also be prudent. In this case, using it at less than its rating would cause less stress to develop at the sealant's adhesion to the substrate, where it may not be possible to attain optimum adhesion. Using a sealant at a lessor value than its rating does not mean that laboratory and field adhesion tests are not required. They should always be performed. The amount of reduction in movement capacity from the manufacturers rating is mostly a judgement call, based on experience and a joint design's particular circumstances.

6.9.2 *Precured Sealant Extrusion*—These products are formulated and extruded by the manufacturer to provide a precured, low-modulus shape that is then adhered in-place (See Fig. 5). Presently, there is no ASTM specification that describes precured sealant extrusion properties. Sealant manufacturers rate the movement capability of precured sealant extrusions, generally, as a plus-minus value. Presently, a movement

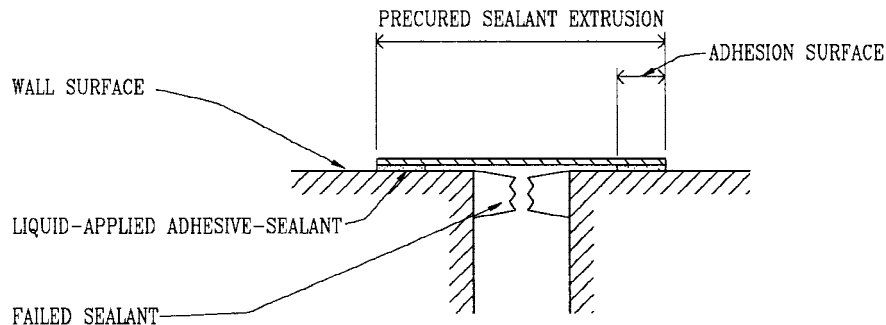

FIG. 5 Cross-Section of a Typical Precured Sealant Extrusion Application

capability of +200, -50 and +200, -75 percent are representative of currently available products. Manufacturers indicate that these values are determined primarily by a modified Test Method C 719. A precured sealant extrusion is adhered to a substrate surface using a compatible liquid-applied sealant. The same concerns indicated in 6.9.1 relative to adhesion and movement capability also apply to these products. In particular, adhesion of the compatible liquid-applied sealant and the movement rating of the precured sealant extrusion.

7. Equations

7.1 *General*—Once the factors that affect sealant joint performance are identified for a particular application, the following equations can be used to quantify these effects. Surface temperatures and the degree of various movements are calculated and then used to calculate the required width of a sealant joint to satisfy the movement(s). Lastly, the effects of construction tolerance(s) and the depth of the sealant joint are established and included in the joint design.

7.2 *Surface Temperature:*

7.2.1 *General*—The following theoretical calculations that are used to establish wall or other surface temperatures have not been verified by in situ evaluations of actual wall or other surface temperatures to verify the accuracy of the calculation methodology. However, it is believed that these calculations will tend to establish surface temperatures that will be conservative.

7.2.2 *Winter*—The coldest winter wall surface temperature (T_w) can be established using the winter heating design dry bulb air temperature. Generally, this is realistic since the exterior wall surface will be within a few degrees of the air temperature, depending on the degree of insulation of the wall and a lack of solar radiation. The ASHRAE Fundamentals Handbook, Tables 1A for locations within the United States, 2A for locations in Canada, and 3A for international locations list the 99 and 99.6 percent heating season dry bulb temperatures. These dry bulb temperatures are exceeded (are lower) on average for 88 and 35 hours per year respectively. The coldest temperature, the 99.6 value, should be used for calculation. Performing a steady state heat flow calculation to determine a surface temperature does not seem necessary for most uses.

7.2.2.1 For example, to determine the coldest expected winter wall surface temperature (T_w) for a wall that will be located in Detroit, Michigan, Table 1A from the ASHRAE Handbook of Fundamentals indicates a value of -18°C (0°F) for the 99.6 percent dry bulb temperature. For convenience, dry bulb air temperatures for selected North American locations have been included in Table 1 of this guide.

7.2.2.2 Depending on climatic conditions, an evaporative cooling effect of absorbed moisture from a porous material could cause its surface temperature to be less than the air temperature. For this condition, it may be more appropriate to determine and use a material's wet bulb temperature. Additionally, nighttime cloudless climatic conditions could also cause a cooling effect, due to black-body radiation, that could also cause a wall surface temperature, particularly the more it is inclined from a vertical orientation, to be less than the air temperature.

7.2.3 *Summer*—The hottest summer wall surface temperature (T_s) can be established as follows. The starting point is the ASHRAE Handbook of Fundamentals, Tables 1B, 2B, and 3B which list 0.4, 1, and 2 percent cooling season dry bulb air temperatures. These dry bulb temperatures on average are exceeded (are higher) for 35, 88, and 175 hours per year respectively. To determine the hottest expected summer air temperature (T_A), the 0.4 percent dry bulb air temperature should be used for calculation. For convenience, dry bulb air temperatures for selected North American locations have been included in Table 1 of this guide.

$$T_s = T_A + A_x(H_x) \tag{1}$$

7.2.3.1 Walls also receive solar radiation which warms a wall surface above the air temperature. Wall surface solar heat gain, the product of a material's solar absorption coefficient (A) obtained from Table 4, and its heat capacity constant (H) obtained from Table 5, must be added to T_A when determining T_s , by using Eq 1.

7.2.3.2 Table 5 lists some values for H to use in Eq 1. The heat capacity constant (H) should be used with the following guidelines. Low heat storage capacity materials or walls are represented by well insulated metal panel curtain walls; and high heat storage capacity materials or walls are represented by precast concrete or brick masonry. If light colored or other reflective adjacent surfaces reflect solar radiation to the wall surface, then constants that include this effect should be used in lieu of the previous constants (19).

7.2.3.3 For example, to determine the maximum expected surface temperature of a red brick wall in Detroit, Michigan, the coefficient of solar absorption (A_B) for the brick is first obtained from Table 4. A range of values is indicated, so, to be conservative, the high value is used. If the specific coefficient of solar absorption for a particular material is known then that value should be used rather than the table values. The hottest summer wall surface temperature (T_s), is determined using Eq

TABLE 4 Coefficients of Solar Absorption for Some Building Materials

NOTE 1—Table 4 coefficients are dimensionless.

Material	Coefficient (A)	Material	Coefficient (A)
Aluminum:		Glass:	
Clear finish	0.60	Clear, 6 mm (¼ in)	0.15
Dull	0.40-0.65	Tinted, 6 mm (¼ in)	0.48-0.53
Paint	0.40	Reflective, 6 mm (¼ in)	0.60-0.83
Black, nonmetallic:		Marble, white	0.58
Asphalt, slate	0.85-0.98	Paint	
Mineral board:		Dark red, brown or green	0.65-0.85
Uncolored	0.75	Black	0.85-0.98
White	0.61	White	0.23-0.49
Clay masonry:		Plaster, white	0.30-0.50
Brick, light buff (yellow)	0.50-0.70	Steel, rusted	0.65-0.85
Brick, red color	0.65-0.85	Surface Color:	
Brick, white	0.25-0.50	Black	0.95
Concrete, uncolored	0.65	Dark Grey	0.80
Copper:		Light Grey	0.65
Tarnished	0.80	White	0.45
Patina	0.65	Tinned surface	0.05
Galvanized steel,	0.40-0.65	Wood, smooth	0.78
Galvanized steel, white	0.2		

TABLE 5 Heat Capacity Constants

NOTE 1—Table 5 indicates coefficients for both S.I. and (inch-pound) based calculations.

Condition	Constant (H)	Condition	Constant (H)
Low	56 (100)	High	42 (75)
Low, with reflection	72 (130)	High, with reflection	56 (100)

1, with an ASHRAE Handbook of Fundamentals, Table 1A cooling season dry bulb air temperature (T_A) of 32°C (90°F), a solar absorption value (A_B) of 0.85, and a high heat capacity (H) value of 42 (75).

substituting:

$$T_S = 32 + 0.85(42) = 68^\circ\text{C} \quad (2)$$

and

$$T_S = 90 + 0.85(75) = 154^\circ\text{F} \quad (3)$$

7.2.3.4 Eq 1 is for easterly, westerly, and southerly facing walls that receive direct solar radiation. Even some northerly facing walls receive some direct solar radiation during the summer, either in the morning or late in the afternoon. During the day, when there is no direct solar radiation on a northerly facing wall, there is an indirect solar warming effect caused by diffuse radiation reflected onto the wall from particles suspended in the atmosphere. The increase to the hottest summer air temperature due to this effect is relatively small, probably in the range of 6 to 17°C (10 to 30°F), depending on locale, orientation, wall materials, and degree of insulation. In most cases, a sealant joint width for a building is established on the basis of the wall with greatest solar exposure, with that determined joint width repeated for all the building walls. Hence, it is usually not necessary to calculate a solar radiation component for a northerly facing wall.

7.2.3.5 Table 4 lists some values for the solar absorption coefficient (A) to use in Eq 1 (19-21). Reference (22) can be used in lieu of the values in Table 4 and Eq 1 to determine various glass product surface temperatures. The coefficients of solar absorption may need to be modified based on past experience and an evaluation and understanding of the wall construction. Judgement and experience should be used by the design professional when evaluating the calculation result for T_S .

7.2.4 *Installation*—The installation temperature for a sealant joint opening in a material or system, if it can be reliably established and implemented during construction, can be used in the calculations for temperature difference and thermal movement. A word of caution: if construction schedule changes or unusual weather conditions occur, delaying a planned joint opening installation time, then the installation temperatures used for calculation may no longer be appropriate, and as a result, the joint opening or sealant dimensions may not be sufficient. Generally, installation temperatures can be established for both a winter lowest expected installation temperature (T_{IW}) and a summer maximum expected installation temperature (T_{IS}).

7.2.4.1 For example, for a brick masonry wall that will be constructed in the Detroit, Michigan area, it could be deter-

mined that no wall construction will occur below an air (and therefore a surface) temperature of T_{IW} of 4°C (40°F) during the winter or above a T_{IS} of 35°C (95°F) during the summer.

7.3 Temperature Difference:

7.3.1 *General*—Material or system temperature differences need to be established to permit calculation of material or system linear thermal movement. The temperature difference used for calculation can be the maximum that would be expected (ΔT_M) or a different value based on using expected installation temperatures of T_{IS} and T_{IW} . These values are used with the expected minimum temperature T_W and the expected maximum temperature T_S to establish installation temperature differences of ΔT_S and ΔT_W . The example of a face brick wall in 7.2.2.1, 7.2.3.3, and 7.2.4.1 is continued. The expected dimensional changes due to thermal movement for a brick masonry wall can be determined using the following equations.

7.3.2 *Maximum Temperature Difference*—The maximum expected temperature difference (ΔT_M) is simply the difference between the expected temperature extremes and is found using Eq 4.

$$\Delta T_M = T_S - T_W \quad (4)$$

substituting the values previously determined in 7.2.2.1 for T_W and 7.2.3.3 for T_S :

$$\Delta T_M = 68 - (-18) = 86^\circ\text{C} \quad (5)$$

and

$$\Delta T_M = 154 - 0 = 154^\circ\text{F} \quad (6)$$

7.3.3 *Installation Temperature Difference*—The ΔT_M value determined in 7.3.2 should be used if the maximum summer (T_{IS}) and minimum winter (T_{IW}) installation temperatures are not known or can not be achieved. However, if values for T_{IS} and T_{IW} are known and can be reliably attained during construction, then the expected summer installation temperature difference (ΔT_S) using T_{IS} , and the expected winter installation temperature difference (ΔT_W), using T_{IW} , are found using Eq 7 and Eq 8 respectively. Continuing the example of a brick masonry wall and substituting the temperature values determined in 7.2.2.1 for T_W , 7.2.3.3 for T_S , and 7.2.4.1 for T_{IW} and T_{IS} , the expected temperature differences are as follows.

$$\Delta T_S = T_{IS} - T_W \quad (7)$$

$$\Delta T_W = T_S - T_{IW} \quad (8)$$

summer installation temperature difference using Eq 7:

$$\Delta T_S = 35 - (-18) = 53^\circ\text{C} \quad (9)$$

and

$$\Delta T_S = 95 - 0 = 95^\circ\text{F} \quad (10)$$

winter installation temperature difference using Eq 8:

$$\Delta T_W = 68 - 4 = 64^\circ\text{C} \quad (11)$$

and

$$\Delta T_W = 154 - 40 = 114^\circ\text{F} \quad (12)$$

7.3.3.1 The above analysis for summer installation, winter installation, and maximum temperature differences is expressed graphically by Fig. 6. The analysis indicates that if installation temperatures can be used then, for this example, the

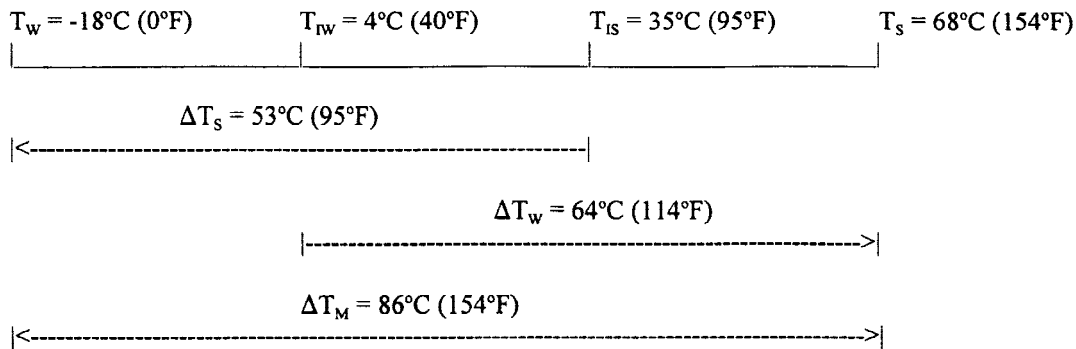

FIG. 6 Expected Thermal Movements

largest of the two installation temperature differences (ΔT_W) would be used for sealant joint design when it is expected that the sealant joint opening will be installed in the range between T_{IW} and T_{IS} . If the sealant joint opening will be installed outside of that range then ΔT_M should be used.

7.3.4 Thermal Improvement—Metal framing for curtain wall and widow systems can be of a thermally improved construction, sometimes referred to as “thermally broken.” Typically, these systems will limit the exterior exposure of the metal framing with most, and sometimes all, of the framing being in the interior conditioned space of a building. Limited available information indicates that thermally improved framing systems will experience less movement than that calculated for non-thermally improved systems. Very limited testing of three four-side structural sealant glazed curtain wall systems, as described in Reference (2), indicates that for summer conditions, the aluminum framing surface temperatures can generally be about 70 percent of the calculated summer exterior wall surface temperature, and for winter conditions, about 75 percent of the winter time interior air temperature. If data is unavailable for a thermally improved system, then the temperatures calculated for a non-thermally improved system can be used, which will result in a conservative sealant joint design. Additionally, computer programs are commercially available that model mullion shapes to determine their thermal performance. These programs may be of benefit to more accurately estimate thermally improved mullion temperature extremes. Lastly, a testing program could be instituted to determine thermal performance.

7.4 Thermal Movement:

7.4.1 A change in linear dimension (ΔL_X) of a material or assembly of materials is the product of its unrestrained length (L) multiplied by its coefficient of linear thermal movement (α_X) and its expected change in temperature (ΔT_X) using Eq 13.

$$\Delta L_X = (L)(\Delta T_X)(\alpha_X) \quad (13)$$

7.4.2 For example, a face brick wall has a length (L) of 7.32 m (24 ft), experiences a change in temperature (ΔT_W) of 64°C (114°F) as determined by Eq 8 in 7.3.3, and has a coefficient of linear thermal movement (α_B) of 0.0000065 (0.0000036), as determined from Table 2. When these values are substituted into Eq 13, the following expected thermal movement (ΔL_B) is determined.

substituting:

$$\Delta L_B = (7.32)(1000)(64)(0.0000065) = 3.0451 \text{ mm} \quad (14)$$

and

$$\Delta L_B = (24)(12)(114)(0.0000036) = 0.1182 \text{ in} \quad (15)$$

7.4.3 In the above and other calculations that follow, the value of 1000 for S.I. and 12 for inch-pound units is a factor to convert meters to millimeters and feet to inches respectively. Additionally, movement and other calculations indicate the result to 4 decimal places. This is not meant to imply a high degree of accuracy but to make conversion to decimal values easier since typically available conversion tables are shown to 4 decimal places.

7.5 Moisture Growth:

7.5.1 General—When irreversible moisture growth is included in a joint design it can be treated as a movement or as a construction tolerance. When treated as a movement it is added to the other movement(s), usually thermal, that a joint will experience. If treated as a tolerance, its value would simply be added to the width determined for the movement(s) as indicated by the examples in 7.6. However, if treated as a tolerance, the joint designer should be aware that if the joint opening is subsequently built to its least dimension (the design width less its negative construction tolerance) there may not be sufficient movement capacity remaining in the sealant width, after the moisture movement has occurred, to accommodate the anticipated other movement(s). This condition occurs only when the joint opening is built to its least allowable dimension. If it is built to its design width or its maximum allowable dimension (the design width plus its positive construction tolerance) then there may be sufficient remaining movement capacity in the sealant width for the expected movements after the irreversible movement has occurred. Presently, although a mathematical calculation indicates that irreversible moisture growth should be treated as a movement, to preclude a potential lack of other movement capability at the smallest joint width, joints have been designed where the irreversible growth has been treated as a tolerance.

7.5.1.1 The effect of a material’s moisture growth is determined as follows. The reversible moisture content coefficient (R) or the irreversible moisture growth coefficient (I) is used along with a material’s unrestrained length (L) to calculate a change in dimension (ΔL_R or ΔL_I), using Eq 16 and Eq 17 respectively.

$$\Delta L_R = \left[\frac{R}{100} \right] (L) \quad (16)$$

$$\Delta L_I = \left[\frac{I}{100} \right] (L) \quad (17)$$

7.5.2 Irreversible Moisture Growth: For example, a range of values is indicated in Table 3 for face brick dimensional change due to irreversible moisture growth (I) of face brick. If specific data for a particular brick is unavailable, the values toward the high end of the range could be used. For this example, a value of 0.03 percent recommended by ACI 530.1-88/ASCE 6-88 and BIA Technical Note 18 Revised will be used. Some of the dimensional change due to irreversible moisture growth of brick will occur before the joint opening is built; however, determining a partial effect may not be possible and the full effect should be used for joint width calculation. With a sealant joint spacing (L) of 7.32 m (24 ft) and substituting a value of 0.03 for I into Eq 17 results in the following values for irreversible growth (ΔL_I) of the face brick.

substituting:

$$\Delta L_I = \left[\frac{0.03}{100} \right] (7.32)(1000) = 2.1960 \text{ mm} \quad (18)$$

and:

$$\Delta L_I = \left[\frac{0.03}{100} \right] (24)(12) = 0.0864 \text{ in} \quad (19)$$

7.5.3 Reversible Moisture Growth: Calculation for this effect is performed similar to as described in 7.5.2, however by using Eq 16.

7.6 Sealant Joint Width Required to Accommodate Movements:

7.6.1 General—The following calculation examples for movement are based on materials or systems that are unrestrained. Most materials or systems are not, in fact, unrestrained. Restraint can be caused by, for example, frictional forces and lateral ties and anchors. Restraint can decrease the expected movement determined by calculation. Therefore, a degree of conservatism may be present for a particular movement calculation based on the extent of any restraint present for that material or system. Where appropriate, the design professional may choose to modify the calculation result to accommodate the effect of any restraint that can be reliably estimated. The degree of modification is a judgement call, based on experience and a joint design's particular circumstances.

7.6.2 Extension and Compression Movement—For a sealant joint experiencing only extension and compression movement, its width is established using Eq 20. The equation can accommodate more than one movement due to various effects. For example, a joint in a brick masonry wall will experience thermally induced movement (See 7.4.2) and irreversible moisture growth that can be treated as a movement (See 7.5.2). The joint width required to accommodate the expected movements (W_M), exclusive of any required tolerances, is equal to the sum of the expected movements (ΔL_X) divided by the movement capacity (S) of the sealant expressed as a decimal (e.g. ± 50 percent movement capacity expressed as 0.50).

$$W_M = \frac{\Delta L_{X1} + \Delta L_{X2} + \Delta L_{XN}}{S} \quad (20)$$

7.6.2.1 Continuing the face brick wall example, and using thermal movement (ΔL_B) of 3.0451 mm (0.1182 in), determined in 7.4.2, moisture growth (ΔL_I) of 2.1960 mm (0.0864 in) determined in 7.5.2 and treated as a movement, and a sealant movement capacity (S) of 0.50, the expected joint width (W_M) to satisfy dimensional changes due to thermal and moisture irreversible movements is found using Eq 20.

Substituting:

$$W_M = \frac{3.0451 + 2.1960}{0.50} = 10.4822 \text{ mm} \quad (21)$$

and

$$W_M = \frac{0.1182 + 0.0864}{0.50} = 0.4092 \text{ in} \quad (22)$$

7.6.2.2 For this example, the sealant is used at its manufacturer's rated movement capacity, since those performance factors that affect joint design have been adequately identified and accounted for, and the sealant will be installed in new construction with proper joint cleaning, preparation, and workmanship (See 6.9). Although the width required for movement has been established, the joint design is incomplete since applicable construction tolerances (See 7.7) must be included in the sealant joint width design (See 7.8).

7.6.3 Longitudinal or Transverse Shear Movement—A dimensional change that produces a diagonal extension of a sealant produces a change in a joint opening width (See Fig. 2.). To not exceed the movement capacity (S) of the sealant, the diagonal length of the sealant after longitudinal or transverse extension (E_X) must not be greater than the joint width at rest (W_R) plus the movement capacity of the sealant, expressed as a decimal, multiplied by that width (See 6.8).

7.6.3.1 A simple trigonometric equation, based on the Pythagorean Theorem, can be used to determine the expected joint width (See Fig. 7). If W_R represents the sealant joint width prior to extension, ΔL_X the sealant extension caused by longitudinal or transverse movement, and $[W_R + (S)W_R]$ the diagonal sealant length after longitudinal or transverse movement, the equation to determine the expected joint width W_R is found using Eq 23.

$$W_R^2 + \Delta L_X^2 = [W_R + (S)W_R]^2 \quad (23)$$

solving for W_R :

$$W_R = \sqrt{\frac{\Delta L_X^2}{(1 + S)^2 - 1}} \quad (24)$$

7.6.3.2 The following is an example of using Eq 23 to determine the sealant joint width necessary to accommodate longitudinal or transverse movement. It should be realized that for Eq 23 and similar equations that follow, the determined value for W_R is equivalent to determining W_M , the sealant joint width required to accommodate movement. Continuing the face brick wall example, and using the sum of thermal movement (ΔL_B) of 3.0451 mm (0.1182 in) determined in 7.4.2 and irreversible growth (ΔL_I) of 2.1960 mm (0.0864 in) determined in 7.5.2 as the value for longitudinal extension (ΔL_X) and a sealant with a 25 percent movement capacity, expressed as 0.25, the minimum width (W_R) needed to accommodate the anticipated movement is determined by substituting in Eq 23.

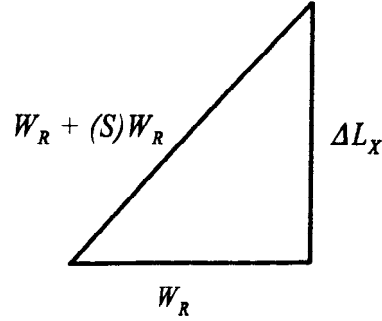

FIG. 7 Sealant Joint Diagonal Extension Movement

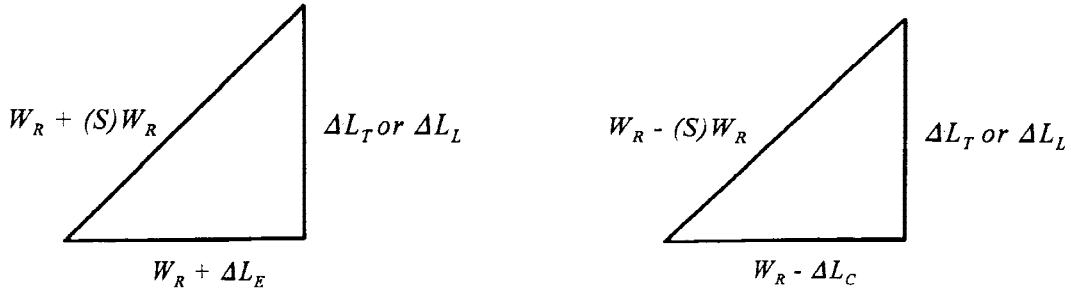

FIG. 8 Sealant Joint Movement Combination

Extension Movements

Compression and Extension Movements

Substituting:

$$W_R = \sqrt{\frac{(3.0451 + 2.1960)^2}{(1 + 0.25)^2 - 1}} = 6.9881 \text{ mm} \quad (25)$$

and

$$W_R = \sqrt{\frac{(0.1182 + 0.0864)^2}{(1 + 0.25)^2 - 1}} = 0.2728 \text{ in} \quad (26)$$

7.6.4 *Movement Combinations*—It is not uncommon for a sealant joint to be the separation between different materials or systems on a building wall or to be a transition in plane of walls that are crosswise to each other. As a result, a sealant can simultaneously experience extension and compression movement in one direction and longitudinal or transverse movement in another (See Fig. 3 and Fig. 4). If the combined movements are not occurring relatively simultaneously, these equations may not be appropriate and the movements should be evaluated separately for their effects on the sealant joint. The combined movements can again be represented by a simple trigonometric equation based on the Pythagorean Theorem (See Fig. 8). The effects of these simultaneous movements can be combined using Eq 27 and Eq 28 for combined extension movements and Eq 29 and Eq 30 for combined compression and longitudinal or transverse extension movement to establish the required joint width.

Extension combined with transverse extension:

$$[W_R + S(W_R)]^2 = [W_R + \Delta L_E]^2 + [\Delta L_T]^2 \quad (27)$$

Extension combined with longitudinal extension:

$$[W_R + S(W_R)]^2 = [W_R + \Delta L_E]^2 + [\Delta L_L]^2 \quad (28)$$

Compression combined with transverse extension:

$$[W_R - S(W_R)]^2 = [W_R - \Delta L_C]^2 + [\Delta L_T]^2 \quad (29)$$

Compression combined with longitudinal extension:

$$[W_R - S(W_R)]^2 = [W_R - \Delta L_C]^2 + [\Delta L_L]^2 \quad (30)$$

solving for W_R in Eq 27 and Eq 28 respectively:

$$W_R = \frac{-(-2\Delta L_E) + \sqrt{(-2\Delta L_E)^2 - 4(S^2 + 2S)[-(\Delta L_E^2 + \Delta L_T^2)]}}{2(S^2 + 2S)} \quad (31)$$

and

$$W_R = \frac{-(-2\Delta L_E) + \sqrt{(-2\Delta L_E)^2 - 4(S^2 + 2S)[-(\Delta L_E^2 + \Delta L_L^2)]}}{2(S^2 + 2S)} \quad (32)$$

solving for W_R in Eq 29 and Eq 30 respectively:

$$W_R = \frac{-(2\Delta L_C) - \sqrt{(2\Delta L_C)^2 - 4(S^2 - 2S)[-(\Delta L_C^2 + \Delta L_T^2)]}}{2(S^2 - 2S)} \quad (33)$$

and

$$W_R = \frac{-(2\Delta L_C) - \sqrt{(2\Delta L_C)^2 - 4(S^2 - 2S)[-(\Delta L_C^2 + \Delta L_L^2)]}}{2(S^2 - 2S)} \quad (34)$$

7.6.4.1 *Extension with Transverse or Longitudinal Extension Movement*—The following is an example of using Eq 27

to determine the sealant joint width required to accommodate both extension and transverse extension movements. For extension combined with longitudinal extension movement Eq 28 is used similar to this example. For this example, two walls crosswise to each other, are separated by a sealant joint. The sealant experiences movement in extension from one wall and transverse extension from the other. For this example, previous calculations have determined the extension movement ΔL_E for

$$W_R = \frac{-[-2(5.3696)] + \sqrt{[-2(5.3696)]^2 - 4[(0.50)^2 + 2(0.50)][-(5.3696)^2 + (4.2520)^2]}}{2[(0.50)^2 + 2(0.50)]} = 11.7778 \text{ mm} \quad (35)$$

and

$$W_R = \frac{-[-2(0.2114)] + \sqrt{[-2(0.2114)]^2 - 4[(0.50)^2 + 2(0.50)][-(0.2114)^2 + (0.1674)^2]}}{2[(0.50)^2 + 2(0.50)]} = 0.4637 \text{ in} \quad (36)$$

7.6.4.2 Compression with Transverse or Longitudinal Extension Movement—The following is an example of using Eq 29 to determine the sealant joint width required to accommodate both compression and transverse extension movements. For compression combined with longitudinal extension movement Eq 30 is used similar to this example. For this example, two walls crosswise to each other are separated by a sealant joint. The sealant experiences movement in compression from one wall and transverse extension from the other. For this

example, previous calculations have determined the extension movement ΔL_T for the second wall is 4.2520 mm (0.1674 in). A sealant with a 50 percent movement capacity expressed as 0.50 will be used. The minimum width (W_R) to accommodate the anticipated movement is determined by substituting in Eq 31.

Substituting:

example, previous calculations have determined the compression movement ΔL_C for the first wall is 6.2484 mm (0.2460 in) and the transverse extension movement ΔL_T for the second wall is 3.5230 mm (0.1387 in). A sealant with a 25 percent movement capacity expressed as 0.25 will be used. The minimum width (W_R) to accommodate the anticipated movement is determined by substituting in Eq 33.

Substituting:

$$W_R = \frac{-[2(6.2484)] - \sqrt{[2(6.2484)]^2 - 4[(0.25)^2 - 2(0.25)][-(6.2484)^2 + (3.5230)^2]}}{2[(0.25)^2 - 2(0.25)]} = 23.5755 \text{ mm} \quad (37)$$

and

$$W_R = \frac{-[2(0.2460)] - \sqrt{[2(0.2460)]^2 - 4[(0.25)^2 - 2(0.25)][-(0.2460)^2 + (0.1387)^2]}}{2[(0.25)^2 - 2(0.25)]} = 0.9282 \text{ in} \quad (38)$$

7.7 Tolerances:

7.7.1 General—It can not be stressed enough that adequate tolerances for the manufacturing, fabricating, and erection of materials and systems have to be established and then included in the design of sealant joints (See 5.15). Tolerances that are inadequately or not considered during design have proven by costly experience to be a major causative factor in the failure of sealant joints. For a particular sealant joint design, the construction method and type of tolerances will have to be considered. For example, when constructing a joint opening in a construction-site erected brick veneer wall a tolerance of ± 3 mm ($\pm 1/8$ in) could be expected for the width of the opening. The -3 mm ($-1/8$ in) tolerance causes a narrowing of the joint opening. When erecting a precast concrete panel system with a

casting tolerance of $+3$, -6 mm ($+1/8$, $-1/4$ in) a narrowing of the joint opening between panels of 3 mm ($1/8$ in) could occur. However, the erection tolerances for the precast panel, ± 6 mm ($\pm 1/4$ in), also have to be considered with the casting tolerance to determine the tolerance to be used for the joint opening between panels. For a sealant joint opening it is the net negative and positive tolerance effects that are used in the width calculation.

7.7.2 Negative Tolerance—A negative tolerance is one that has a tendency to cause a joint opening to become smaller. This has serious technical concerns in that, if not considered, a joint becomes too small to accommodate anticipated movements within the movement capacity of the sealant. The sealant in

these circumstances can become stressed beyond its manufacturer's rating and subject to failure.

7.7.3 Positive Tolerance—A positive tolerance is one that has a tendency to cause a joint opening to become larger. A larger joint opening rarely causes a technical concern unless a joint becomes too large to permit adequate sealant installation. The primary consideration in this circumstance is aesthetic, with the joint width becoming larger and perhaps more prominent than anticipated. All else being equal, a wider joint is better because potential durability is greater, due to a lower state of stress in the sealant when experiencing movement.

7.8 Sealant Joint Width:

7.8.1 General—The following illustrates how to determine the final designed joint width (W) for three commonly encountered sealant joint types. A joint designer should be aware that the calculation examples are for a joint that is sealed when the opening is at the calculated width. If the joint is sealed at a time when the opening is at a different width, a deficiently sized joint could be created that may be prone to failure, depending on the expected movement from the sealed width and the joint width when sealed. For all sealant joint designs, the effect of a negative tolerance(s) is evaluated and then added to the dimension obtained for the joint width (W_M) that was determined for the anticipated movement(s). Positive and negative tolerances are usually indicated as a ± value listed after the value established for the sealant joint width. The theoretically determined joint width must also be evaluated considering normal construction procedures which could require a different width and/or tolerance requirement. When rounding off fractional joint width values it is prudent to round up. The designed joint width dimension should be a value suitable to the application. For example, indicating a joint width as 21 ± 5 mm (13/16 ± 3/16 in) for joints between precast concrete panels does not recognize that normal precast concrete construction procedures would be incapable of achieving 2 mm (1/16 in) increments of dimension. It would be more realistic to indicate the joint width as 22 ± 6 mm (7/8 ± 1/4 in) by rounding up the calculation to dimensions compatible with the construction materials and methods.

7.8.2 Butt Sealant Joint—A typically encountered butt sealant joint is a vertical expansion joint in a masonry wall (See

Fig. 9.). After the width (W_M) has been determined based on the expected movement(s) the negative construction tolerance(s) (C_X) must be added to that value to arrive at the designed width for the joint opening. For example, using the width required for movement (W_M) determined in 7.6.2.1, which includes both thermal and moisture movement, and a construction tolerance (C_B) for the constructed width of the joint opening of ± 3 mm (± 1/8 in), the final designed joint width (W) of a butt sealant joint is determined using Eq 39.

$$W = W_M + C_X \tag{39}$$

substituting:

$$W = 10.4822 + 3.0000 = 13.4822 \text{ mm} \tag{40}$$

and

$$W = 0.4092 + 0.1250 + 0.5342 \text{ in} \tag{41}$$

and rounding up:

$$W = 14 \pm 3 \text{ mm and } \left(\frac{9}{16} \pm \frac{1}{8} \text{ in} \right) \tag{42}$$

7.8.3 Fillet Sealant Joint—In addition to new construction, this type of joint (See Fig. 10.) is often used for remedial sealing work where situations are encountered such as a faulty installation, a sealant joint design failure, sealant replacement due to weathering, or where the existing joint is too narrow to permit installation of the preferred butt type joint (4). The size of the sealant joint is based on the length of the contact side of a triangular or other appropriate shape sealant backing (B). The sealant backing required length is determined by dividing the expected movement (ΔL_X) by the movement capacity (S) of the sealant, as illustrated by Eq 43.

$$B = \frac{\Delta L_X}{S} \tag{43}$$

7.8.3.1 For example, a joint design for a remedial sealing application is necessary for an aluminum framed window in a brick masonry wall, where the space between the frame and brick is too narrow for a butt type joint and, due to the previously installed and failed fillet sealant, optimum surface adhesion can not be achieved due to the difficulty of adequately cleaning the original sealant from the sealant adhesion surfaces. To have less stress at the sealant adhesion surface for this

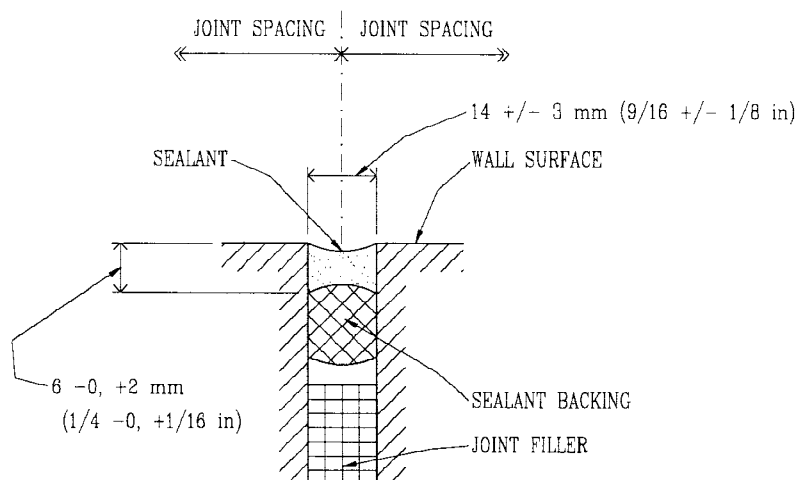

FIG. 9 Cross-Section of a Typical Butt Sealant Joint

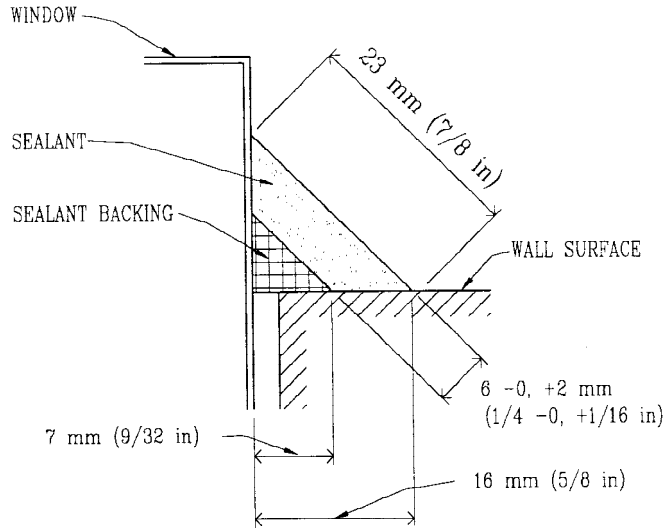

FIG. 10 Cross-Section of a Typical Fillet Sealant Joint

condition a judgement has been made to use a ± 50 percent movement capacity sealant at a ± 35 percent rating. The expected movements to be accommodated between the window frame and the surrounding masonry wall should be calculated. For this example, it is assumed that the expected movement (ΔL_x) will be 2.4500 mm (0.0984 in), with the required joint width determined using Eq 43 as follows:

$$B = \frac{2.4500}{0.35} = 7.0000 \text{ mm} \quad (44)$$

and

$$B = \frac{0.0984}{0.35} = 0.2811 \text{ in} \quad (45)$$

and rounding off:

$$B = 7 \text{ mm} \left(\frac{9}{32} \text{ in} \right) \quad (46)$$

7.8.4 Bridge Sealant Joint—This type of sealant joint, sometimes referred to as a “band aid” sealant joint, (See Fig. 11.) is often used in remedial sealant work to seal failed sealant joints when a more conventional butt type joint cannot be used (5). For example, a butt joint may not be suitable for an application due to an undersized opening that is not economi-

cally or technically possible to enlarge for a remedial sealant application. The width of the sealant joint is based on the width of the necessary bond breaker tape or sealant backing (B). This width is determined by dividing the expected thermal movement (ΔL_x) by the movement capacity (S) of the sealant, as illustrated by Eq 43.

7.8.4.1 For example, a wall of precast concrete panels was erected with joint openings that were too small to accommodate the expected movement and the sealant failed. The final designed bridge joint width (W) can be established based on determining the precast concrete panel expected thermal movement using Eq 1, Eq 4, and Eq 13. For this example, an assumed value for (ΔL_p) of 5.4864 mm (0.2160 in) will be used. The precast concrete panel adhesion surfaces for the remedial sealant work can be cleaned of old sealant and other materials and a judgement is made to use a ± 50 percent movement capacity sealant at a ± 40 percent rating. The joint width is established using Eq 43 to determine the required bond breaker tape or sealant backing dimension.

substituting:

$$B = \frac{5.4864}{0.40} = 13.7160 \text{ mm} \quad (47)$$

and

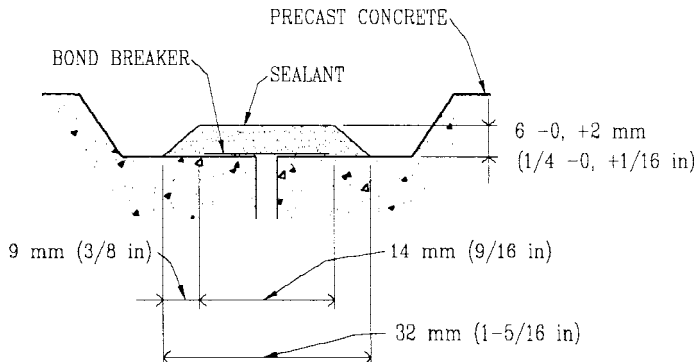

FIG. 11 Cross-section of a Typical Liquid-Applied Bridge Sealant Joint

$$B = \frac{0.2160}{0.40} = 0.5400 \text{ in} \quad (48)$$

and rounding off:

$$B = 14 \text{ mm} \left(\frac{9}{16} \text{ in} \right) \quad (49)$$

7.8.4.2 Traditionally, a liquid-applied sealant has been used for a bridge type sealant joint. Application of the liquid-applied sealant has been problematic in attaining adequate sealant thickness (depth) and an aesthetically pleasing application. Precured sealant extrusions (See Fig. 5) have become the sealant product best suited for bridge joint applications due to consistent thickness and ease of application.

7.9 Sealant Joint Depth:

7.9.1 *General*—For joints that experience movement, if the ratio of sealant width to depth (the shape factor) is not properly established, the ability of the sealant to accommodate movement can be seriously compromised. Within the following guidelines, a typically recommended shape factor for a butt sealant joint is 2:1.

7.9.2 *Butt Sealant Joint*—The depth of a butt type sealant joint at its adhesion surface is established as follows (See Fig. 9.). In general, sealant adhesion depth at a substrate surface should be no less than 6 mm (¼ in) for joint widths from 6 mm (¼ in) to 12 mm (½ in). From 12 mm (½ in) to 18 mm (¾ in) in width the adhesion depth should be ½ of the joint width. For joint widths in excess of 18 mm (¾ in) to 50 mm (2 in) a maximum depth of 9 mm (¾ in) should be considered. For joint widths in excess of 50 mm (2 in) the sealant manufacturer should be consulted. After the sealant surface is tooled, the minimum sealant depth at the midpoint of the joint opening under no circumstances should be less than 3 mm (⅛ in). However, it should be recognized that the minimum required sealant thickness at the midpoint of the joint opening may have to be greater than 3 mm (⅛ in). The minimum required

thickness will vary by sealant manufacturer and sealant type and should be verified with the manufacturer.

7.9.3 *Fillet, Bridge, and Other Sealant Joints*—In general, a sealant adhesion dimension at a substrate surface should be no less than 6 mm (¼ in) (See Figs. 9 and 10). Circumstances such as a varying or rough adhesion surface or the inability to gain installation access may require a greater adhesion surface to achieve the anticipated design performance for the sealant joint. The sealant depth over the sealant backing or bond breaker tape should be 6 mm (¼ in). However, depending on sealant type and the quality of installation practices, a minimum thickness of 3 mm (⅛ in) has been successfully achieved. The minimum required thickness should be verified with the sealant manufacturer.

7.9.4 *Precured Sealant Extrusion*—The depth or thickness of a precured sealant extrusion is determined by the manufacturer (See Fig. 5.). The adhesion surface for a liquid-applied sealant/adhesive should be, in general, for extrusions up to 50 mm (2 in) wide a minimum of 9 mm (¾ in) and when over 50 mm (2 in) wide a minimum of 13 mm (½ in).

7.9.5 *Sealant Joints for Pedestrian and Vehicular Traffic*: The depth of sealant required for these joints may vary from that for non-horizontally oriented surfaces. Choice of sealant type, sealant backing, and joint filler, and level of expected traffic can all have an effect on the sealant depth required for an application. The minimum required sealant thickness as well as other joint design characteristics should be verified with the sealant manufacturer.

8. Keywords

8.1 bridge joint; butt joint; construction tolerance; expansion joint; fillet joint; moisture movement; performance factor; sealant; sealant backing; sealant joint design; thermal movement

APPENDIX

X1. GENERAL INDEX TO TOPICS AND HEADINGS AS LISTED IN THE GUIDE

X1.1 Index

1. Scope

2. Referenced Documents

- 2.1 ASTM Standards
- 2.2 American Concrete Institute (ACI) and American Society of Civil Engineers (ASCE)
- 2.3 Prestressed Concrete Institute (PCI)
- 2.4 American Society of Heating, Refrigerating and Air-Conditioning Engineers, Inc. (ASHRAE)
- 2.5 Brick Institute of America (BIA)
- 2.6 Institute of Electrical and Electronics Engineers, Inc. (IEEE) and ASTM

3. Terminology

- 3.1 Definitions
- 3.2 Definitions of Terms Specific to This Standard
 - 3.2.1 Coefficient of linear thermal movement
 - 3.2.2 Coefficient of solar absorption
 - 3.2.3 Durability
 - 3.2.4 Durability limit
 - 3.2.5 Heat capacity constant
 - 3.2.6 Premature deterioration
 - 3.2.7 Service life
- 3.3 Symbols

4. Significance and Use

5. Performance Factors

- 5.1 General
- 5.2 Material and System Anchorage
- 5.3 Thermal Movement
- 5.4 Thermal Movement Environmental Influences
- 5.5 Coefficient of Linear Thermal movement
- 5.6 Moisture Induced Growth
- 5.7 Live Load Movement
- 5.8 Dead Load Movement
- 5.9 Wind Load Movement
- 5.10 Seismic Movement
- 5.11 Movement During Sealant Curing
- 5.12 Elastic Frame Shortening
- 5.13 Creep
- 5.14 Shrinkage
- 5.15 Construction Tolerances
 - 5.15.1 Material
 - 5.15.2 Fabrication
 - 5.15.3 Erection
 - 5.15.4 Accumulated Tolerances

6. Sealant Joint Movement

- 6.1 General
- 6.2 Compression
- 6.3 Extension
- 6.4 Extension and Compression
- 6.5 Longitudinal Extension
- 6.6 Transverse Extension
- 6.7 Movement Combinations
- 6.8 Sealant Stresses in Extension and Shear
- 6.9 Sealant Movement Capability and Rating
 - 6.9.1 Liquid-Applied Sealant
 - 6.9.2 Precured Sealant Extrusion
- 7. Equations**
 - 7.1 General
 - 7.2 Surface Temperature
 - 7.2.1 General
 - 7.2.2 Winter
 - 7.2.3 Summer
 - 7.2.4 Installation
 - 7.3 Temperature Difference
 - 7.3.1 General
 - 7.3.2 Maximum Temperature Difference
 - 7.3.3 Installation Temperature Difference
 - 7.3.4 Thermal Improvement
 - 7.4 Thermal Movement
 - 7.5 Moisture Growth
 - 7.5.1 General
 - 7.5.2 Irreversible Moisture Growth

- 7.5.3 Reversible Moisture Growth
- 7.6 Sealant Joint Width Required to Accommodate Movements
 - 7.6.1 General
 - 7.6.2 Extension and Compression Movement
 - 7.6.3 Longitudinal or Transverse Shear Movement
 - 7.6.4 Movement Combinations
 - 7.6.4.1 Extension with Transverse or Longitudinal Extension Movement
 - 7.6.4.2 Compression with Transverse or Longitudinal Extension Movement
- 7.7 Tolerances
 - 7.7.1 General
 - 7.7.2 Negative Tolerance
 - 7.7.3 Positive Tolerance
- 7.8 Sealant Joint Width
 - 7.8.1 General
 - 7.8.2 Butt Sealant Joint
 - 7.8.3 Fillet Sealant Joint
 - 7.8.4 Bridge Sealant Joint
- 7.9 Sealant Joint Depth
 - 7.9.1 General
 - 7.9.2 Butt Sealant Joint
 - 7.9.3 Fillet, Bridge, and Other Sealant Joints
 - 7.9.4 Precured Sealant Extrusion
 - 7.9.5 Sealant Joints for Pedestrian and Vehicular Traffic

8. Keywords References

REFERENCES

- (1) Klosowski, J.M., *Sealants in Construction*, Marcel Dekker, Inc., New York, 1989.
- (2) O'Connor, T.F., "Recent Developments in the Design of Sealant Joints for Movement and Other Effects", *Building Seals, Sealants, Glazing and Waterproofing*, ASTM STP 1271, M. A. Lacasse, ed., ASTM, Philadelphia, PA, 1996, pp. 3-41.
- (3) O'Connor, T.F., and Droz, H.L. "Design Considerations for Sealants When used at Horizontal Expansion Joints in Masonry Cavity Walls", *Science and Technology of Building Seals, Sealants, Glazing, and Waterproofing - Sixth Volume*, ASTM STP 1286, J.C. Myers, Ed., ASTM, Philadelphia 1996, pp. 63-83.
- (4) Myers, J.C., "Behavior of Fillet Sealant Joints", *Building Sealants: Materials, Properties, and Performance*, ASTM STP 1069, T.F. O'Connor, ed., ASTM, Philadelphia, PA 1990, pp 108-121.
- (5) Myers, J.C., "Performance of Band-Aid Sealant Joints", *Science and Technology of Building Seals, Sealants, Glazing, and Waterproofing - Fourth Volume*, ASTM STP 1243, D. H. Nicastro, Ed., ASTM, Philadelphia 1994, pp. 90-97.
- (6) Hutchinson, A.R., Jones, T.G.B., and Atkinson, K.E. "Building Joint Movement Monitoring and Development of Laboratory Simulation Rigs", Durability of Building Sealants, State-of-the-Art Report and Proceedings of the Second International RILEM Symposium, A.T. Wolf, Ed., E & FN Spon, London, United Kingdom.
- (7) "Estimation of Thermal and Moisture Movements and Stresses: Part 1", *Building Research Establishment Digest 227*, Building Research Station, Garston, Watford UK, 1979.
- (8) "Estimation of Thermal and Moisture Movements and Stresses: Part 2", *Building Research Establishment Digest 228*, Building Research Station, Garston, Watford UK, 1979.
- (9) *Building Movements and Joints*, Portland Cement Association, Skokie, 1982.
- (10) Korista, D.S., "Exterior Facade System - Building Structure Systems - Load-Deformation Behavioral Inter-Relationships", *Exterior Claddings on High-Rise Buildings*, Proceedings of the Chicago Committee on High Rise Buildings, 1989 Fall Symposium, Chicago, IL, 1990.
- (11) Brower, J.R., "Deformation of Building Sealants Due to Movement During Cure", *Science and Technology of Building Seals, Sealants, Glazing, and Waterproofing*, ASTM STP 1168, C.J. Parise, Ed., ASTM, Philadelphia 1992, pp. 5-8.
- (12) Flackett, D.R., "Effect of Early Joint Movement on Oxime Silicone sealants and Comparison on Other One-Part Silicone Systems", *Science and Technology of Building Seals, Sealants, Glazing, and Waterproofing - Second Volume*, ASTM STP 1200, J.M. Klosowski, Ed., ASTM, Philadelphia 1992, pp. 299-310.
- (13) Lacasse, M.A., and Margeson, J.C., "Movement During Cure of Latex Building Joint Sealants", *Science and Technology of Building Seals, Sealants, Glazing, and Waterproofing - Sixth Volume*, ASTM STP 1286, J.C. Myers, Ed., ASTM, Philadelphia 1996, pp. 129-145.
- (14) Matsumoto, Y., "The Effect of Building Joint Movements on Outdoor Performance of Sealants During Their Cure", *Science and Technology of Building Seals, Sealants, Glazing, and Waterproofing*, ASTM STP 1168, C.J. Parise, Ed., ASTM, Philadelphia 1992, pp. 30-44.
- (15) Margeson, J.C., "The Effect of Movement During Cure on Sealant Strength Development", *Science and Technology of Building Seals, Sealants, Glazing, and Waterproofing*, ASTM STP 1168, C.J. Parise, Ed., ASTM, Philadelphia 1992, pp. 22-29.
- (16) Rainger, P., *Movement Control in the Fabric of Buildings*, Nichols Publishing Company, New York, 1983.
- (17) Ballast, D.K., *Handbook of Construction Tolerances*, McGraw-Hill, Inc., New York, 1994.
- (18) Shisler, F.W. and Klosowski, J.M., "Sealant Stresses in Tension and Shear", *Building Sealants: Materials, Properties, and Performance*, ASTM STP 1069, T.F. O'Connor, ed., ASTM, Philadelphia, PA, 1990, pp. 95-107.
- (19) Latta, J.K., "Dimensional Changes Due to Temperature", *Record of the DBR Building Science Seminar on Cracks, Movements and Joints in Buildings*, NRCC 15477, National Research Council of Canada, Ottawa, 1972.
- (20) Handegord G.O., and Karpati, K.K., "Joint Movement and Sealant Selection", *Canadian Building Digest 155*, National Research Council of Canada, Ottawa, 1973.
- (21) Grimm, C.T., "Thermal Strain in Brick Masonry", *Proceedings of the Second North American Masonry Conference*, The Masonry Society, 1982.

(22) *Window 4.0, A Fenestration Product Thermal Analysis Program,*
Windows and Daylighting Group, Energy and Environment Division,

Lawrence Berkeley Laboratory, Berkeley, California, 1988-1992.

ASTM International takes no position respecting the validity of any patent rights asserted in connection with any item mentioned in this standard. Users of this standard are expressly advised that determination of the validity of any such patent rights, and the risk of infringement of such rights, are entirely their own responsibility.

This standard is subject to revision at any time by the responsible technical committee and must be reviewed every five years and if not revised, either reapproved or withdrawn. Your comments are invited either for revision of this standard or for additional standards and should be addressed to ASTM International Headquarters. Your comments will receive careful consideration at a meeting of the responsible technical committee, which you may attend. If you feel that your comments have not received a fair hearing you should make your views known to the ASTM Committee on Standards, at the address shown below.

This standard is copyrighted by ASTM International, 100 Barr Harbor Drive, PO Box C700, West Conshohocken, PA 19428-2959, United States. Individual reprints (single or multiple copies) of this standard may be obtained by contacting ASTM at the above address or at 610-832-9585 (phone), 610-832-9555 (fax), or service@astm.org (e-mail); or through the ASTM website (www.astm.org).